



GRAZER GROUND MOWERS

Models

**GI652, 0052-T, G52A, G52AC,
0052T, 0052TC, 52A, 52AC,
0052TCSS, 0052CII
(52" MOWER DECKS)**

Parts List



Grazer Division, Ingersoll Equipment Company
Winneconne, WI 54986

TABLE OF CONTENTS

CHAIN DRIVE MOWERS

GI652 MOWER DECK (1982)	A4
GI652 MOWER DECK (1983)	A6
0052-T MOWER DECK (1984-1986)	A8
0052T, 0052TC, G52T, G52TC DECK PARTS (1987-1991)	A9
0052T, 0052TC, G52T, G52TC DECK DRIVE (1987-1991)	A10
52A, 52AC, 52TCSS DECK PARTS (1992 AND AFTER)	A12
52A, 52AC, 52TCSS DECK DRIVE (1992 AND AFTER)	A14

HYDRAULIC DRIVE TRACTORS

0052TCSS, 0052TCII DECK PARTS (1988-1991)	B1
0052TCSS, 0052TCII DECK DRIVE (1988-1991)	B2
0052TCSS, 0052TCII DECK PARTS (1992 AND AFTER)	B4
0052TCSS, 0052TCII DECK DRIVE (1992 AND AFTER)	B6

MISC.

DECALS	B7
GEAR BOX	B8-B10

APPLICATION CHART

52" DECKS ON CHAIN DRIVE MOWERS

DECK MODEL	YEAR USED	MOWER MODEL
GI652	1982-1983	GI652
0052-T	1984-1986	GI600, GI800
G52A, G52AC	1987-1991	GI250, GI800
0052T, 0052TC	1987-1991	GI250, GI800
52A, 52AC, 52TCSS	1992 AND AFTER	GI250, GI600, GI800CD

52" DECKS ON HYDRAULIC DRIVE MOWERS

DECK MODEL	YEAR USED	MOWER MODEL
0052TCSS, 0052TCII	1988-1991	GI800, GI890
0052TCSS, 0052TCII	1992 AND AFTER	GI890, G2090

G1652 MOWER DECK ASSEMBLY

G1652 MOWER DECK ASSEMBLY

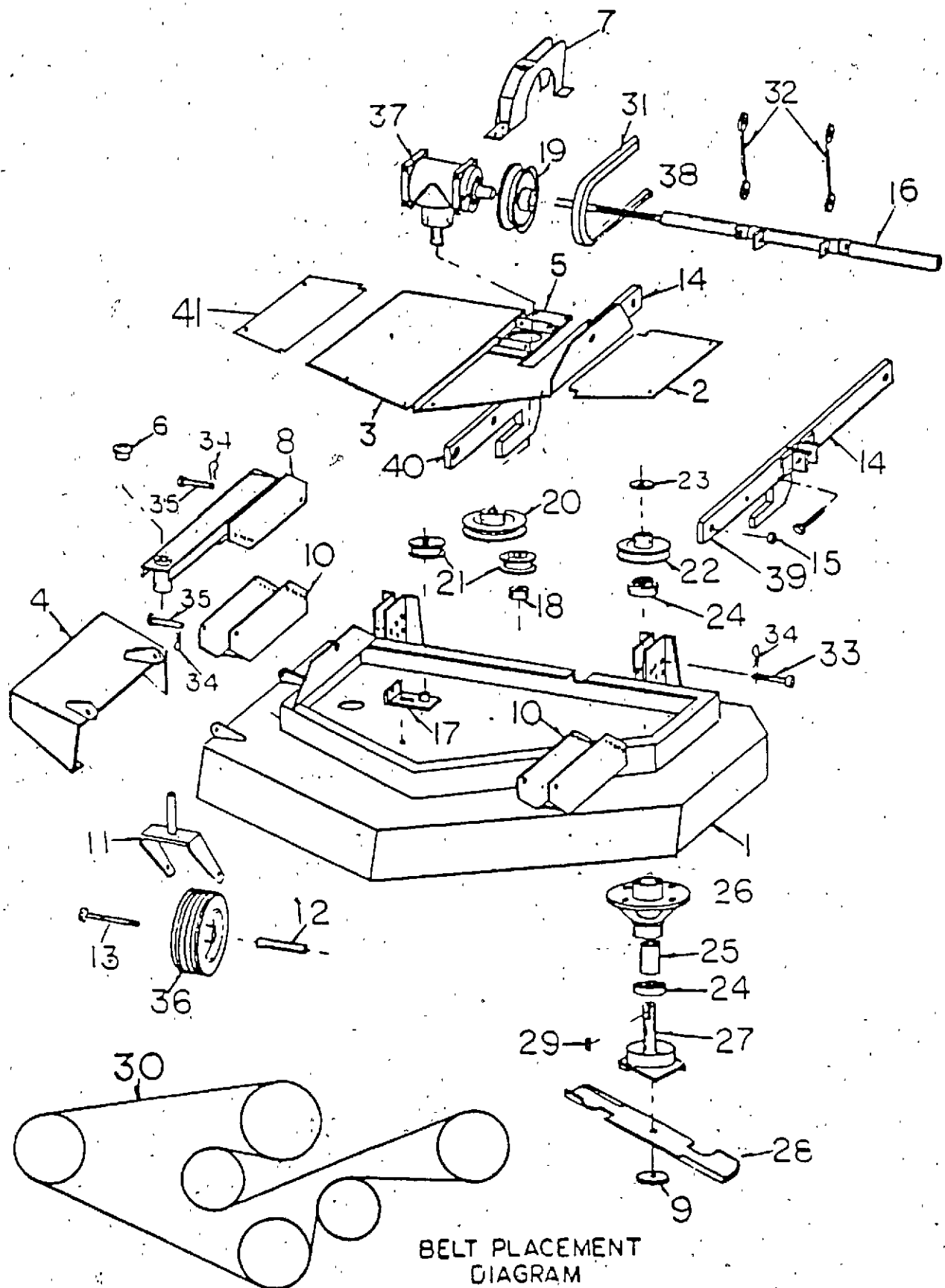

REF. NO.	PART NO.	NO. REQ'D.	DESCRIPTIONS
1.	320-0000	1	MOWER DECK
2.	320-0001	1	COVER (SMALL)
3.	320-0002	1	COVER (LARGE)
4.	320-0003	1	FOOT GUARD
5.	320-0004	1	GEAR BOX MOUNT
6.	900-3507	4	GAGE WHEEL BUSHING
7.	300-0036	1	BELT GUARD
8.	320-0005	2	GAGE WHEEL MOUNT
9.	900-5534	3	SPRING WASHER
10.	320-0006	2	BRACKET, GAGE WHEEL MOUNT
11.	320-0007	2	FORK, GAGE WHEEL
12.	320-0008	2	AXLE, GAGE WHEEL
13.	-----	2	GAGE WHEEL BOLT
14.	300-0024	2	DECK LIFT ARM BACK ADJUSTABLE
15.	300-0013	2	BUSHING, DECK LIFT ARM
16.	300-0014	1	CROSSBAR
17.	300-0012	1	BELT TIGHTENER
18.	300-0016	1	SPACER, IDLER
19.	900-2514	1	PULLEY, GEAR BOX (IN-PUT)
20.	900-2510	1	PULLEY, GEAR BOX (OUT-PUT)
21.	900-2508	2	PULLEY, IDLER
22.	900-2511	2	PULLEY, SPINDLE
23.	300-0017	3	WASHER, SPINDLE
24.	900-3505	6	BEARING SPINDLE
25.	300-0027	3	SPACER SPINDLE
26.	300-0025	3	HOUSING SPINDLE
27.	300-0026	2	SHAFT SPINDLE
28.	900-5528	3	BLADE
29.	300-0021	3	KEY SPINDLE
30.	900-3005	1	BELT, DECK
31.	900-3004	1	BELT, DRIVE
32.	900-5518	2	CABLE, DECK
33.	900-5519	2	PINS, DECK
34.	900-5520	6	HAIR PIN
35.	900-5536	4	PINS, GAGE WHEEL
36.	900-4020	2	GAGE WHEEL
37.	900-5535	1	GEAR BOX
38.	300-0022	1	CROSS BAR PIN
39.	300-0023 L.H.	1	DECK LIFT ARM FRONT ADJUSTABLE L.H.
40.	300-0023 R.H.	1	DECK LIFT ARM FRONT ADJUSTABLE R.H.
41.	320-0009	1	COVER, RIGHT HAND SIDE

GI652 MOWER DECK ASSEMBLY

1983

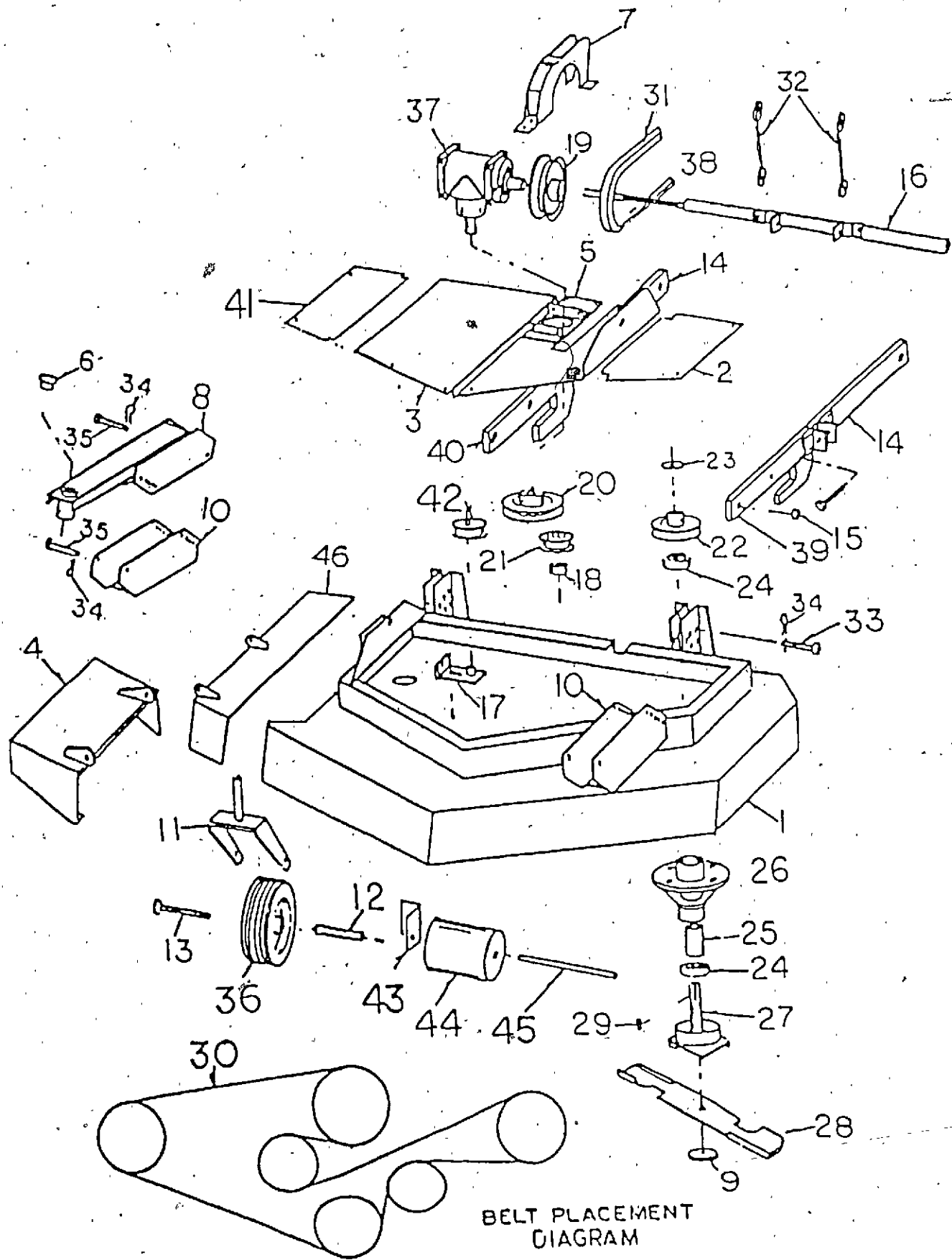

GI652 MOWER DECK ASSEMBLY

REF. NO.	PART NO.	NO. REQD.	DESCRIPTIONS
1.	320-0000	1	MOWER DECK
2.	320-0001	1	COVER (SMALL)
3.	320-0002	1	COVER (LARGE)
4.	320-0003	1	FOOT GUARD
5.	320-0004	1	GEAR BOX MOUNT
6.	900-3507	4	CAGE WHEEL BUSHING
7.	300-0036	1	BELT GUARD
8.	320-0005	2	CAGE WHEEL MOUNT
9.	900-5534	3	SPRING WASHER
10.	320-0006	2	BRACKET, CAGE WHEEL MOUNT
11.	320-0007	2	FORK, CAGE WHEEL
12.	320-0008	2	AXLE, CAGE WHEEL
13.	-----	2	CAGE WHEEL BOLT
14.	300-0024	2	DECK LIFT ARM BACK ADJUSTABLE
15.	300-0013	2	BUSHING, DECK LIFT ARM
16.	300-0014	1	CROSSBAR
17.	330-0012	1	BELT TIGHTENER
18.	300-0016	1	SPACER, IDLER
19.	900-2514	1	PULLEY, GEAR BOX (IN-PUT)
20.	900-2510	1	PULLEY, GEAR BOX (OUT-PUT)
21.	900-2522	1	PULLEY, IDLER (SMALL)
22.	900-2511	3	PULLEY, SPINDLE
23.	300-0017	3	WASHER, SPINDLE
24.	900-3506	6	BEARING, SPINDLE
25.	300-0027	3	SPACER, SPINDLE
26.	300-0025	3	HOUSING, SPINDLE
27.	300-0026	2	SHAFT, SPINDLE
28.	900-5528	3	BLADE
29.	300-0021	3	KEY, SPINDLE
30.	900-3005	1	DECK BELT (EARLY 82 MODELS)
30.	900-3005B	1	DECK BELT (NEW MODELS)
31.	900-3004	1	DRIVE BELT
32.	900-5518	2	CABLE, DECK
33.	900-5519	2	PINS, DECK
34.	900-5520	6	HAIR PINS
35.	900-5536	4	PINS, CAGE WHEEL
36.	900-4020	2	CAGE WHEEL
37.	900-5535	1	GEAR BOX
38.	300-0022	1	CROSS BAR PIN
39.	300-0023L.H.	1	DECK LIFT ARM FRONT ADJUSTABLE
40.	300-0023R.H.	1	DECK LIFT ARM FRONT ADJUSTABLE
41.	320-0009	1	COVER, RIGHT HAND SIDE
42.	900-2521	1	PULLEY, IDLER (LARGE)
43.	300-0037	1	ROLLER BRACKET
44.	900-5559	1	RUBBER ROLLER
45.	300-0038	1	ROLLER SHAFT
46.	320-0010	1	FOOT GUARD MOUNT

52" DECK

0052-T

52 MOWER DECK ASSEMBLY
0052-T

1984 Through 1986

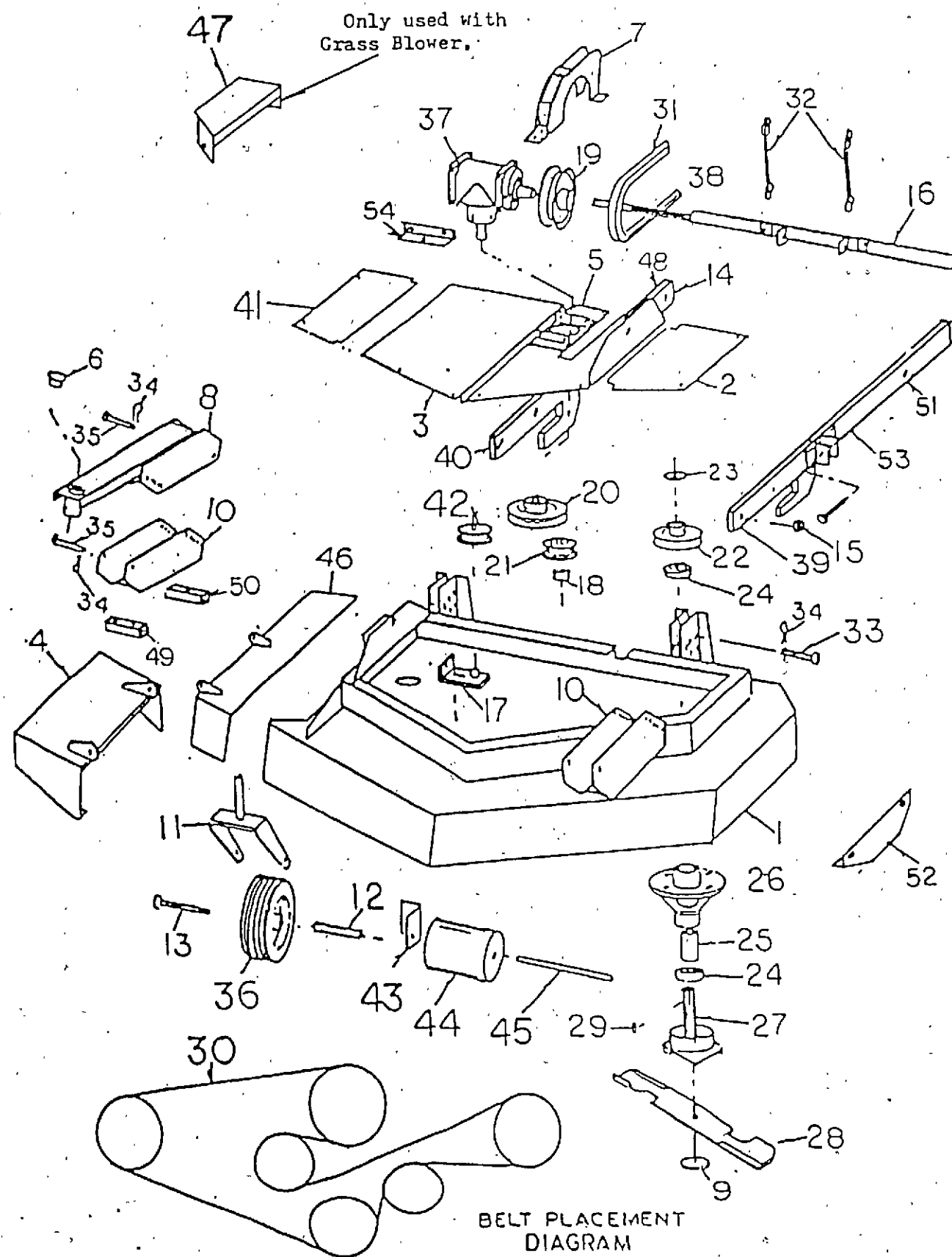

REF. NO.	PART NO.	NO. REQD.	DESCRIPTION
1.	320-0000	1	MOWER DECK
2.	320-0001	1	COVER (SMALL)
3.	320-0002	1	COVER (LARGE)
4.	320-0003	1	FOOT GUARD
5.	320-0004	1	GEAR BOX MOUNT
6.	900-3507	4	GAGE WHEEL BUSHING
7.	311-0002	1	BELT GUARD
8.	320-0005	2	GAGE WHEEL MOUNT
9.	900-5534	3	SPRING WASHER
10.	320-0006	2	BRACKET, GAGE WHEEL MOUNT
11.	320-0007	2	FORK, GAGE WHEEL
12.	320-0008	2	AXLE, GAGE WHEEL
13.	-----	2	GAGE WHEEL BOLT
14.	301-0024	1	DECK LIFT ARM BACK ADJUSTABLE
15.	300-0013	2	BUSHING, DECK LIFT ARM
16.	300-0014	1	CROSS BAR
17.	330-0012	1	BELT TIGHTENER
18.	300-0016	1	SPACER, IDLER
19.	900-2525	1	PULLEY, GEAR BOX (IN-PUT)
20.	900-2510	1	PULLEY, GEAR BOX (OUT-PUT)
21.	900-2522	1	PULLEY, IDLER (SMALL)
22.	900-2511	3	PULLEY, SPINDLE
23.	300-0017	3	WASHER, SPINDLE
24.	900-3506	6	BEARING, SPINDLE
25.	300-0027	3	SPACER, SPINDLE
26.	300-0025	3	HOUSING, SPINDLE
27.	300-0026	2	SHAFT, SPINDLE
28.	900-5528	3	BLADE
29.	300-0021	3	KEY, SPINDLE
30.	900-3005B	1	DECK BELT
31.	900-3004	1	DRIVE BELT
32.	900-5518	2	CABLE, DECK
33.	900-5519	2	PINS, DECK
34.	900-5520	6	HAIR PIN
35.	900-5536	4	PINS, GAGE WHEEL
36.	900-4020	2	GAGE WHEEL
37.	900-5535	1	GEAR BOX
38.	300-0022	1	CROSS BAR PIN
39.	300-0023L.H.	1	DECK LIFT ARM FRONT ADJUSTABLE
40.	300-0023R.H.	1	DECK LIFT ARM FRONT ADJUSTABLE
41.	320-0009	1	COVER, RIGHT HAND SIDE
42.	900-2521	1	PULLEY, IDLER (LARGE)
43.	300-0037	1	ROLLER BRACKET
44.	900-5559	1	RUBBER ROLLER
45.	300-0038	1	ROLLER SHAFT
46.	320-0010	1	FOOT GUARD MOUNT
47.	320-0011	1	COVER, DECK BLOWER PULLEY
48.	330-0024R.H.	1	DECK LIFT ARM BACK ADJUSTABLE (1600 1800)
49.	320-0012	2	GAGE WHEEL BRACKET SPACER 2 HOLE
50.	320-0013	2	GAGE WHEEL BRACKET SPACER 1 HOLE
51.	330-0024L.H.	1	DECK LIFT ARM BACK ADJUSTABLE (1600 1800)
52.	320-0014	1	SHOE, LEFT HAND SIDE
53.	320-0024L.H.	1	DECK LIFT ARM BACK ADJUSTABLE (1600 1800)
54.	310-0006	1	GEARBOX MOUNT ANGLE

NOTE: IF YOU HAVE INFLATABLE GAGE WHEELS, REFER TO 62 DECK ASSEMBLY DRAWING FOR ITEMS 6, 8, 11, 12 & 36 FOR PART NUMBER

0052T & 0052TC
G52T & G52TC
52" DECK PARTS

1987 - 1991

Item	Part No.	Description	Qty.	Item	Part No.	Description	Qty.
1	G320000C	Deck, 52"	1		G9004006	Tire, 11 x 4.00-5	2
2	G3200015G	Foot Guard	1		G9004005	Rim, 5"	-
3	G3200016G	Foot Guard Mount	1		G9003505	Bearing, Wheel Assembly	-
4	G3200011G	Pulley Cover	1	15	J10018H5C	Hex Bolt, 1/4-20 x 4 1/2", GR5 (0052T and G52A Deck)	2
5	G3200002G	Center Cover	1		314022C	Hex Bolt, 1/4-20 x 4 1/2", GR5 (0052T & G52A Deck)	2
6	G3200001G	Cover, LH	1	16	G9006096	Wing Bolt	4
7	G3200014	Shoe, LH	1	17	G9006092	Handle Nut	4
8	G9005559	Anti-scalp Roller	1	18	G9002044	10 Amp Circuit Breaker	1
9	G3000038	Shaft & Bracket	1	19	G9005510	Set Collar, 1"	2
10	G3000044	Gauge Wheel Mount Bracket	2	20	G9003501	Bearing, 1"	4
11	G3000043	Gauge Wheel Mount	2	21	G9005615	Fas-tatch Pin	1
12	G3200018	Fork (0052T & G52A Deck)	2	22	G9005519	Deck Pin	2
	G3300007	Fork (0052TC & G52AC Deck)	-	23	G9005520	Hair Pin Cotter	2
13	G3200008	Axle (0052T & G52A Deck)	2	24	G9006043	Thumb Screw, 1/4-20 x 1/2"	4
	G2000017	Axle (0052TC & G52AC Deck)	-	25	G9006020	Wing Screw, 1/2-20 x 1"	1
14	G9004020	Gauge Wheel Ass'y. (0052T & G52A Deck)	2				
	G9003510	Wheel Assembly Bearing	-				
	G9004004	Gauge Wheel Ass'y. (0052TC & G52AC Deck)	2				

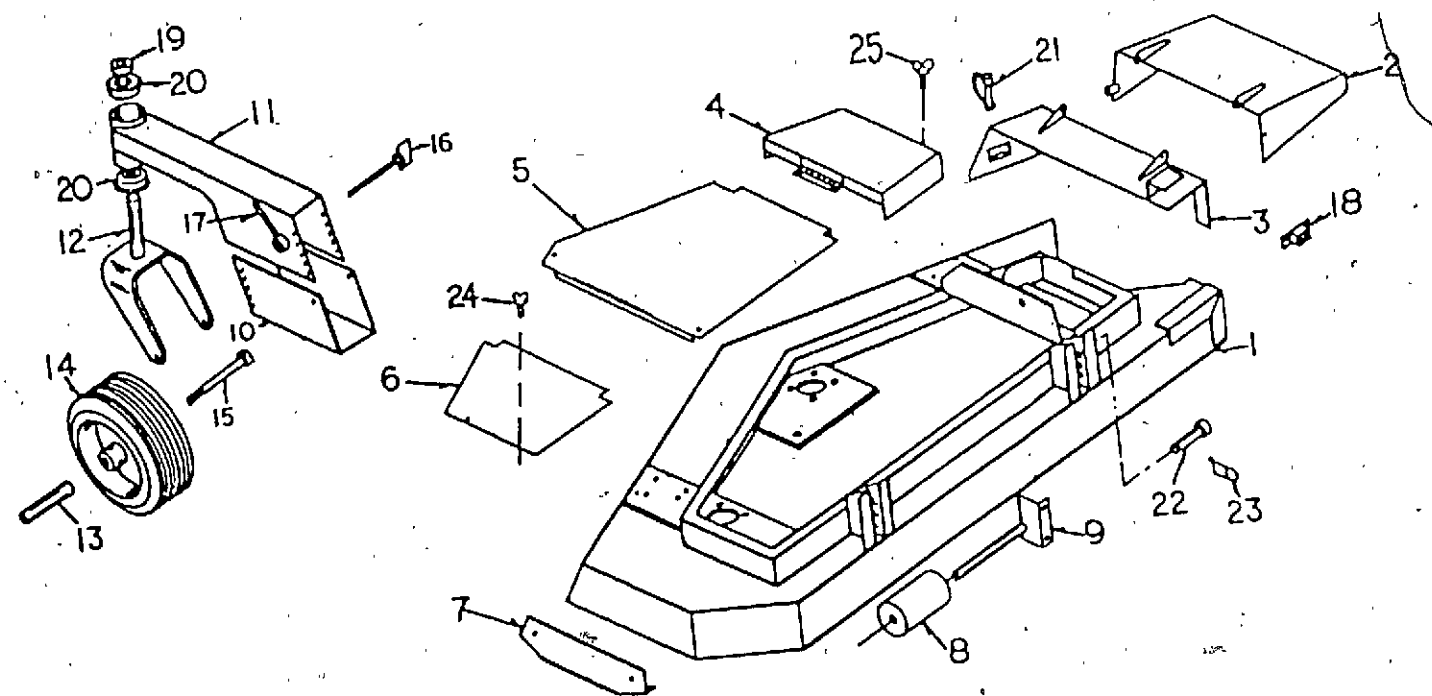

0052T & 0052TC
G52T & G52TC
52" DECK DRIVE

1987 - 1991

Item	Part No.	Description	Qty.	Item	Part No.	Description	Qty.
1	G3210001G	Gearbox Mount (Serial Numbers 09-08-0945 & Up)	1	15	G9002522	Idler Pulley, Small - 3.4"	1
	G3200004G	Gearbox Mount (Serial Numbers Prior to 09-08-0945)	1	16	G9003005B	Deck Belt	1
2	G3110002	Belt Guard	1	17	G9003004	Deck Drive Belt	1
3	G3100006	Gearbox Mount Angle	1	18	G9005842	Gearbox	1
4	G3300012	Belt Tightener	1	19	G9006002	Spacer Washer	12
5	G3000025	Spindle Housing	3	20	300115C	Hex Tap Bolt, 1/4-20 x 4"	1
6	G3000027	Spindle Spacer	3	21	30103H5C	Hex Bolt, 5/16-24 x 3/4", GR5	3
7	G3000026	Spindle Shaft	2	22	G3000017	Washer, 5/16", 10 GA	3
8	G3000033	Spindle Shaft, Long	1	23	G9005534	Blade Washer	3
9	G9003506	Spindle Bearing, 7/8"	6	24	30206H5C	Hex Bolt, 3/8-24 x 1 1/4", GR5	3
10	G9005528	Blade	3	25	40611	Key, 3/16" x 1"	6
11	G9002511	Spindle Pulley	4	26	G3000016	Spacer, Idler Pulley	1
12	G9002510	Gearbox Pulley, Output	1		G6000000	Spindle Housing Ass'y. (Includes Item 5, 6 & 9)	3
13	G9002525	Gearbox Pulley, Input	1		G6000023G	Gearbox Mount Ass'y. (Includes Items 1, 3, 12, 13 & 18)	1
14	G9002521	Idler Pulley, Large	1				

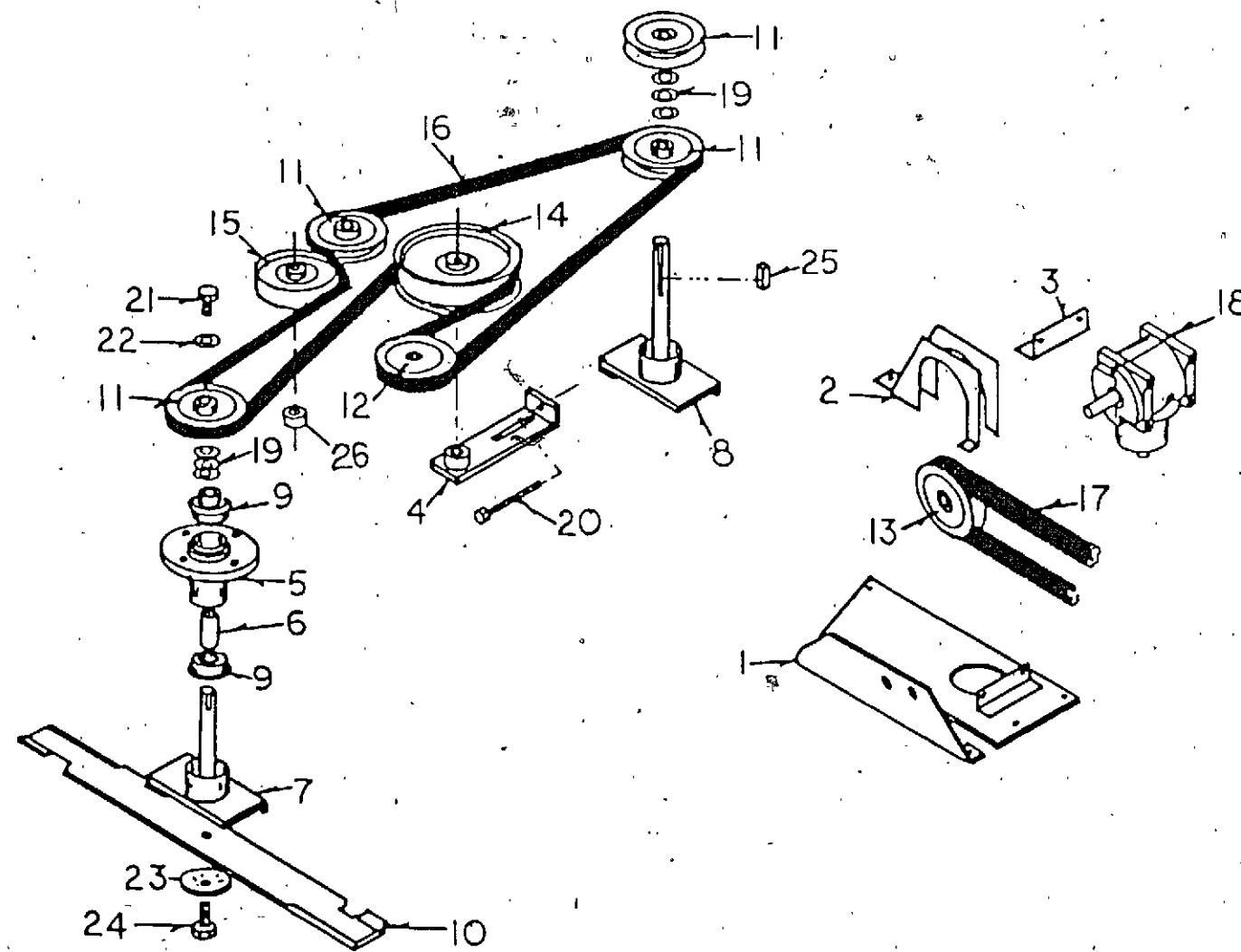

MOWER DECK AND ATTACHING PARTS (52")
(USED ON CHAIN DRIVE MOWERS)

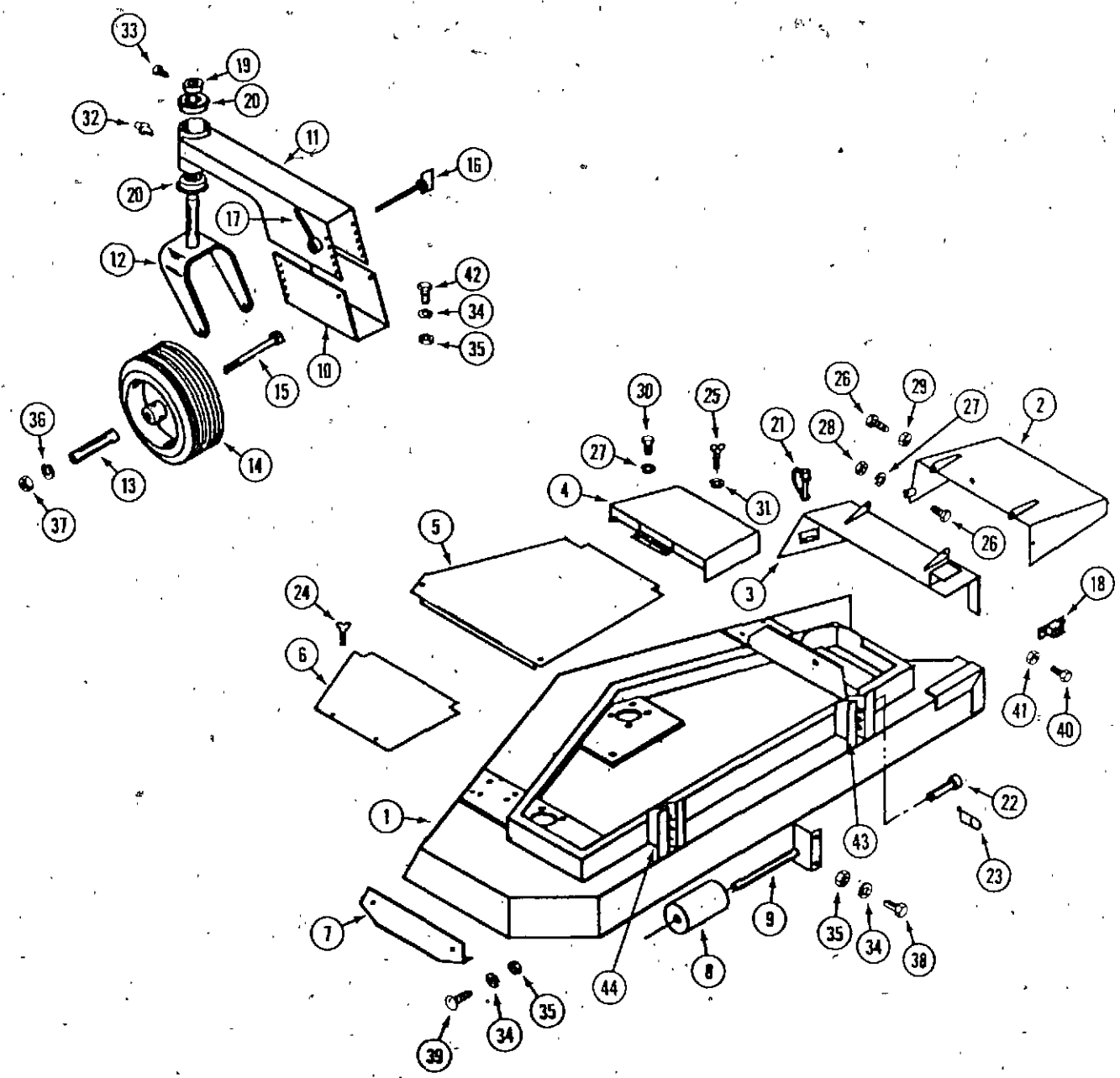

REF.	PART NO.	DESCRIPTION	REQ'D
1	C 39210	DECK - 52"	1
2	C 44612	CHUTE - foot guard	1
3	C 39209	MOUNT - foot guard	1
4	C 38066	COVER - pulley	1
5	C 39203	COVER - center	1
6	C 39200	COVER - L.H.	1
7	C 37942	SHOE - skid	1
8	C 37910	ROLLER - anti-scalp	1
9	C 37911	SHAFT - roller	1
10	C 37912	BRACKET - gauge wheel mount	2
11	C 37913	MOUNT - gauge wheel	2
12	C 37914	FORK - (52AC, 52TCSS)	2
12	C 38030	FORK - (52A)	2
13	C 37915	AXLE - wheel (52AC, 52TCSS)	2
13	C 38031	AXLE - wheel (52A)	2
14	C 37916	WHEEL - gauge (52AC, 52TCSS)	2
14	C 38039	WHEEL - gauge (52A)	3
	C 37917	TIRE - 11 x 4.00 - 5	1
	C 37918	RIM - 5"	1
	C 44499	BEARING - wheel (52AC, 52TCSS)	2
	C 38033	BEARING - wheel (52A)	2
15	113- 54	BOLT - 1/4" - 20 x 4-1/2" (52A)	2
15	113- 2419	BOLT - 1/2" - 13 x 6-1/2" (52AC, 52TCSS)	2
16	C 37920	BOLT - wing	4
17	C 37921	NUT - gauge wheel handle	4
18	C 37505	BREAKER - circuit, 10 amp	1
19	C 37860	COLLAR - set	2
20	C 37824	BEARING - 1"	4
21	C 37922	PIN - "fas-tatch"	1
22	141- 56	PIN - deck	1
23	C 38096	PIN - cotter, hair	2
24	NSS	SCREW - thumb 1/4" - 20 x 1/2" (use 113-3 and 192-19)	4
25	NSS	SCREW - wing 1/4" - 20 x 1" (use 113-3 and 192-19)	1
26	113- 3	BOLT - 1/4" - 20 x 3/4"	4
27	192- 19	LOCKWASHER - 1/4"	2
28	129- 101	NUT - 1/4" - 20	2
29	131- 71	NUT - 1/4" - 20 lock	2
30	113- 1	BOLT - 1/4" - 20 x 1"	2
31	195- 102	WASHER - 1/4"	1
32	C 37993	FITTING - grease	2
33	C 37756	SCREW - set 5/16" - 18 x 1/2" square head	2
34	192- 20	LOCKWASHER - 5/16"	6
35	129- 102	NUT - 5/16" - 18	6
36	192- 23	LOCKWASHER - 1/2"	2
37	129- 105	NUT - 1/2" - 13	2
38	113- 102	BOLT - 5/16" - 18 x 3/4"	2
39	111- 202	BOLT - 5/16" - 18 x 3/4" carriage	2
40	182- 528	SCREW - #10 - 32 x 1/2"	2
41	193- 1000	NUT - #10 - 32	2
42	111- 203	BOLT - 5/16" - 18 x 1" carriage	6
43	C 39221	BRACKET - height adjust R.H.	2
44	C 39222	BRACKET - height adjust L.H.	2

MOWER DRIVE (52'')
(USED ON CHAIN DRIVE MOWERS)

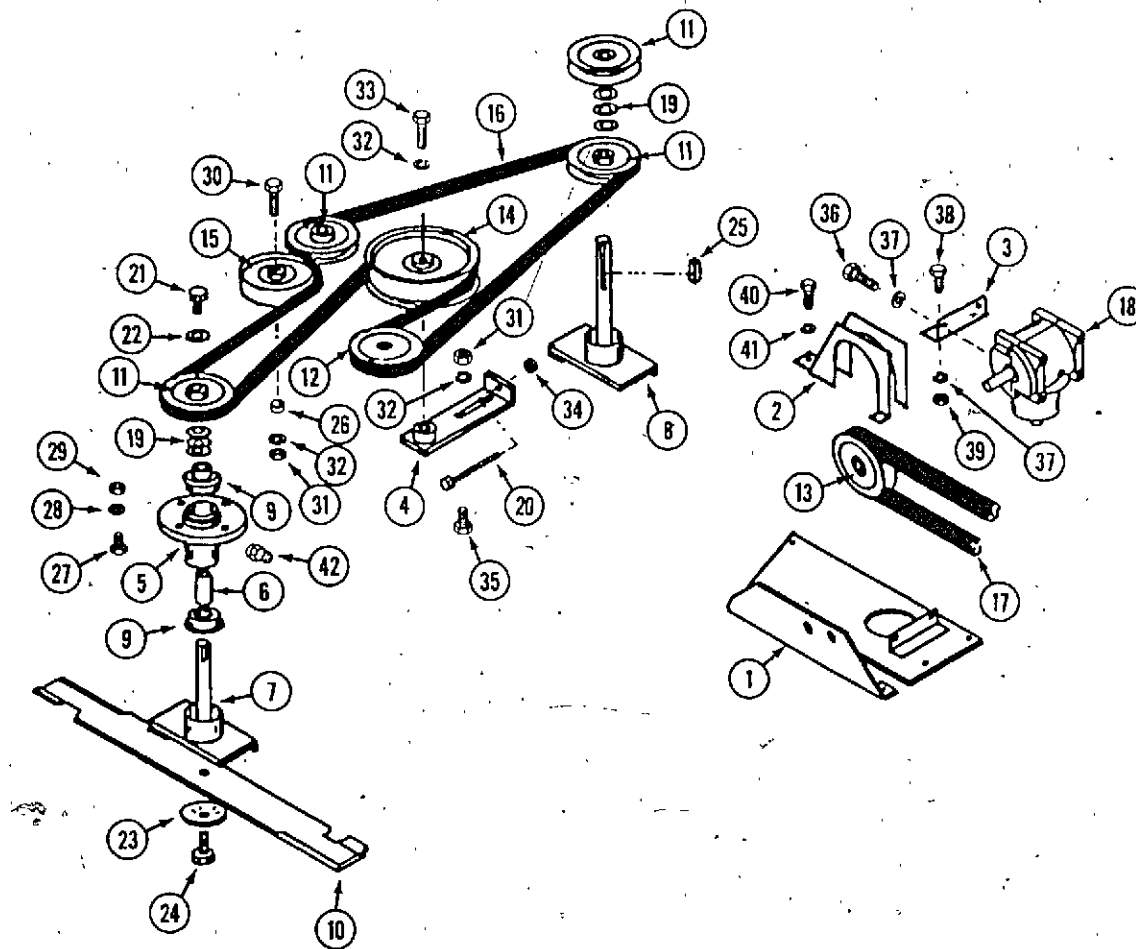

REF.	PART NO.	DESCRIPTION	REQ'D
1	C 38070	MOUNT - gear box (use before S/N 09-08-0945)	1
1	C 39205	MOUNT - gear box (use S/N 09-08-0945 and after)	1
2	C 37875	GUARD - belt (early production)	1
3	C 37877	ANGLE - gear box mount	1
4	C 37929	TIGHTENER - belt	1
5	C 37902	HOUSING ASSEMBLY - spindle (included 6, 9, 42)	3
5	C 37880	HOUSING - spindle	3
6	C 37881	SPACER - spindle	3
7	C 37883	SHAFT - spindle short (use before S/N 013306046)	2
7	C 44128	SHAFT - spindle, short (use S/N 013306046 and after)	2
8	C 37884	SHAFT - spindle, long (use before S/N 013306046)	1
8	C 44130	SHAFT - spindle, long (use S/N 013306046 and after)	1
9	C 42786	BEARING - spindle	3
10	C 37930	BLADE - mower (use before S/N 013306046)	3
10	C 44136	BLADE - mower (use S/N 013306046 and after)	3
11	C 37931	PULLEY - spindle	4
12	C 37932	PULLEY - gear box output	1
13	C 37892	PULLEY - gear box input	1
14	C 37933	PULLEY - idler, large	1
15	C 37934	PULLEY - idler, small	1
16	C 37935	BELT - deck	1
17	C 37894	BELT - drive	1
18	C 44917	GEAR BOX - angle drive (see page 53 for repairs)	1
19	C 37888	SPACER - washer	12
20	C 37901	BOLT - 1/4" - 20 x 4"	1
21	114- 102	BOLT - 5/16" - 24 x 3/4"	3
22	C 26344	WASHER - 5/16" - 10 ga.	3
23	C 37886	WASHER - blade (use before S/N 013306046)	3
24	113- 268	BOLT - 3/8" - 16 x 1" also requires 131-1216 locknut (use S/N 013306046 and after)	6
24	114- 201	BOLT - 3/8" - 24 x 1-1/4" (use before S/N 013306046)	3
25	C 29581	KEY - 3/16" x 1"	6
26	C 37937	SPACER - idler pulley	1
27	113- 312	BOLT - 7/16" - 14 x 1-1/4"	12
28	192- 22	LOCKWASHER - 7/16"	12
29	129- 104	NUT - 7/16" - 14"	12
30	113- 257	BOLT - 3/8" - 16 x 2-1/2"	1
31	129- 103	NUT - 3/8"	1
32	192- 21	LOCKWASHER - 3/8"	1
33	113- 208	BOLT - 3/8" - 16 x 1-1/4"	1
34	131- 71	NUT - 1/4" - 20 lock	1
35	111- 371	BOLT - 3/8" - 16 x 1" carriage	1
36	113- 102	BOLT - 5/16" - 18 x 3/4"	4
37	192- 20	LOCKWASHER - 5/16"	5
38	113- 102	BOLT - 5/16" - 18 x 3/4"	1
39	129- 102	NUT - 5/16" - 18"	1
40	113- 1	BOLT - 1/4" - 20 x 1/2"	2
41	192- 19	LOCKWASHER - 1/4"	2
42	219- 20	FITTING - grease 1/4" - 28	3

52" DECK PARTS
(USED ON HYDRAULIC DRIVE MOWERS)

Item	Part No.	Description	Qty.	Item	Part No.	Description	Qty.
1	G320000G	Deck, 52"	1		G9004006	Tire, 11 x 4.00-5	-
2	G3200015G	Foot Guard	1		G9004005	Rim, 5"	-
3	G3200016G	Foot Guard Mount	1		G9003505	Bearing, Wheel Assembly	-
4	G3200011G	Pulley Cover	1	15	314022C	Hex Bolt, 1/2-13 x 6 1/2", GR2	2
5	G3200002G	Center Cover	1	16	G9006096	Wing Bolt	4
6	G3200001G	Cover, LH	1	17	G9006092	Handle Nut	4
7	G3200014	Shoe, LH	1	18	G9002044	10 Amp Circuit Breaker	1
8	G9005559	Anti-scalp Roller	1	19	G9005510	Set Collar, 1/2"	2
9	G3000038	Shaft & Bracket	1	20	G9003501	Bearing, 1"	4
10	G3000044	Gauge Wheel Mount Bracket	2	21	G9005615	Fas-tatch Pin	1
11	G3000043	Gauge Wheel Mount	2	22	G9005519	Deck Pin	2
12	G3300007	Fork	2	23	G9005520	Hair Pin Cotter	2
13	G2000017	Axle	2	24	G9006043	Thumb Screw, 1/4-20 x 1/2"	4
14	G9004004	Gauge Wheel Assembly	2	25	G9006020	Wing Screw, 1/4-20 x 1"	1

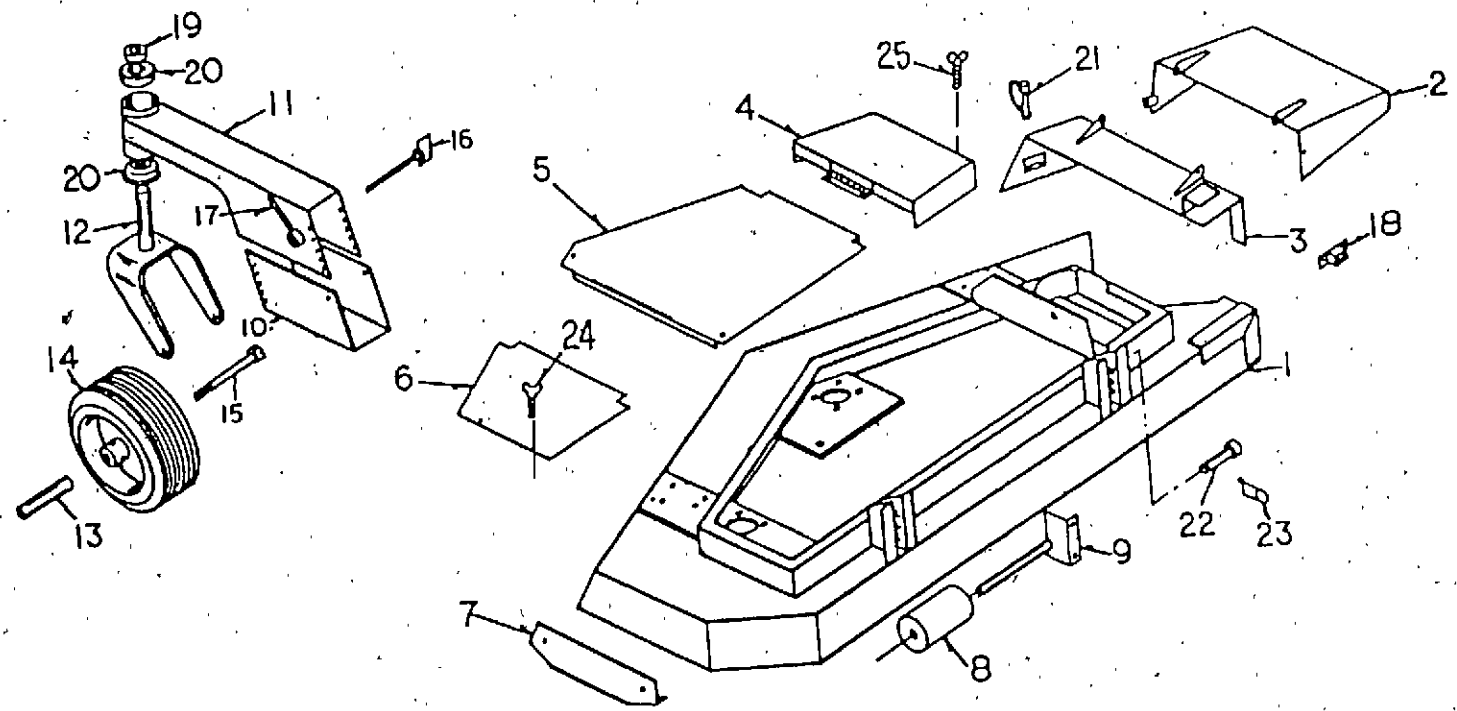

52" DECK DRIVE
(USED ON HYDRAULIC DRIVE MOWERS)

Item	Part No.	Description	Qty.	Item	Part No.	Description	Qty.
1	G3210001G	Gearbox Mount	1	15	G9002522	Idler Pulley, Small	1
2	G3110002	Belt Guard (1800)	1	16	G9003005B	Deck Belt	1
	G3300030	Belt Guard (2000)	1	17	G9003004	Deck Drive Belt (1800)	1
3	G3100006	Gearbox Mount Angle	1		G9003009	Deck Drive Belt (2000)	2
4	G3300012	Belt Tightener	1	18	G9005535	Gearbox	1
5	G3000025	Spindle Housing	3	19	G9006002	Spacer Washer	12
6	G3000027	Spindle Spacer	3	20	300115C	Hex Tap Bolt, 1/4-20 x 4"	1
7	G3000026	Spindle Shaft	2	21	30103H5C	Hex Bolt, 5/16-24 x 3/4", GR5	3
8	G3000033	Spindle Shaft, Long	1	22	G3000017	Washer, 5/16", 10 GA	3
9	G9003506	Spindle Bearing	6	23	G9005534	Blade Washer	3
10	G9005814	Blade	3	24	30206H5C	Hex Bolt, 3/8-24 x 1 1/4", GR5	3
11	G9002511	Spindle Pulley	4	25	40611	Key, 3/16" x 1"	6
12	G9002510	Gearbox Pulley, Output	1	26	G3000016	Spacer, Idler Pulley	1
13	G9002525	Gearbox Pulley, Input (1800)	1		G6000000	Spindle Housing Assembly, (Includes Items 5, 6 & 9)	3
	G9002543	Gearbox Pulley, Input (2000)	1				
14	G9002521	Idler Pulley, Large	1				

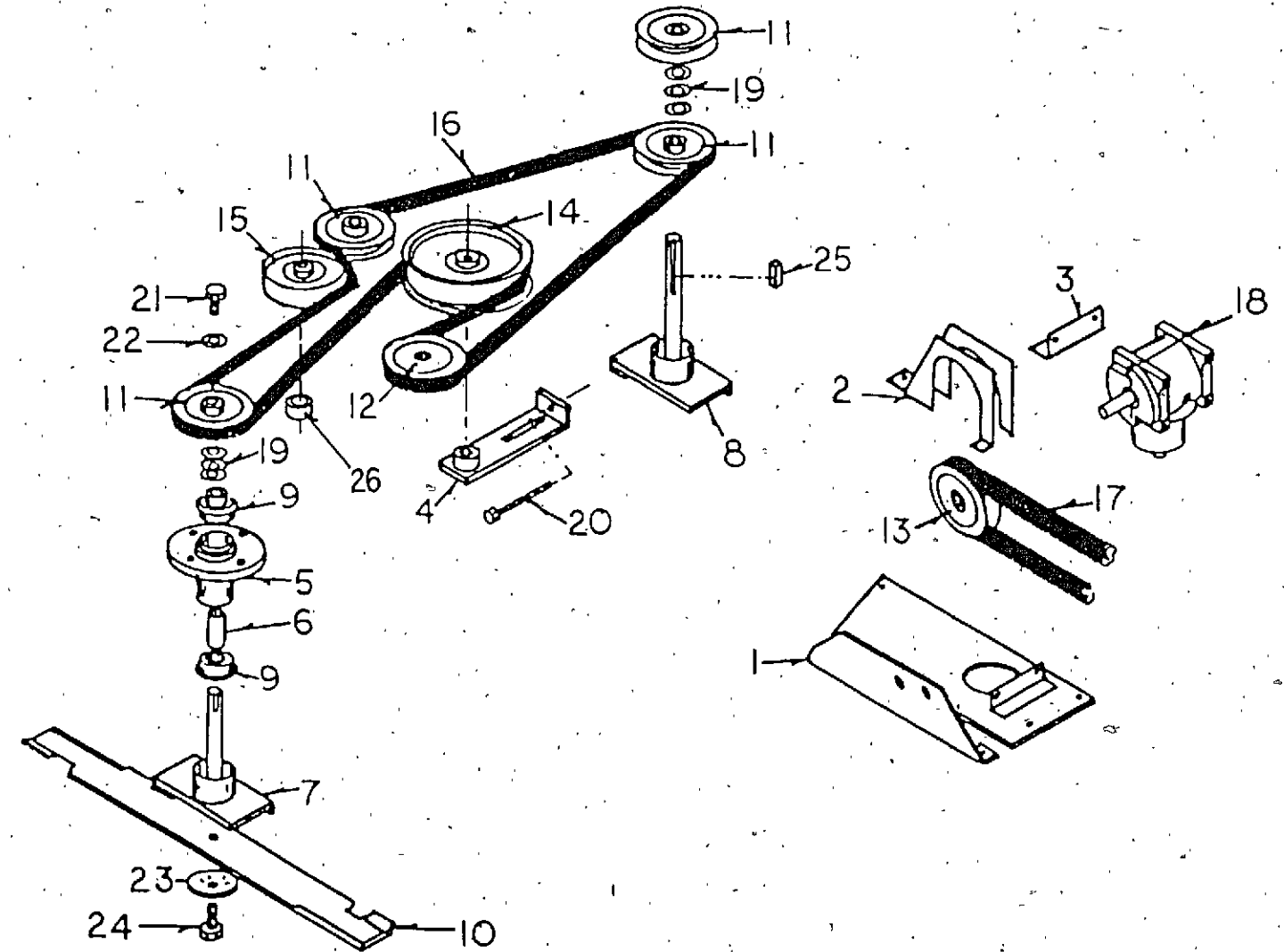

0052TCSS & 0052TCII

1992 AND AFTER

52" MOWER DECK AND ATTACHING PARTS
(USED ON HYDRAULIC DRIVE MOWERS)

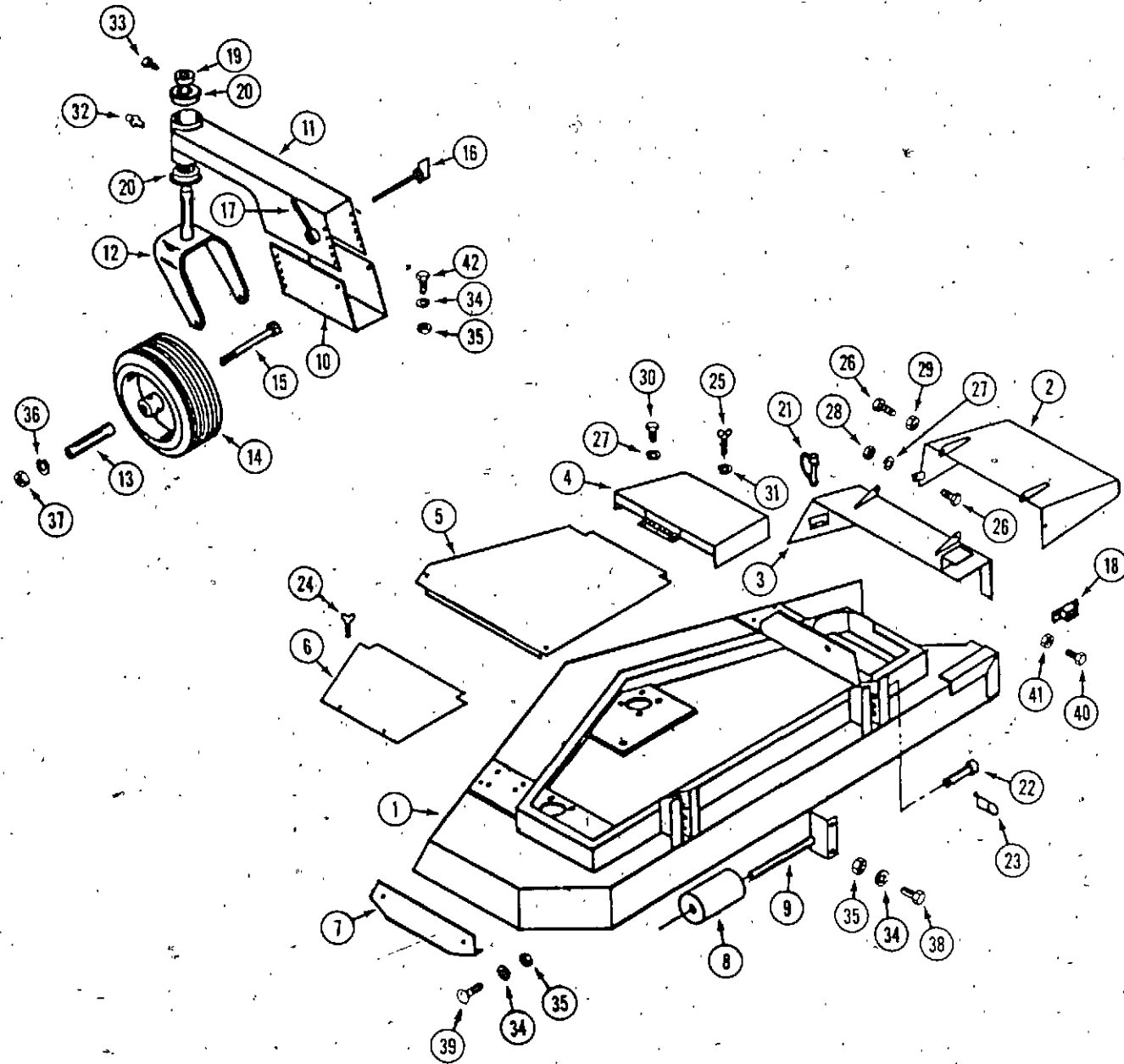

REF.	PART NO.	DESCRIPTION	REQ'D
1	C 44086	DECK - 52"	1
2	C 39208	CHUTE - foot guard	1
3	C 39209	MOUNT - foot guard	1
4	C 39204	COVER - pulley	1
5	C 39203	COVER - center	1
6	C 39200	COVER - L.H.	1
7	C 37942	SHOE - skid	1
8	C 37910	ROLLER - anti-scalp	1
9	C 37911	SHAFT - roller	1
10	C 37912	BRACKET - gauge wheel mount	2
11	C 37913	MOUNT - gauge wheel	2
12	C 37914	FORK	2
13	C 37915	AXLE - wheel	2
14	C 37916	WHEEL - gauge	2
	C 37917	TIRE - 11 x 4.00 - 5	1
	C 37918	RIM - 5"	1
	C 44499	BEARING - wheel	2
15	113- 2419	BOLT - 1/2" - 13 x 6-1/2"	2
16	C 37920	BOLT - wing	4
17	C 37921	NUT - gauge wheel handle	4
18	C 37505	BREAKER - circuit, 10 amp	1
19	C 37860	COLLAR - set	2
20	C 37824	BEARING - 1"	4
21	C 37922	PIN - "fas-tatch"	1
22	C 10821	PIN - deck	1
23	C 29029	PIN - cotter, hair	2
24	NSS	SCREW - thumb 1/4" - 20 x 1/2" (use 113-3 and 192-19)	4
25	NSS	SCREW - wing 1/4" - 20 x 1" (use 113-3)	1
26	113- 3	BOLT - 1/4" - 20 x 3/4"	4
27	192- 19	LOCKWASHER - 1/4"	2
28	129- 101	NUT - 1/4" - 20	2
29	131- 71	NUT - 1/4" - 20 lock	2
30	113- 1	BOLT - 1/4" - 20 x 1"	2
31	195- 102	WASHER - 1/4"	1
32	C 37993	FITTING - grease	2
33	C 37756	SCREW - set 5/16" - 18 x 1/2" square head	2
34	192- 20	LOCKWASHER - 5/16"	6
35	129- 102	NUT - 5/16" - 18	6
36	192- 23	LOCKWASHER - 1/2"	2
37	129- 105	NUT - 1/2" - 13	2
38	113- 102	BOLT - 5/16" - 18 x 3/4"	2
39	111- 202	BOLT - 5/16" - 18 x 3/4" carriage	2
40	182- 528	SCREW - #10 - 32 x 1/2"	2
41	C 37598	NUT - #10 - 32	2
42	111- 203	BOLT - 5/16" - 18 x 1" carriage	6

52" MOWER DRIVE
(USED ON HYDRAULIC DRIVE MOWERS)

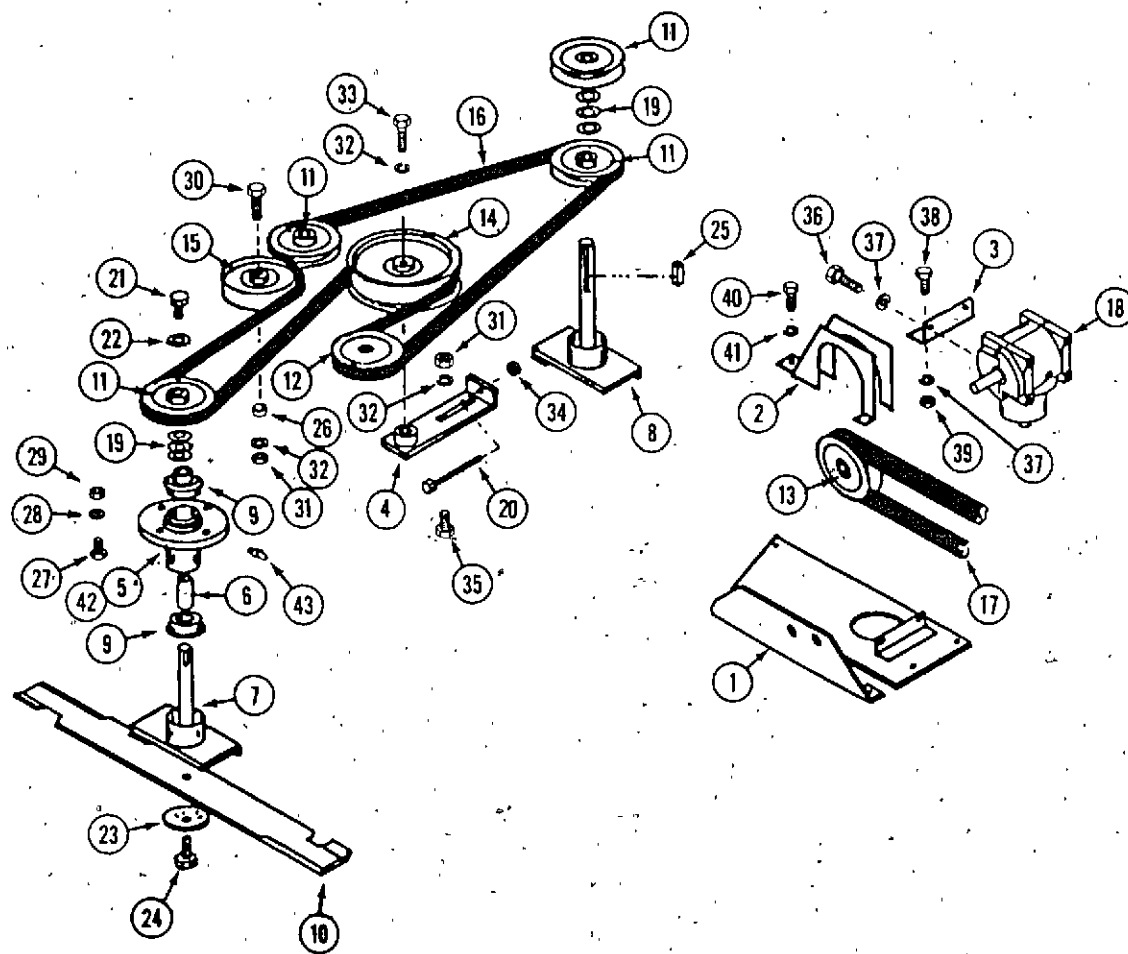

REF.	PART NO.	DESCRIPTION	REQ'D
1	C 39205	MOUNT - gear box	1
2	C 37875	GUARD - belt (1800SS, 1800KSS, 1890, 1890K)	1
2	C 37876	GUARD - belt (2000)	1
3	C 37877	ANGLE - gear box mount	1
4	C 37929	TIGHTENER - belt	1
5	C 37880	HOUSING - spindle	3
6	C 37881	SPACER - spindle	3
7	C 37883*	SHAFT - spindle, short	2
7	C 44128**	SHAFT - spindle, short	1
8	C 37884*	SHAFT - spindle, long	1
8	C 44130**	SHAFT - spindle, long	1
9	C 42786*	BEARING - spindle	3
10	C 37930	BLADE - mower	3
10	C 44136**	BLADE - mower	1
11	C 37931	PULLEY - spindle	4
12	C 37932	PULLEY - gear box output	1
13	C 37892	PULLEY - gear box input (1800SS, 1800KSS, 1890, 1890K, 1890V)	1
13	C 37893	PULLEY - gear box input (2000)	1
14	C 37933	PULLEY - idler, large	1
15	C 37934	PULLEY - idler, small	1
16	C 37935	BELT - deck	1
17	C 37894	BELT - drive (1800SS, 1800KSS, 1890, 1890K)	1
17	C 37895	BELT - drive (2000)	2
17	C 44241	BELT - drive (1890V)	1
18	C 37898	GEAR BOX - angle drive (see page 83 for repairs) (Curtis model)	1
18	C 42775	GEAR BOX - angle drive (repairs page 83) (Superior model)	1
19	C 37888	SPACER - washer	12
20	C 37901	BOLT - 1/4" - 20 x 4"	1
21	C 39386	BOLT - 5/16" - 24 x 3/4" lock	3
22	C 37900	WASHER - 5/16" - 10 ga.	3
23	C 37886*	WASHER - blade	3
24	C 37557*	BOLT - 3/8" - 24 x 1-1/4"	3
24	113- 268**	BOLT - 3/8" - 16 x 1" (also required 131-1216 locknut)	6
25	C 29581	KEY - 3/16" x 1"	6
26	C 37937	SPACER - idler pulley	1
27	113- 312	BOLT - 7/16" - 14 x 1-1/4"	12
28	192- 22	LOCKWASHER - 7/16"	12
29	129- 104	NUT - 7/16" - 14	12
30	113- 257	BOLT - 3/8" - 16 x 2-1/2"	1
31	129- 103	NUT - 3/8"	1
32	192- 21	LOCKWASHER - 3/8"	1
33	113- 208	BOLT - 3/8" - 16 x 1-1/4"	1
34	131- 71	NUT - 1/4" - 20 lock	1
35	111- 371	BOLT - 3/8" - 16 x 1" carriage	1
36	113- 103	BOLT - 5/16" - 18 x 1"	4
37	192- 20	LOCKWASHER - 5/16"	5
38	113- 102	BOLT - 5/16" - 18 x 3/4"	1
39	129- 102	NUT - 5/16" - 18	1
40	113- 1	BOLT - 1/4" - 20 x 1/2"	2
41	192- 19	LOCKWASHER - 1/4"	2
42	C 37902	HOUSING ASSEMBLY - spindle (includes ref. 5, 6, 9)	3
43	219- 20	FITTING - grease 1/4" - 28	3

*use before S/N: 013306046
**use S/N: 013306046 and after

DECALS (Deck)

REF.	PART NO.	DESCRIPTION	REQ'D
1	C 37491	DECAL - "Whirling Blades"	1
2	C 37492	DECAL - "Caution" discharge chute	1
3	C 37493	DECAL - "Caution" grass chute	1
4	C 37494	DECAL - "Danger"	1

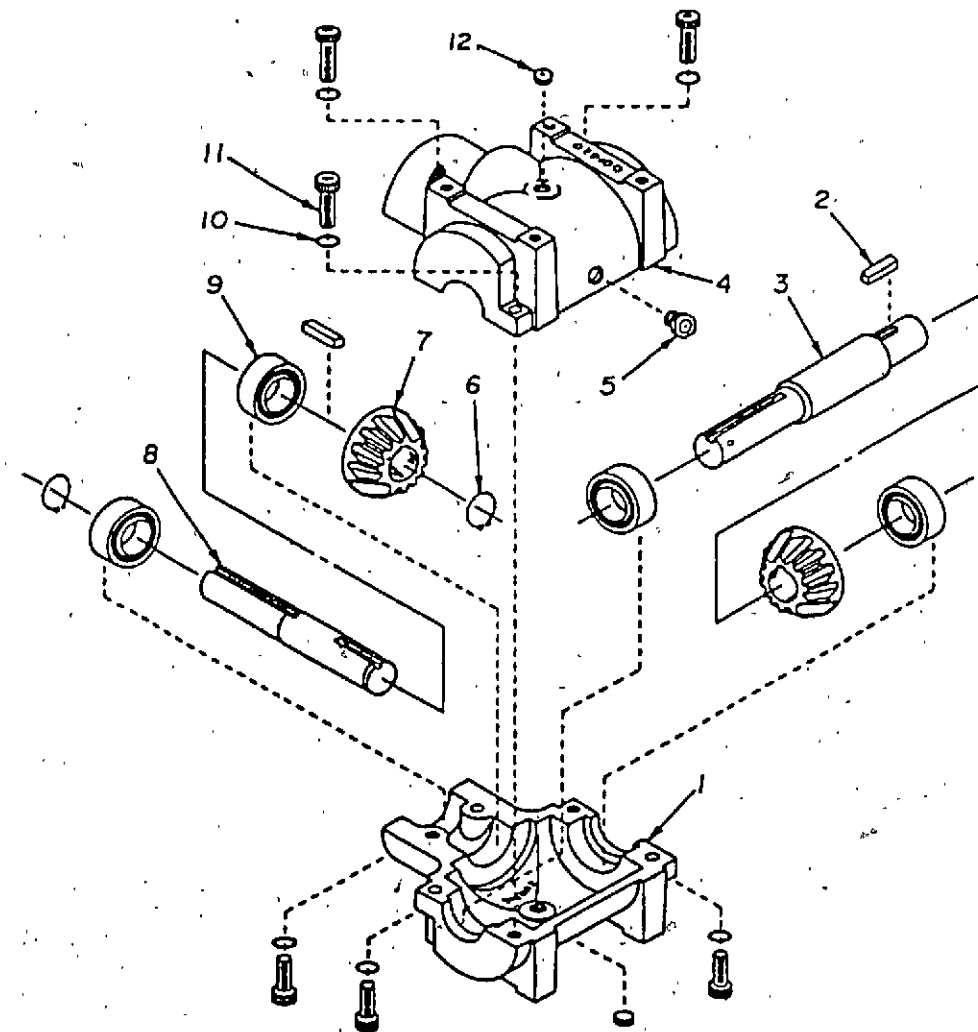
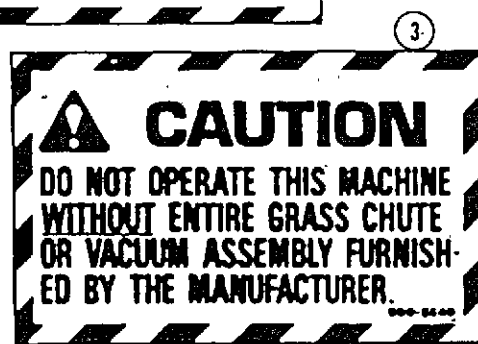
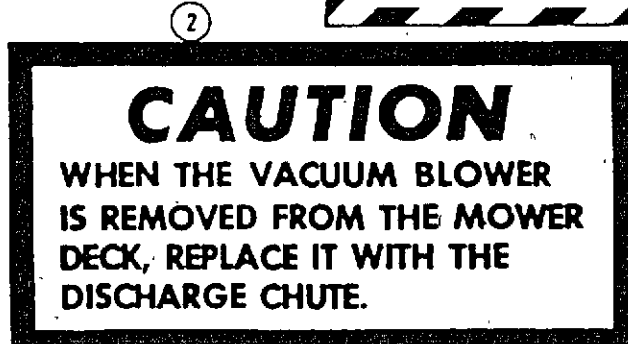

REF. NO.	PART NO.	DESCRIPTIONS
1.	900-7000	HOUSING HALF
2.	900-7001	KEY
3.	900-7002	SHAFT
4.	900-7003	HOUSING HALF
5.	900-7004	RELIEF VALVE
6.	900-7005	RETAINING RING
7.	900-7006	GEAR
8.	900-7007	SHAFT
9.	900-7008	BALL BEARING
10.	900-7009	LOCKWASHER
11.	900-7010	ALLEN HEAD BOLT
12.	900-7011	PIPE PLUG

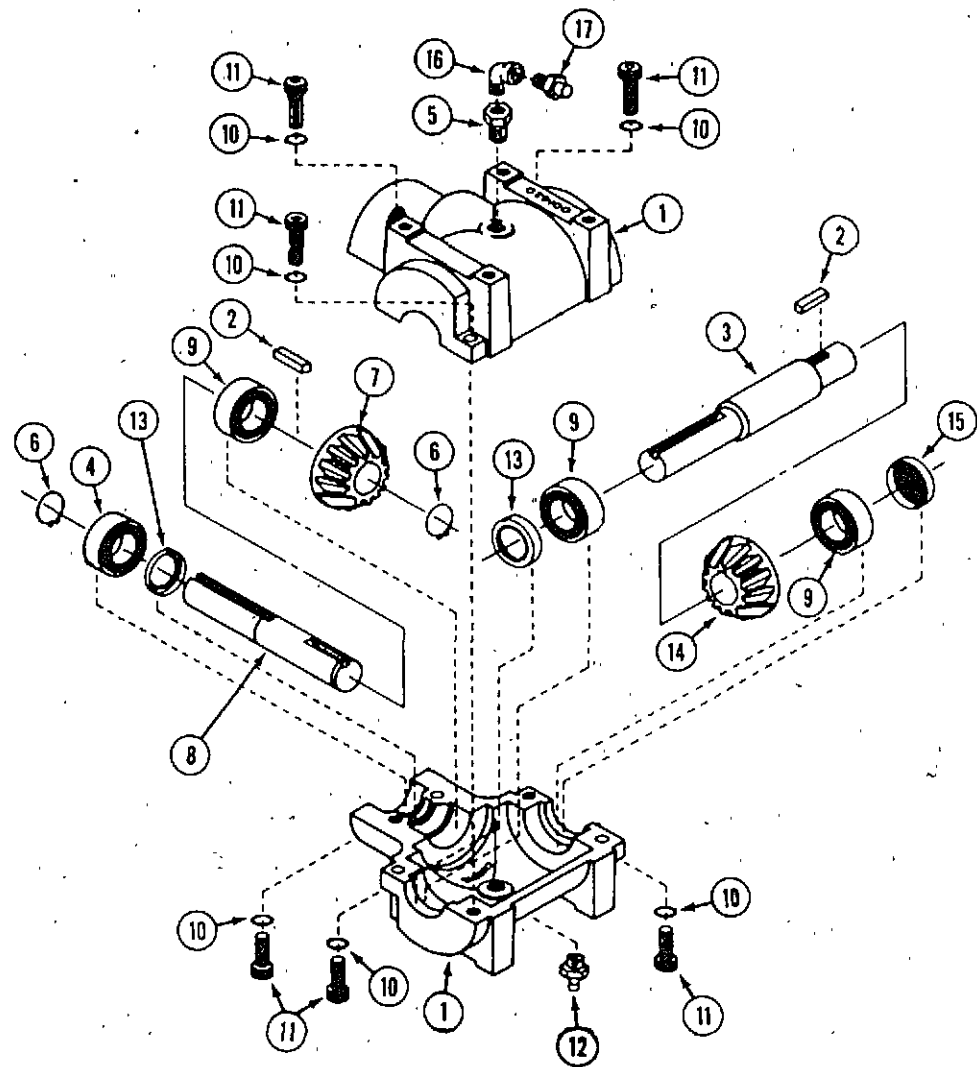

**GEAR BOX
(Curtis)**

1988 AND AFTER

REF.	PART NO.	DESCRIPTION	REQ'D
	C 37898	GEAR BOX	1
1	C 37959	HOUSING - half	2
2	C 29581	KEY - 3/16" x 3/16" x 1"	2
3	C 37960	SHAFT - input	1
4	C 37961	BEARING - ball	1
5	C 37962	BUSHING - pipe 1/4" x 1/8"	1
6	C 37963	RING - retaining	2
7	C 37964	GEAR - output shaft	1
8	C 37965	SHAFT - output	1
9	C 37966	BEARING - ball	3
10	C 37967	LOCKWASHER	6
11	C 37968	CAP SCREW - allen head	6
12	C 37974	FITTING - grease 1/4" NPT	1
13	C 37969	SEAL - shaft	2
14	C 37970	GEAR - input shaft	1
15	C 37971	PLUG - expansion	1
16	C 37547	ELBOW - street 1/8" x 90°	1
17	C 37973	VALVE - relief	1
	C 37975	GREASE - synthetic, cartridge	1

**GEAR BOX
(Superior)**

1	C 42924	SHAFT - pinion, with gear	1
2	C 42923	SHAFT - cross, with gear	1
3	C 42917	HOUSING - with tapped holes	1
4	C 42927	HOUSING - with thru holes (not shown)	1
5	C 42918	CUP - bearing	4
6	C 42921	CONE - bearing	4
7	C 42919	RING - retaining	1
8	C 42920	PLUG - pipe 1/4"	3
9	C 42922	SEAL - shaft	2
10	C 29581	KEY - 3/16" x 1" input shaft	1
11	C 42928	PIPE - vent	1
12	C 42926	BOLT - 5/16" x 1" socket head (not shown)	8
13	C 42925	CAP - end	1
14	C 28215	KEY - 3/16" x 5/8" output shaft	1

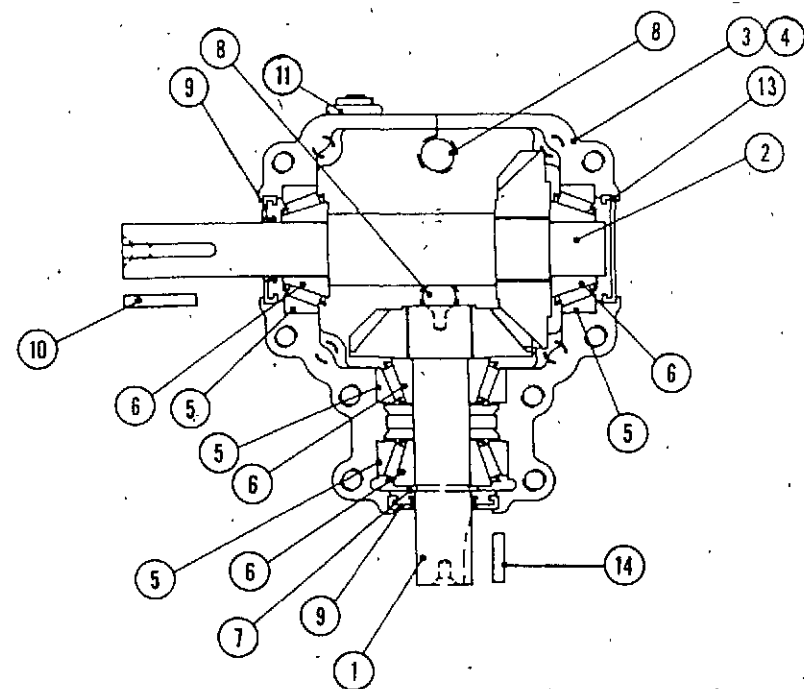



GRAZER GROUND MOWERS

Models

**GI862, 0062T, 62TCSS, 62TCII,
0062TCSS, 0062TCII
(62" MOWER DECKS)**

Parts List

TABLE OF CONTENTS

GI862 MOWER DECK (1983)	C4
0062-T MOWER DECK (1984-1986)	C6
62" DECK DRIVE (1987-1988)	C7
62" DECK PARTS (1987-1988)	C8
0062TCSS, 0062TCII DECK DRIVE (1988-1991)	C9
0062TCSS, 0062TCII DECK PARTS (1988-1991)	C10
62TCSS, 62TCII DECK PARTS (1992 AND AFTER)	C12
62TCSS, 62TCII DECK DRIVE (1992 AND AFTER)	C14
DECALS	D1
GEAR BOX (1982-1987)	D2
GEAR BOX (1988 AND AFTER)	D4

APPLICATION CHART

62" DECKS ON CHAIN DRIVE MOWERS

DECK MODEL	YEAR USED	MOWER MODEL
GI862	1983	GI862
0062-T	1984-1986	GI600, GI800
62"	1987-1988	GI800
62TCSS	1989 AND AFTER	GI800CD

62" DECKS ON HYDRAULIC DRIVE MOWERS (DOES NOT INCLUDE LIQUID COOLED MOWER)

DECK MODEL	YEAR USED	MOWER MODEL
0062TCSS, 0062TCII	1988-1991	GI800, G2000
62TCSS, 62TCII	1992 AND AFTER	GI890, G2090, G2000



Grazer Division, Ingersoll Equipment Company
Winneconne, WI 54986

G1862 MOWER DECK ASSEMBLY

1983

G1862 MOWER DECK ASSEMBLY

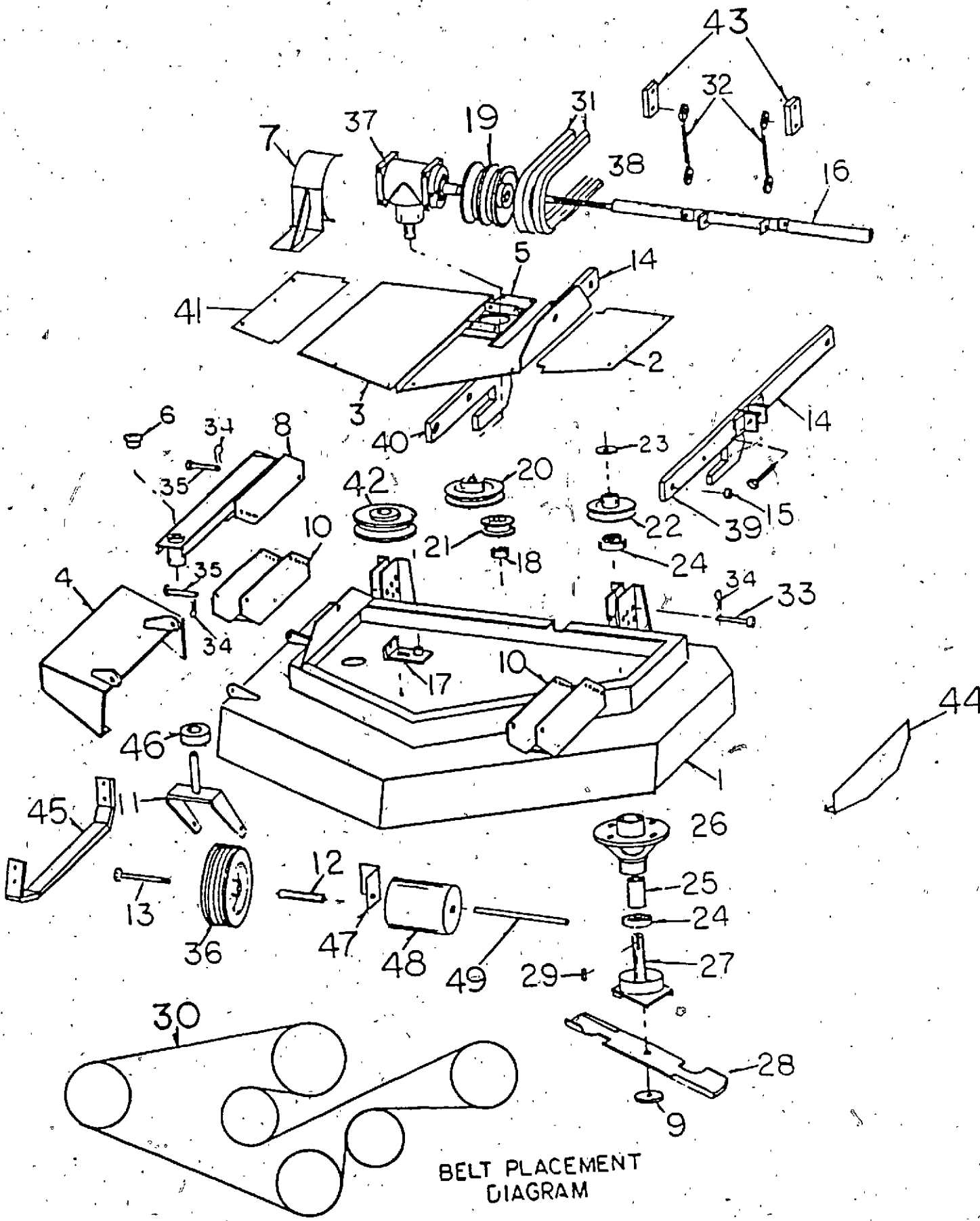

REF NO.	PART NO.	NO. REQUIRED.	DESCRIPTIONS
1.	330-0000	1	MOWER DECK
2.	330-0001	1	COVER (SMALL)
3.	330-0002	1	COVER (LARGE)
4.	330-0003	1	FOOT GUARD
5.	330-0004	1	GEAR BOX MOUNT
6.	900-3503	4	GAUGE WHEEL BEARINGS
7.	330-0006	1	BELT GUARD
8.	330-0005	2	GAGE WHEEL MOUNT
9.	900-5534	3	SPRING WASHER
10.	320-0006	2	BRACKET, GAGE WHEEL MOUNT
11.	330-0007	2	FORK GAGE WHEEL
12.	200-0017	2	AXLE
13.	-----	2	AXLE BOLT
14.	330-0024	2	DECK LIFT ARM BACK ADJUSTABLE
15.	300-0013	2	BUSHING, DECK LIFT ARM
16.	300-0014	1	CROSS BAR
17.	330-0012	1	BELT TIGHTENER
18.	330-0016	1	SPACER IDLER
19.	900-2524	1	PULLEY GEAR BOX (IN PUT)
20.	900-2510	1	PULLEY GEAR BOX (OUT PUT)
21.	900-2522	1	5° IDLER
22.	900-2512	3	PULLEY SPINDLE
23.	300-0017	3	WASHER SPINDLE
24.	900-3506	6	BEARING, SPINDLE
25.	300-0034	3	SPACER SPINDLE
26.	300-0031	3	HOUSING SPINDLE
27.	300-0032	3	SHAFT SPINDLE
28.	900-5529	3	BLADE
29.	300-0021	3	KEY SPINDLE
30.	900-3008B	1	BELT, DECK
31.	900-3009	2	BELT, DRIVE
32.	900-5518	2	CABLE DECK
33.	900-5519	2	PIN, DECK
34.	900-5520	6	HAIR PIN
35.	900-5536	4	PINS, GAGE WHEEL
36.	900-4004	2	GAGE WHEEL
37.	900-5535	1	GEAR BOX
38.	300-0022	1	CROSS BAR PIN
39.	300-0023 L.H.	1	DECK LIFT ARM FRONT ADJUSTABLE L.H.
40.	300-0024	1	DECK LIFT ARM FRONT ADJUSTABLE R.H.
41.	330-0009	1	COVER, RIGHT HAND SIDE
42.	900-2521	1	PULLEY, IDLER LARGE
43.	330-0010	2	CABLE EXTENDERS
44.	330-0008	1	SHOE LEFT HAND SIDE
45.	330-0011	1	SHOE RIGHT HAND SIDE
46.	900-5510	2	SET COLLAR
47.	300-0037	1	ROLLER BRACKET
48.	900-5559	1	RUBBER ROLLER
49.	300-0038	1	ROLLER SHAFT

62 MOWER DECK ASSEMBLY

0062-T

0062-T
62 MOWER DECK ASSEMBLY

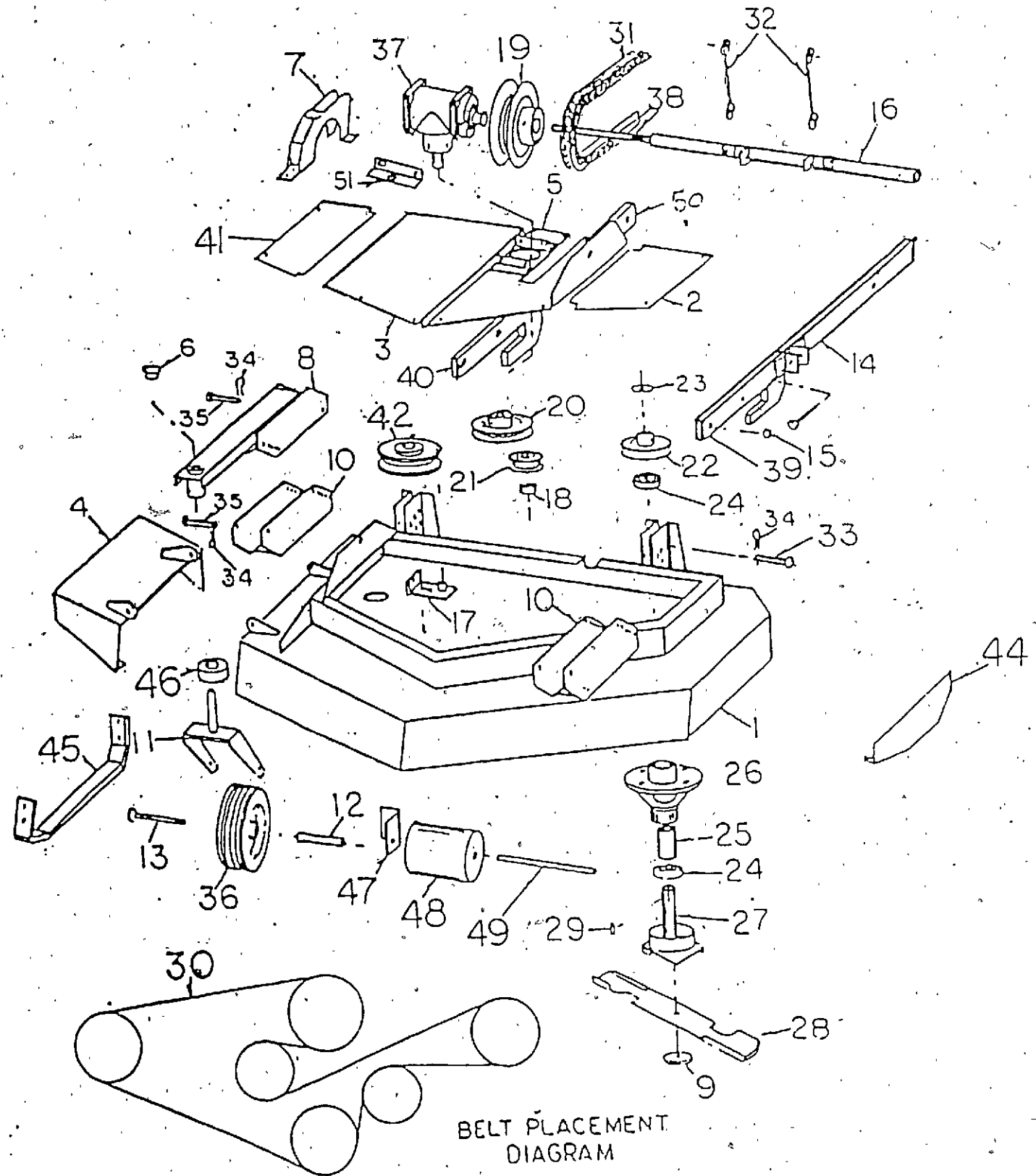

REF NO.	PART NO.	NO. REQUED.	DESCRIPTIONS
1.	330-0000	1	MOWER DECK
2.	330-0001	1	COVER (SMALL)
3.	330-0002	1	COVER (LARGE)
4.	330-0003	1	FOOT GUARD
5.	331-0004	1	GEAR BOX MOUNT
6.	900-3503	4	GAUGE WHEEL BEARINGS
7.	311-0002	1	BELT GUARD
8.	330-0005	2	GAGE WHEEL MOUNT
9.	900-5534	3	SPRING WASHER
10.	320-0006	2	BRACKET, GAGE WHEEL MOUNT
11.	330-0007	2	FORK GAGE WHEEL
12.	200-0017	2	AXLE
13.	-----	2	AXLE BOLT
14.	330-0024 L.H.	1	DECK LIFT ARM BACK ADJUSTABLE
15.	300-0013	2	BUSHING, DECK LIFT ARM
16.	300-0014	1	CROSS BAR
17.	330-0012	1	BELT TIGHTENER
18.	330-0016	1	SPACER IDLER
19.	900-2525	1	PULLEY GEAR BOX (IN PUT)
20.	900-2510	1	PULLEY GEAR BOX (OUT PUT)
21.	900-2522	1	5° IDLER
22.	900-2512	3	PULLEY SPINDLE
23.	300-0017	3	WASHER SPINDLE
24.	900-3506	6	BEARING, SPINDLE
25.	300-0034	3	SPACER SPINDLE
26.	300-0031	3	HOUSING SPINDLE
27.	300-0032	3	SHAFT SPINDLE
28.	900-5529	3	BLADE
29.	300-0021	3	KEY SPINDLE
30.	900-3008B	1	BELT, DECK
31.	900-3012	1	BELT, DRIVE
32.	900-5518	2	CABLE DECK
33.	900-5519	2	PIN, DECK
34.	900-5520	6	HAIR PIN
35.	900-5536	4	PINS, GAGE WHEEL
36.	900-4004	2	GAGE WHEEL
37.	900-5535	1	GEAR BOX
38.	300-0022	1	CROSS BAR PIN
39.	300-0023 L.H.	1	DECK LIFT ARM FRONT ADJUSTABLE L.H.
40.	300-0023 R.H.	1	DECK LIFT ARM FRONT ADJUSTABLE R.H.
41.	330-0009	1	COVER, RIGHT HAND SIDE
42.	900-2521	1	PULLEY, IDLER LARGE
44.	330-0008	1	SHOE LEFT HAND SIDE
45.	330-0011	1	SHOE RIGHT HAND SIDE
46.	900-5510	2	SET COLLAR
47.	300-0037	1	ROLLER BRACKET
48.	900-5559	1	RUBBER ROLLER
49.	300-0038	1	ROLLER SHAFT
50.	330-0024 R.H.	1	DECK LIFT ARM, BACK ADJUSTABLE
51.	310-0006	1	GEAR BOX MOUNT ANGLE

62" DECK DRIVE

REF. NO.	PART NO.	AMT. REQ'D	DESCRIPTION	REF. NO.	PART NO.	AMT. REQ'D	DESCRIPTION
1.	330-0004	1	GEAR BOX MOUNT	14.	900-2521	1	IDLER PULLEY LARGE
2.	311-0002	1	BELT GUARD	15.	900-2522	1	IDLER PULLEY SMALL
3.	310-0006	1	GEAR BOX MOUNT ANGLE	16.	900-3008B	1	DECK BELT
4.	330-0012	1	BELT TIGHTENER	17.	900-3012	1	DECK DRIVE BELT
5.	300-0031	3	SPINDLE HOUSING	18.	900-5535	1	GEAR BOX
6.	300-0034	3	SPINDLE SPACER	19.	900-6002	12	SPACER WASHER
7.	300-0032	2	SPINDLE SHAFT	20.	900-6034	1	ADJUSTMENT BOLT
8.	300-0040	1	SPINDLE SHAFT	21.	900-6053	3	5/16-24 x 3/4 HEX BOLT
9.	900-3506	6	SPINDLE BEARING	22.	300-0017	3	5/16 WASHER 10 GA
10.	900-5529	3	BLADE	23.	900-5534	3	BLADE WASHER
11.	900-2512	4	SPINDLE PULLEY	24.	900-6080	3	3/8-24 x 1 1/4 HEX BOLT
12.	900-2510	1	GEAR BOX PULLEY (OUT PUT)	25.	300-0021	6	3/16 KEY STOCK
13.	900-2525	1	GEAR BOX PULLEY (IN PUT)				

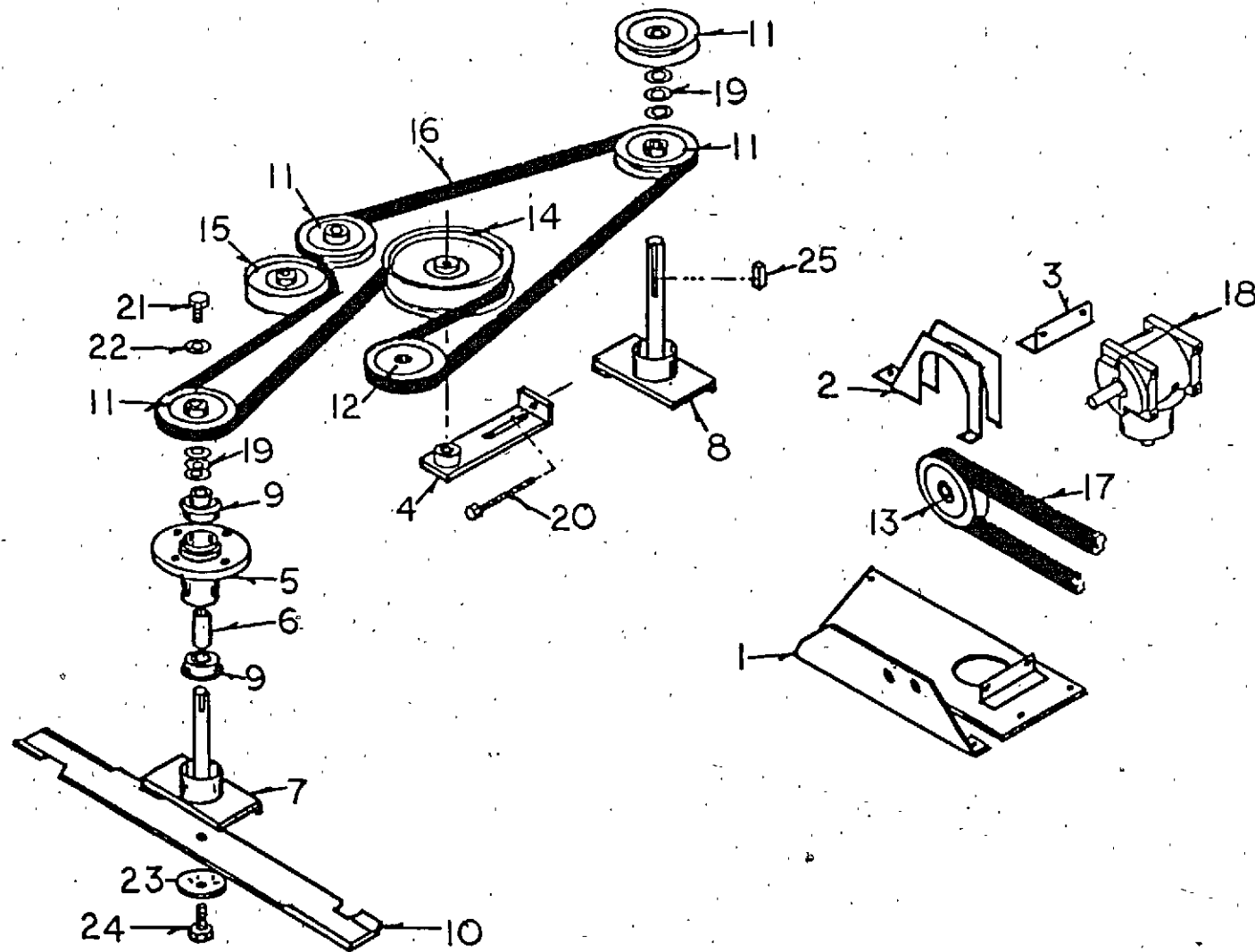

62" DECK PARTS

REF. NO.	PART NO.	AMT. REQ'D	DESCRIPTION	REF. NO.	PART NO.	AMT. REQ'D	DESCRIPTION
1.	330-0000	1	62" DECK	14.	900-4004	2	GAUGE WHEEL ASSEMBLY
2.	330-0027	1	FOOT GUARD		900-4006		11 x 4.00 x 5 TIRE
3.	330-0028	1	FOOT GUARD MOUNT		900-4005		RIM 5"
4.	330-0025	1	PULLEY COVER		900-3505		BEARING (WHEEL ASSEMBLY)
5.	330-0002	1	CENTER COVER	15.	900-6133	2	AXLE BOLT
6.	330-0001	1	LEFT HAND COVER	16.	900-6096	4	WING BOLT
7.	330-0008	1	LEFT HAND SHOE	17.	900-6092	4	HANDLE NUT
8.	900-5559	1	ANTISCALP ROLLER	18.	900-2044	1	10 AMP CIRCUIT BREAKER
9.	300-0038	1	SHAFT & BRACKET	19.	900-5510	2	1" SET COLLAR
10.	300-0044	2	GAUGE WHEEL MOUNT BRACKET	20.	900-3501	4	1" BEARING
11.	300-0043	2	GAUGE WHEEL MOUNT	21.	900-5615	1	FAS-TATCH PIN
12.	330-0007	2	FORK	22.	900-5519	2	DECK PIN
13.	200-0017	2	AXLE	23.	900-5520	2	HAIR PIN COTTER
				24.	330-0011	1	RIGHT HAND SHOE

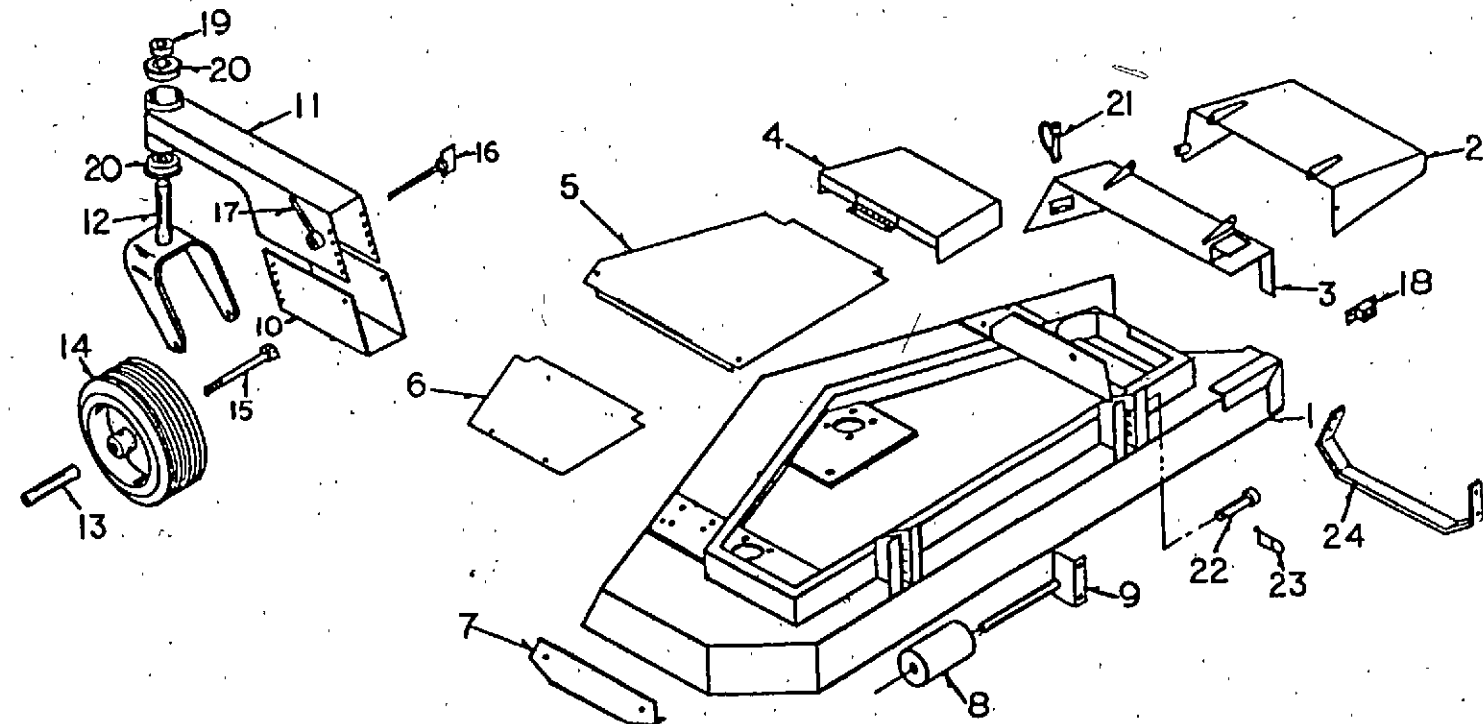

0062TCSS & 0062TCII

1988 - 1991

62" DECK PARTS

0062TCSS & 0062TCII

1988-1991

62" DECK DRIVE

REF. NO.	PART NO.	AMT. REQ'D	DESCRIPTION	REF. NO.	PART NO.	AMT. REQ'D	DESCRIPTION
1.	330-0000	1	62" DECK	14.	900-4004	2	GAUGE WHEEL ASSEMBLY
2.	330-0027	1	FOOT GUARD		900-4006		11 x 4.00 x 5 TIRE
3.	330-0028	1	FOOT GUARD MOUNT		900-4005		RIM 5"
4.	330-0025	1	PULLEY COVER		900-3505		BEARING (WHEEL ASSEMBLY)
5.	330-0002	1	CENTER COVER	15.	900-6133	2	AXLE BOLT
6.	330-0001	1	LEFT HAND COVER	16.	900-6096	4	WING BOLT
7.	330-0008	1	LEFT HAND SHOE	17.	900-6092	4	HANDLE NUT
8.	900-5559	1	ANTISCALP ROLLER	18.	900-2044	1	10 AMP CIRCUIT BREAKER
9.	300-0038	1	SHAFT & BRACKET	19.	900-5510	2	1" SET COLLAR
10.	300-0044	2	GAUGE WHEEL MOUNT BRACKET	20.	900-3501	4	1" BEARING
11.	300-0043	2	GAUGE WHEEL MOUNT	21.	900-5615	1	FAS-TATCH PIN
12.	330-0007	2	FORK	22.	900-5519	2	DECK PIN
13.	200-0017	2	AXLE	23.	900-5520	2	HAIR PIN COTTER
				24.	330-0011	1	RIGHT HAND SHOE

REF. NO.	PART NO.	AMT. REQ'D	DESCRIPTION	REF. NO.	PART NO.	AMT. REQ'D	DESCRIPTION
1.	331-0004	1	GEAR BOX MOUNT	13.	900-2543	1	GEAR BOX PULLEY (IN PUT)(2000)
2.	311-0002	1	BELT GUARD (1800)	14.	900-2521	1	IDLER PULLEY LARGE
2.	330-0030	1	BELT GUARD (2000)	15.	900-2522	1	IDLER PULLEY SMALL
3.	310-0006	1	GEAR BOX MOUNT ANGLE	16.	900-3008B	1	DECK BELT
4.	330-0012	1	BELT TIGHTENER	17.	900-3004	1	DECK DRIVE BELT (1800)
5.	300-0031	3	SPINDLE HOUSING	17.	900-3023	2	DECK DRIVE BELT (2000)
6.	300-0034	3	SPINDLE SPACER	18.	900-5535	1	GEAR BOX
7.	300-0032	2	SPINDLE SHAFT	19.	900-6002	12	SPACER WASHER
8.	300-0040	1	SPINDLE SHAFT LONG	20.	900-6034	1	ADJUSTMENT BOLT
9.	900-3506	6	SPINDLE BEARING	21.	900-6053	3	5/16-24 x 3/4 HEX BOLT
10.	900-5529	3	BLADE	22.	300-0017	3	5/16 WASHER 10 GA
11.	900-2512	4	SPINDLE PULLEY	23.	900-5534	3	BLADE WASHER
12.	900-2510	1	GEAR BOX PULLEY (OUT PUT)	24.	900-6080	3	3/8-24 x 1 1/4 HEX BOLT
13.	900-2525	1	GEAR BOX PULLEY (IN PUT)(1800)	25.	300-0021	6	3/16 KEY STOCK

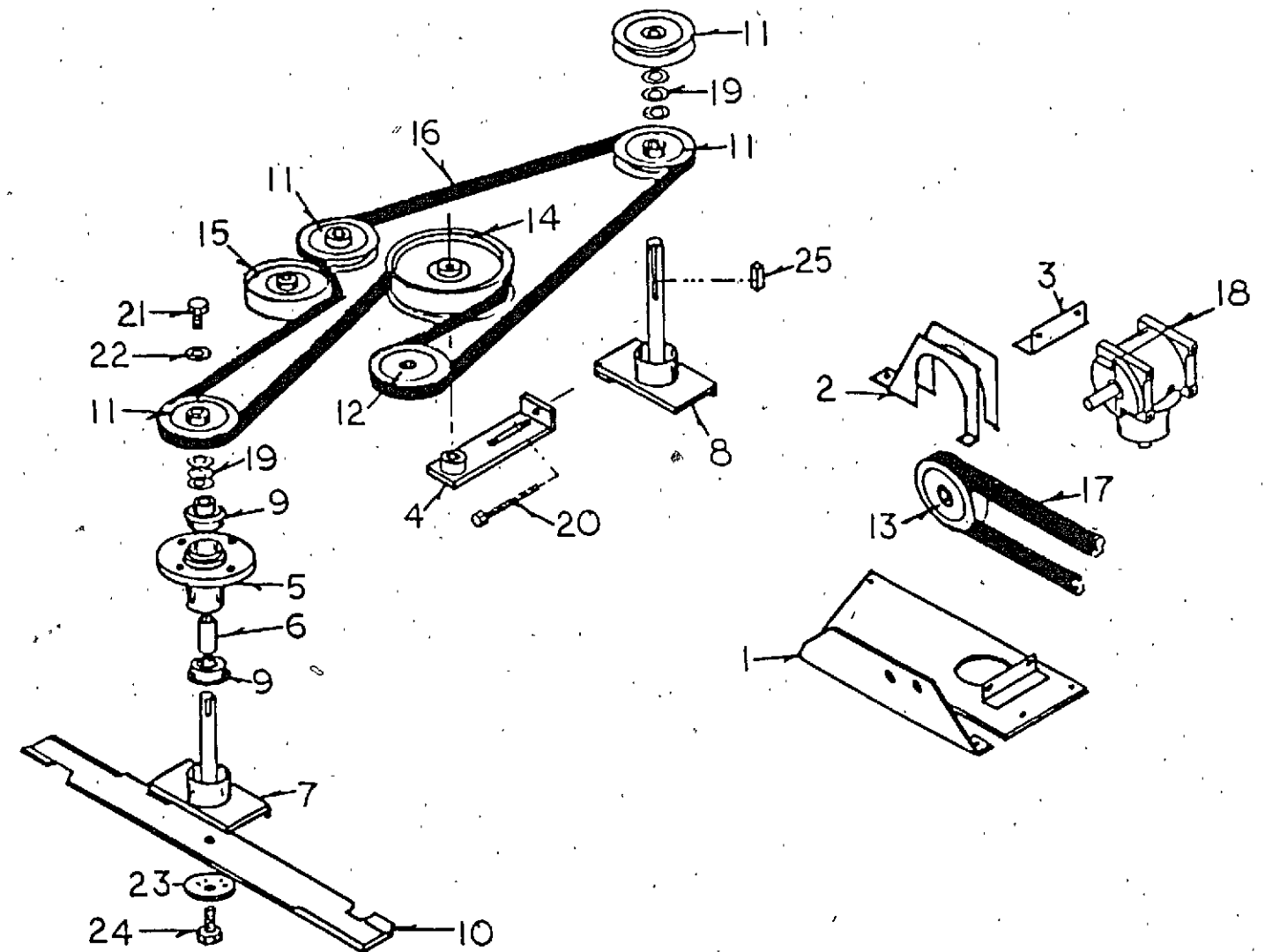
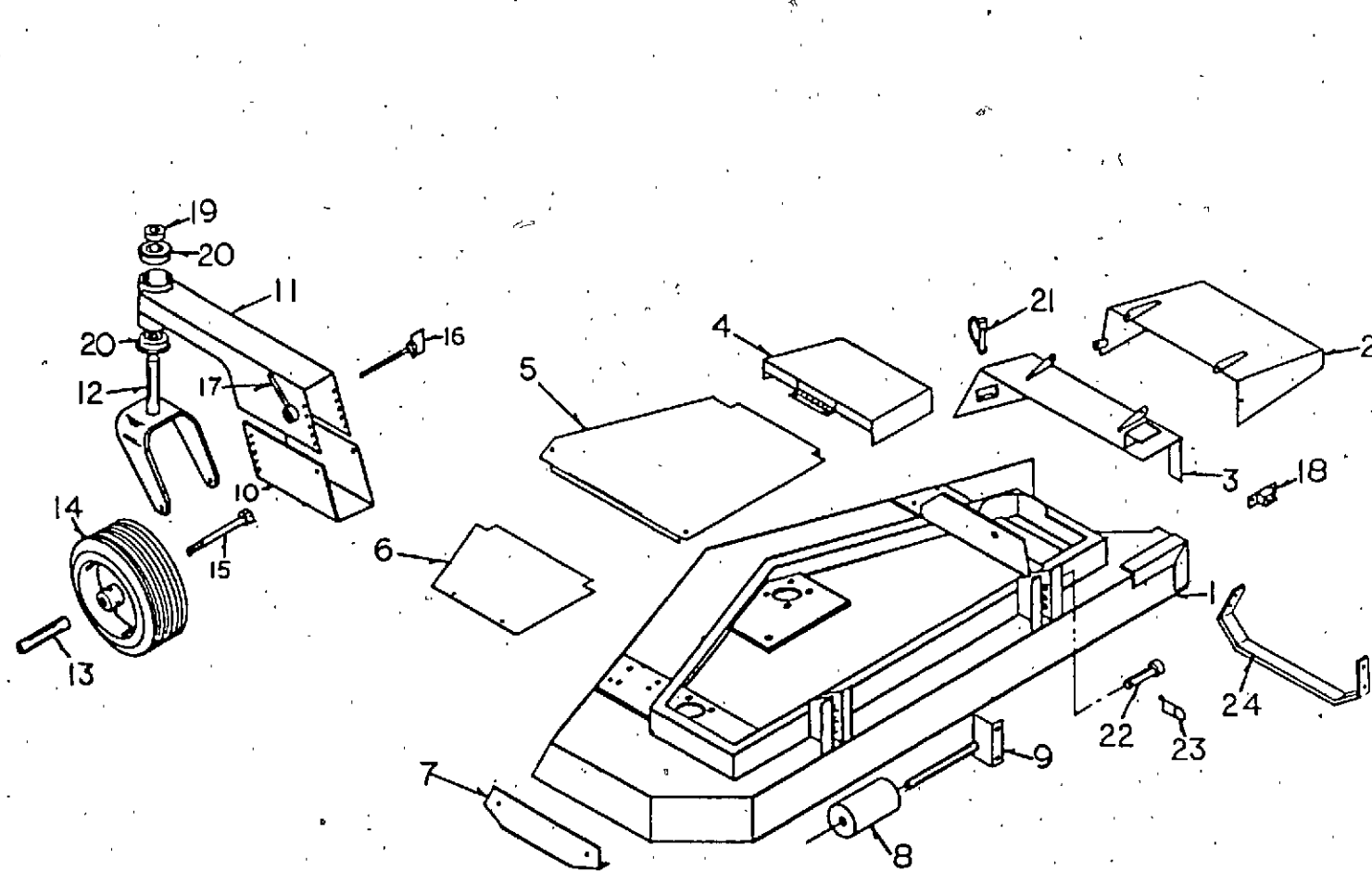

62" MOWER DECK AND ATTACHING PARTS

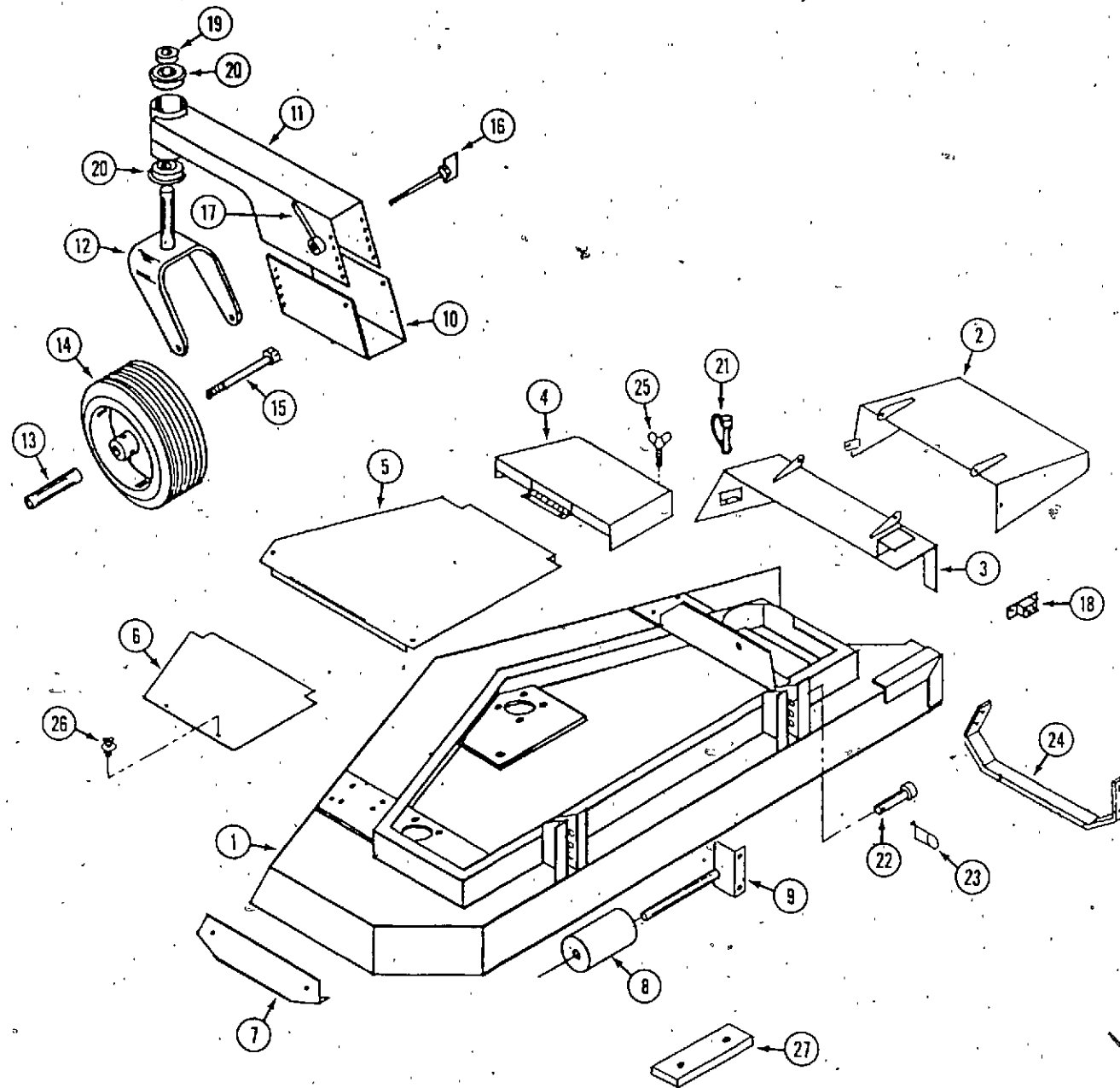

REF.	PART NO.	DESCRIPTION	REQ'D
1	C 44088	DECK - 62"	1
2	C 41396	CHUTE - foot guard	1
3	C 41400	MOUNT - foot guard	1
4	C 41392	COVER - pulley	1
5	C 41378	COVER - center	1
6	C 41373	COVER - L.H.	1
7	C 37956	SHOE - skid L.H.	1
8	C 37910	ROLLER - anti-skid	1
9	C 37911	SHAFT - roller	1
10	C 37912	BRACKET - gauge wheel mount	2
11	C 37913	MOUNT - gauge wheel	2
12	C 37914	FORK - gauge wheel	2
13	C 37915	AXLE - gauge wheel	2
14	C 37916	WHEEL - gauge	2
	C 37917	TIRE - 11 x 4.00 - 5	1
	C 37918	RIM - 5"	1
	C 44499	BEARING - wheel	2
15	113-2419	BOLT - 1/2" - 13 x 6-1/2"	2
16	C 37920	BOLT - wing	4
17	C 37921	NUT - gauge wheel handle	4
18	C 37505	BREAKER - circuit - 10 amp	1
19	C 37860	COLLAR - set 1"	2
20	C 37824	BEARING - 1"	4
21	C 37922	PIN - "fas-tatch"	1
22	C 10821	PIN - deck	2
23	C 29029	PIN - cotter, hair	2
24	C 37957	SHOE - skid R.H.	1
25	NSS	SCREW - thumb 1/4" - 20 x 1/2" (use 113-3 and 192-19)	4
26	NSS	SCREW - wing 1/4" - 20 x 1" (use 113-3)	1
27	C 37958	WEIGHT - tail, 13 lb.	3

62TCSS & 62TCII
62" MOWER DRIVE

1992 AND AFTER

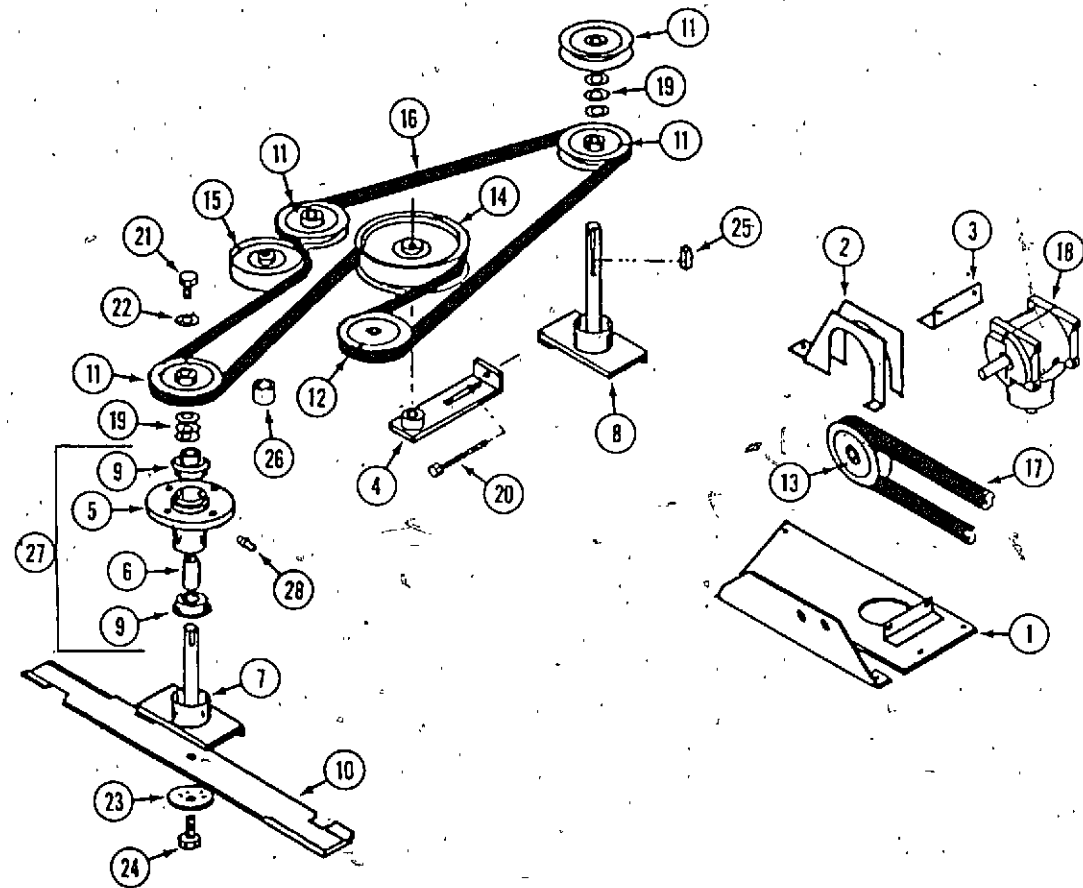

REF.	PART NO.	DESCRIPTION	REQ'D
1	C 41757	MOUNT - gear box	1
2	C 37875	GUARD - belt	1
3	C 37877	ANGLE - gear box mount	1
4	C 37929	TIGHTENER - belt	1
5	C 37945	HOUSING - spindle	3
6	C 37946	SPACER - spindle	3
7	C 44132 **	SHAFT - spindle, short	2
8	C 44134 **	SHAFT - spindle, long	1
9	C 42786	BEARING - spindle	6
10	C 44138 **	BLADE	3
11	C 37950	PULLEY - spindle	4
12	C 37932	PULLEY - gear box output	1
13	C 37892	PULLEY - gear box input	1
14	C 37933	PULLEY - idler, large	1
15	C 37934	PULLEY - idler, small	1
16	C 38929	BELT - deck	1
17	C 37894	BELT - drive (1800SS, 1800KSS, 1890, 1890K)	1
18	C 37898	GEAR BOX - angle drive (see page 83 for service) (Curtis model)	1
18	C 42775	GEAR BOX - angle drive (see page 83 for service) (Superior model)	1
19	C 37888	WASHER - spacer	12
20	C 37901	BOLT - 1/4" - 20 x 4"	1
21	C 39386	BOLT - 5/16" - 24 x 3/4"	3
22	C 37900	WASHER - 5/16", 10 ga	3
24	113- 268	BOLT - 3/8" - 16 x 1" (also requires 131-1216 locknut)	6
25	C 29581	KEY - 3/16" x 3/16" x 1"	6
26	C 37937	SPACER - idler pulley	1
27	C 37951	HOUSING ASSEMBLY - spindle (includes ref. 5, 6, 9)	3
28	219- 20	FITTING - grease 1/4" - 28	3

for model 62 TCSS
*use before S/N 013306063
**use S/N 013306063 and after

for model 62TCII
*use before S/N 013307056
**use S/N 013307056 and after

DECALS (Deck)

REF.	PART NO.	DESCRIPTION	REQ'D
1	C 37491	DECAL - "Whirling Blades"	1
2	C 37492	DECAL - "Caution" discharge chute	1
3	C 37493	DECAL - "Caution" grass chute	1
4	C 37494	DECAL - "Danger"	1

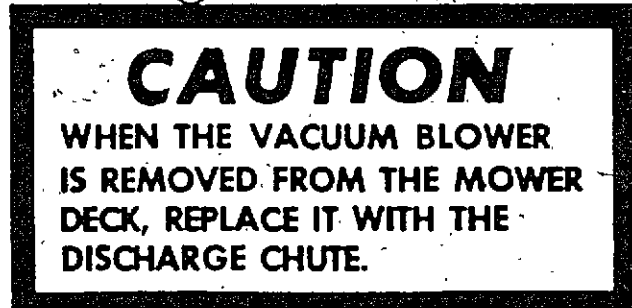

GEAR BOX

1982-1987

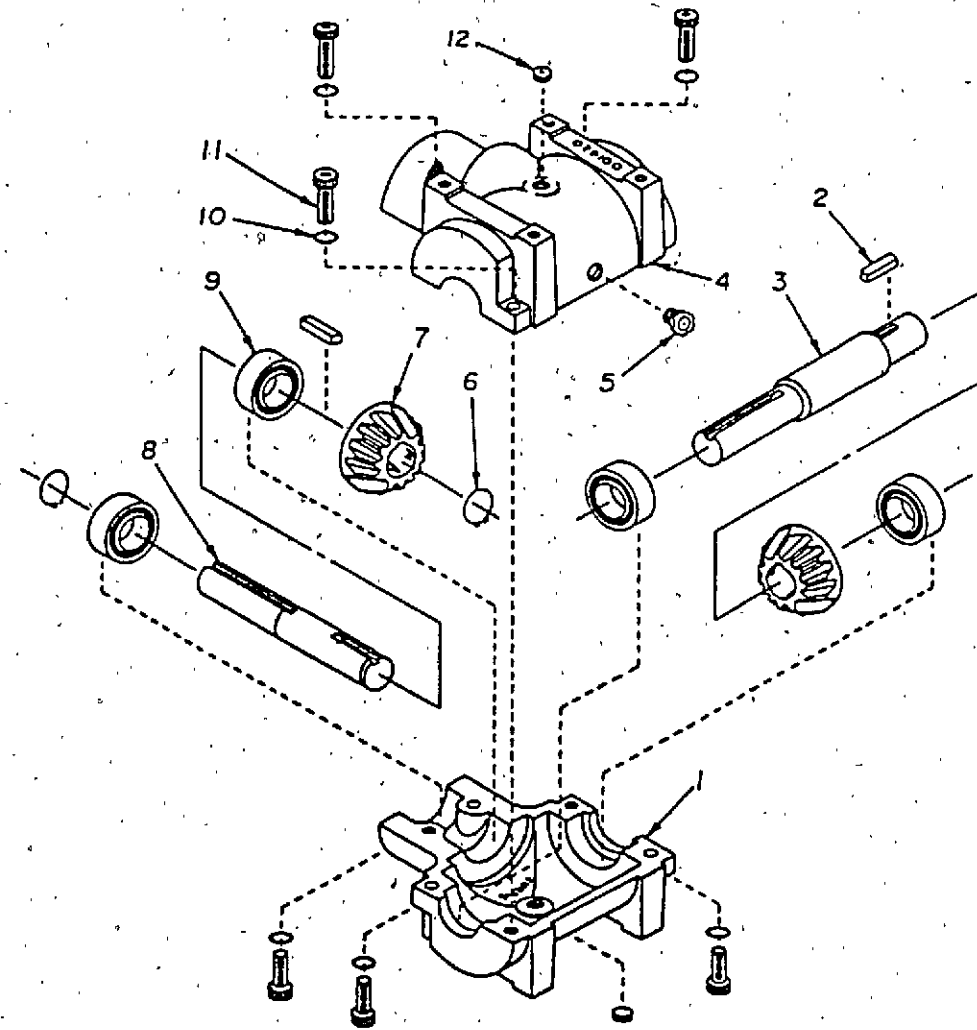

REF. NO.	PART NO.	DESCRIPTIONS
1.	900-7000	HOUSING HALF
2.	900-7001	KEY
3.	900-7002	SHAFT
4.	900-7003	HOUSING HALF
5.	900-7004	RELIEF VALVE
6.	900-7005	RETAINING RING
7.	900-7006	GEAR
8.	900-7007	SHAFT
9.	900-7008	BALL BEARING
10.	900-7009	LOCKWASHER
11.	900-7010	ALLEN HEAD BOLT
12.	900-7011	PIPE PLUG

GEAR BOX

1988 AND AFTER

(Curtis)

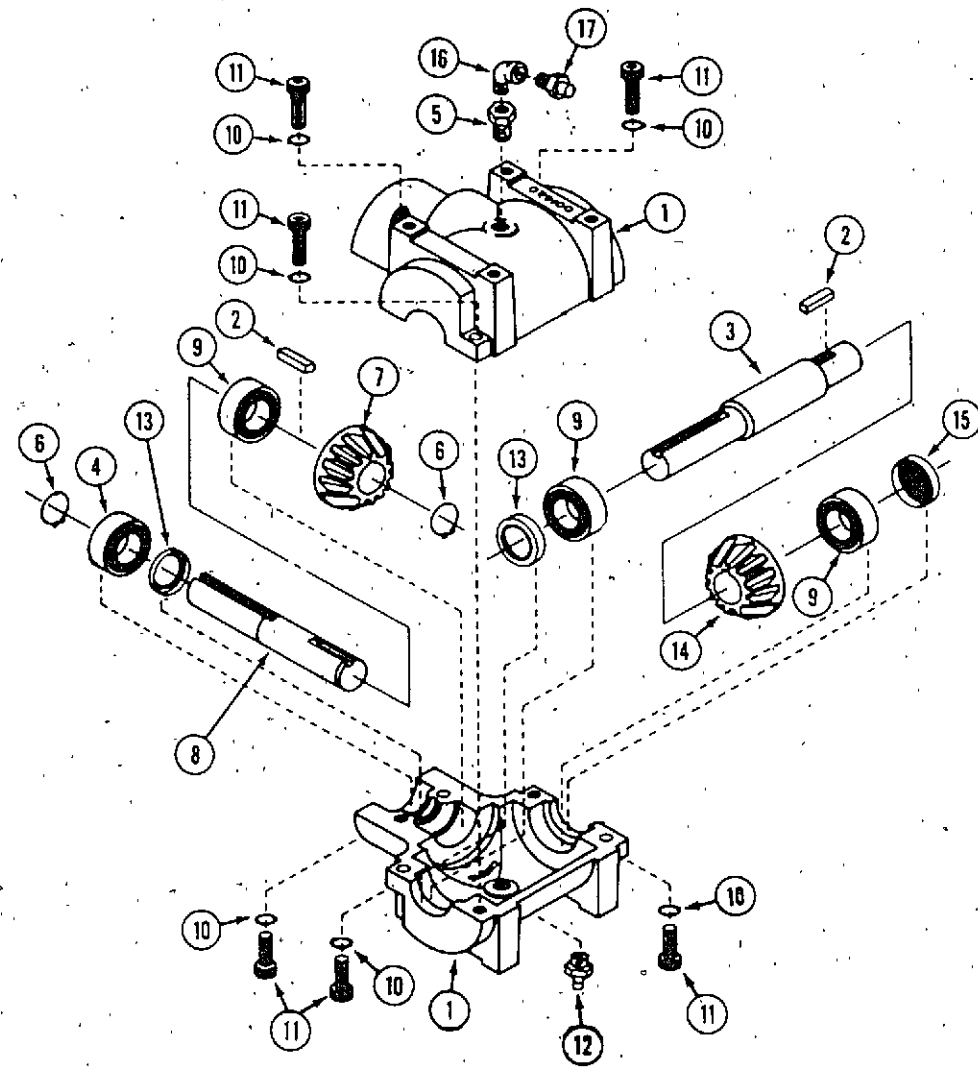

REF.	PART NO.	DESCRIPTION	REQ'D
	C 37898	GEAR BOX	1
1	C 37959	HOUSING - half	2
2	C 29581	KEY - 3/16" x 3/16" x 1"	2
3	C 37960	SHAFT - input	1
4	C 37961	BEARING - ball	1
5	C 37962	BUSHING - pipe 1/4" x 1/8"	1
6	C 37963	RING - retaining	2
7	C 37964	GEAR - output shaft	1
8	C 37965	SHAFT - output	1
9	C 37966	BEARING - ball	3
10	C 37967	LOCKWASHER	6
11	C 37968	CAP SCREW - allen head	6
12	C 37974	FITTING - grease 1/4" NPT	1
13	C 37969	SEAL - shaft	2
14	C 37970	GEAR - input shaft	1
15	C 37971	PLUG - expansion	1
16	C 37541	ELBOW - street 1/8" x 90°	1
17	C 37973	VALVE - relief	1
	C 37975	GREASE - synthetic, cartridge	1

GEAR BOX

(Superior)

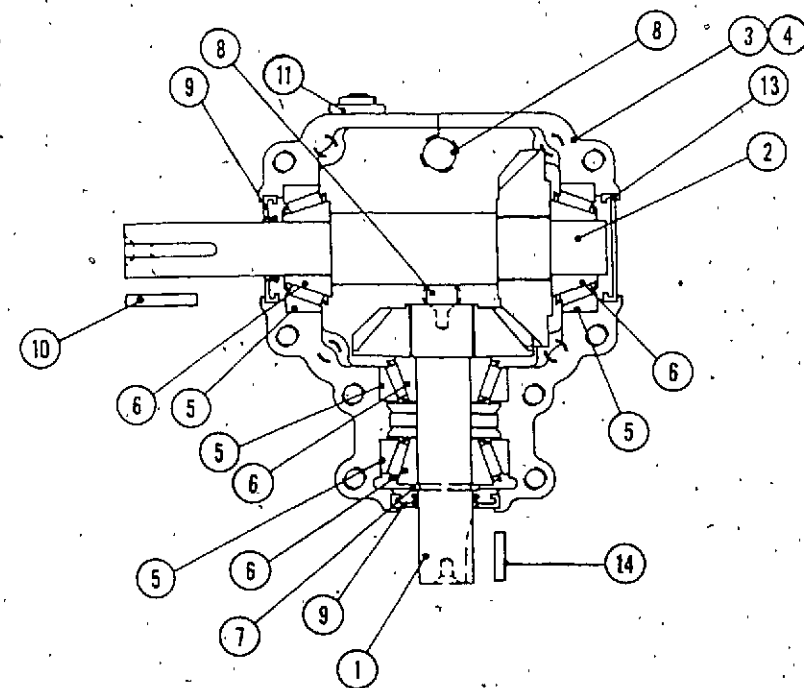

1	C 42924	SHAFT - pinion, with gear	1
2	C 42923	SHAFT - cross, with gear	1
3	C 42917	HOUSING - with tapped holes	1
4	C 42927	HOUSING - with thru holes (not shown)	1
5	C 42918	CUP - bearing	4
6	C 42921	CONE - bearing	4
7	C 42919	RING - retaining	1
8	C 42920	PLUG - pipe 1/4"	3
9	C 42922	SEAL - shaft	2
10	C 29581	KEY - 3/16" x 1" input shaft	1
11	C 42928	PIPE - vent	1
12	C 42926	BOLT - 5/16" x 1" socket head (not shown)	8
13	C 42925	CAP - end	1
14	C 28215	KEY - 3/16" x 5/8" output shaft	1

GRAZER

GROUNDS MOWERS

Models

**MK52-1B, MK52-2B,
MK62-1B, MK62-2B
MULCHING KITS**

Parts List

INGERSOLL
Ingersoll Equipment Co., Inc.

GRAZER

Grazer Division, Ingersoll Equipment Company
Winneconne, WI 54986

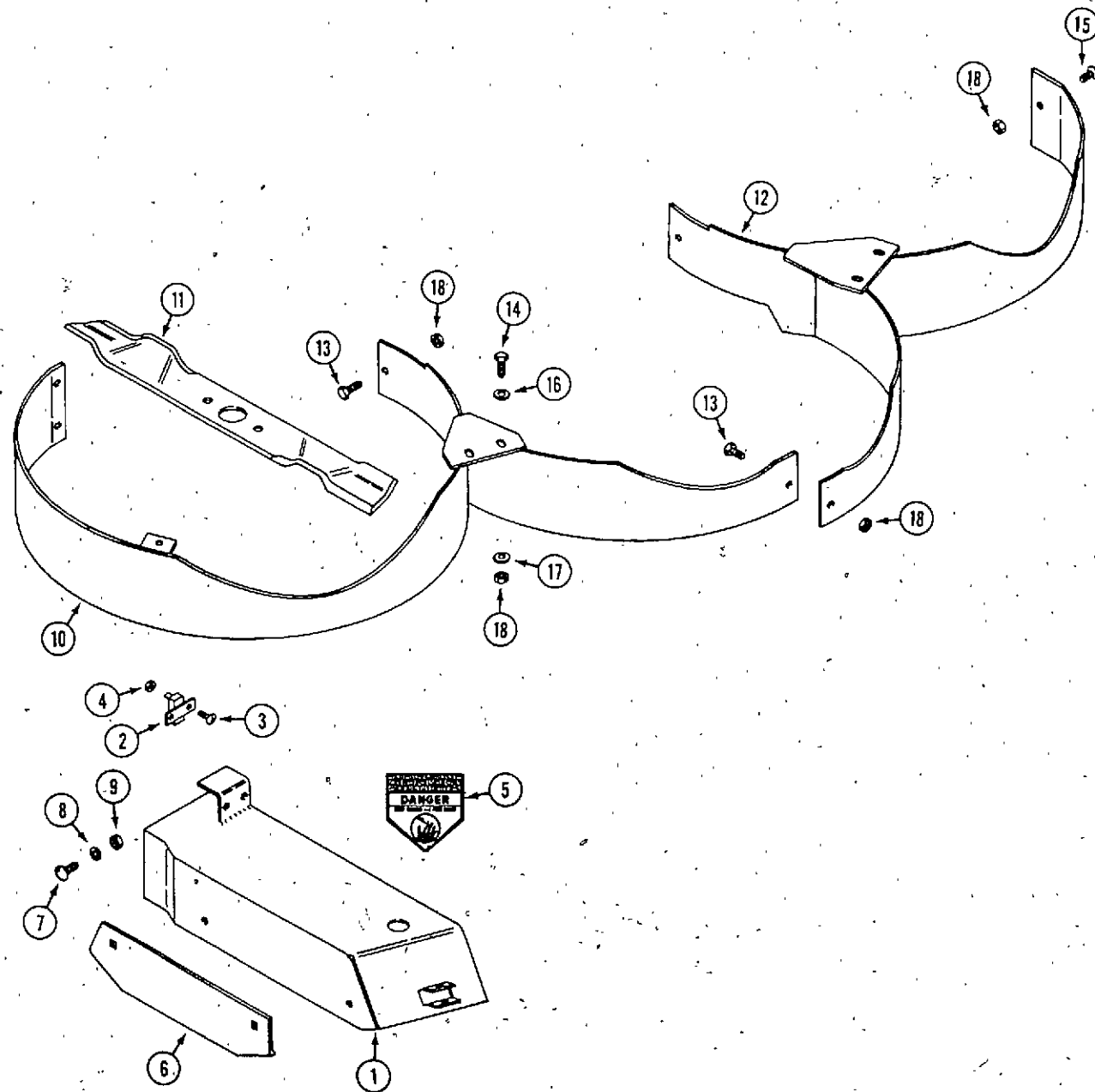

MULCHING KITS
 (MK52-2B) (MK52-1B) (MK62-2B) (MK62-1B)

REF.	PART NO.	DESCRIPTION	REQ'D
1	C 45238	CAP - end (MK52-2B) (MK52-1B)	1
.1	C 45512	CAP - end (MK62-2B) (MK62-1B) shown	1
2	C 37505	BREAKER - 10 amp	1
3	182- 528	SCREW - #10 - 32 x 1/2"	2
4	193- 1000	NUT - #10 - 32 lock	2
5	C 37494	DECAL - "Danger"	1
6	C 37956	SHOE - skid	1
7	111- 132	BOLT - 5/16" - 18 x 3/4" carriage	2
8	192- 20	WASHER - lock 5/16"	2
9	129- 102	NUT - 5/16" - 18	2
10	C 45240	BAFFLE - R.H. (MK52-2B) (MK52-1B)	1
10	C 45516	BAFFLE - R.H. (MK62-2B) (MK62-1B) shown	1
11	C 45248	BLADE - MK52-2B (18")	3
11	C 45901	BLADE - MK52-1B (18")	3
11	C 45511	BLADE - MK62-2B (21.5") shown	3
11	C 46050	BLADE - MK62-1B (21.5")	3
12	C 45244	BAFFLE - L.H. (MK52-2B) (MK52-1B)	1
12	C 45519	BAFFLE - L.H. (MK62-2B) (MK62-1B) shown	1
13	113- 102	BOLT - 5/16" - 18 x 3/4"	6
14	113- 103	BOLT - 5/16" - 18 x 1"	4
15	C 42056	SCREW - 5/16" x 18 x 5/8"	1
16	195- 521	WASHER - 5/16" x 5/8"	7
17	195- 103	WASHER - 3/8" x 7/8"	4
18	131- 69	NUT - 5/16" - 18 lock	11