



GROUNDS MOWERS

Models

**G1142, 0042-T11
42" MOWER DECK
(as used on 11hp mowers)**

Parts List

TABLE OF CONTENTS

G1142 DECK (1981)	A4
G1142 DECK (1982)	A6
G1142 DECK (1983)	A8
0042-T-11 DECK (1985-1986)	A10
DECALS	A11
GEAR BOX	A12

APPLICATION CHART

DECK MODEL	YEAR USED	MOWER MODEL
G1142	1981-1983	G1142
0042-T-11	1985-1986	G1100



Grazer Division, Ingersoll Equipment Company
Winneconne, WI 54986

G1142 MOWER DECK ASSEMBLY

REF NO.	PART NO.	NO. REQED.	DESCRIPTIONS
1.	300-0000	1	MOWER DECK
2.	300-0001	1	COVER (SMALL)
3.	300-0002	1	COVER (LARGE)
4.	300-0003	1	FOOT GUARD
5.	300-0004	1	GEAR BOX MOUNT
6.	300-0005	1	DECK MOUNT
7.	300-0006	1	BELT GUARD
8.	300-0007	2	GAGE WHEEL MOUNT
10.	300-0009	2	BRACKET, GAGE WHEEL MOUNT
11.	300-0010	2	FORK, GAGE WHEEL
12.	300-0011	2	AXLE, GAGE WHEEL
13.	-----	2	GAGE WHEEL BOLT
14.	300-0012	2	DECK LIFT ARM
15.	300-0013	2	BUSHING, DECK LIFT ARM
16.	300-0014	1	CROSSBAR
17.	300-0015	1	BELT TIGHTENER
18.	300-0016	1	SPACER, IDLER
19.	900-2504	1	PULLEY, GEAR BOX (IN-PUT)
20.	900-2505	1	PULLEY, GEAR BOX (OUT-PUT)
21.	900-2501	2	PULLEY, IDLER
22.	900-2506	3	PULLEY, SPINDLE
23.	300-0017	3	WASHER, SPINDLE
24.	900-3504	6	BEARING SPINDLE
25.	300-0018	3	SPACER SPINDLE
26.	300-0019	3	HOUSING SPINDLE
27.	300-0020	3	SHAFT SPINDLE
28.	900-5517	3	BLADE
29.	300-0021	3	KEY SPINDLE
30.	900-3001	1	BELT, DECK
31.	900-3002	1	BELT, DRIVE
32.	900-5518	2	CABLE, DECK
33.	900-5519	2	PINS, DECK
34.	900-5520	6	HAIR PIN
35.	900-5521	4	PINS, GAGE WHEEL
36.	900-4007	2	GAGE WHEEL
37.	900-5526	1	GEAR BOX
38.	300-0022	1	CROSS BAR PIN

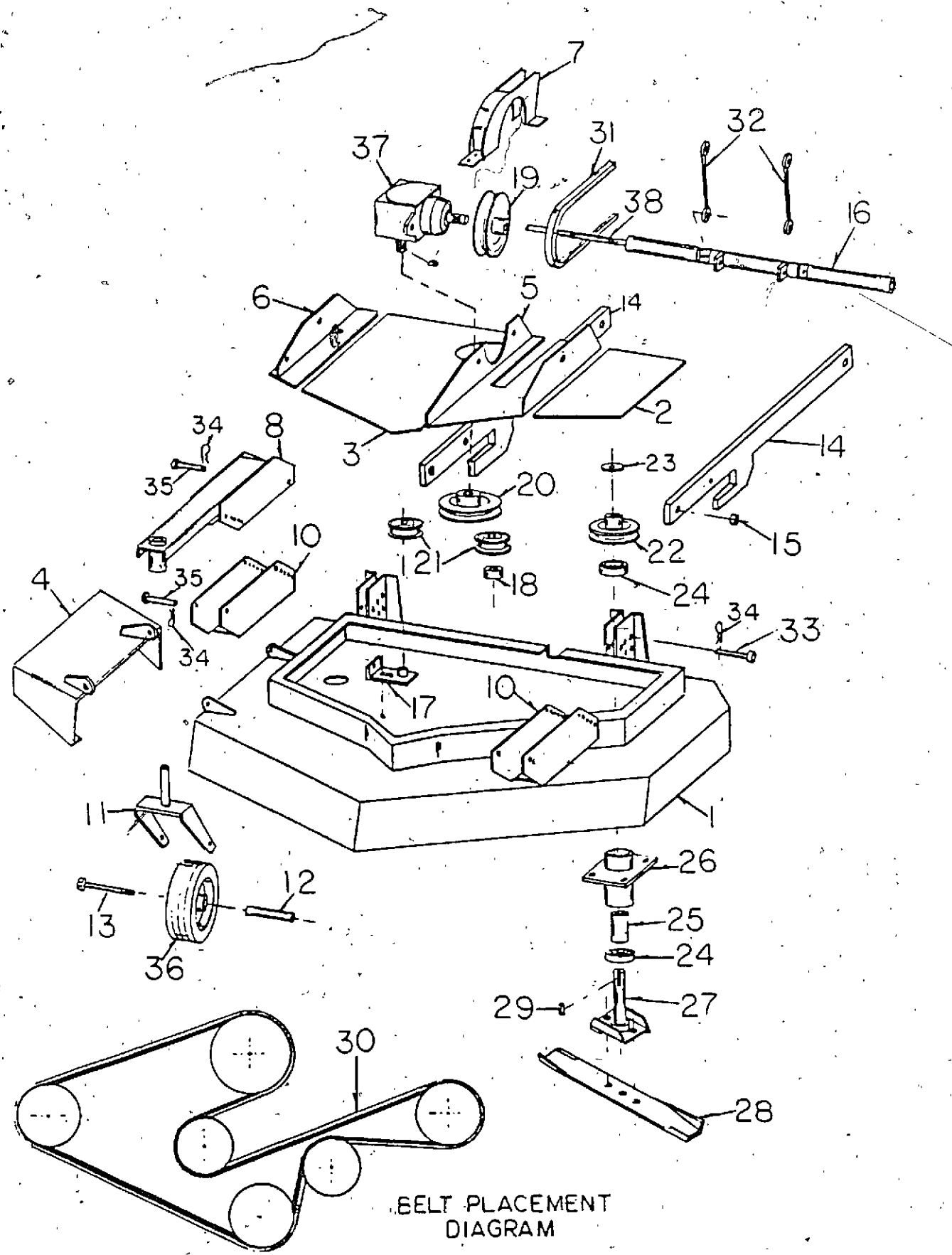

BELT PLACEMENT DIAGRAM

G1142 MOWER DECK ASSEMBLY

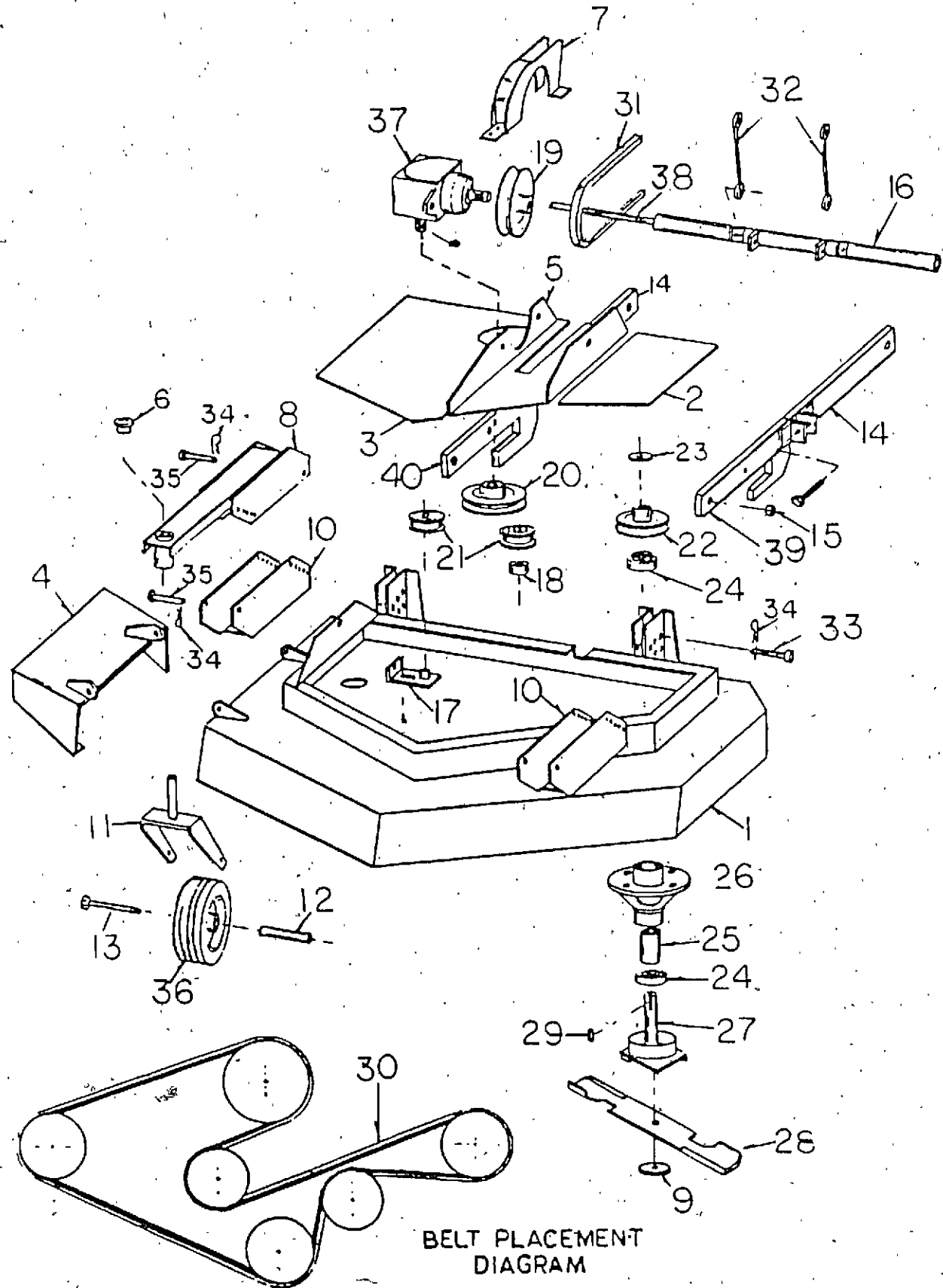

REF. NO.	PART NO.	NO. REQD.	DESCRIPTIONS
1.	300-0000	1	MOWER DECK
2.	300-0001	1	COVER (SMALL)
3.	300-0028	1	COVER (LARGE)
4.	300-0035	1	FOOT GUARD
5.	300-0004	1	GEAR BOX MOUNT
6.	900-3507	4	GAGE WHEEL BUSHING
7.	300-0036	1	BELT GUARD
8.	300-0007	2	GAGE WHEEL MOUNT
9.	900-5534	3	SPRING WASHER
10.	300-0009	2	BRACKET, GAGE WHEEL MOUNT
11.	300-0010	2	FORK, GAGE WHEEL
12.	300-0011	2	AXLE, GAGE WHEEL
13.	-----	2	GAGE WHEEL BOLT
14.	300-0024	2	DECK LIFT ARM BACK ADJUSTABLE
15.	300-0013	2	BUSHING, DECK LIFT ARM
16.	300-0014	1	CROSSBAR
17.	300-0015	1	BELT TIGHTENER
18.	300-0016	1	SPACER, IDLER
19.	900-2506	1	PULLEY, GEAR BOX (IN-PUT)
20.	900-2505	1	PULLEY, GEAR BOX (OUT-PUT)
21.	900-2508	2	PULLEY, IDLER
22.	900-2507	3	PULLEY, SPINDLE
23.	300-0017	3	WASHER, SPINDLE
24.	900-3506	6	BEARING SPINDLE
25.	300-0027	3	SPACER SPINDLE
26.	300-0025	3	HOUSING SPINDLE
27.	300-0026	3	SHAFT SPINDLE
28.	900-5531	3	BLADE
29.	300-0021	3	KEY SPINDLE
30.	900-3003	1	BELT, DECK
31.	900-3002	1	BELT, DRIVE
32.	900-5518	2	CABLE, DECK
33.	900-5519	2	PINS, DECK
34.	900-5520	6	HAIR PIN
35.	900-5521	4	PINS, GAGE WHEEL
36.	900-4007	2	GAGE WHEEL
37.	900-5526	1	GEAR BOX
38.	300-0022	1	CROSS BAR PIN
39.	300-0023 L.H.	1	DECK LIFT ARM FRONT ADJUSTABLE L.H.
40.	300-0023 R.H.	1	DECK LIFT ARM FRONT ADJUSTABLE R.H.

G1142 MOWER DECK ASSEMBLY

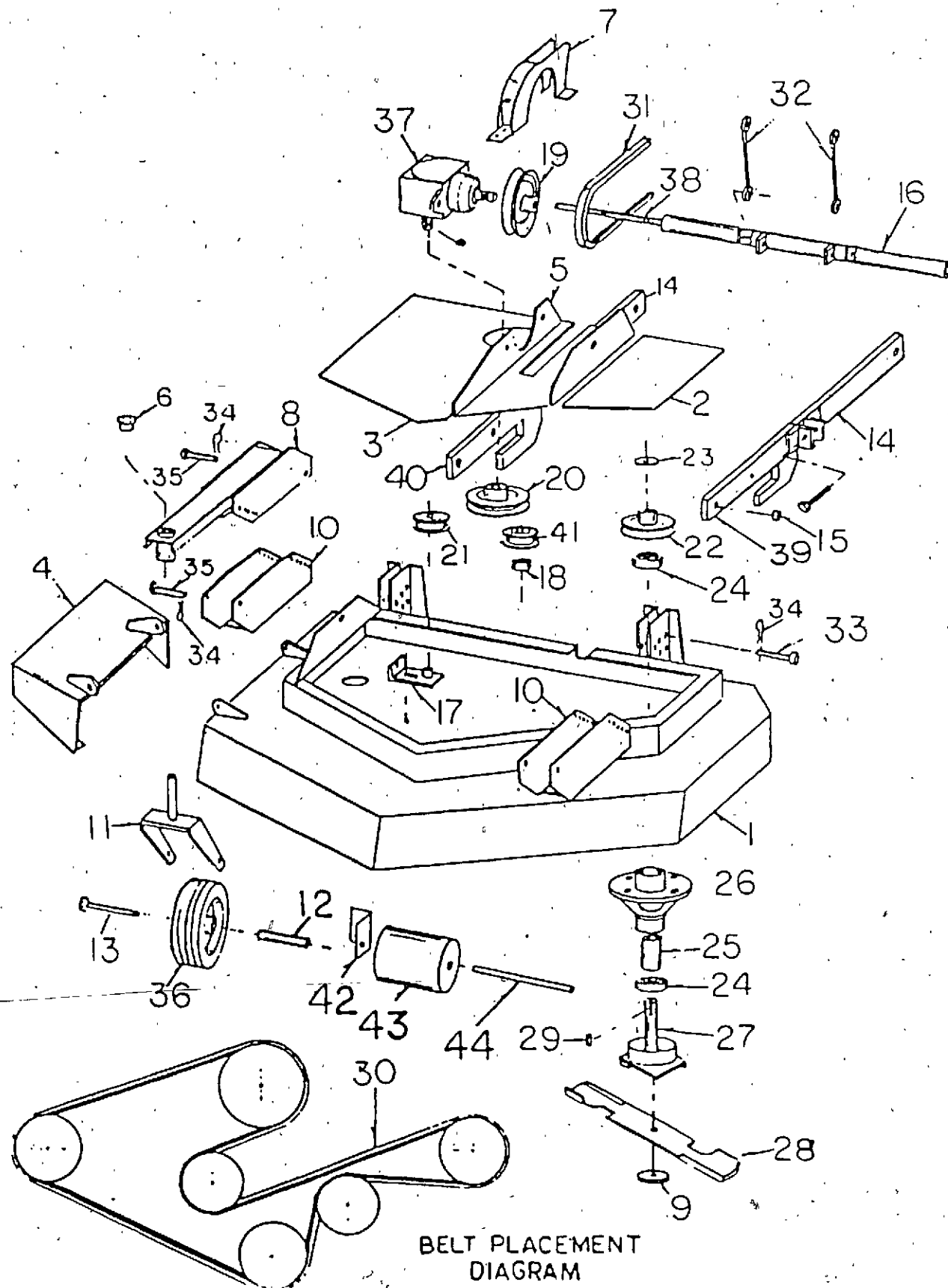

REF. NO.	PART NO.	NO. REQUIRED.	DESCRIPTIONS
1.	300-0000	1	MOWER DECK
2.	300-0001	1	COVER (SMALL)
3.	300-0028	1	COVER (LARGE)
4.	300-0035	1	FOOT GUARD
5.	300-0004	1	GEAR BOX MOUNT
6.	900-3507	4	GAGE WHEEL BUSHING
7.	300-0036	1	BELT GUARD
8.	300-0007	2	GAGE WHEEL MOUNT
9.	900-5534	3	SPRING WASHER
10.	300-0009	2	BRACKET, GAGE WHEEL MOUNT
11.	300-0010	2	FORK, GAGE WHEEL
12.	300-0011	2	AXLE, GAGE WHEEL
13.	-----	2	GAGE WHEEL BOLT
14.	300-0024	2	DECK LIFT ARM BACK ADJUSTABLE
15.	300-0013	2	BUSHING; DECK LIFT ARM
16.	300-0014	1	CROSSBAR
17.	300-0015	1	BELT TIGHTENER
18.	300-0016	1	SPACER, IDLER
19.	900-2505	1	PULLEY, GEAR BOX (IN-PUT)
20.	900-2505	1	PULLEY, GEAR BOX (OUT-PUT)
21.	900-2518	1	PULLEY, IDLER TIGHTENER
22.	900-2507	3	PULLEY, SPINDLE
23.	300-0017	3	WASHER, SPINDLE
24.	900-3506	6	BEARING, SPINDLE
25.	300-0027	3	SPACER, SPINDLE
26.	300-0025	3	HOUSING, SPINDLE
27.	300-0026	3	SHAFT, SPINDLE
28.	900-5531	3	BLADE
29.	300-0021	3	KEY, SPINDLE
30.	900-3003	1	DECK BELT (EARLY 83 MODELS)
30.	900-3003A	1	DECK BELT
31.	900-3002	1	DRIVE BELT
32.	900-5518	2	CABLE, DECK
33.	900-5519	2	PINS, DECK
34.	900-5520	6	HAIR PINS
35.	900-5521	4	PINS, GAGE WHEEL
36.	900-4007	2	GAGE WHEEL
37.	900-5526	1	GEAR BOX
38.	300-0022	1	CROSS BAR PIN
39.	300-0023L.H.	1	DECK LIFT ARM FRONT ADJUSTABLE L.H.
40.	300-0023R.H.	1	DECK LIFT ARM FRONT ADJUSTABLE R.H.
41.	900-2508B	1	IDLER PULLEY
42.	300-0037	1	ROLLER BRACKET
43.	900-5559	1	RUBBER ROLLER
44.	300-0038	1	ROLLER SHAFT

42" MOWER DECK

0042-T-11

1985 & 1986

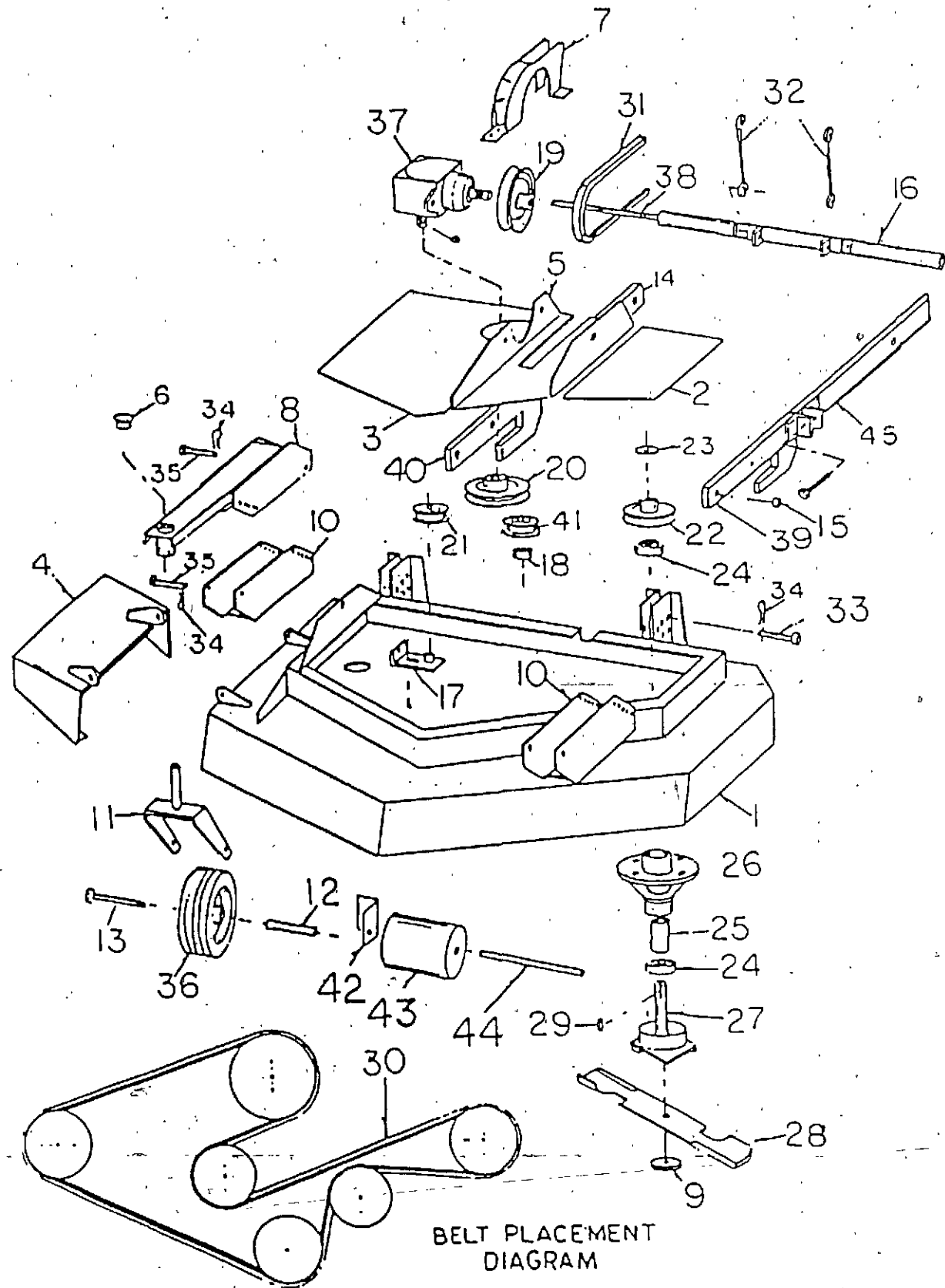

42" MOWER DECK

0042-T-11

REF. NO.	PART NO.	NO. REQUED.	DESCRIPTIONS
1.	300-0000	1	MOWER DECK
2.	300-0001	1	COVER (SMALL)
3.	300-0028	1	COVER (LARGE)
4.	300-0035	1	FOOT GUARD
5.	301-0004	1	GEAR BOX MOUNT
6.	900-3507	4	GAGE WHEEL BUSHING
7.	300-0036	1	BELT GUARD
8.	300-0007	2	GAGE WHEEL MOUNT
9.	900-5534	3	SPRING WASHER
10.	300-0009	2	BRACKET, GAGE WHEEL MOUNT
11.	300-0010	2	FORK, GAGE WHEEL
12.	300-0011	2	AXLE, GAGE WHEEL
13.	-----	2	GAGE WHEEL BOLT
14.	301-0024	1	DECK LIFT ARM BACK ADJUSTABLE
15.	300-0013	2	BUSHING, DECK LIFT ARM
16.	300-0014	1	CROSSBAR
17.	300-0015	1	BELT TIGHTNER
18.	300-0016	1	SPACER, IDLER
19.	900-2525	1	PULLEY, GEAR BOX (IN-PUT)
20.	900-2505	1	PULLEY, GEAR BOX (OUT-PUT)
21.	900-2518	1	PULLEY, IDLER TIGHTENER
22.	900-2507	3	PULLEY, SPINDLE
23.	300-0017	3	WASHER, SPINDLE
24.	900-3506	6	BEARING, SPINDLE
25.	300-0027	3	SPACER, SPINDLE
26.	300-0025	3	HOUSING, SPINDLE
27.	300-0026	3	SHAFT, SPINDLE
28.	900-5531	3	BLADE
29.	300-0021	3	KEY, SPINDLE
30.	900-3003A	1	DECK BELT
31.	900-3004	1	DRIVE BELT
32.	900-5518	2	CABLE, DECK
33.	900-5519	2	PINS, DECK
34.	900-5520	6	HAIR PINS
35.	900-5521	4	PINS, GAGE WHEEL
36.	900-4007	2	GAGE WHEEL
37.	900-5526	1	GEAR BOX
38.	300-0022	1	CROSS BAR PIN
39.	300-0023L.H.	1	DECK LIFT ARM FRONT ADJUSTABLE L.H.
40.	300-0023R.H.	1	DECK LIFT ARM FRONT ADJUSTABLE R.H.
41.	900-2508B	1	IDLER PULLEY
42.	300-0037	1	ROLLAR BRACKET
43.	900-5559	1	RUBBER ROLLAR
44.	300-0038	1	ROLLAR SHAFT
45.	301-0024L.H.	1	DECK LIFT ARM BACK ADJUSTABL

DECALS (Deck)

REF.	PART NO.	DESCRIPTION	REQ'D
1	C 37491	DECAL - "Whirling Blades"	1
2	C 37492	DECAL - "Caution" discharge chute	1
3	C 37493	DECAL - "Caution" grass chute	1
4	C 37494	DECAL - "Danger"	1

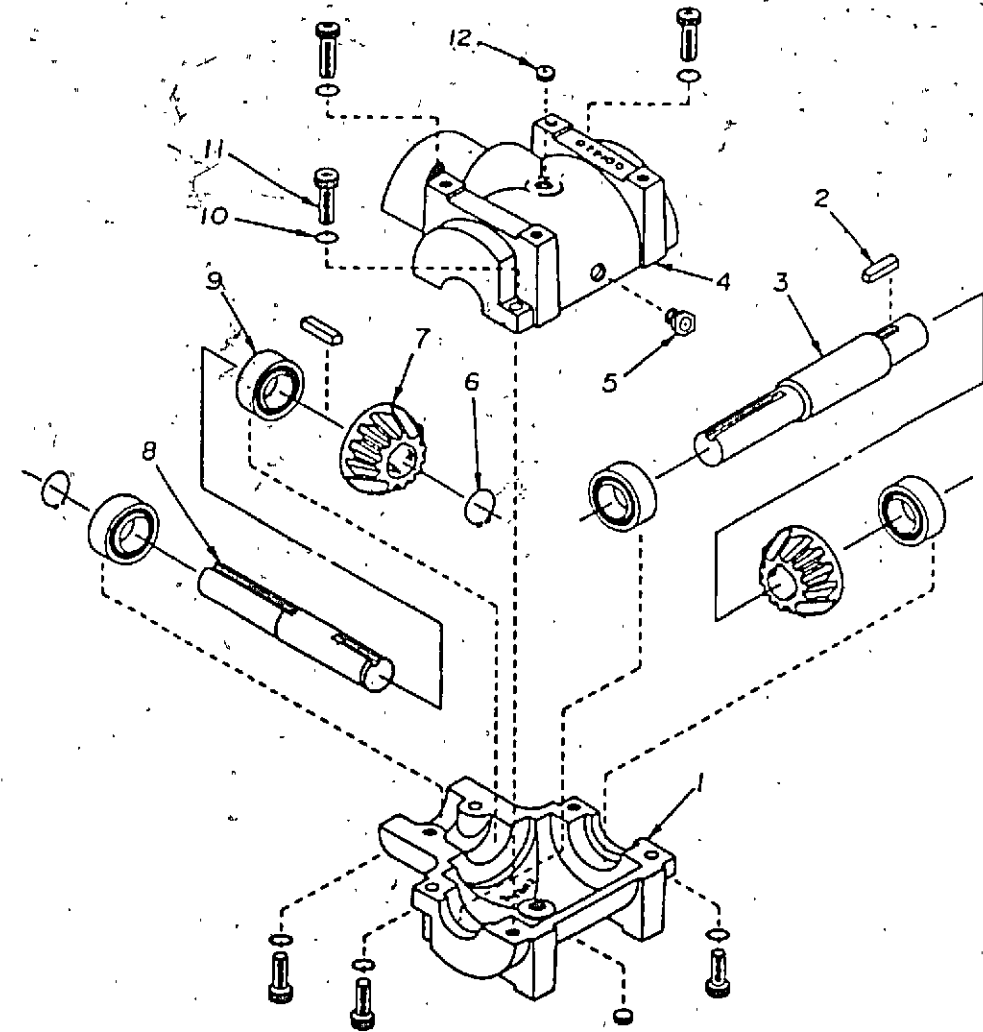
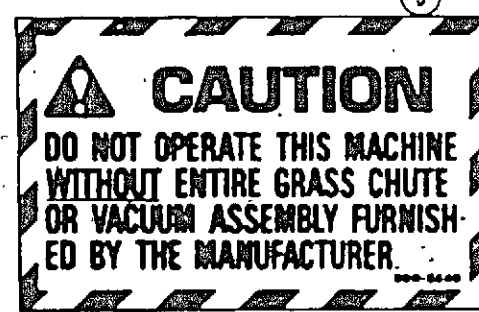
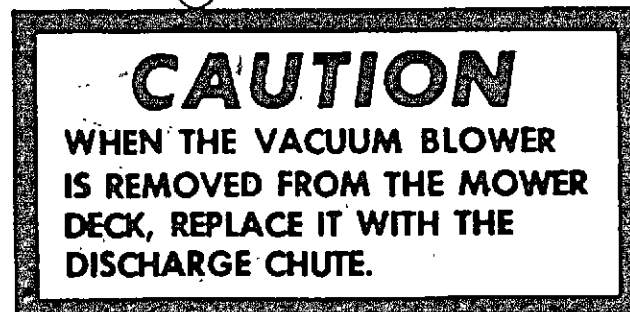

REF. NO.	PART NO.	DESCRIPTIONS
1.	900-7000	HOUSING HALF
2.	900-7001	KEY
3.	900-7002	SHAFT
4.	900-7003	HOUSING HALF
5.	900-7004	RELIEF VALVE
6.	900-7005	RETAINING RING
7.	900-7006	GEAR
8.	900-7007	SHAFT
9.	900-7008	BALL BEARING
10.	900-7009	LOCKWASHER
11.	900-7010	ALLEN HEAD BOLT
12.	900-7011	PIPE PLUG



GRAZER GROUND MOWERS

Models

**G1642, 0042-T, 0042T12, 0042TC12,
42A12, 42AC12, 42A, 42AC,
0042TCSS, 0042TCII
42" MOWER DECK
(as used on 12hp mowers and up)**

Parts List

TABLE OF CONTENTS

CHAIN DRIVE MOWERS

G1642 DECK (1982)	B4
G1642 DECK (1983)	B6
0042-T DECK (1984-1986)	B8
0042T12, 0042TC12, G42A12, G42AC12 DECK PARTS (1987-1991)	B9
0042T12, 0042TC12, G42A12, G42AC12 DECK DRIVE (1987-1991)	B10
42A, 42AC DECK PARTS (1992 AND AFTER)	B12
42A, 42AC DECK DRIVE (1992 AND AFTER)	B14

HYDRAULIC DRIVE MOWERS

0042TCSS, 0042TCII DECK PARTS (1988-1991)	C1
0042TCSS, 0042TCII DECK DRIVE (1988-1991)	C2
42TCSS, 42TCII DECK PARTS (1992 AND AFTER)	C4
42TCSS, 42TCII DECK DRIVE (1992 AND AFTER)	C6

MISC.

DECALS	C7
GEAR BOX (1982-1987)	C8
GEAR BOX (1988 AND AFTER)	C10

APPLICATION CHART

DECK MODEL	YEAR USED	MOWER MODEL
G1642	1982-1983	G1642
0042-T	1984-1986	1600, 1800
0042T12, 0042TC12	1987-1991	G1250 (BEFORE S/N 09-08-0945)
0042A12, 0042AC12	1987-1991	G1250 (S/N 09-08-0945 AND AFTER)
42A, 42AC	1992 AND AFTER	G1250, G1600, G1800CD
0042TCSS	1988-1991	G1800, G1890
0042TCII	1988-1991	G2000CII
42TCSS	1992 AND AFTER	G1890, G2090
42TCII	1992 AND AFTER	G2000CII



Grazer Division, Ingersoll Equipment Company
Winneconne, WI 54986

G1642 MOWER DECK ASSEMBLY

1982

G1642 MOWER DECK ASSEMBLY

REF. NO.	PART NO.	NO. REQD.	DESCRIPTIONS.
1.	310-0000	1	MOWER DECK
2.	300-0001	1	COVER (SMALL)
3.	310-0003	1	COVER (LARGE)
4.	300-0035	1	FOOT GUARD
5.	310-0001	1	GEAR BOX MOUNT
6.	900-3507	4	GAGE WHEEL BUSHING
7.	300-0036	1	BELT GUARD
8.	300-0007	2	GAGE WHEEL MOUNT
9.	900-5534	3	SPRING WASHER
10.	300-0009	2	BRACKET, GAGE WHEEL MOUNT
11.	300-0010	2	FORK, GAGE WHEEL
12.	300-0011	2	AXLE, GAGE WHEEL
13.		2	GAGE WHEEL BOLT
14.	300-0024	2	DECK LIFT ARM BACK ADJUSTABLE
15.	300-0013	2	BUSHING, DECK LIFT ARM
16.	300-0014	1	CROSSBAR
17.	300-0029	1	BELT TIGHTENER
18.	300-0016	1	SPACER, IDLER
19.	900-2514	1	PULLEY, GEAR BOX (IN-PUT)
20.	900-2515	1	PULLEY, GEAR BOX (OUT-PUT)
21.	900-2508	2	PULLEY, IDLER
22.	900-2507	2	PULLEY, SPINDLE
23.	300-0017	3	WASHER, SPINDLE
24.	900-3505	6	BEARING SPINDLE
25.	300-0027	3	SPACER SPINDLE
26.	300-0025	3	HOUSING SPINDLE
27.	300-0026	2	SHAFT SPINDLE
28.	900-5530	3	BLADE
29.	300-0021	4	KEY SPINDLE
30.	300-0030	1	BELT TIGHTENER
31.	900-3004	1	BELT, DRIVE
32.	900-5518	2	CABLE, DECK
33.	900-5519	2	PINS, DECK
34.	900-5520	6	HAIR PIN
35.	900-5521	4	PINS, GAGE WHEEL
36.	900-4007	2	GAGE WHEEL
37.	900-5535	1	GEAR BOX
38.	300-0022	1	CROSS BAR PIN
39.	300-0023 L.H.	1	DECK LIFT ARM FRONT ADJUSTABLE L.H.
40.	300-0023 R.H.	1	DECK LIFT ARM FRONT ADJUSTABLE R.H.
41.	900-2516	1	PULLEY, DOUBLE A
42.	900-2517	1	PULLEY, LEFT SIDE SPINDLE
43.	900-3006	1	BELT, DECK LONG
44.	900-3007	1	BELT, DECK SHORT
45.	310-0002	1	SMALL COVER
46.	310-0005	1	FOOT GUARD MOUNT
47.	310-0004	1	DECK MOUNT
48.	300-0033	1	SHAFT, SPINDLE LONG

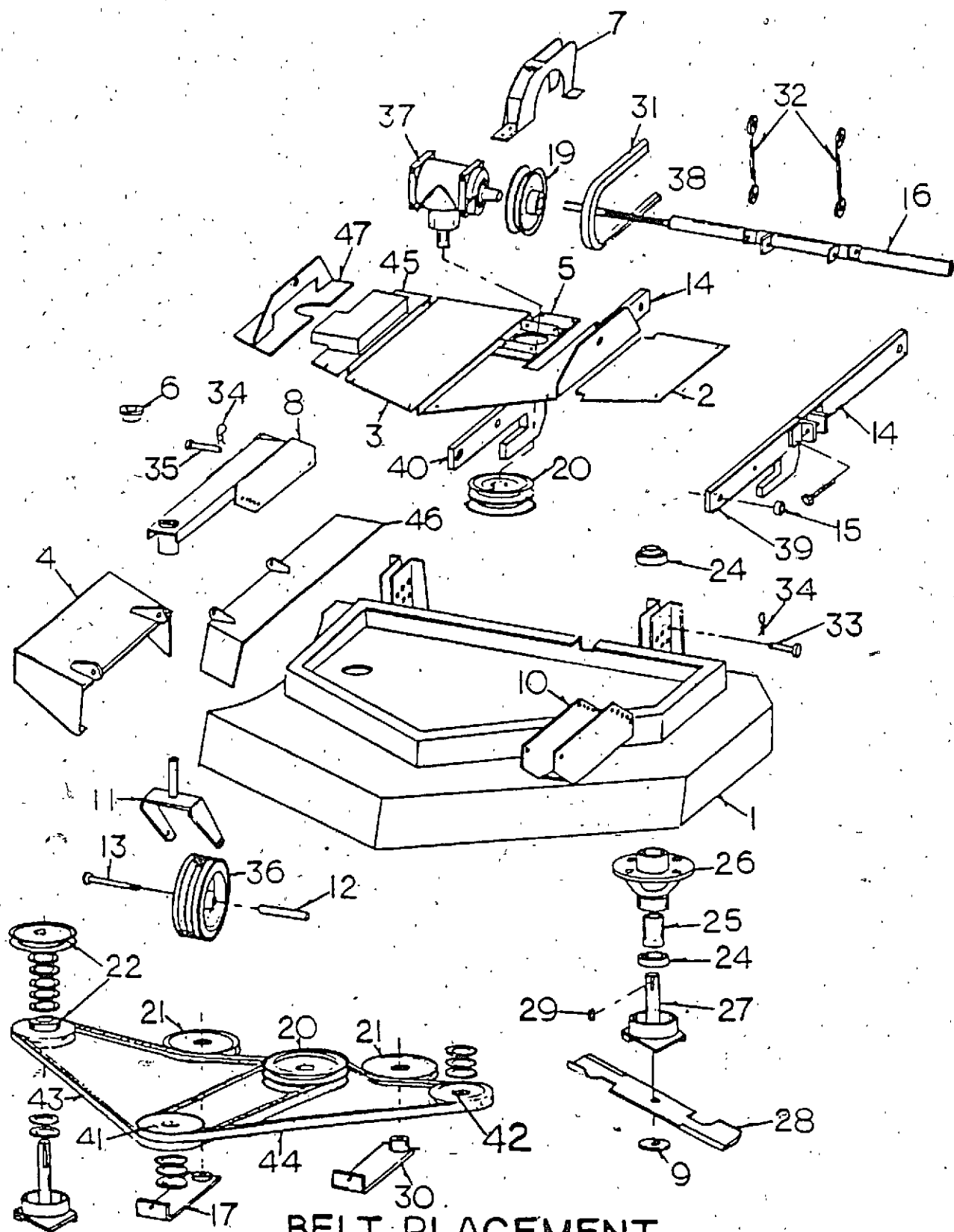

BELT PLACEMENT
DIAGRAM

G1642 MOWER DECK ASSEMBLY

1983

G1642 MOWER DECK ASSEMBLY

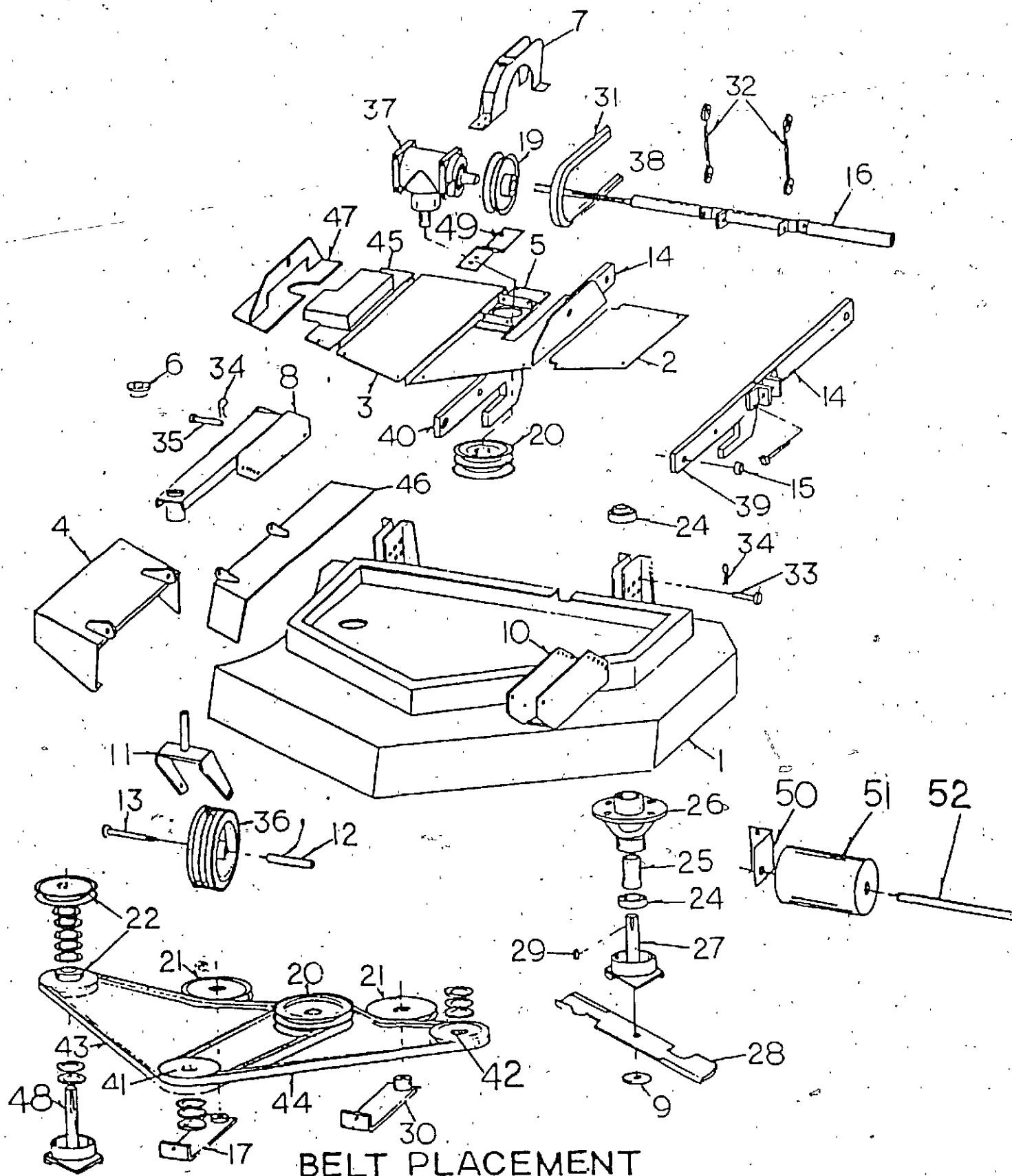

BELT PLACEMENT
DIAGRAM

REF. NO.	PART NO.	NO. REQED.	DESCRIPTIONS
1.	310-0000	1	MOWER DECK
2.	300-0001	1	COVER (SMALL)
3.	310-0003	1	COVER (LARGE)
4.	300-0035	1	FOOT GUARD
5.	310-0001	1	GEAR BOX MOUNT
6.	900-3507	4	GAGE WHEEL BUSHING
7.	300-0036	1	BELT GUARD
8.	300-0007	2	GAGE WHEEL MOUNT
9.	900-5534	3	SPRING WASHER
10.	300-0009	2	BRACKET, GAGE WHEEL MOUNT
11.	300-0010	2	FORK, GAGE WHEEL
12.	300-0011	2	AXLE, GAGE WHEEL
13.	-----	2	GAGE WHEEL BOLT
14.	300-0024	2	DECK LIFT ARM BACK ADJUSTABLE
15.	300-0013	2	BUSHING, DECK LIFT ARM
16.	300-0014	1	CROSSBAR
17.	300-0029	1	BELT TIGHTENER
18.	300-0016	1	SPACER, IDLER
19.	900-2514	1	PULLEY, GEAR BOX (IN-PUT)
20.	900-2515	1	PULLEY, GEAR BOX (OUT-PUT)
21.	900-2518	2	PULLEY, IDLER
22.	900-2507	2	PULLEY, SPINDLE
23.	300-0017	3	WASHER, SPINDLE
24.	900-3506	6	BEARING SPINDLE
25.	300-0027	3	SPACER SPINDLE
26.	300-0025	3	HOUSING SPINDLE
27.	300-0026	2	SHAFT SPINDLE
28.	900-5530	3	BLADE
29.	300-0021	4	KEY SPINDLE
30.	300-0030	1	BELT TIGHTENER
31.	900-3004	1	BELT, DRIVE
32.	900-5518	2	CABLE, DECK
33.	900-5519	2	PINS, DECK
34.	900-5520	6	HAIR PIN
35.	900-5521	4	PINS, GAGE WHEEL
36.	900-4007	2	GAGE WHEEL
37.	900-5535	1	GEAR BOX
38.	300-0022	1	CROSS BAR PIN
39.	300-0023 L.H.	1	DECK LIFT ARM FRONT ADJUSTABLE L.H.
40.	300-0023 R.H.	1	DECK LIFT ARM FRONT ADJUSTABLE R.H.
41.	900-2516	1	PULLEY, DOUBLE A
42.	900-2517	1	PULLEY, LEFT SIDE SPINDLE
43.	900-3006	1	BELT, DECK LONG
44.	900-3007	1	BELT, DECK SHORT
45.	310-0002	1	SMALL COVER
46.	310-0005	1	FOOT GUARD MOUNT
47.	310-0004	1	DECK MOUNT
48.	300-0033	1	SHAFT, SPINDLE LONG
49.	310-0006	1	BELT SUPPORT
50.	300-0037	1	ROLLER BRACKET
51.	900-5559	1	RUBBER ROLLER
52.	300-0038	1	ROLLER SHAFT

42" DECK
0042-T

0042-T
42 MOWER DECK ASSEMBLY

REF. NO.	PART NO.	NO. REQED.	DESCRIPTION
1.	310-0000	1	MOWER DECK
2.	300-0001	1	COVER (SMALL)
3.	310-0003	1	COVER (LARGE)
4.	320-0003	1	FOOT GUARD
5.	310-0001	1	GEAR BOX MOUNT
6.	900-3507	4	GAGE WHEEL BUSHING
7.	311-0002	1	BELT GUARD
8.	300-0007	2	GAGE WHEEL MOUNT
9.	900-5534	3	SPRING WASHER
10.	300-0009	2	BRACKET, GAGE WHEEL MOUNT
11.	300-0010	2	FORK, GAGE WHEEL
12.	300-0011	2	AXLE, GAGE WHEEL
13.	-----	2	GAGE WHEEL BOLT
14.	301-0024	1	DECK LIFT ARM BACK ADJUSTABLE
15.	300-0013	2	BUSHING, DECK LIFT ARM
16.	300-0014	1	CROSSBAR
17.	300-0029	1	BELT TIGHTENER
18.	300-0016	1	SPACER, IDLER
19.	900-2525	1	PULLEY, GEAR BOX (IN-PUT)
20.	900-2515	1	PULLEY, GEAR BOX (OUT-PUT)
21.	900-2518	2	PULLEY, IDLER
22.	900-2507	2	PULLEY, SPINDLE
23.	300-0017	3	WASHER SPINDLE
24.	900-3506	6	BEARING, SPINDLE
25.	300-0027	3	SPACER, SPINDLE
26.	300-0025	3	HOUSING, SPINDLE
27.	300-0026	2	SHAFT, SPINDLE
28.	900-5530	3	BLADE
29.	300-0021	4	KEY SPINDLE
30.	300-0030	1	BELT TIGHTENER
31.	900-3004	1	BELT, DRIVE
32.	900-5518	2	CABLE, DECK
33.	900-5519	2	PINS, DECK
34.	900-5520	6	HAIR PIN
35.	900-5521	4	PINS, GAGE WHEEL
36.	900-4007	2	GAGE WHEEL
37.	900-5535	1	GEAR BOX
38.	300-0022	1	CROSS BAR
39.	300-0023L.H.	1	DECK LIFT ARM FRONT ADJUSTABLE
40.	300-0023R.H.	1	DECK LIFT ARM FRONT ADJUSTABLE
41.	900-2516	1	PULLEY, DOUBLE A
42.	900-2517	1	PULLEY, LEFT SIDE SPINDLE
43.	900-3006	1	BELT, DECK LONG
44.	900-3007	1	BELT, DECK SHORT
45.	310-0002	1	SMALL COVER
46.	320-0010	1	FOOT GUARD MOUNT
47.	310-0004	1	DECK MOUNT
48.	300-0033	1	SHAFT, SPINDLE LONG
49.	300-0037	1	ROLLER BRACKET
50.	900-5559	1	RUBBER ROLLER
51.	300-0038	1	SHAFT, ROLLER
52.	300-0038	1	SHAFT, ROLLER
53.	301-0024L.H.	1	DECK LIFT ARM BACK ADJUSTABLE
54.	310-0006	1	GEAR BOX MOUNT ANGLE

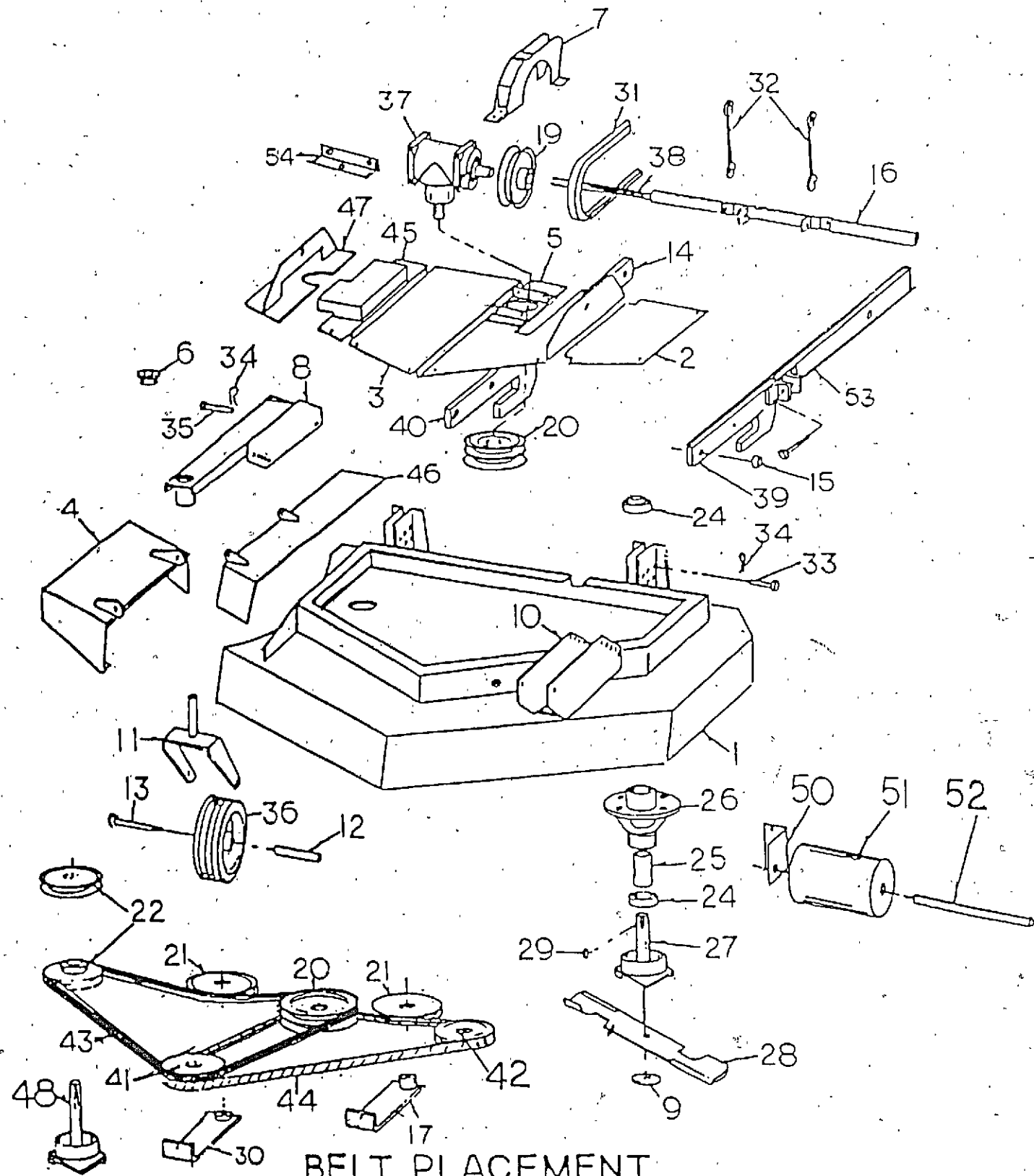

BELT PLACEMENT
DIAGRAM

0042T12 & 0042TC12

1989 - 1991

G42A12 & G42AC12

42" DECK PARTS

Item	Part No.	Description	Qty.	Item	Part No.	Description	Qty.
1	G3100000G	Deck	1		G9004006	Tire, 11 x 4.00-5	-
2	G3200015G	Foot Guard	1		G9004005	Rim, 5"	-
3	G3200016G	Foot Guard Mount	1		G9003505	Bearing, Wheel Assembly	-
4	G3100002G	Pulley Cover	1	15	310018H5C	Hex Bolt, 1/4-20 x 4 1/2", GR5 (0042T & G42A Deck)	2
5	G3100003G	Center Cover	1		314022C	Hex Bolt, 1/2-13 x 6 1/2", GR2 (0042TC & G42AC Deck)	-
6	G3000001G	Cover, LH	1	16	G9006096	Wing Bolt	4
7	G3100007	Shoe, LH	1	17	G9006092	Handle Nut	4
8	G9005559	Anti-scalp Roller	1	18	G9002044	10 Amp Circuit Breaker	1
9	G3000038	Shaft & Bracket	1	19	G9005510	Set Collar, 1"	2
10	G3000044	Gauge Wheel Mount Bracket	2	20	G9003501	Bearing, 1"	4
11	G3000043	Gauge Wheel Mount	2	21	G9005615	Fas-tatch Pin	1
12	G3200018	Fork (0042T & G42A Deck)	2	22	G9005519	Deck Pin	2
	G3300007	Fork (0042TC & G42AC Deck)	-	23	C9005520	Hair Pin Cotter	2
13	G3200008	Axle (0042T & G42A Deck)	2	24	G3100004	Deck Mount	1
	G2000017	Axle (0042TC & G42AC Deck)	-	25	G9005562	Spring	1
14	G9004007	Gauge Wheel Ass'y. (0042T & G42A Deck)	2	26	G9006043	Thumb Screw, 1/4-20 x 1/2"	4
	G9003510	Wheel Assembly Bearing	-				
	G9004004	Gauge Wheel Ass'y. (0042TC & G42AC Deck)	-				

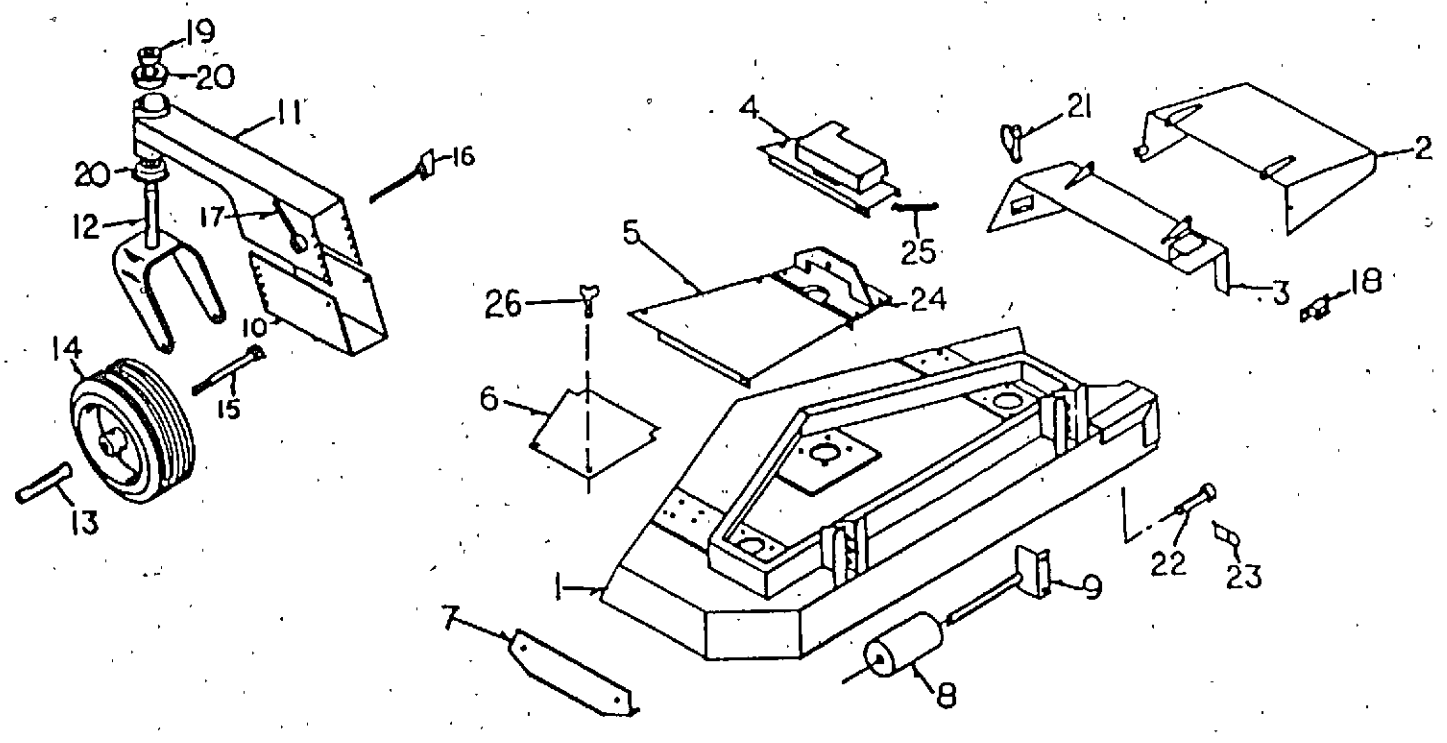

0042T12 & 0042TC12

1987 - 1991

G42A12 & G42AC12

42" DECK DRIVE

Item	Part No.	Description	Qty.	Item	Part No.	Description	Qty.
1	G3110001G	Gearbox Mount (Serial Numbers 09-08-0945 & Up)	1	16	G9002516	Spindle Pulley, Double A 4" - 1/4"	1
	G3100001G	Gearbox Mount (Serial Numbers Prior to 09-08-0945)	1	17	G9002515	Gearbox Pulley, Output Hub (Included w/G9002515)	1
2	G3110002	Belt Guard	1	18	G9002518	Idler Pulley	2
3	G3100006	Gearbox Mount Angle	1	20	G9002525	Gearbox Pulley, Input	1
4	G3000029	Belt Tightener	1	21	G9003004	Deck Drive Belt	1
5	G3000030	Belt Tightener	1	22	G9003006	Deck Belt	1
6	G3000025	Spindle Housing	3	23	G9003007	Deck Belt	1
7	G3000027	Spindle Spacer	3	24	G9005842	Gearbox	1
8	G9003506	Spindle Bearing, 7/8"	6	25	30103H5C	Hex Bolt, 5/16-24 x 3/4", GR5	3
9	G3000026	Spindle Shaft	2	26	G3000017	Washer, 5/16", 10 GA	3
10	G3000033	Spindle Shaft	1	27	40611	Key Stock, 3/16" x 1"	6
11	G9005531	Blade	3	28	300115C	Hex Tap Bolt, 1/4-20 x 4"	2
12	G9005534	Blade Washer	3	29	G9002528	Spindle Pulley	1
13	30206H5C	Hex Bolt, 3/8-24 x 1 1/4", GR5	3		G6000000	Spindle Housing Ass'y. (Includes Items 6, 7 & 8)	3
14	G9002507	Spindle Pulley	3		G6000022G	Gearbox Mount Ass'y. (Includes Items 1, 3, 17, 18 & 24)	1
15	G9006002	Spacer Washer	9				

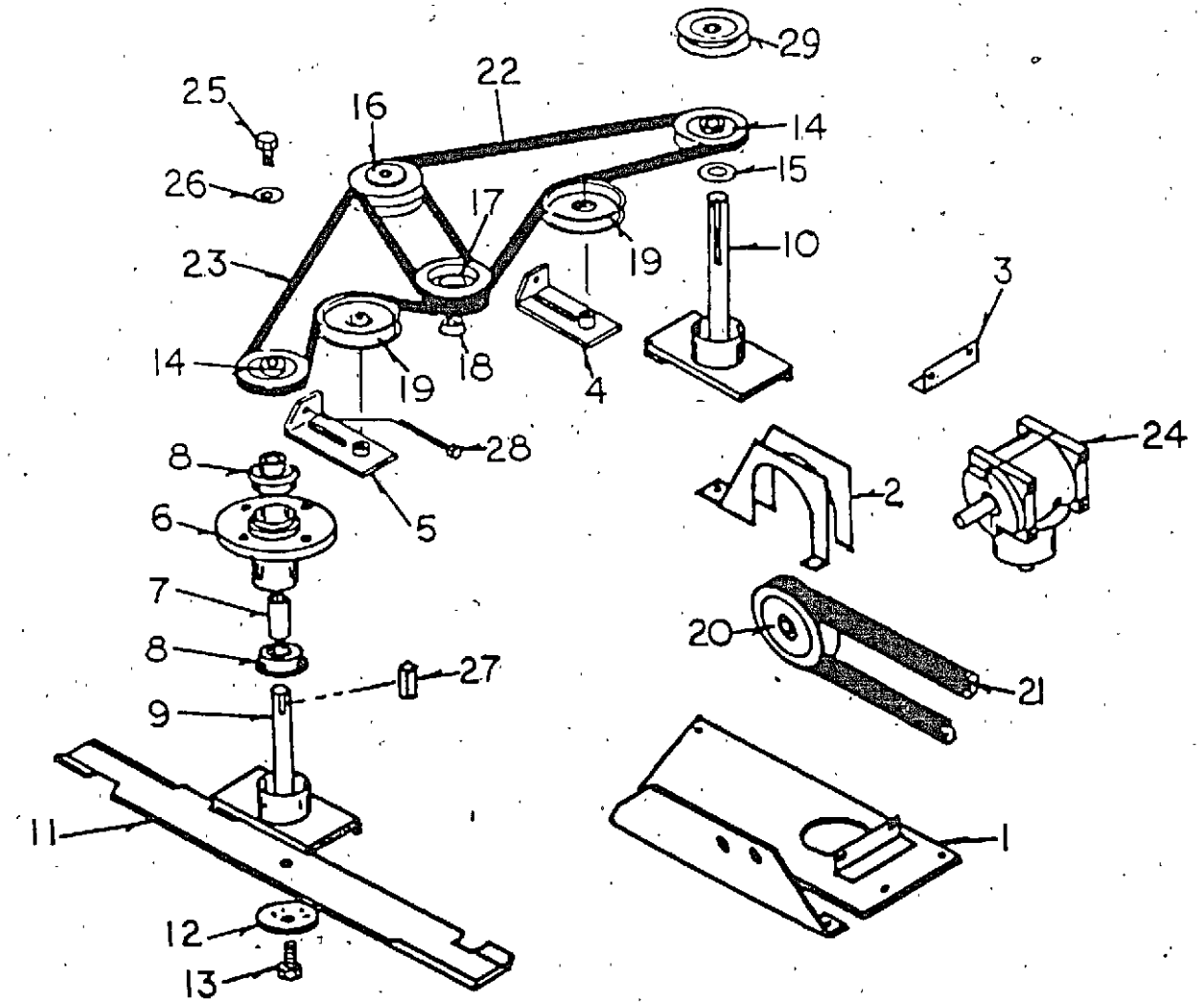

MOWER DECK AND ATTACHING PARTS (42")

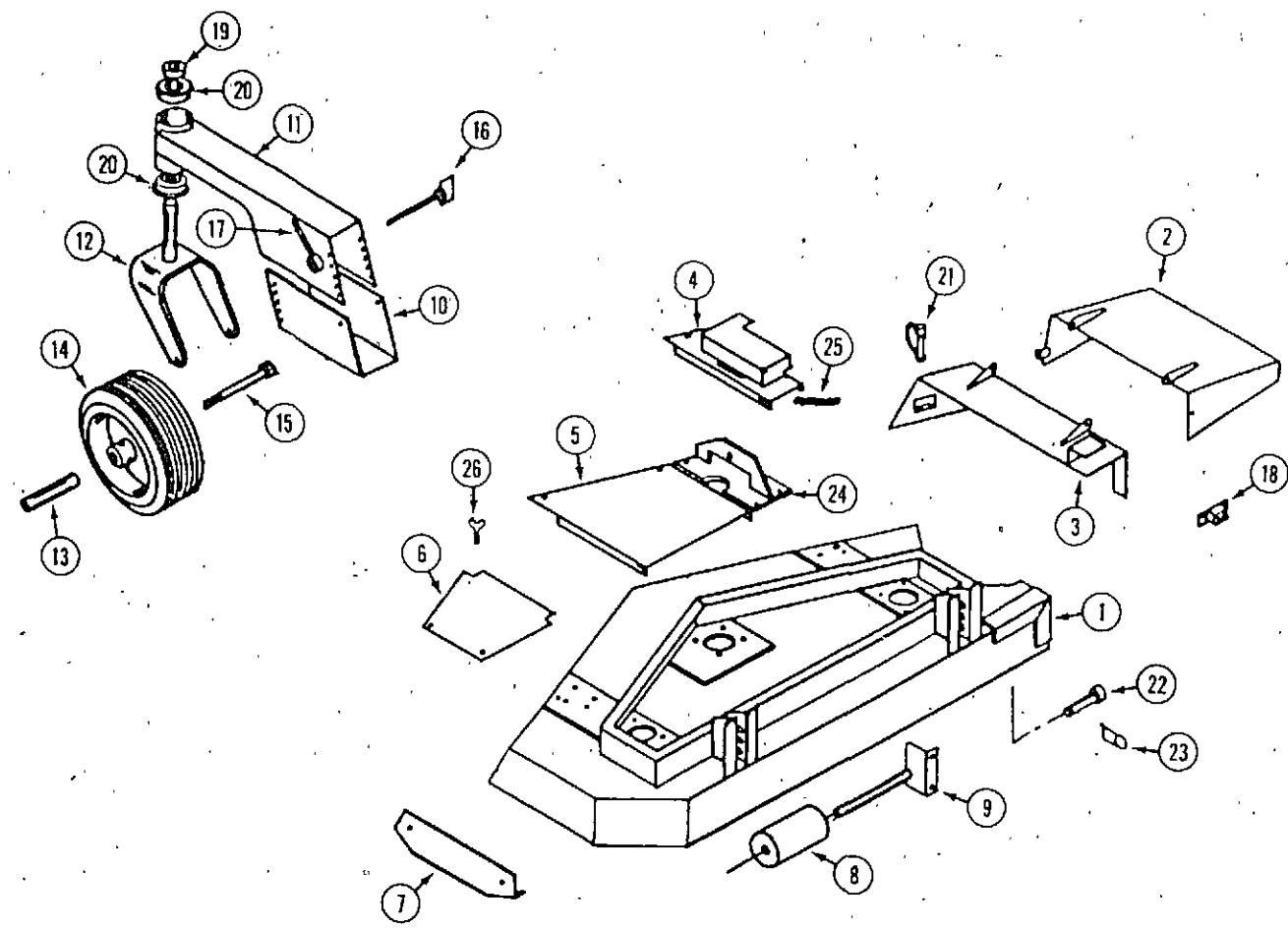

REF.	PART NO.	DESCRIPTION	REQ'D
1	C 41249	DECK - 42"	1
2	C 44612	CHUTE - foot guard	1
3	C 39209	MOUNT - foot guard	1
4	C 41255	COVER - pulley	1
5	C 41259	COVER - center	1
6	C 38107	COVER - L.H.	1
7	C 37909	SHOE - skid L.H.	1
8	C 37910	ROLLER - anti-scalp	1
9	C 37911	SHAFT - roller	1
10	C 37912	BRACKET - gauge wheel mount	2
11	C 37913	MOUNT - gauge wheel	2
12	C 37914	FORK - (42AC)	2
12	C 38030	FORK - (42A)	2
13	C 37915	AXLE - wheel (42AC)	2
13	C 38031	AXLE - wheel (42A)	2
14	C 37916	WHEEL - gauge (42AC)	2
14	C 38032	WHEEL - gauge (42A)	2
	C 37917	TIRE - 11 x 4.00 - 5	1
	C 37918	RIM - 5"	1
	C 44499	BEARING - wheel (42AC)	2
	C 38033	BEARING - wheel (42A)	2
15	113- 54	BOLT - 1/4" - 20 x 4-1/2" (42A)	2
15	113- 2419	BOLT - 1/2" - 13 x 6-1/2" (42AC)	2
16	C 37920	BOLT - wing	4
17	C 37921	NUT - gauge wheel handle	4
18	C 37505	BREAKER - circuit 10 amp	1
19	C 37860	COLLAR - set 1"	2
20	C 37824	BEARING - 1"	4
21	C 37922	PIN - "fas-tatch"	1
22	141- 56	PIN - deck	2
23	C 38096	PIN - cotter, hair	2
24	C 37925	MOUNT - deck	1
25	C 37926	SPRING -	1
26	NSS	SCREW - thumb 1/4" - 20 x 1/2" (use 113-3 and 192-19)	4

MOWER DRIVE (42")

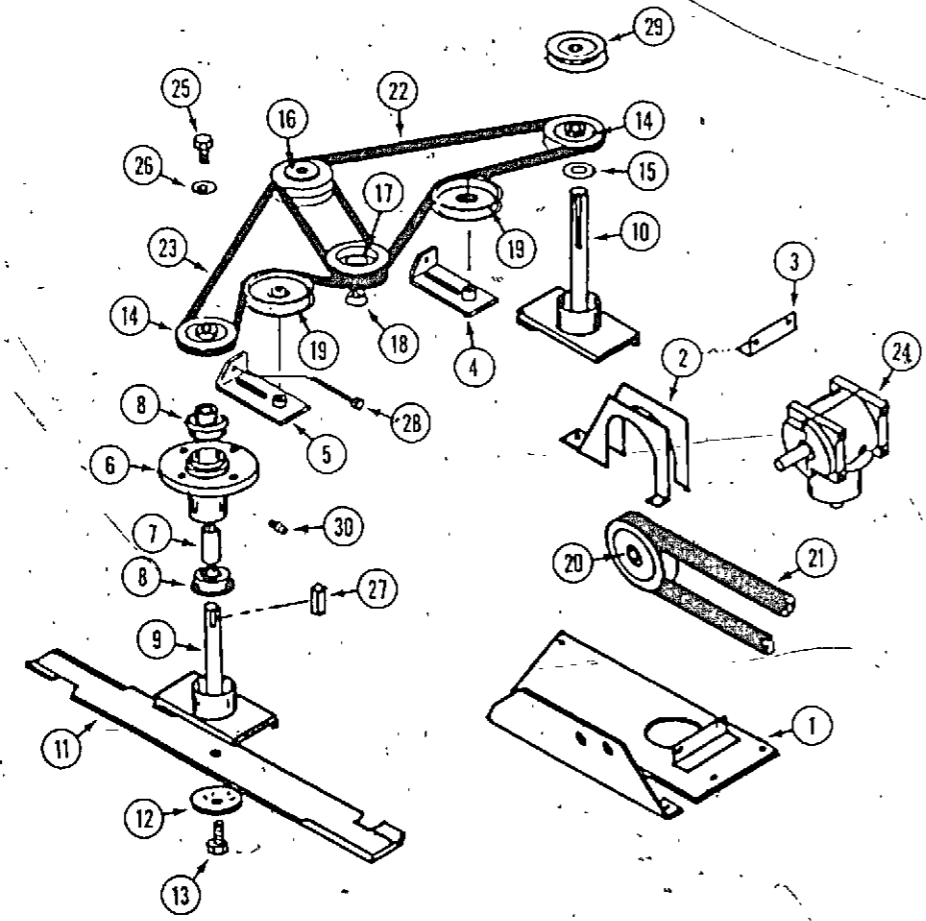

REF.	PART NO.	DESCRIPTION	REQ'D
1	C 38063	MOUNT - gear box (use before S/N 09-08-0945)	1
1	C 41269	MOUNT - gear box (use S/N 09-08-0945 and after)	1
2	C 37875	GUARD - belt (early production)	1
3	C 37877	ANGLE - gear box mount	1
4	C 37878	TIGHTENER - belt	1
5	C 37879	TIGHTENER - belt	1
6	C 37902	HOUSING ASSEMBLY - spindle (includes ref. 7, 8, 30)	3
6	C 37880	HOUSING - spindle	3
7	C 37881	SPACER - spindle	3
8	C 42786	BEARING - spindle	6
9	C 37883	SHAFT - spindle	2
10	C 37884	SHAFT - spindle	1
11	C 38036	BLADE	3
12	C 37886	WASHER - blade	3
13	1-14- 201	BOLT - 3/8" - 24 x 1-1/4"	3
14	C 37887	PULLEY - spindle	2
15	C 37888	WASHER - spacer	9
16	C 37889	PULLEY - spindle, double	1
17	C 37890	PULLEY - gear box output	1
18	C 41658	HUB - pulley	1
19	C 37891	PULLEY - idler	2
20	C 37892	PULLEY - gear box input	1
21	C 37894	BELT - drive	1
22	C 37896	BELT - deck	1
23	C 37897	BELT - deck	1
24	C 44917	GEAR BOX - see page 53 for repairs	1
25	114- 102	BOLT - 5/16" - 24 x 3/4"	3
26	C 37900	WASHER - 5/16", 10 ga.	3
27	C 29581	KEY - 3/16" x 3/16" x 1"	6
28	C 37901	BOLT - 1/4" - 20 x 4"	2
29	C 38037	PULLEY - spindle	1
30	219- 20	FITTING - grease 1/4" - 28	3

42" DECK PARTS

Item	Part No.	Description	Qty.	Item	Part No.	Description	Qty.
1	G310000G	Deck	1		G9004005	Rim, 5"	-
2	G3200015G	Foot Guard	1		G9003505	Bearing, Wheel Assembly	-
3	G3200016G	Foot Guard Mount	1	15	314022C	Hex Bolt, 1/2-13 x 6 1/2", GR2	2
4	G3100002G	Pulley Cover	1	16	G9006096	Wing Bolt	4
5	G3100003G	Center Cover	1	17	G9006092	Handle Nut	4
6	G3000001G	Cover, LH	1	18	G9002044	10 Amp Circuit Breaker	1
7	G3100007	Shoe, LH	1	19	G9005510	Set Collar, 1"	2
8	G9005559	Anti-scalp Roller	1	20	G9003501	Bearing, 1"	4
9	G3000038	Shaft & Bracket	1	21	G9005615	Fas-tatch Pin	1
10	G3000044	Gauge Wheel Mount Bracket	2	22	G9005519	Deck Pin	2
11	G3000043	Gauge Wheel Mount	2	23	G9005520	Hair Pin Cotter	2
12	G3300007	Fork	2	24	G3100004	Deck Mount	1
13	G2000017	Axle	2	25	G9005562	Spring	1
14	G9004004	Gauge Wheel Assembly	2	26	G9006043	Thumb Screw, 1/4-20 x 1/2"	4
	G9004006	Tire, 11 x 4.00-5	-				

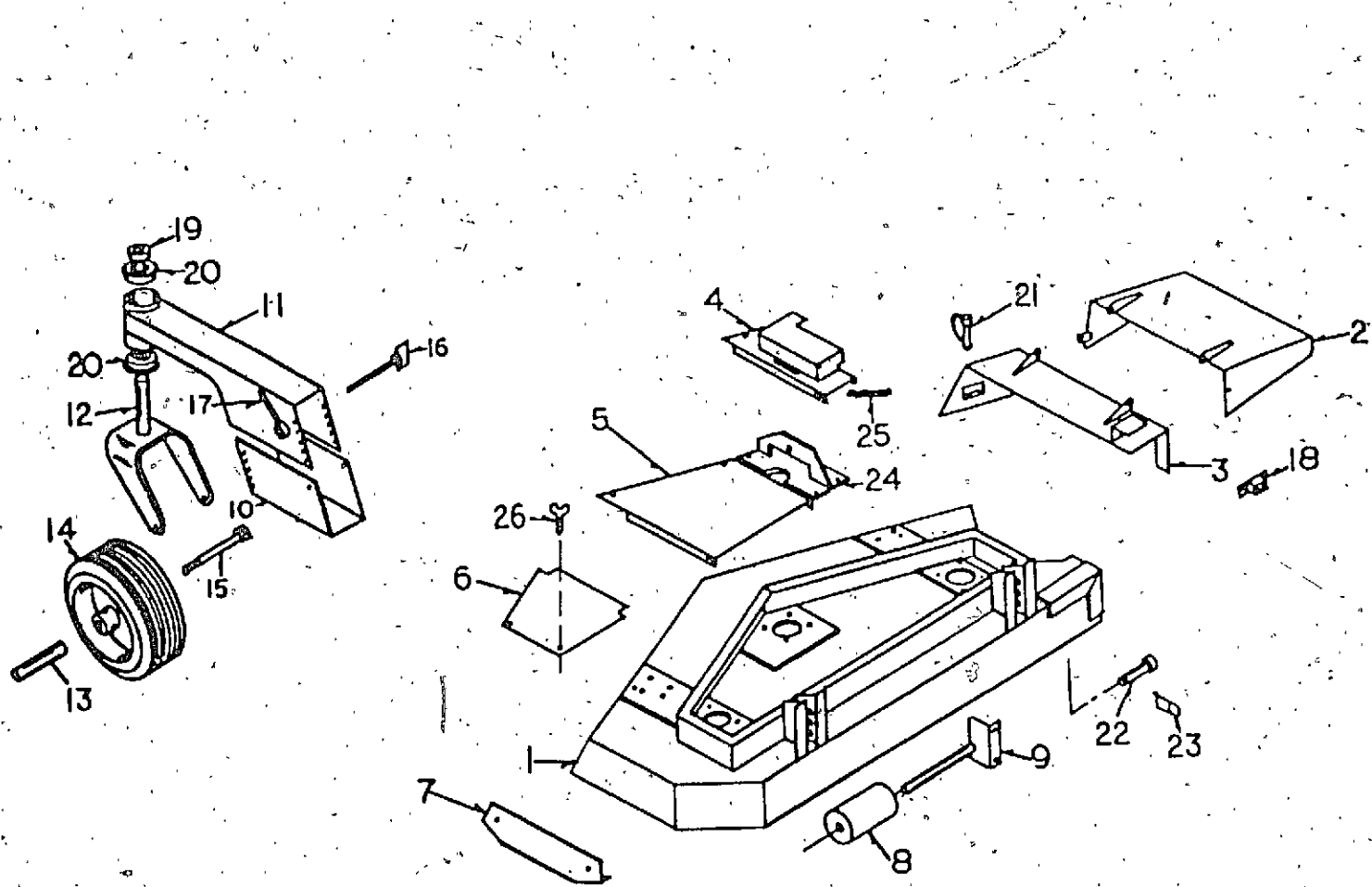

Item	Part No.	Description	Qty.	Item	Part No.	Description	Qty.
1	G3110001G	Gearbox Mount	1	17	G9002515	Gearbox Pulley, Output	1
2	G3110002	Belt Guard (1800)	1	18		Hub (Included w/G9002515)	1
	G3300030	Belt Guard (2000)	1	19	G9002518	Idler Pulley	2
3	G3100006	Gearbox Mount Angle	1	20	G9002525	Gearbox Pulley, Input (1800 & 1890)	1
4	G3000029	Belt Tightener	1		G9002543	Gearbox Pulley, Input (2000)	1
5	G3000030	Belt Tightener	1	21	G9003004	Deck Drive Belt (1800 & 1890)	1
6	G3000025	Spindle Housing	3		G9003009	Deck Drive Belt (2000)	2
7	G3000027	Spindle Spacer	3	22	G9003006	Deck Belt	1
8	G9003506	Spindle Bearing	6	23	G9003007	Deck Belt	1
9	G3000026	Spindle Shaft	2	24	G9005535	Gearbox	1
10	G3000033	Spindle Shaft	1	25	30103H5C	Hex Bolt, 5/16-24 x 3/4", GR5	3
11	G9005530	Blade	3	26	G3000017	Washer, 5/16", 10 GA	3
12	G9005534	Blade Washer	3	27	40611	Key Stock, 3/16" x 1"	6
13	30206H5C	Hex Bolt, 3/8-24 x 1 1/4", GR5	3	28	300115C	Hex Tap Bolt, 1/4-20 x 4"	2
14	G9002507	Spindle Pulley	3		G6000000	Spindle Housing Assembly (Includes Items 6, 7 & 8)	3
15	G9006002	Spacer Washer	9				
16	G9002516	Spindle Pulley, Double A	1				

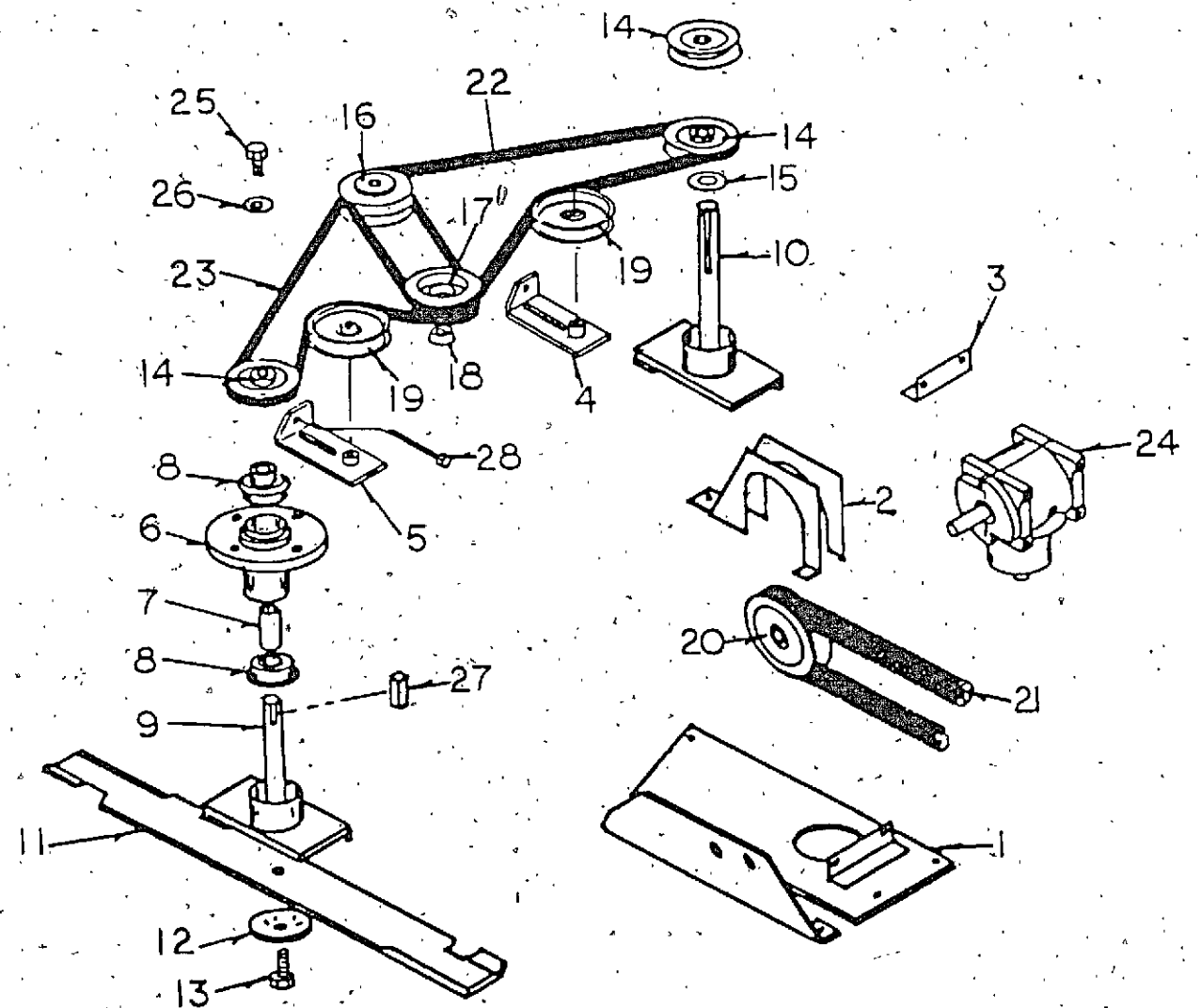

42" MOWER DECK AND ATTACHING PARTS

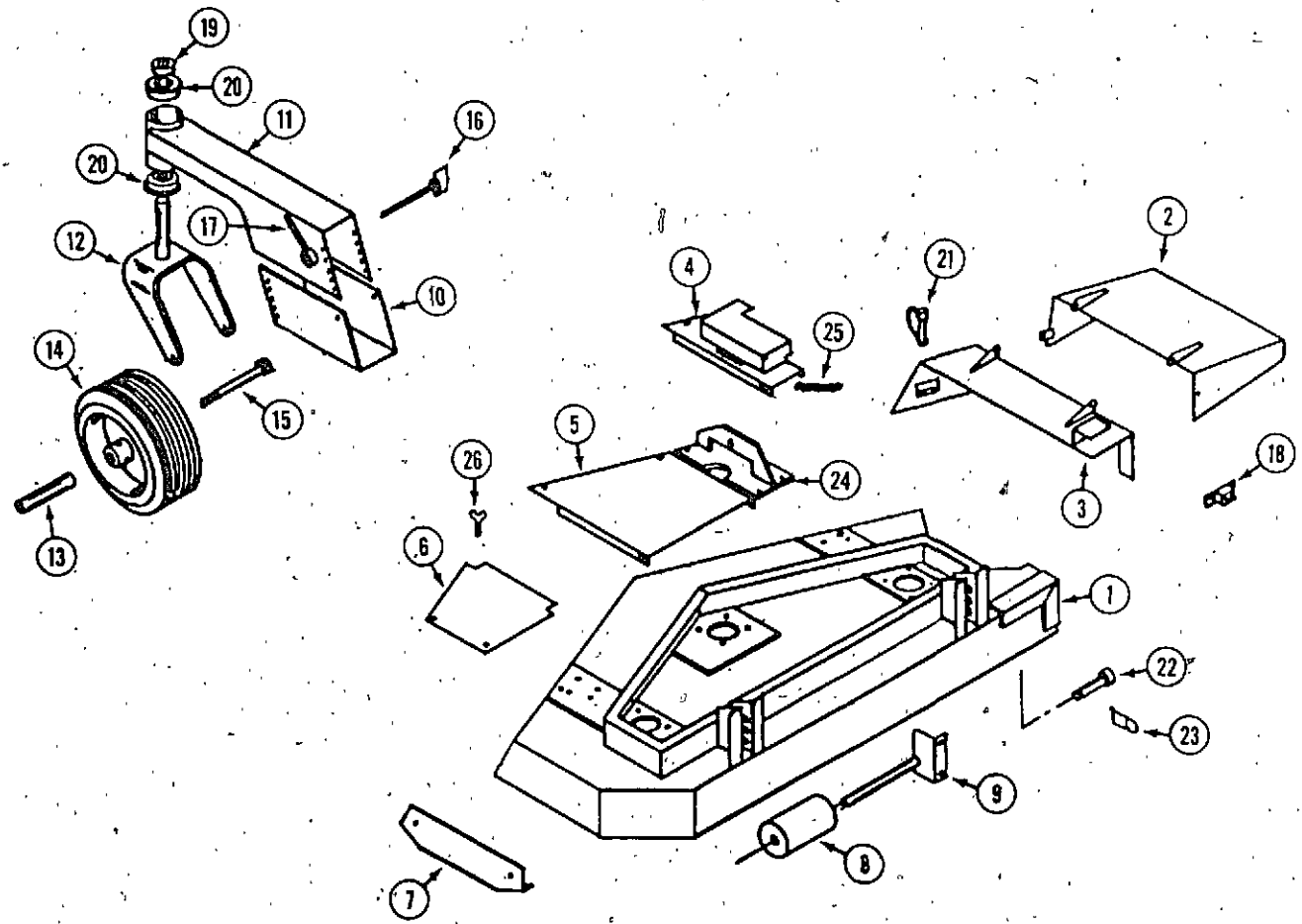

REF.	PART NO.	DESCRIPTION	REQ'D
1	C 41249	DECK - 42"	1
2	C 39208	CHUTE - foot guard	1
3	C 39209	MOUNT - foot guard	1
4	C 41255	COVER - pulley	1
5	C 41259	COVER - center	1
6	C 41237	COVER - L.H.	1
7	C 37909	SHOE - skid L.H.	1
8	C 37910	ROLLER - anti-scalp	1
9	C 37911	SHAFT - roller	1
10	C 37912	BRACKET - gauge wheel mount	2
11	C 37913	MOUNT - gauge wheel	2
12	C 37914	FORK - (2000)	2
12	C 38030	FORK - (1800SS, 1800KSS, 1890, 1890K, 1890V)	2
13	C 37915	AXLE - wheel (2000)	2
13	C 38031	AXLE - wheel (1800SS, 1800KSS, 1890, 1890K, 1890V)	2
14	C 37916	WHEEL - gauge (2000)	2
14	C 38039	WHEEL - gauge (1800SS, 1800KSS, 1890, 1890K, 1890V)	2
	C 38033	BEARING - wheel (1800SS, 1800KSS, 1890, 1890K, 1890V)	2
	C 37917	TIRE - 11 x 4.00 - 5 (2000)	1
	C 37918	RIM - 5" (2000)	1
	C 44499	BEARING - wheel (2000)	2
15	113-2419	BOLT - 1/2" - 13 x 6-1/2" (2000)	2
15	C 38034	BOLT - axle (1800SS, 1800KSS, 1890, 1890K, 1890V)	2
16	C 37920	BOLT - wing	4
17	G 37921	NUT - gauge wheel handle	4
18	C 37505	BREAKER - circuit 10 amp	1
19	C 37860	COLLAR - set 1"	2
20	C 37824	BEARING - 1"	4
21	C 37922	PIN - "fas-tatch"	1
22	E-10821	PIN - deck	2
23	C 38096	PIN - cotter, hair	2
24	C 37925	MOUNT - deck	1
25	C 37926	SPRING	1
26	NSS	SCREW - thumb 1/4" - 20 x 1/2" (use 113-3 and 192-19)	4

42TCSS & 42TCII 1992 AND AFTER

42" MOWER DRIVE

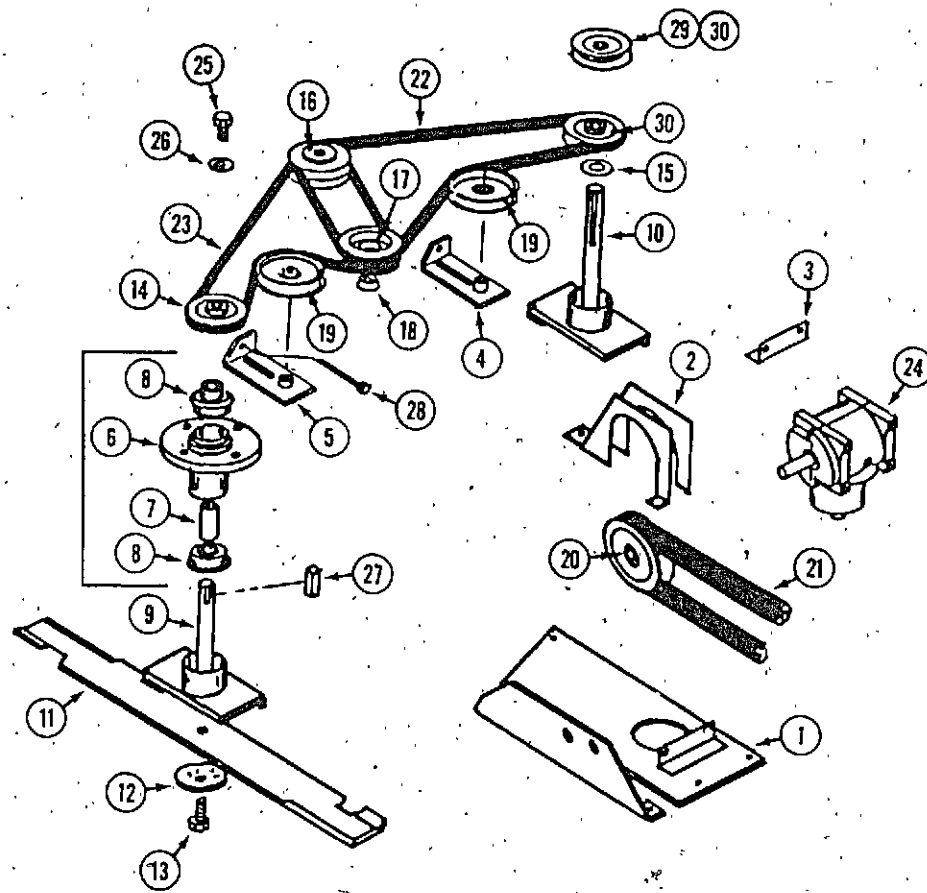

REF.	PART NO.	DESCRIPTION	REQ'D
1	C 41269	MOUNT - gear box	1
2	C 37875	GUARD - belt (1800SS, 1800KSS, 1890, 1890K)	1
2	C 37876	GUARD - belt (2000)	1
3	C 37877	ANGLE - gear box mount	1
4	C 37878	TIGHTENER - belt	1
5	C 37879	TIGHTENER - belt	1
6	C 37880	HOUSING - spindle	1
7	C 37881	SPACER - spindle	3
8	C 42786	BEARING - spindle	3
9	C 37883	SHAFT - spindle	6
10	C 37884	SHAFT - spindle	2
11	C 37885	BLADE - (2000)	1
11	C 38036	BLADE - (1800SS, 1800KSS, 1890, 1890K, 1890V)	3
12	C 37886	WASHER - blade	3
13	C 37557	BOLT - 3/8" - 24 x 1-1/4"	3
14	C 37887	PULLEY - spindle	2
15	C 37888	WASHER - spacer	9
16	C 37889	PULLEY - spindle, double	1
17	C 37890	PULLEY - gear box output	1
18	C 41658	HUB - pulley	1
19	C 37891	PULLEY - idler	2
20	C 37892	PULLEY - gear box input (1800SS, 1800KSS, 1890, 1890K, 1890V)	1
20	C 37893	PULLEY - gearbox input (2000)	1
21	C 37894	BELT - drive (1800SS, 1800KSS, 1890, 1890K)	1
21	C 37895	BELT - drive (2000)	1
21	C 44241	BELT - drive (1890V)	1
22	C 37896	BELT - deck	1
23	C 37897	BELT - deck	1
24	C 37898	GEAR BOX - see page 83 for repairs (Curtis model)	1
25	C 39386	BOLT - 5/16" - 24 x 3/4"	3
26	C 37900	WASHER - 5/16", 10 ga.	3
27	C 29581	KEY - 3/16" x 3/16" x 1"	6
28	C 37901	BOLT - 1/4" - 20 x 4"	2
29	C 38037	PULLEY - spindle (1800SS, 1800KSS, 1890, 1890K, 1890V)	1
30	C 37887	PULLEY - spindle (2000)	1
31	C 37902	HOUSING ASSEMBLY - spindle (includes ref. 6, 7, 8)	1

DECALS (Deck)

REF.	PART NO.	DESCRIPTION	REQ'D
1	C 37491	DECAL - "Whirling Blades"	1
2	C 37492	DECAL - "Caution" discharge chute	1
3	C 37493	DECAL - "Caution" grass chute	1
4	C 37494	DECAL - "Danger"	1

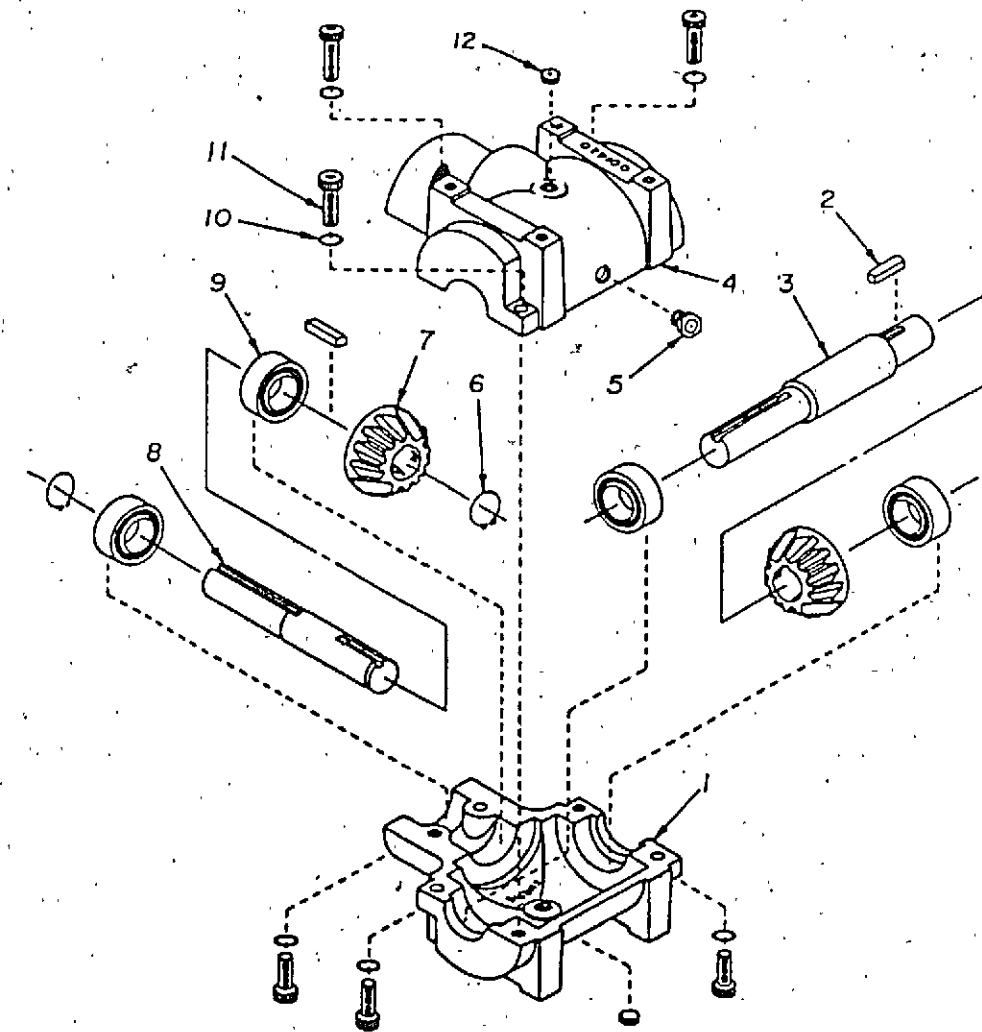
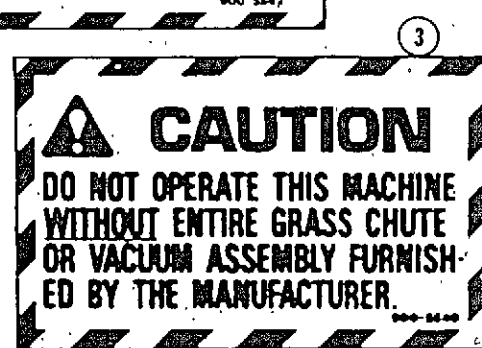
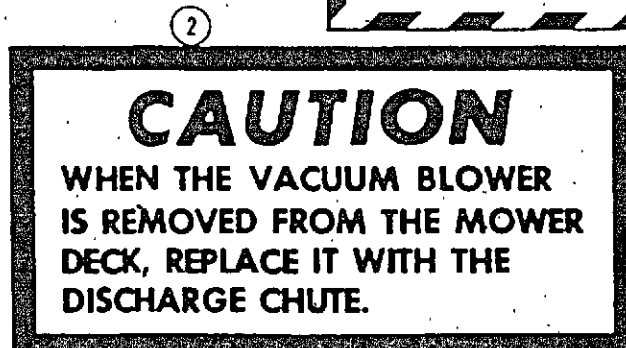

REF. NO.	PART NO.	DESCRIPTIONS
1.	900-7000	HOUSING HALF
2.	900-7001	KEY
3.	900-7002	SHAFT
4.	900-7003	HOUSING HALF
5.	900-7004	RELIEF VALVE
6.	900-7005	RETAINING RING
7.	900-7006	GEAR
8.	900-7007	SHAFT
9.	900-7008	BALL BEARING
10.	900-7009	LOCKWASHER
11.	900-7010	ALLEN HEAD BOLT
12.	900-7011	PIPE PLUG

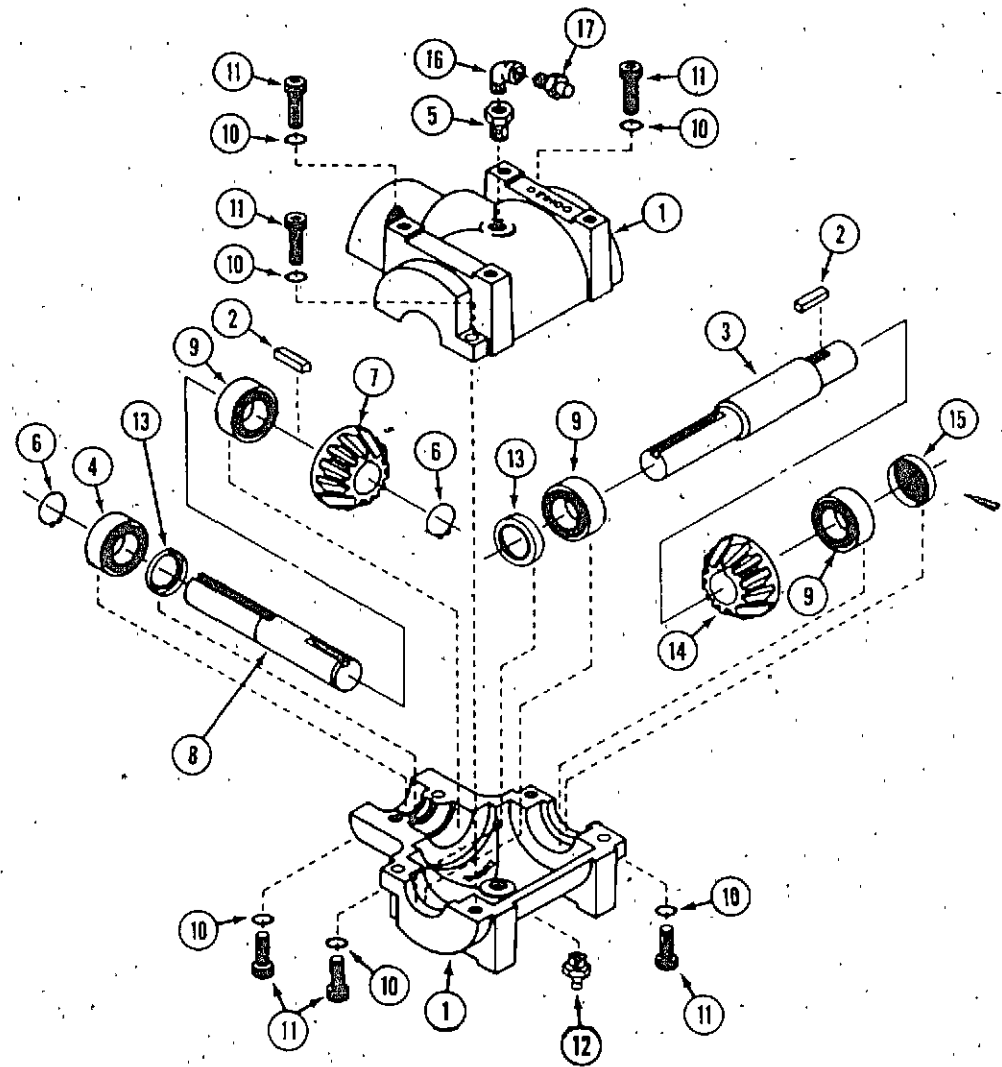

**GEAR BOX
(Curtis)**

1988 AND AFTER

REF.	PART NO.	DESCRIPTION	REQ'D
	C 37898	GEAR BOX	1
1	C 37959	HOUSING - half	2
2	C 29581	KEY - 3/16" x 3/16" x 1"	2
3	C 37960	SHAFT - input	1
4	C 37961	BEARING - ball	1
5	C 37962	BUSHING - pipe 1/4" x 1/8"	1
6	C 37963	RING - retaining	2
7	C 37964	GEAR - output shaft	1
8	C 37965	SHAFT - output	1
9	C 37966	BEARING - ball	3
10	C 37967	LOCKWASHER	6
11	C 37968	CAP SCREW - allen head	6
12	C 37974	FITTING - grease 1/4" NPT	1
13	C 37969	SEAL - shaft	2
14	C 37970	GEAR - input shaft	1
15	C 37971	PLUG - expansion	1
16	C 37541	ELBOW - street 1/8" x 90°	1
17	C 37973	VALVE - relief	1
	C 37975	GREASE - synthetic, cartridge	1

**GEAR BOX
(Superior)**

1	C 42924	SHAFT - pinion, with gear	1
2	C 42923	SHAFT - cross, with gear	1
3	C 42917	HOUSING - with tapped holes	1
4	C 42927	HOUSING - with thru holes (not shown)	1
5	C 42918	CUP - bearing	4
6	C 42921	CONE - bearing	4
7	C 42919	RING - retaining	1
8	C 42920	PLUG - pipe 1/4"	3
9	C 42922	SEAL - shaft	2
10	C 29581	KEY - 3/16" x 1" input shaft	1
11	C 42928	PIPE - vent	1
12	C 42926	BOLT - 5/16" x 1" socket head (not shown)	8
13	C 42925	CAP - end	1
14	C 28215	KEY - 3/16" x 5/8" output shaft	1

