

MOWER

ROTARY MOWER
 J41, K41, L41, M41, N41, P41
 SNOWCASTER
 J81, K81, L81, M81, N81, P81, R81
 UTILITY BLADE
 G51, H51, J51
 BAGGER
 B96

Parts Catalog No. D1232

5-85-RP-1000-139

NOTE: This Parts Catalog replaces the previous issue C1232 which is obsolete and should be discarded.

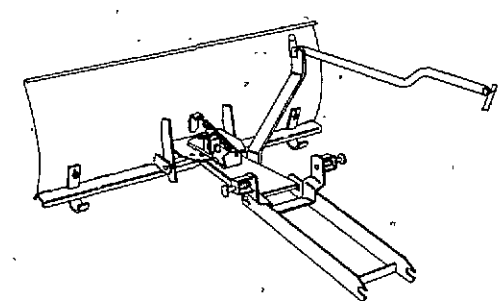

BLADE

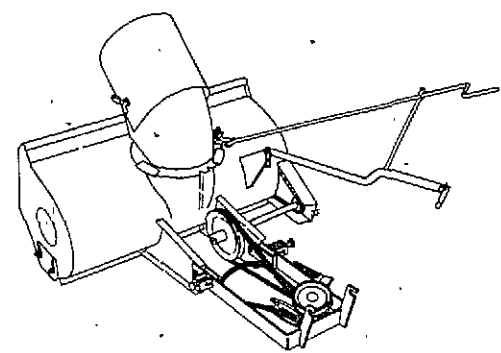

SNOWCASTER

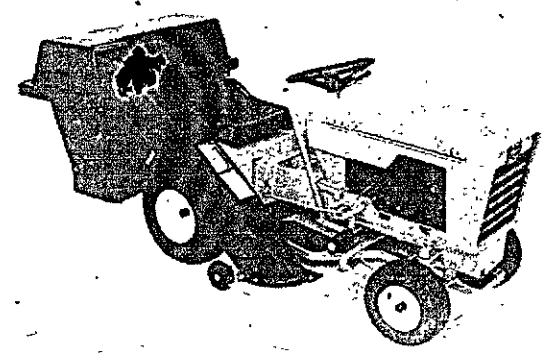

BAGGER

MODEL DESIGNATION

TRACTOR APPLICATION

MODEL DESIGNATION	107	117	108	118	110	116
J41, K41, L41, M41, N41, P41	X	X	X	X	X	X
J81, K81, L81, M81, N81, P81, R81	X	X	X	X	X	X
G51, H51, J51	X	X	X	X	X	X
B96*			X		X	X

* Requires Model P41 or later mower

ALPHABETICAL INDEX

BAGGER SECTION

	PAGE	GRID
Decals	39	E10
Entire Parts List	37	E8

MOWER SECTION

	PAGE	GRID
Decals	39	E10
J41	5-9	C4-C8
K41	11-15	C10-C14
L41, M41, N41	17-21	D2-D6
P41	23-27	D8-D12

SNOWCASTER SECTION

	PAGE	GRID
Decals	39	E10
Entire Parts List	29-33	D14-E4

UTILITY BLADE SECTION

	PAGE	GRID
Decals	39	E10
Entire Parts List	35	E6

NOTE: See grid A2 for -
 G41, H41 Rotary Mowers,
 G51 Snow Blade,
 G81 Snow Caster

NOTE: See grid F2 for -
 L47 Rear Discharge Rotary Mowers

DECK, BELT AND SPINDLE ASSEMBLY

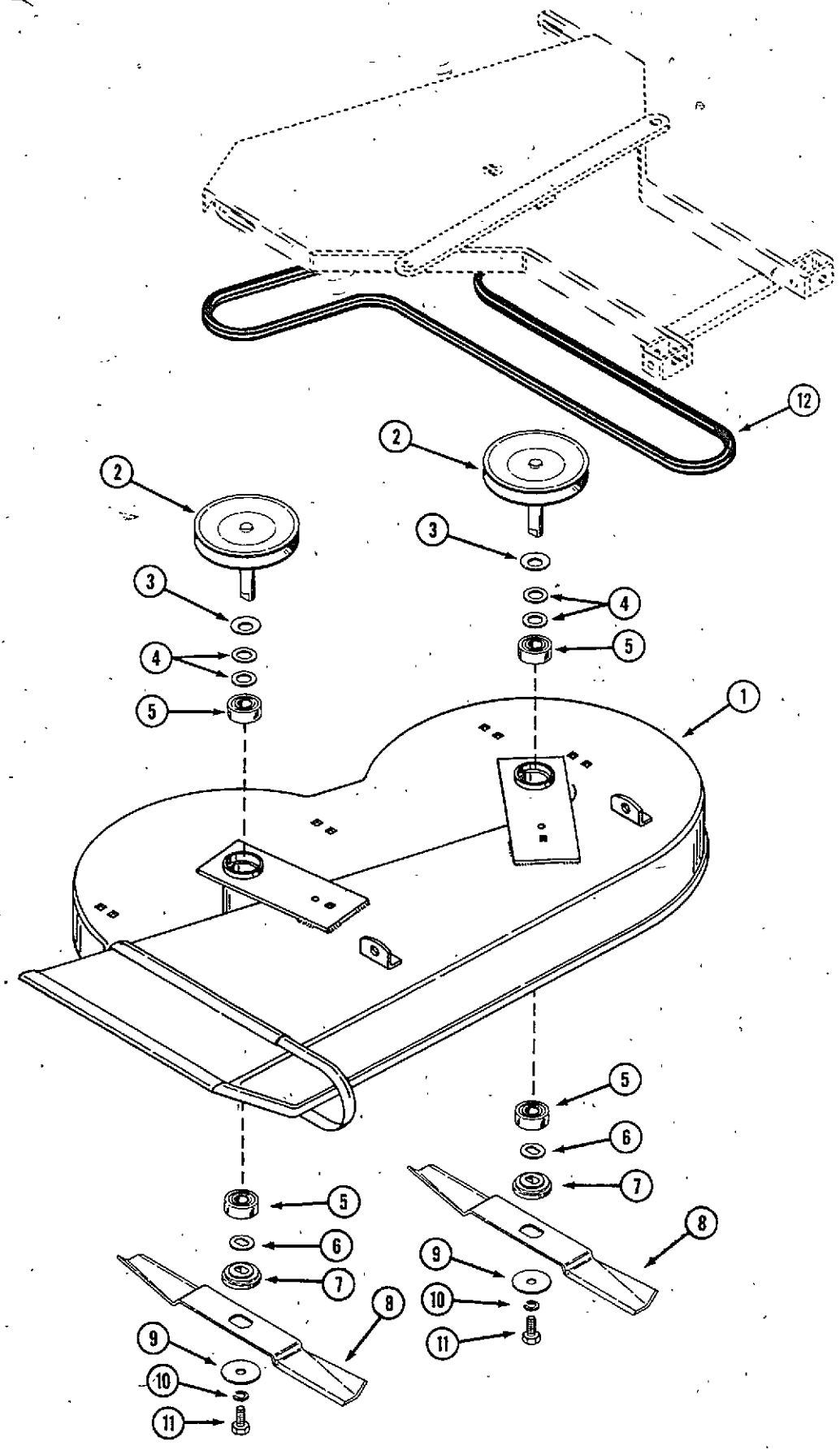

REF.	PART NO.	DESCRIPTION	REQ'D.
1	C 18905	DECK - mower 34"	1
2	C 17155	SPINDLE ASSEMBLY	2
3	C 15272	WASHER - spring	2
4	C 28972	WASHER - spindle	4
5	C 28971	BEARING - spindle	4
6	C 16719	WASHER - special, spindle	2
7	NSS	ADAPTER - spindle (use C25542 and C25544)	2
8	C 24797	BLADE - 17-1/4"	2
9	195- 2037	WASHER - 7/16" x 2" OD	2
10	192- 6	LOCKWASHER - 3/8"	2
11	113- 207	BOLT - 3/8 x 1" NC hex	2
12	C 17083	BELT - mower drive	1

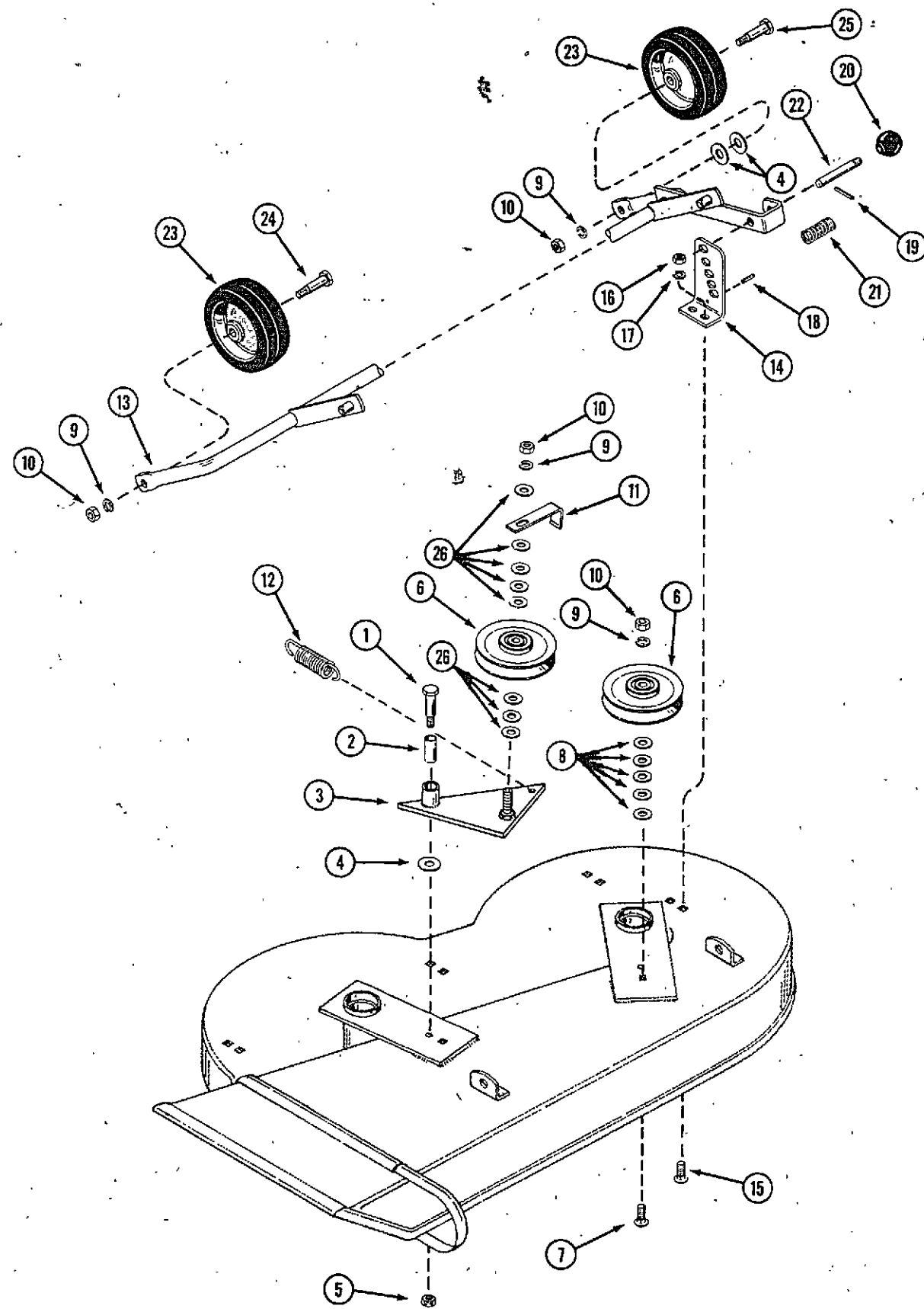

WHEELS, AXLE AND IDLERS

REF.	PART NO.	DESCRIPTION	REQ'D.
1	C 16745	BOLT - shoulder 3/8"	1
2	C 16714	BUSHING - idler arm	1
3	C 19084	ARM - idler	1
4	195- 533	WASHER - 1/2"	1
5	131- 178	NUT - lock 3/8" NC hex	3
6	C 17274	PULLEY - idler	1
7	111- 330	BOLT - 3/8" x 1-3/4" rd. hd. square neck	2
8	195- 103	WASHER - 3/8"	1
9	192- 21	LOCKWASHER - 3/8"	5
10	129- 103	NUT - 3/8" NC hex	4
11	C 17761	KEEPER - belt	4
12	C 15677	SPRING - idler arm	1
13	C 18899	AXLE - mower	1
14	C 16077	BRACKET - height adjust	1
15	111- 203	BOLT - 5/16" x 1" rd. hd. square neck	1
16	129- 102	NUT - 5/16" NC hex	2
17	192- 20	LOCKWASHER - 5/16"	2
18	138- 92	PIN - roll 3/16" x 3/4"	2
19	138- 77	PIN - roll	1
20	C 15618	KNOB - height adjust	1
21	C 10482	SPRING	1
22	C 15942	PIN - locking	1
23	C 26736	WHEEL - mower	1
24	C 16745	BOLT - shoulder, R.H.	2
25	C 14966	BOLT - shoulder, L.H.	1
26	195- 525	WASHER - 13/32"	8

AXLE MOUNTING AND LIFT ASSEMBLY

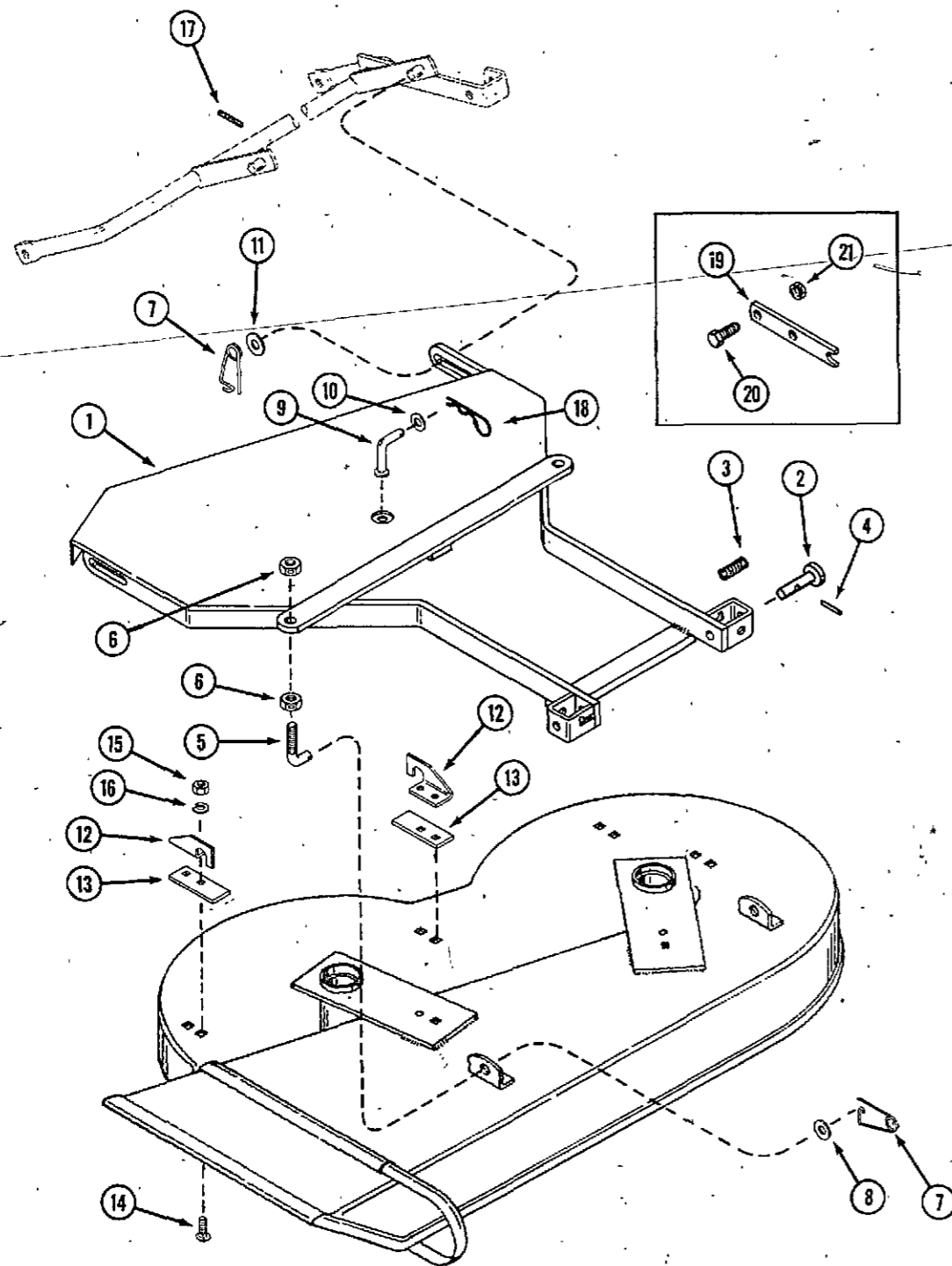

REF.	PART NO.	DESCRIPTION	REQ'D.
1	C 19456	BRACKET - lift assembly	1
2	C 15278	PIN - latch	2
3	C 10482	SPRING - latch	2
4	138- 2073	PIN - roll 3/16" x 1-1/4"	2
5	C 19088	"J" BOLT - adjusting	2
6	131- 1100	NUT - lock 1/2" NC hex	4
7	C 10898	PIN - safety	4
8	195- 529	WASHER - 7/16"	2
9	C 20006	PIN - lift	1
10	195- 525	WASHER - 3/8"	1
11	195- 106	WASHER - 1/2"	2
12	C 15351	BRACKET - axle mounting	3
13	C 15352	SPACER - axle	3
14	111- 203	BOLT - 5/16" x 1" rd. hd. square neck	6
15	129- 102	NUT - 5/16" NC hex	6
16	192- 20	LOCKWASHER - 5/16"	6
17	138- 96	PIN - roll 3/16" x 1"	1
18	C 16450	PIN - hair	1
19	C 27231*	BRACKET - lift adaptor	1
20	113- 207*	BOLT - 3/8" - 16 x 1" grade 5	1
21	131- 1181*	NUT - 3/8" - 16 lock	1

* Required to mount J41 mower on tractors S/N and after:
 108 - 14031940
 110 - 14032840
 116 - all

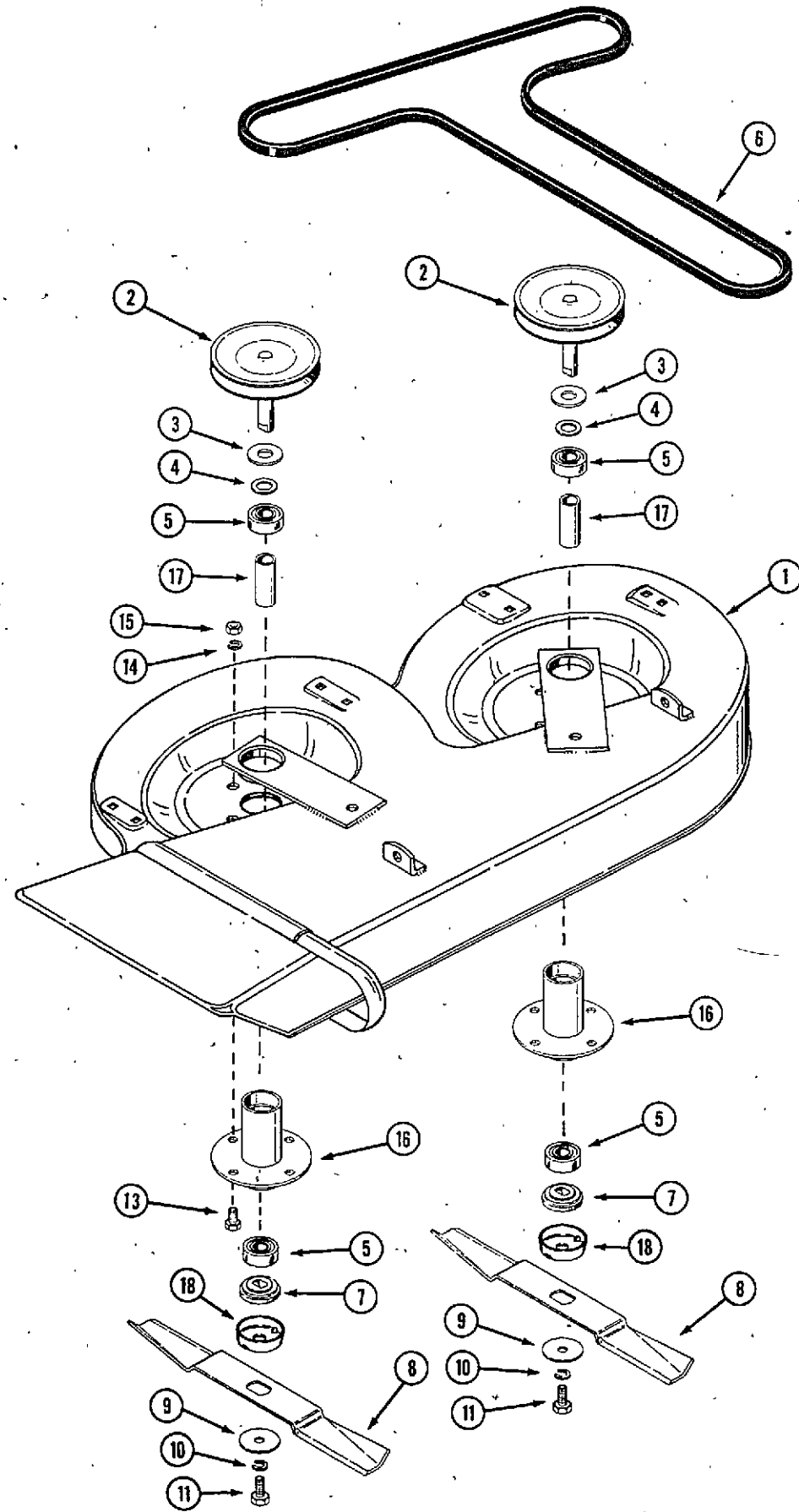

DECK, BELT AND SPINDLE ASSEMBLY

REF.	PART NO.	DESCRIPTION	REQ'D.
1	C 19457	DECK - mower 34"	1
2	C 17155	SPINDLE ASSEMBLY	2
3	C 10942	WASHER - spacer	2
4	C 28972	WASHER - spindle	4
5	C 28971	BEARING - spindle	4
6	C 17083	BELT - drive	1
7	C 25542	ADAPTER - spindle (also requires item 18 if not installed)	2
8	C 24797	BLADE - 17-1/4"	2
9	195- 2037	WASHER - 7/16" x 2" OD	2
10	192- 21	LOCKWASHER - 3/8"	2
11	113- 207	BOLT - 3/8 x 1" NC hex	2
12	C 17083	BELT - mower drive	1
13	113- 206	BOLT - 3/8 x 3/4" NC hex	8
14	192- 21	LOCKWASHER - 3/8"	8
15	129- 103	NUT - 3/8" NC hex	8
16	C 20009	HOUSING - spindle	2
17	C 21519	SPACER - spindle	2
18	C 25544	SHIELD - bearing	2

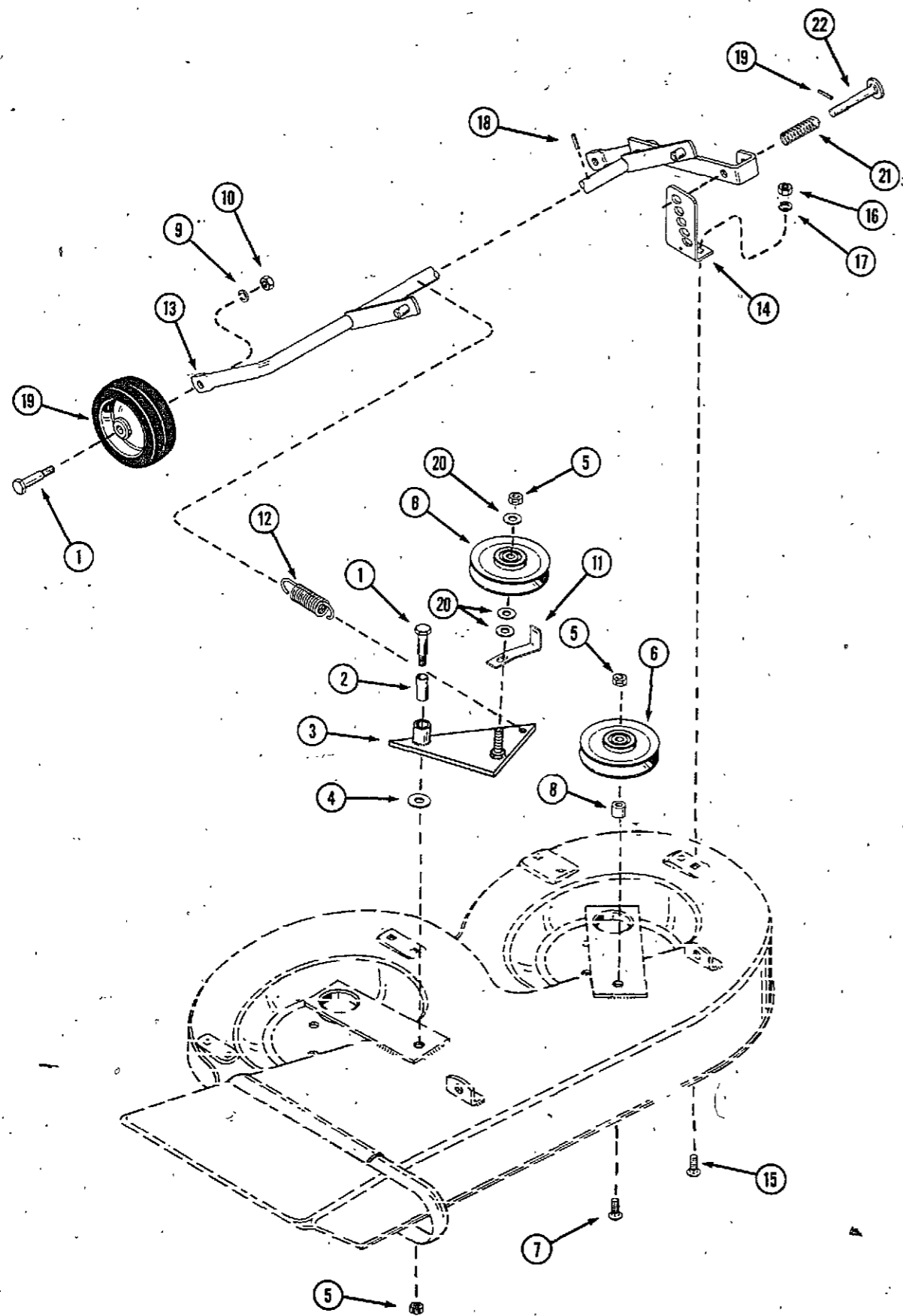

MODEL K41 ROTARY MOWER

WHEELS, AXLE AND IDLERS

REF.	PART NO.	DESCRIPTION	REQ'D.
1	C 16745	BOLT - shoulder 3/8"	3
2	C 16714	BUSHING - idler arm	1
3	C 20016	ARM - idler	1
4	195- 533	WASHER - 1/2"	3
5	131- 1181	NUT - lock 3/8" NC hex	3
6	C 17274	PULLEY - idler	2
7	12- 632	BOLT - 3/8" x 2" rd. hd. square neck	1
8	C 20017	SPACER - idler pulley	1
9	192- 21	LOCKWASHER - 3/8"	2
10	129- 103	NUT - 3/8" NC hex	2
11	C 20013	KEEPER - belt	1
12	C 15677	SPRING - idler	1
13	C 19273	AXLE - mower	1
14	C 19259	BRACKET - height adjust	1
15	111- 203	BOLT - 5/16" x 1" rd. hd. square neck	2
16	129- 102	NUT - 5/16" NC hex	2
17	192- 20	LOCKWASHER	2
18	138- 96	PIN - roll 3/16" x 1"	2
19	C 26736	WHEEL - mower	2
20	195- 525	WASHER - 13/32 x 13/16" O.D.	3
21	C 10482	SPRING - locking pin	1
22	C 20005	PIN - locking	1

AXLE MOUNTING AND LIFT ASSEMBLY

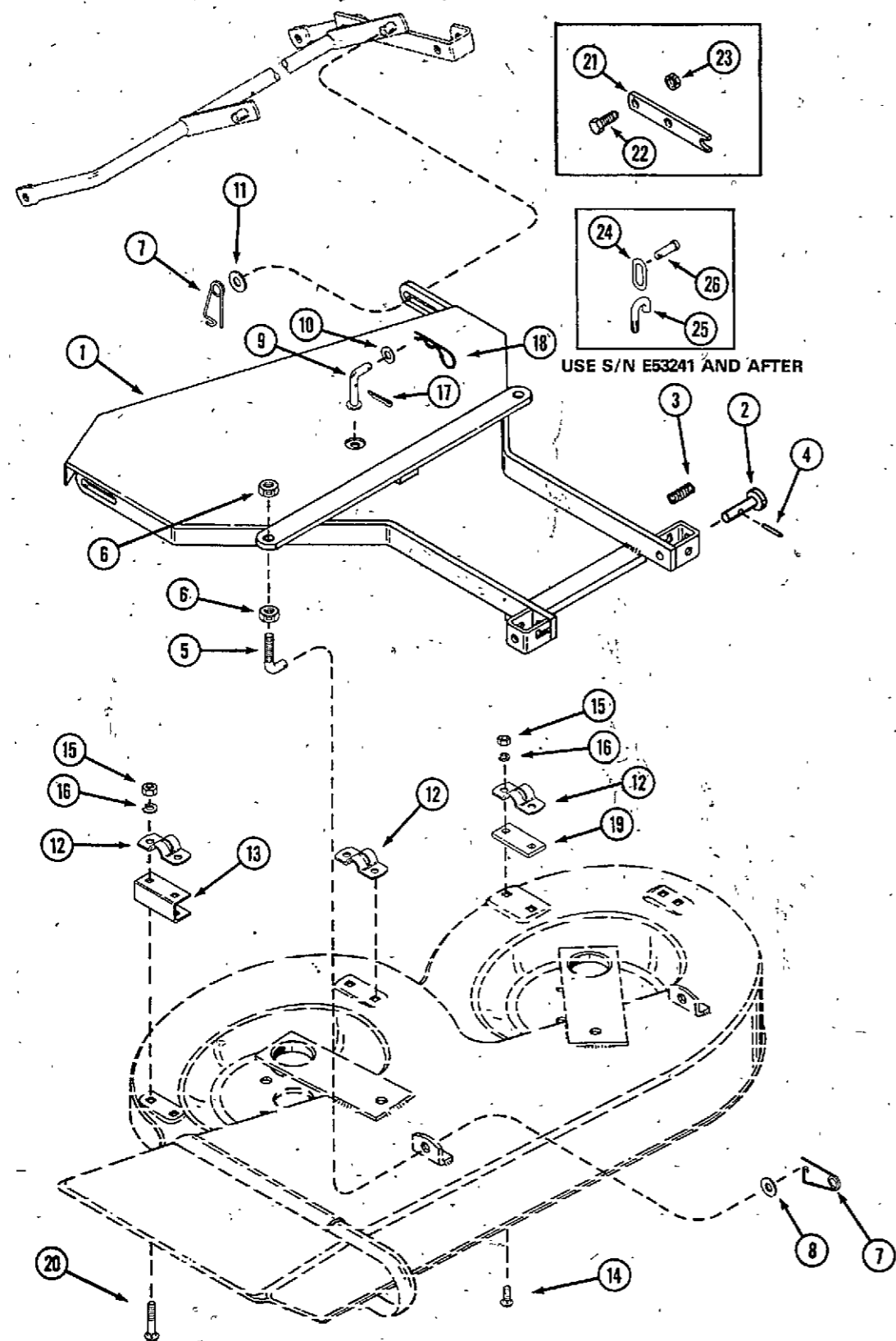

REF.	PART NO.	DESCRIPTION	REQ'D.
1	C 19456	BRACKET - lift assembly	1
2	C 15278	PIN - latch	2
3	C 10482	SPRING - latch	2
4	138- 2073	PIN - roll 3/16" x 1-1/4"	2
5	C 19088	"J" BOLT - adjusting	2
6	131- 1181	NUT - lock 1/2" NC hex	4
7	C 10898	PIN - safety	4
8	195- 529	WASHER - 7/16"	2
9	C 20006	PIN - lift	1
10	195- 525	WASHER - 3/8"	1
11	195- 106	WASHER - 1/2"	2
12	C 18029	BRACKET - saddle	3
13	C 20007	SPACER - axle 1-1/4"	3
14	111- 202	BOLT - 5/16" x 3/4" rd. hd. square neck	4
15	129- 102	NUT - 5/16" NC hex	8
16	192- 20	LOCKWASHER - 5/16"	8
17	138- 320	PIN - cotter 3/16" x 3/4"	1
18	C 16450	PIN - hair	1
19	C 20008	SPACER - axle 1/4"	1
20	111- 207	BOLT - 5/16" x 2" round head sq. neck	2
21	C 27231*	BRACKET - lift adaptor	1
22	113- 207*	BOLT - 3/8" - 16 x 1 grade 5	1
23	131- 1181*	NUT - 3/8" - 16 lock	1
24	C 25872	LINK - lift	1
25	C 25871	BOLT - "J" lift	1
26	141- 4	PIN - clevis 3/8"	1

* Required to mount K41 mower on tractors S/N and after:
 108 - 14031940
 110 - 14032840
 116 - all

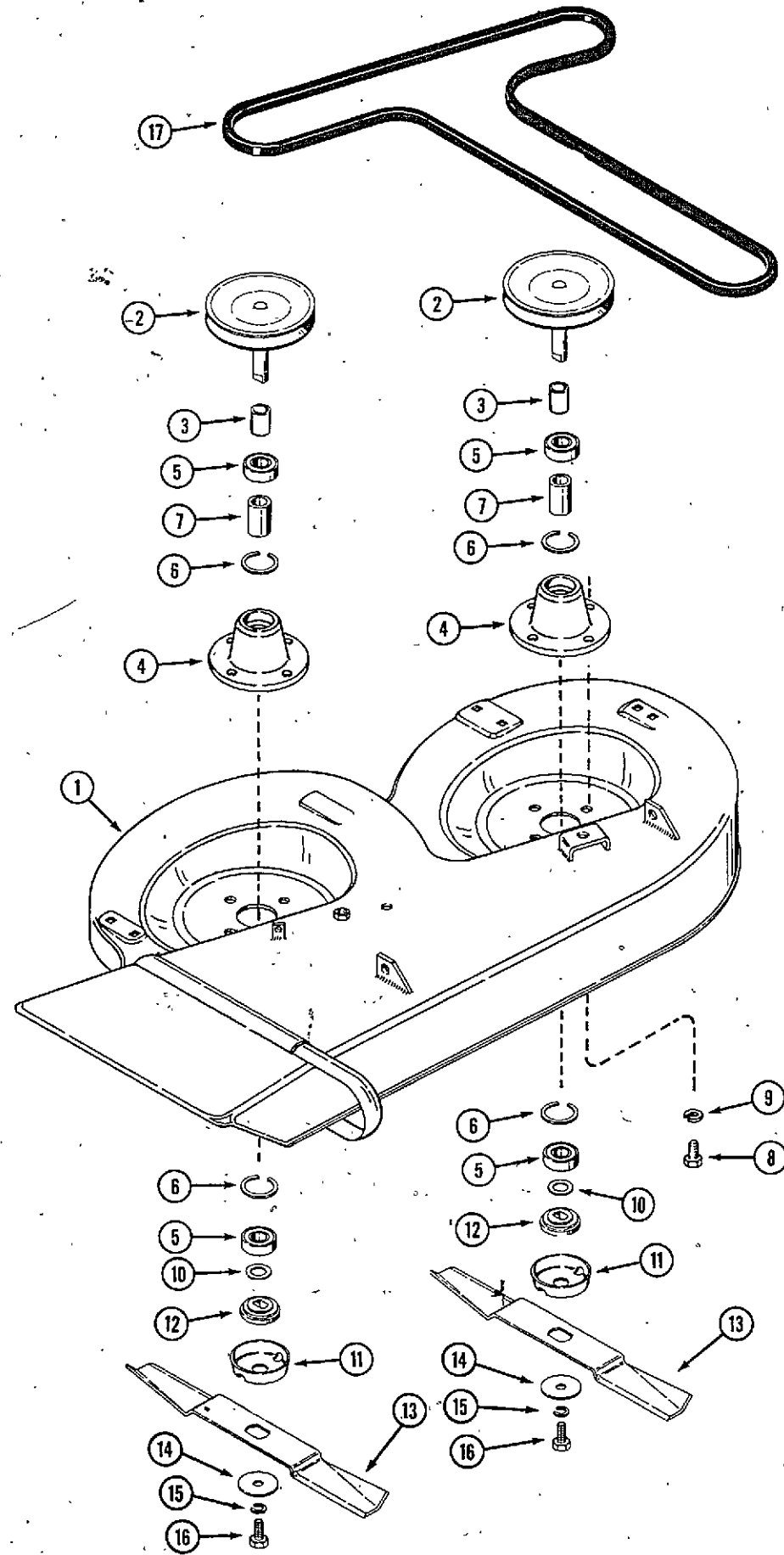

MODEL L41, M41, N41 ROTARY MOWER

DECK, BELT AND SPINDLE ASSEMBLY

REF.	PART NO.	DESCRIPTION	REQ'D.
1	C 26071	DECK - mower	1
2	C 26076	SPINDLE - mower	2
3	C 28276	SPACER - sleeve	2
4	C 17666	HOUSING - spindle (also requires [2] A63279 S/N EE 11122 and after)	2
5	C 28971	BEARING - spindle	4
6	C 16516	RING - retaining (service part)	4
7	C 10810	SPACER - bearing	2
8	113- 206	BOLT - 3/8" - 16 x 3/4"	8
9	192- 21	LOCKWASHER - 3/8"	8
10	C 25541	SPACER - washer	2
11	C 25544	SHIELD - bearing	2
12	C 25542	ADAPTOR - spindle	2
13	C 24797	BLADE - 17-1/4"	2
14	195- 2037	WASHER - 7/16" x 2"	2
15	192- 21	LOCKWASHER - 3/8"	2
16	113- 207	BOLT - 3/8" - 16 x 1"	2
16	113- 233	BOLT - 3/8" - 16 x 1-3/4"	2
17	C 26097	BELT - drive	1

WHEELS, AXLE AND IDLERS

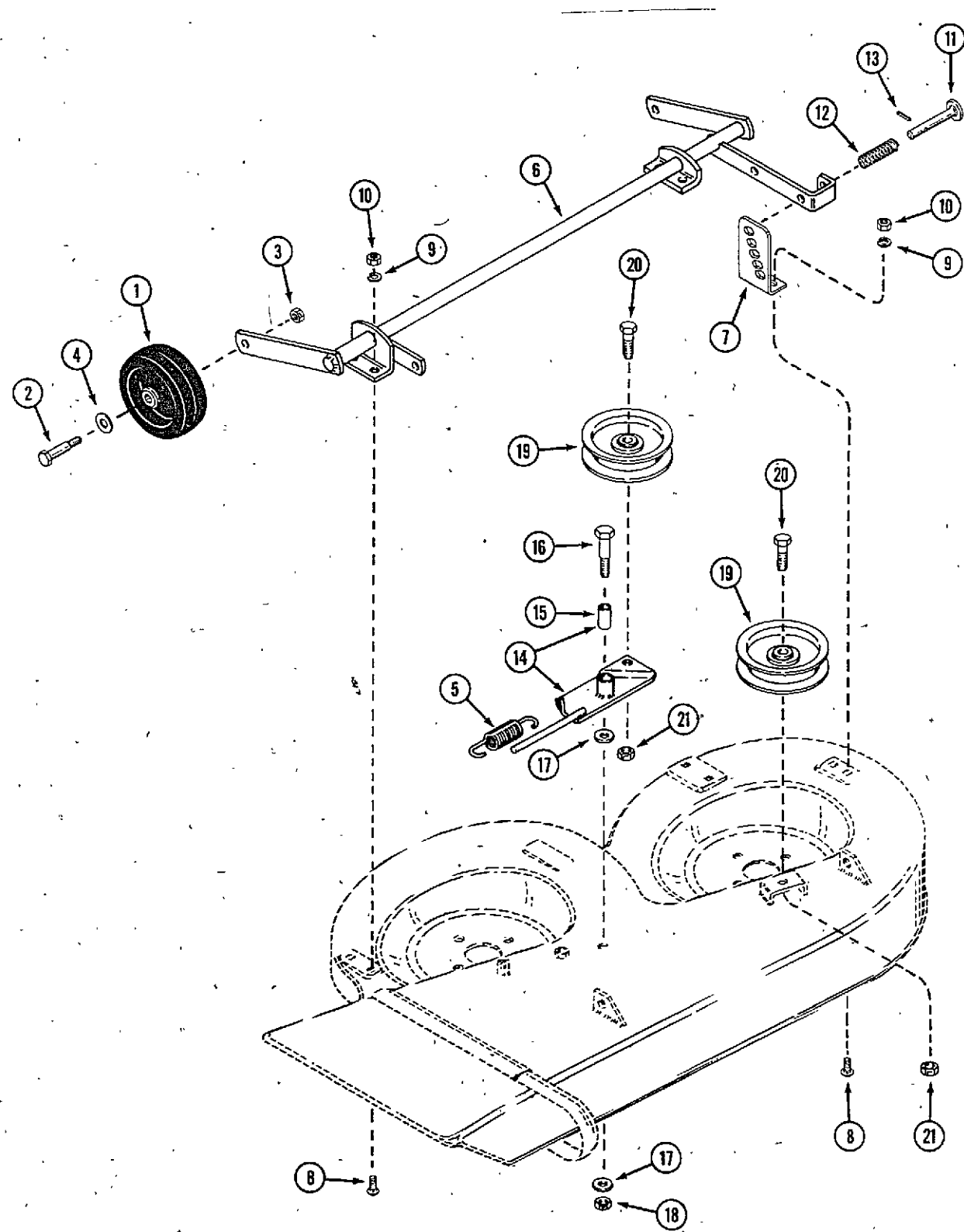

REF.	PART NO.	DESCRIPTION	REQ'D.
1	C 26736	WHEEL - gauge	2
2	C 16745	BOLT - shoulder	2
3	131- 1181	NUT - 3/8" lock	2
4	195- 533	WASHER - 1/2"	2
5	C 14482	SPRING - tension	1
6	C 26078	AXLE - mower	1
7	C 26086	BRACKET - height adjust	1
8	111- 132	BOLT - 5/16" - 18 x 3/4" carriage	6
9	192- 20	LOCKWASHER - 5/16"	6
10	129- 102	NUT - 5/16" - 18 hex	6
11	C 20005	PIN - height adjust	2
12	C 10482	SPRING - compression	2
13	138- 96	PIN - roll 3/16" x 1"	2
14	C 26087	ARM ASSEMBLY - idler	1
15	C 16714	BUSHING - sleeve	1
16	C 16745	BOLT - shoulder	1
17	195- 103	WASHER - 3/8"	2
18	131- 1181	NUT - lock 3/8" - 16	1
19	C 26090	PULLEY - flat	2
20	113- 410	BOLT - 1/2" - 13 x 1-1/2"	2
21	131- 1308	NUT - lock 1/2" - 13	2

MOUNTING AND LIFT ASSEMBLY

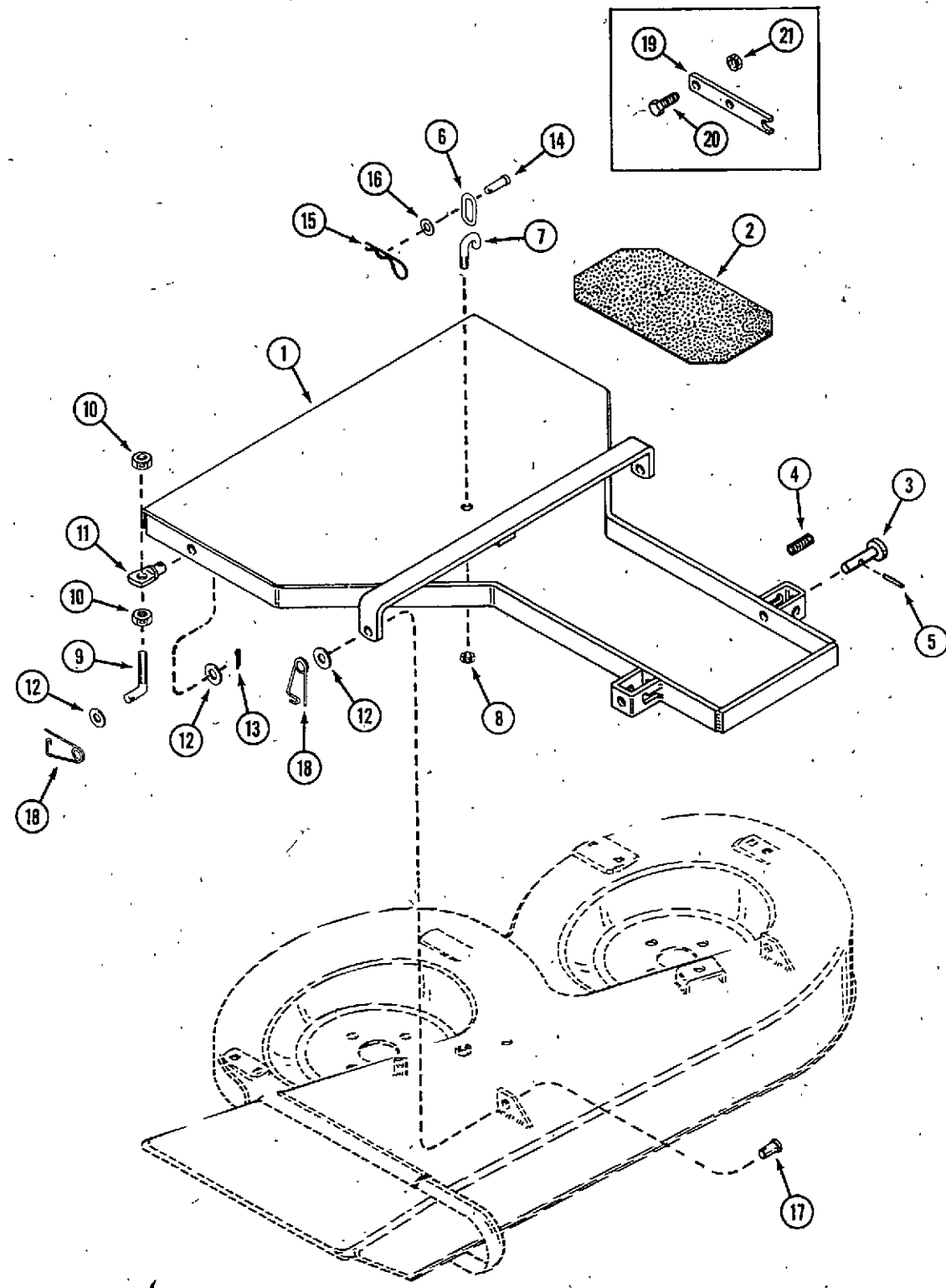

REF.	PART NO.	DESCRIPTION	REQ'D.
1	C 26093	FRAME - suspension	1
2	C 26092	PAD - foot	2
3	C 15278	PIN - latch	2
4	C 10482	SPRING - compression	2
5	138- 2073	PIN - roll 3/16" x 1-1/4"	2
6	C 25872	LINK - lift	1
7	C 25871	BOLT - "J", lift	1
8	131- 1181	NUT - lock 3/8" - 16 hex	1
9	C 19088	BOLT - "J" leveling	2
10	131- 1182	NUT - lock 1/2" - 13 hex	4
11	C 26033	LINK - adjust	2
12	195- 533	WASHER - 1/2"	6
13	132- 310	PIN - cotter 1/8" x 1"	2
14	141- 4	PIN - clevis 3/8"	1
15	C 16450	PIN - hair	1
16	195- 525	WASHER - 3/8"	1
17	C 10821	PIN - clevis 1/2"	2
18	C 10898	PIN - safety	4
19	C 27231*	BRACKET - lift adaptor (M41, N41)	1
20	113- 207*	BOLT - 3/8" - 16 x 1 grade 5	1
21	131- 1181*	NUT - lock 3/8" - 16	1

* Required to mount L41, M41, N41 mower on tractors S/N and after:
 108 - 14031940
 110 - 14032840
 116 - all

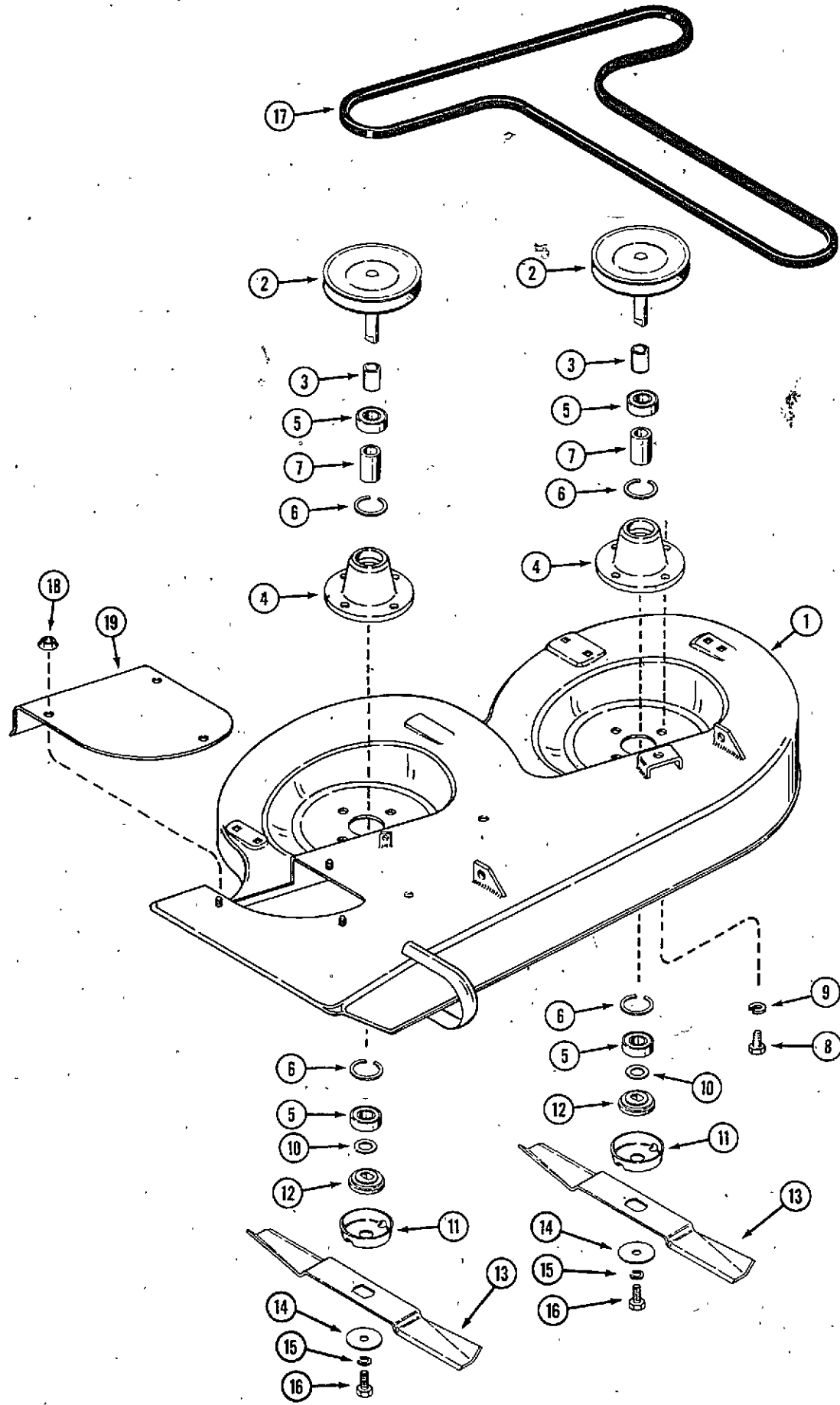

DECK, BELT AND SPINDLE ASSEMBLY

REF.	PART NO.	DESCRIPTION	REQ'D.
1	C 28477	DECK - mower	1
2	C 28481	SPINDLE - mower	2
3	C 28276	SPACER - sleeve	2
4	C 17668	HOUSING - spindle (also requires [2] A63279)	2
5	C 28971	BEARING - spindle	4
6	C 16516	RING - retaining (service part)	4
7	C 10810	SPACER - bearing	2
8	113- 206	BOLT - 3/8" - 16 x 3/4"	8
9	192- 21	LOCKWASHER - 3/8"	8
10	C 25541	SPACER - washer	2
11	C 25544	SHIELD - bearing	2
12	C 25542	ADAPTOR - spindle	2
13	C 28482	BLADE - 17-1/4"	2
14	195- 2037	WASHER - 7/16" x 2"	2
15	192- 21	LOCKWASHER - 3/8"	2
16	113- 233	BOLT - 3/8" - 16 x 1-3/4"	2
17	C 27023	BELT - drive	1
18	131- 931	NUT - 5/16" - 18 flanged	3
19	C 28483	COVER - chute	1

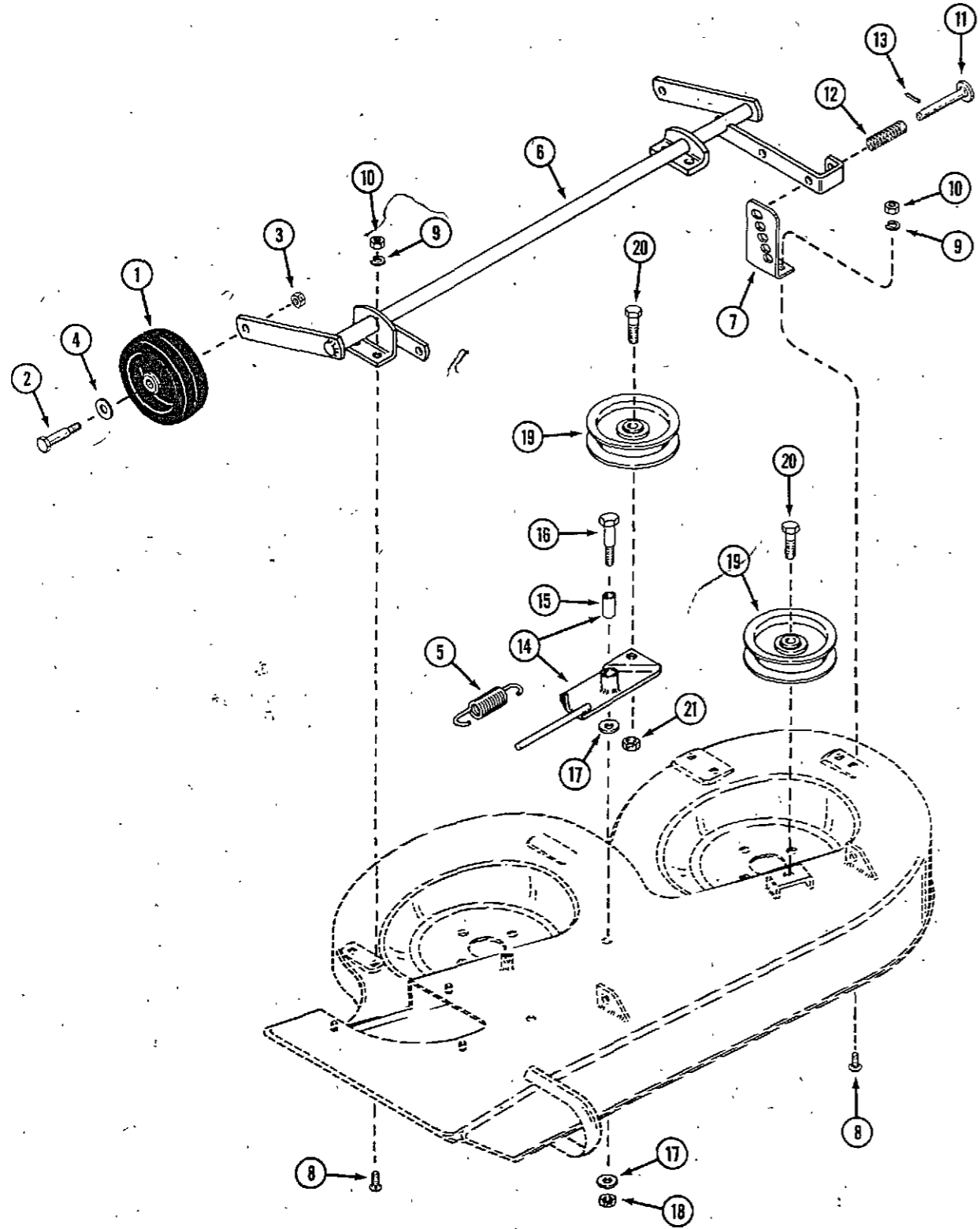

WHEELS, AXLE AND IDLERS

REF.	PART NO.	DESCRIPTION	REQ'D.
1	C 26736	WHEEL - gauge	2
2	C 16745	BOLT - shoulder	2
3	131- 1181	NUT - 3/8" lock	2
4	195- 533	WASHER - 1/2"	2
5	C 14482	SPRING - tension	1
6	C 26078	AXLE - mower	1
7	C 26086	BRACKET - height adjust	1
8	111- 132	BOLT - 5/16" - 18 x 3/4" carriage	6
9	192- 20	LOCKWASHER - 5/16"	6
10	129- 102	NUT - 5/16" - 18 hex	6
11	C 20005	PIN - height adjust	2
12	C 10482	SPRING - compression	2
13	138- 96	PIN - roll 3/16" x 1"	2
14	C 26087	ARM ASSEMBLY - idler	1
15	C 16714	BUSHING - sleeve	1
16	C 16745	BOLT - shoulder	1
17	195- 103	WASHER - 3/8"	2
18	131- 1181	NUT - lock 3/8" - 16	1
19	C 26090	PULLEY - flat	2
20	113- 410	BOLT - 1/2" - 13 x 1-1/2"	2
21	131- 1308	NUT - lock 1/2" - 13	1

MOUNTING AND LIFT ASSEMBLY

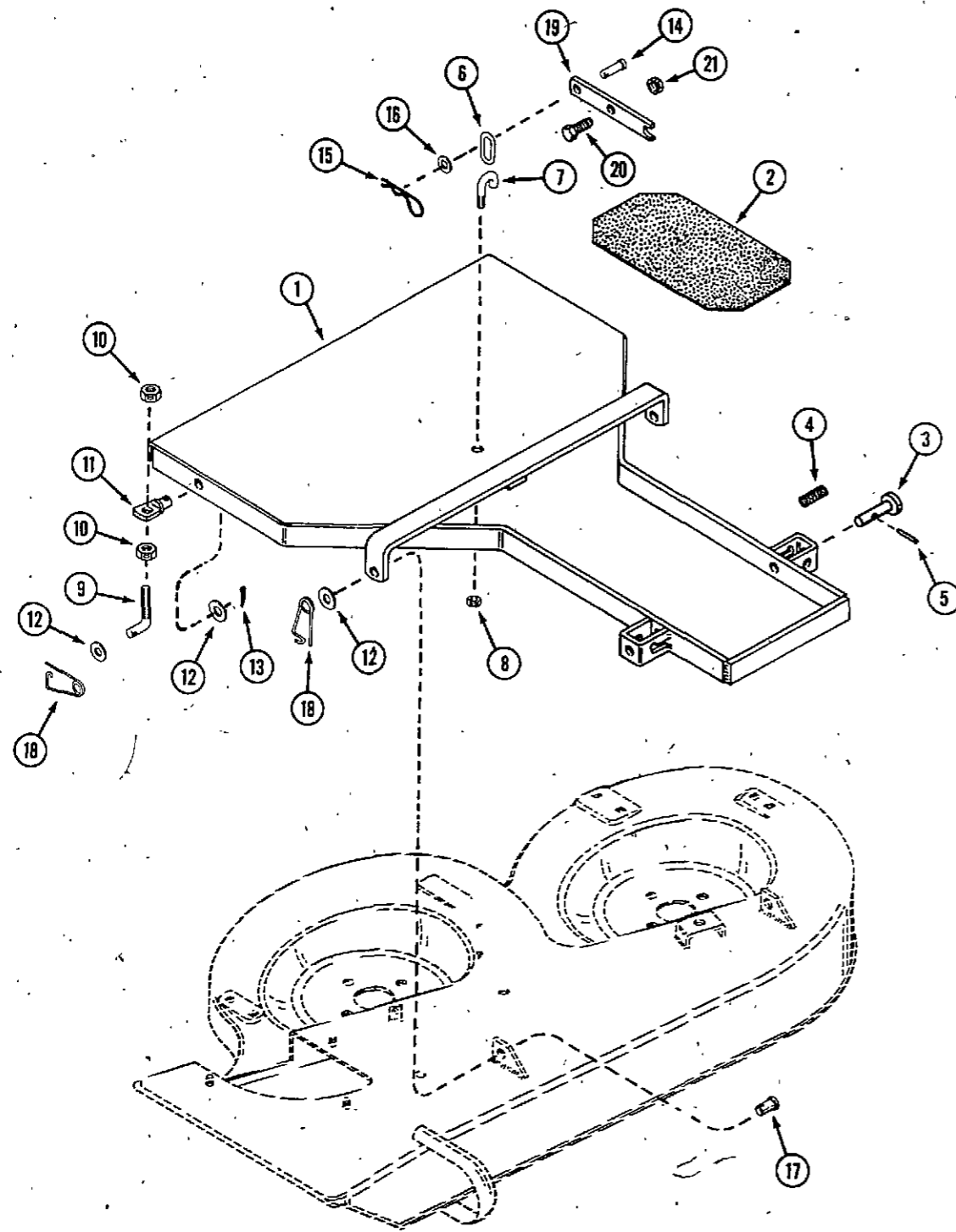

REF.	PART NO.	DESCRIPTION	REQ'D.
1	C 26093	FRAME - suspension	1
2	C 26092	PAD - foot	2
3	C 15278	PIN - latch	2
4	C 10482	SPRING - compression	2
5	138- 2073	PIN - roll 3/16" x 1-1/4"	2
6	C 25872	LINK - lift	2
7	C 25871	BOLT - "J", lift	1
8	131- 1181	NUT - lock 3/8" - 16 hex	1
9	C 19088	BOLT - "J" leveling	1
10	131- 1182	NUT - lock 1/2" - 13 hex	2
11	C 26033	LINK - adjust	4
12	195- 533	WASHER - 1/2"	2
13	132- 310	PIN - cotter 1/8" x 1"	6
14	141- 4	PIN - clevis 3/8"	2
15	C 16450	PIN - hair	1
16	195- 525	WASHER - 3/8"	1
17	C 10821	PIN - clevis 1/2"	1
18	C 10898	PIN - safety	2
19	C 27231*	BRACKET - lift adaptor	4
20	113- 207*	BOLT - 3/8" - 16 x 1 grade 5	1
21	131- 1181*	NUT - lock 3/8" - 16	1

* Required to mount mower on tractors S/N and after:
 108 - 14031940
 110 - 14032840
 116 - all

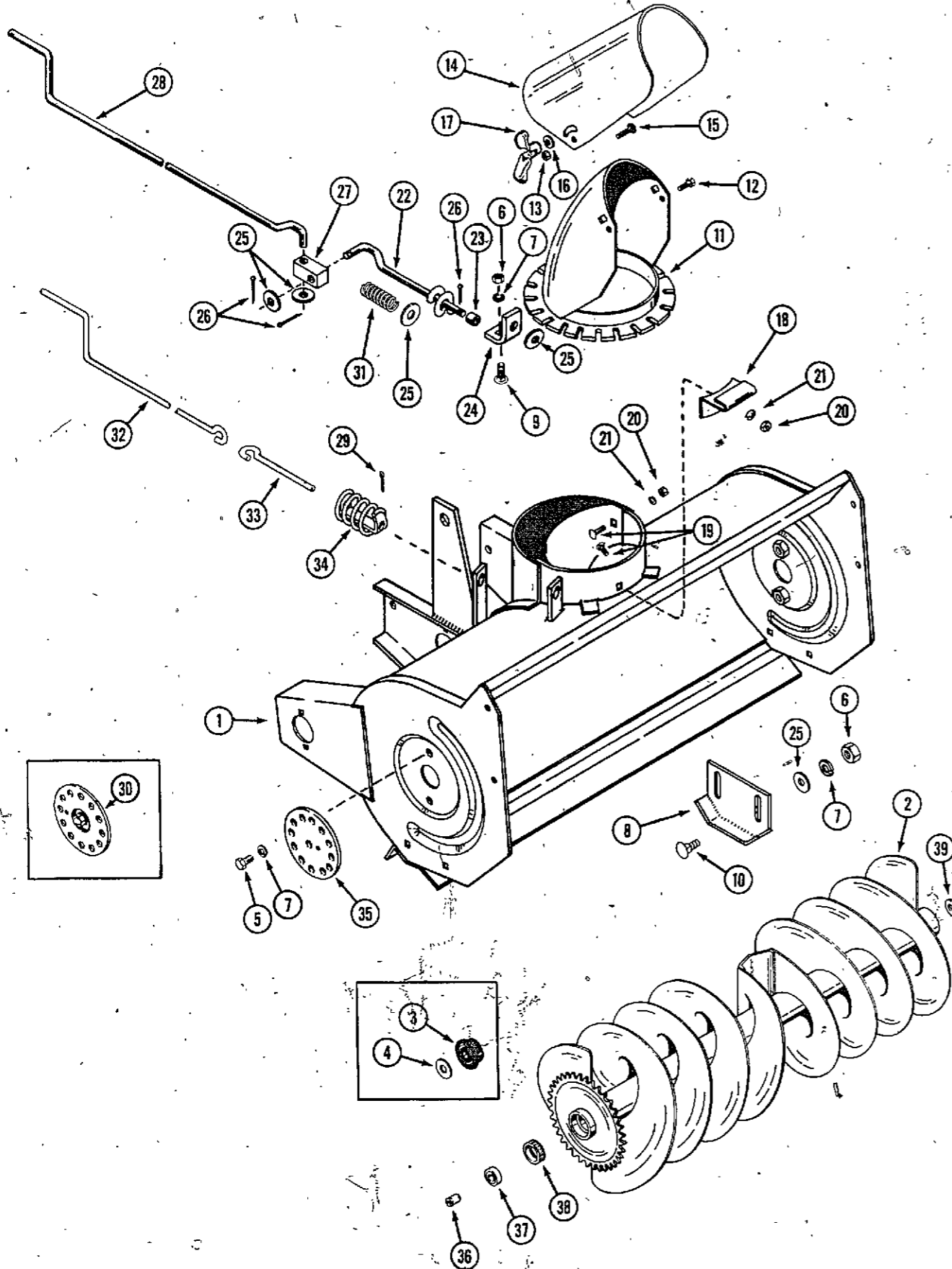

AUGER AND CHUTE ASSEMBLY

REF.	PART NO.	DESCRIPTION	REQ'D.
1	NSS	HOUSING - auger 32" (J81) (order C25183, C24705, C24643, C24640 and 132-300)	1
1	C 25183	HOUSING - auger 32" (J81)	1
2	C 25206	AUGER - includes items 36, 37 and 38 (M81)	1
2	C 15297	AUGER - (J, K, L81)	1
3	C 14421	BEARING - auger (J, K, L81)	2
4	195- 545	WASHER - 3/4" (J, K, L81)	UAR
5	113- 206	BOLT - 3/8" NC x 3/4" hex	4
6	129- 103	NUT - 3/8" NC hex	5
7	192- 21	LOCKWASHER - 3/8"	9
8	C 17775	SKID	2
9	111- 302	BOLT - 3/8" NC x 3/4" rd. hd. square neck (J81)	1
10	111- 371	BOLT - 3/8" NC x 1" rd. hd. square neck	4
11	C 15248	CHUTE	1
12	113- 1	BOLT - 1/4" NC x 1/2" hex	2
13	131- 1102	LOCKNUT - 1/4" NC hex	2
14	C 16940	DEFLECTOR	1
15	111- 340	BOLT - 3/8" NC x 3/4" rd. hd. square neck	2
16	C 28263	WASHER - dished 25/64" x 1"	2
17	C 22774	WING NUT - deflector lock	2
18	C 15334	BRACKET - chute hold down	3
19	111- 202	BOLT - 5/16" NC x 3/4" rd. hd. square neck	2
20	129- 102	NUT - 5/16" NC hex	2
21	192- 20	LOCKWASHER - 5/16"	3
22	C 15244	ROD - chute control (J81)	1
23	C 15277	SPACER - rod, chute control (J81)	1
24	C 15240	BRACKET - control rod (J81)	1
25	195- 525	WASHER - 3/8" plain	8
26	132- 320	PIN - cotter 3/32" x 3/4" (J81)	3
27	C 14583	JOINT - block (J81)	1
28	C 15371	CRANK - chute control (J81)	1
29	132- 310	PIN - cotter 1/8" x 1" (K, L, M81)	1
30	C 19734	PLATE - stub shaft (J, K, L81)	2
31	C 17612	SPRING - compression (J81)	1
32	C 24705	CRANK - chute control (K, L, M81)	1
33	C 24643	ROD - chute control (K, L, M81)	1
34	C 24640	COIL - chute control (K, L, M81)	1
35	C 25842	HUB - auger (M81)	2
36	C 25841	SHAFT - stub (M81)	2
37	C 28971	BEARING - auger (M81)	2
38	C 25840	SLEEVE - bearing (M81)	2
39	195- 522	WASHER - spacer (M81)	UAR

AUGER AND CHUTE ASSEMBLY

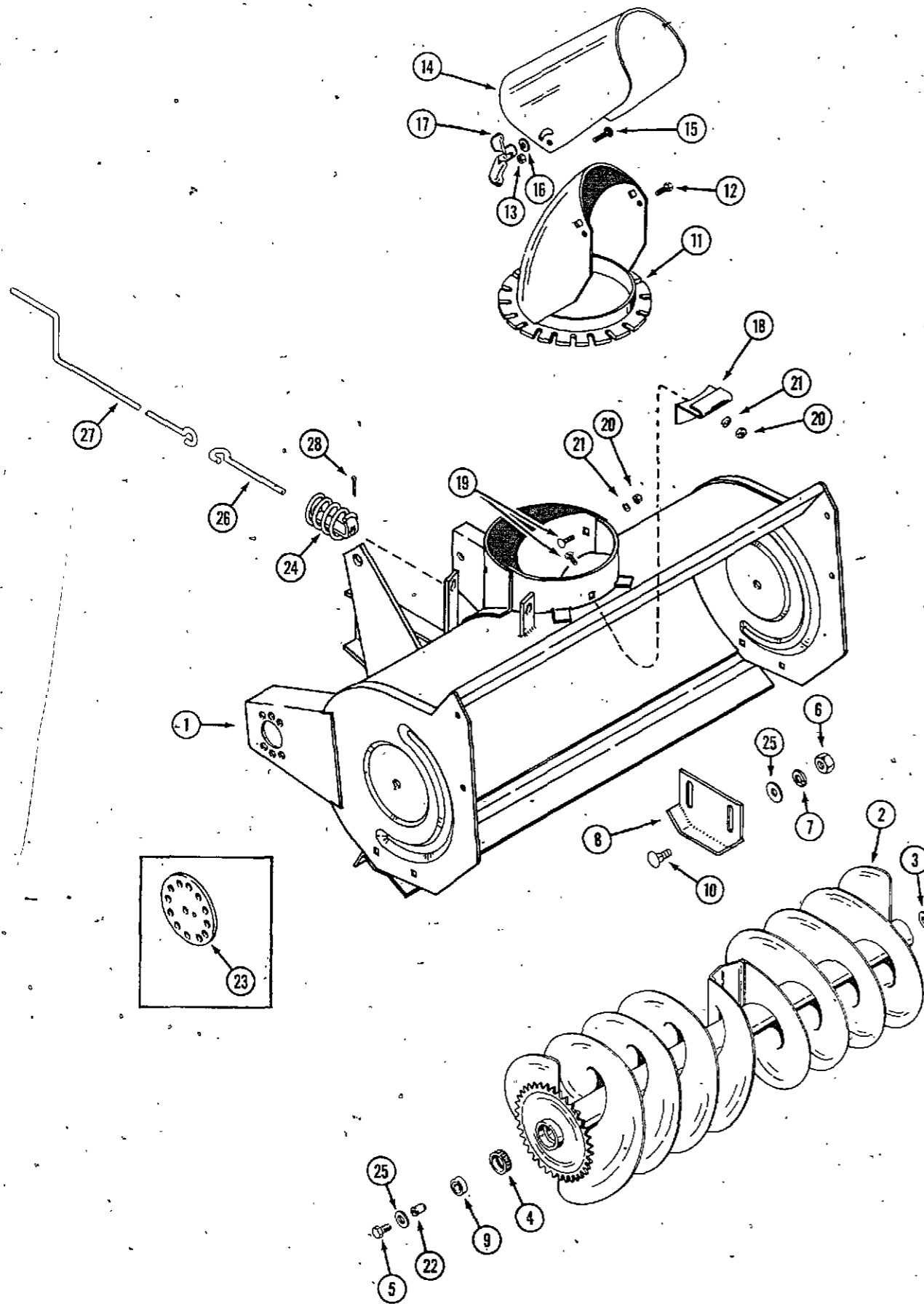

REF.	PART NO.	DESCRIPTION	REQ'D.
1	C 27087	HOUSING - auger 32" (P81, R81) shown	1
1	NSS	HOUSING - auger 32" (N81) use C27087 and (2) 113-102	1
2	C 25206	AUGER - includes items 4, 9 and 22	1
3	195- 522	WASHER - spacer	1
4	C 25840	SLEEVE - bearing	2
5	113- 207	BOLT - 3/8" NC x 1" hex (use lock tite for installation)	2
6	129- 103	NUT - 3/8" NC hex	4
7	192- 21	LOCKWASHER - 3/8"	4
8	C 17775	SKID	2
9	C 28971	BEARING - auger	1
10	111- 371	BOLT - 3/8" NC x 1" rd. hd. square neck	4
11	C 15248	CHUTE	1
12	113- 1	BOLT - 1/4" NC x 1/2" hex	2
13	131- 1102	LOCKNUT - 1/4" NC hex	2
14	C 16940	DEFLECTOR	1
15	111- 340	BOLT - 3/8" NC x 3/4" rd. hd. square neck	2
16	C 28263	WASHER - dished 25/64" x 1"	2
17	C 22774	WING NUT - deflector lock	2
18	C 15334	BRACKET - chute hold down	3
19	111- 202	BOLT - 5/16" NC x 3/4" rd. hd. square neck	2
20	129- 102	NUT - 5/16" NC hex	2
21	192- 20	LOCKWASHER - 5/16"	3
22	C 25841	SHAFT - stub	2
23	C 25842	HUB - auger (N81)	1
24	C 24640	COIL - chute control	1
25	195- 525	WASHER - 3/8" plain	6
26	C 24643	ROD - chute control	1
27	C 24705	CRANK - chute control	1
28	132- 310	PIN - cotter 1/8" x 1"	1

MOUNTING COMPONENTS AND DRIVE ASSEMBLY

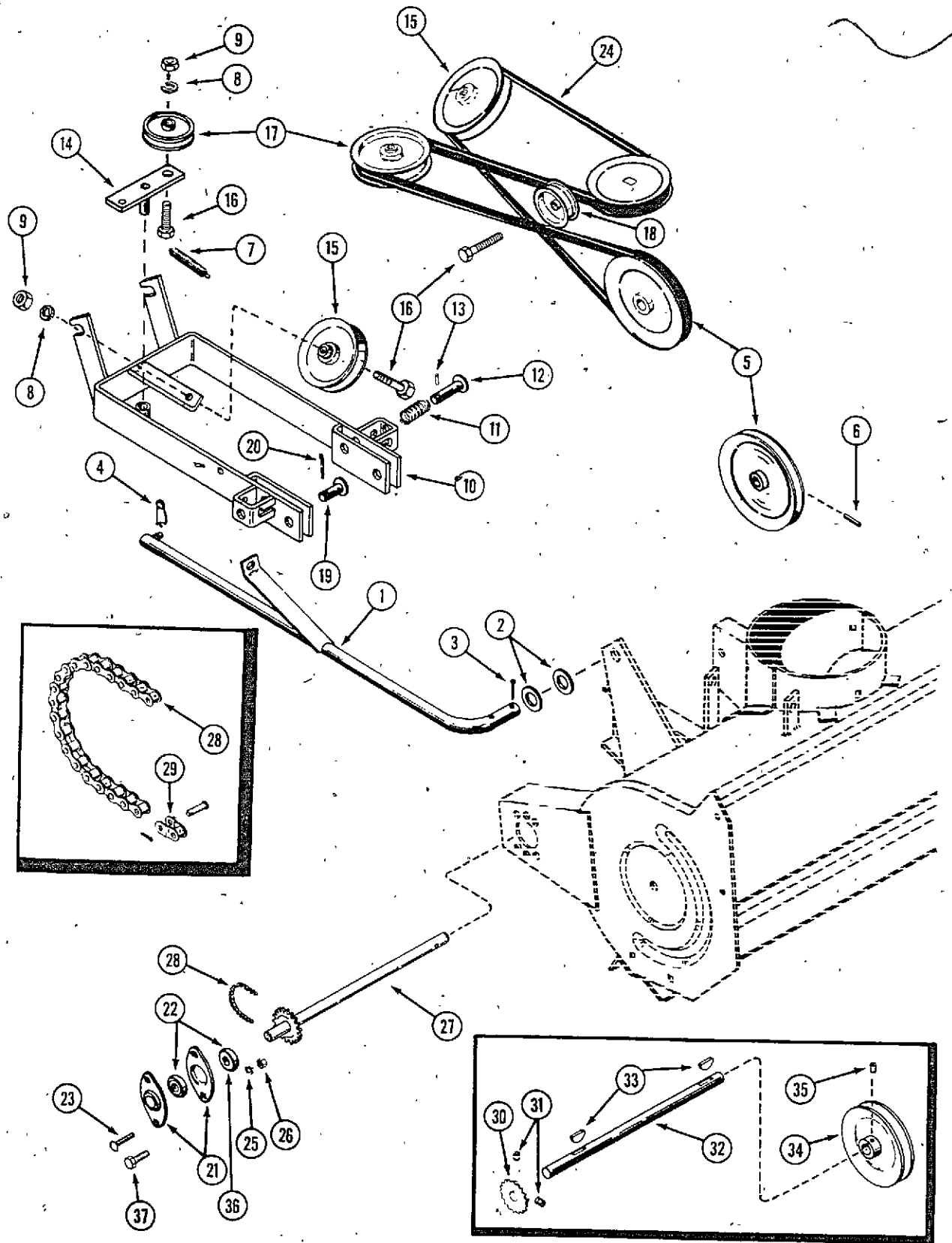

REF.	PART NO.	DESCRIPTION	REQ'D.
1	C 15375	ROD - lift (J81, K81, L81, M81) shown	1
1	C 27085	ROD - lift (N81, P81, R81)	1
2	195- 549	WASHER - 7/8" ZP	2
3	132- 332	PIN - cotter 3/32" x 1-1/2"	2
4	C 10898	PIN - safety	1
5	C 19824	PULLEY - 6" (J81, K81)	1
5	C 19731	PULLEY - 6" (L81, M81, N81, P81, R81)	1
6	138- 2073	PIN - roll 3/16" x 1-1/4" (J81, K81)	1
6	138- 2040	PIN - roll 1/4" x 1-1/2" (L81, M81, N81, P81, R81)	1
7	C 15671	SPRING - idler arm	1
8	192- 21	LOCKWASHER - 3/8" ZP	3
9	129- 103	NUT - 3/8" NC hex, ZP	3
10	C 15288	BRACKET - mounting	1
11	C 10482	SPRING	1
12	C 15278	PIN - latch	2
13	138- 2073	PIN - roll 3/16" x 1-1/4"	2
14	C 15296	ARM - idler	1
15	C 15329	PULLEY - idler	1
16	113- 219	BOLT - 3/8" x 2" NC hex	3
17	C 15343	PULLEY - idler 4-1/2"	1
18	C 15672	PULLEY - idler 2-1/2"	1
19	141- 56	PIN - clevis 1/2"	2
20	132- 310	PIN - cotter 1/8" x 1"	2
21	C 15386	FLANGETTE - (J81 and K81)	4
21	C 28277	FLANGETTE - (L81, M81, N81, P81, R81)	4
22	C 28871	BEARING - 3/4" (L81, M81, N81, P81, R81)	2
22	C 15385	BEARING - includes collar and setscrew (J81 and K81)	2
23	111- 108	BOLT - 1/4" x 3/4" NC rd. hd. square neck (J81, K81)	4
23	111- 202	BOLT - 5/16" - 18 x 3/4" carriage (L81, M81, N81, P81, R81)	2
24	C 23950	BELT - drive	1
25	192- 19	LOCKWASHER - 1/4" ZP (J81, K81)	4
25	192- 20	LOCKWASHER - 5/16" (L81, M81, N81, P81, R81)	4
26	129- 101	NUT - 1/4" NC hex, ZP (J81, K81)	4
26	129- 102	NUT - 5/16" - 18 (L81, M81, N81, P81, R81)	4
27	C 19821	SHAFT ASSEMBLY - drive (J81, K81)	1
27	C 25186	SHAFT ASSEMBLY - drive (L81, M81, N81, P81, R81)	1
28	C 18775	CHAIN - auger drive, 82 pitches, #35 roller chain	1
29	C 28805	LINK - offset, #35 roller chain	2
	C 28645	CONNECTOR LINK - #35	1
30	C 15330	SPROCKET - 18T (includes setscrew) used prior to S/N H30473	1
31	83- 44	SETSCREW - 1/4" NC socket head	2
32	C 15331	SHAFT - drive (used prior to S/N H30473)	1
33	126- 16	KEY - 3/16" x 3/4"	2
34	C 15293	PULLEY - 6" (used prior to S/N H30473)	1
35	178- 858	SETSCREW - 5/16" x 3/8" NC socket head cup point	1
36	C 29024	COLLAR - locking (L81, M81, N81, P81, R81)	2
37	113- 102	BOLT - 5/16" - 18 x 3/4"	2

USED PRIOR TO S/N H30473

UTILITY BLADE

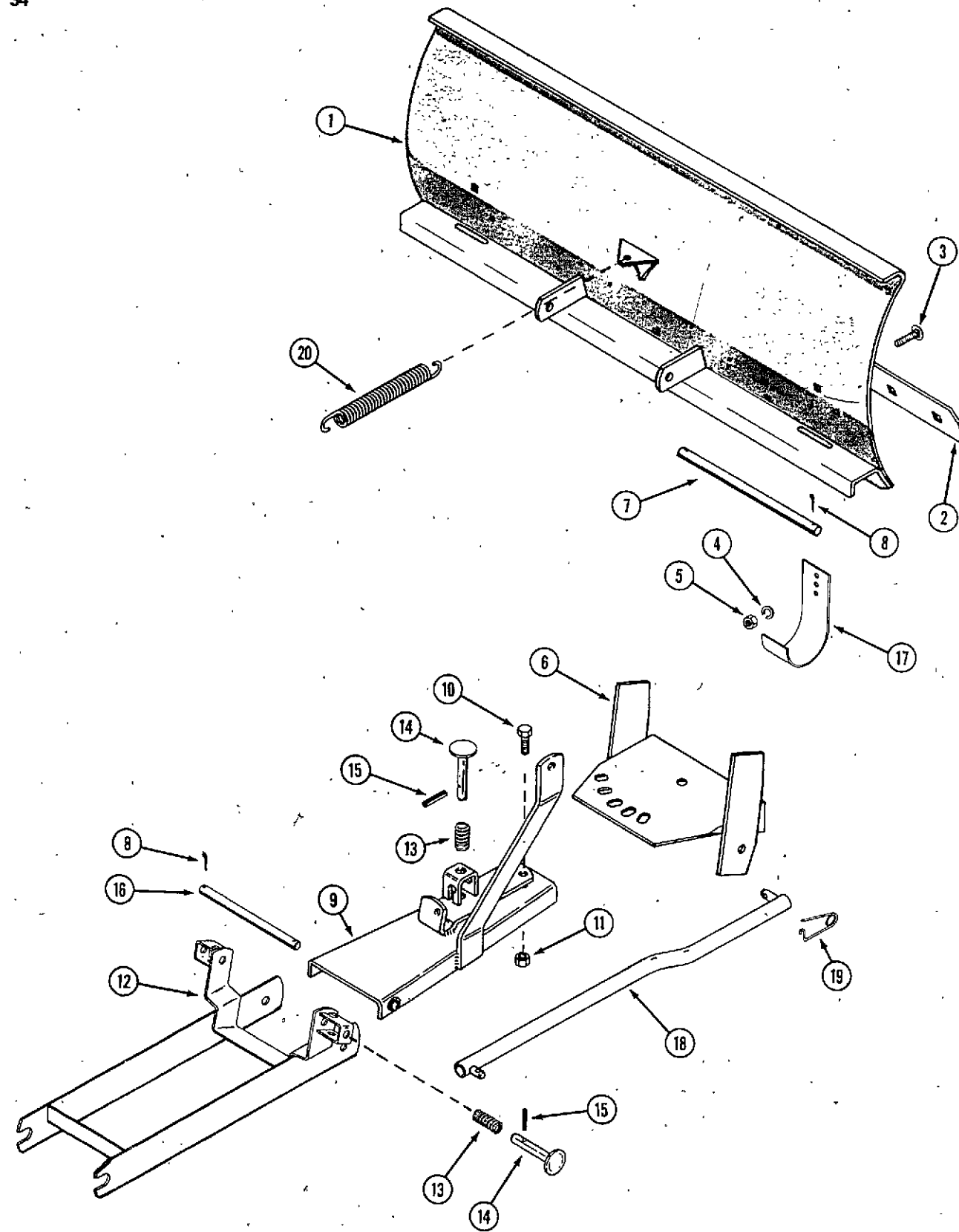

REF.	PART NO.	DESCRIPTION	REQ'D.
1	C 15461	BLADE ASSEMBLY - 38"	1
2	C 15462	EDGE - cutting	1
3	111- 203	BOLT - 5/16" x 1" NC round head, square neck	10
4	192- 20	LOCKWASHER - 5/16"	10
5	129- 102	NUT - 5/16" NC hex	10
6	C 15494	PIVOT - blade	1
7	C 15495	PIN - blade pivot	1
8	132- 310	PIN - cotter 1/8" x 1"	4
9	N S S	BRACKET - push (G51) use C27080 and C27083	1
9	C 27080	BRACKET - push (H51, J51) shown	1
10	113- 417	BOLT - 1/2" x 1-1/4" NC hex	1
11	131- 165	NUT - 1/2" NC hex	1
12	C 15463	BRACKET - mounting	1
13	C 10482	SPRING - compression	3
14	C 15278	PIN - latch	3
15	138- 99	PIN - roll 3/16" x 1-3/8"	3
16	C 15496	PIN - bracket pivot	1
17	C 15469	SHOE - skid	2
18	C 15497	ROD - lift (G51)	1
18	C 27083	PIPE - lift (H51, J51) shown	1
19	C 10898	PIN - safety	2
20	C 27779	SPRING - blade extension	1

BAGGER

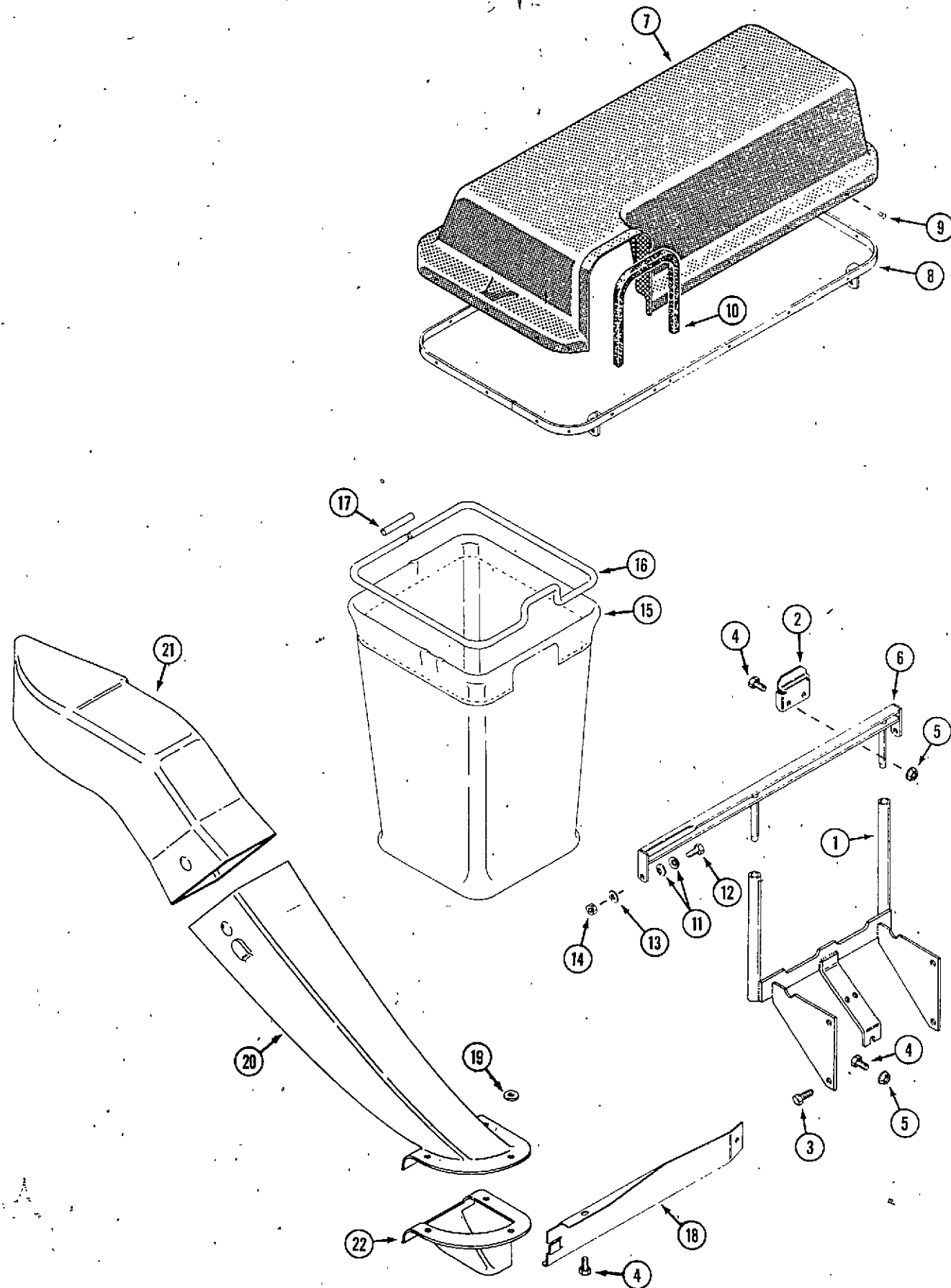

REF.	PART NO.	DESCRIPTION	REQ'D.
1	C 28429	BRACKET - mounting	1
2	C 28436	BRACKET - retaining, hopper	2
3	113- 207	BOLT - 3/8" x 1"	4
4	113- 102	BOLT - 5/16" x 3/4"	7
5	131- 911	NUT - 5/16" flanged	6
6	C 28434	FRAME - support	1
7	C 24685	COVER - bagger	1
8	C 24494	HINGE - cover	1
9	151- 88	RIVET - 3/16" x 5/16"	17
10	C 24610	SEAL - chute	1
11	C 25114	SPRING WASHER - Belleville	4
12	113- 103	BOLT - 5/16" - 18 x 1"	2
13	195- 521	WASHER - 5/16"	2
14	131- 176	NUT - 5/16 - 18 lock	2
15	C 28438	HOPPER	2
16	C 28439	REINFORCEMENT - metal	2
17	C 28440	TUBE - retaining	2
18	C 28446	BAFFLE - mower	1
19	195- 521	WASHER - 5/16"	3
20	C 28441	CHUTE - lower	1
21	C 28448	CHUTE - upper	1
22	C 29038	BOOT - mower	1

INGERSOLL ⁸ hi cast ⁵ 32

⁷ **38**

³ ¹⁷ **hi cast 32**

! DANGER

SPINNING BLADE
KEEP CLEAR
CONTACT CAN INJURE

¹¹

! WARNING

ROTATING AUGER
TO AVOID SEVERE INJURY,
KEEP HANDS OUT OF AUGER AND DISCHARGE
CHUTE WHILE ENGINE IS RUNNING

¹

! WARNING

FLYING DEBRIS
OPERATE MOWER ONLY
WITH DISCHARGE CHUTE
GUARD/COVER OR COMPLETE
GRASS CATCHER IN PLACE.
DEBRIS MAY CAUSE INJURY

¹²

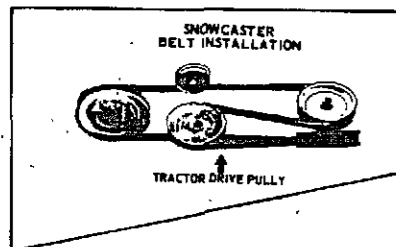

²

! CAUTION

FLYING DEBRIS
1. DO NOT RAISE COVER WHILE OPERATING.
2. PROPERLY INSTALL BAGGER AND CHUTE
BEFORE STARTING MOWER. SEE OPER-
ATOR'S MANUAL FOR FURTHER
INSTRUCTIONS.

¹⁰

! CAUTION

KEEP HANDS AND FEET
CLEAR OF THIS AREA
BLADE TILTS WITH
SPRING TRIP ACTION
PINCH POINTS
COULD CAUSE
PERSONAL INJURY

¹³

38

¹⁴

CASE

⁹

CASE

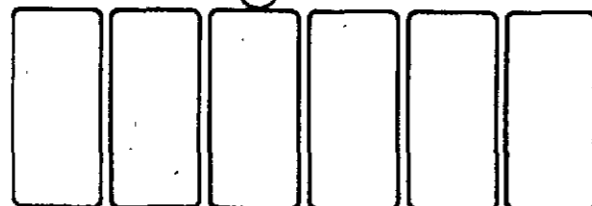

DECALS

REF.	PART NO.	DESCRIPTION	REQ'D.
1	321- 4199	DECAL - "Rotating Auger" (all casters)	1
2	C 16102	DECAL - drive belt (all casters)	1
3	C 27198	DECAL - "Hi Cast" (N81, P81)	1
4	321- 6379	DECAL - "CASE"	1
5	C 27937	DECAL - "Hi Cast" (R81)	1
6	NSS	DECAL - "CASE" (Use 321-6379)	1
7	C 27972	DECAL - stripe (cut to length)	1
8	C 27973	DECAL - "INGERSOLL"	1
9	321- 6380	DECAL - white tread (M81)	UAR
10	321- 6433	DECAL - cutting height (all mowers)	1
11	321- 4381	DECAL - "Spinning Blade" (all mowers)	1
12	C 28428	DECAL - "Flying Debris" (P41, R41, B06)	1
13	321- 4686	DECAL - "Pinch Points" (all blades)	1
14	C 27940	DECAL - 38" (J51)	1
15	321- 4447	DECAL - "Spinning Blade" (B96)	1
16	321- 4446	DECAL - "Flying Debris" (B96)	1
17	C 27201	DECAL - utility blade (H51)	1

DECALS (French)

1	321- 4757	DÉCAL - "Rotating Auger" (all casters)	1
2	321- 4753	DÉCAL - drive belt (all casters)	1
11	321- 4763	DÉCAL - "Spinning Blade" (all mowers)	1
15	321- 4750	DÉCAL - "Spinning Blade" (B96)	1
16	321- 4761	DÉCAL - "Flying Debris" (B96)	1

NUMERICAL INDEX

PART NO.	PAGE NO.	REF. NO.	PART NO.	PAGE NO.	REF. NO.	PART NO.	PAGE NO.	REF. NO.			
C	10482	7	21	C	15494	35	6	C	19731	33	5
C	10482	9	3	C	15495	35	7	C	19734	29	30
C	10482	13	21	C	15496	35	16	C	19821	33	27
C	10482	15	3	C	15497	35	18	C	19824	33	5
C	10482	19	12	C	15618	7	20	C	20005	13	22
C	10482	21	4	C	15671	33	7	C	20005	19	11
C	10482	25	12	C	15677	7	12	C	20005	25	11
C	10482	27	4	C	15677	13	12	C	20006	9	9
C	10482	33	11	C	15942	7	22	C	20006	15	9
C	10482	35	13	C	16077	7	14	C	20007	15	13
C	10810	17	7	C	16102	39	2	C	20008	15	19
C	10810	23	7	C	16450	9	18	C	20009	11	16
C	10821	21	17	C	16450	15	18	C	20013	13	11
C	10821	27	17	C	16450	21	15	C	20016	13	3
C	10898	9	7	C	16450	27	15	C	20017	13	8
C	10898	15	7	C	16516	17	6	C	21519	11	17
C	10898	21	18	C	16516	23	6	C	22774	29	17
C	10898	27	18	C	16714	7	2	C	22774	31	17
C	10898	33	4	C	16714	13	2	C	23535	33	18
C	10898	35	19	C	16714	19	15	C	23950	33	24
C	10942	11	3	C	16714	25	15	C	24494	37	8
C	14421	29	3	C	16719	5	6	C	24610	37	10
C	14482	19	5	C	16745	7	1	C	24640	29	34
C	14482	25	5	C	16745	7	24	C	24640	31	24
C	14583	29	27	C	16745	13	1	C	24643	29	33
C	14966	7	25	C	16745	19	2	C	24643	31	26
C	15240	29	24	C	16745	19	16	C	24685	37	7
C	15244	29	22	C	16745	25	2	C	24705	29	32
C	15248	29	11	C	16745	25	16	C	24705	31	27
C	15248	31	11	C	16940	29	14	C	24797	5	8
C	15272	5	3	C	16940	31	14	C	24797	11	8
C	15277	29	23	C	17083	5	12	C	24797	17	13
C	15278	9	2	C	17083	11	6	C	25114	37	11
C	15278	15	2	C	17083	11	12	C	25183	29	1
C	15278	21	3	C	17155	5	2	C	25186	33	27
C	15278	27	3	C	17155	11	2	C	25206	29	2
C	15278	33	12	C	17274	7	6	C	25206	31	2
C	15278	35	14	C	17274	13	6	C	25541	17	10
C	15288	33	10	C	17612	29	31	C	25541	23	10
C	15293	33	34	C	17666	17	4	C	25542	11	7
C	15296	33	14	C	17666	23	4	C	25542	17	12
C	15297	29	2	C	17761	7	11	C	25542	23	12
C	15329	33	15	C	17775	29	8	C	25544	11	18
C	15330	33	30	C	17775	31	8	C	25544	17	11
C	15331	33	32	C	18029	15	12	C	25544	23	11
C	15334	29	18	C	18775	33	28	C	25840	29	38
C	15334	31	18	C	18899	7	13	C	25840	31	4
C	15343	33	17	C	18905	5	1	C	25841	29	36
C	15351	9	12	C	19084	7	3	C	25841	31	22
C	15352	9	13	C	19088	9	5	C	25842	29	35
C	15371	29	28	C	19088	15	5	C	25842	31	23
C	15375	33	1	C	19088	21	9	C	25871	15	25
C	15385	33	22	C	19088	27	9	C	25871	21	7
C	15386	33	21	C	19259	13	14	C	25871	27	7
C	15461	35	1	C	19273	13	13	C	25872	15	24
C	15462	35	2	C	19456	9	1	C	25872	21	6
C	15463	35	12	C	19456	15	1	C	25872	27	6
C	15469	35	17	C	19457	11	1	C	26033	21	11

NUMERICAL INDEX

PART NO.	PAGE NO.	REF. NO.	PART NO.	PAGE NO.	REF. NO.	PART NO.	PAGE NO.	REF. NO.			
C	26033	27	11	C	28971	11	5	129-	101	33	26
C	26071	17	1	C	28971	17	5	129-	102	7	16
C	26076	17	2	C	28971	23	5	129-	102	9	15
C	26078	19	6	C	28971	29	37	129-	102	13	16
C	26078	25	6	C	28971	31	9	129-	102	15	15
C	26086	19	7	C	28972	5	4	129-	102	19	10
C	26086	25	7	C	28972	11	4	129-	102	25	10
C	26087	19	14	C	29024	33	36	129-	102	29	20
C	26087	25	14	C	29038	37	22	129-	102	31	20
C	26090	19	19					129-	102	33	26
C	26090	25	19					129-	102	35	5
C	26092	21	2					129-	103	7	10
C	26092	27	2					129-	103	11	15
C	26093	21	1					129-	103	13	10
C	26093	27	1					129-	103	29	6
C	26097	17	17					129-	103	31	6
C	26736	19	1					129-	103	33	9
C	26736	25	1					131-	165	35	11
C	26736	7	23					131-	176	37	14
C	26736	13	19					131-	178	7	5
C	27023	23	17					131-	911	37	5
C	27080	35	9					131-	931	23	18
C	27083	35	18					131-	1100	9	6
C	27085	33	1					131-	1181	9	21
C	27087	31	1					131-	1181	13	5
C	27198	39	3					131-	1181	15	6
C	27201	39	17					131-	1181	15	23
C	27231	9	19					131-	1181	19	3
C	27231	15	21					131-	1181	19	18
C	27231	21	19					131-	1181	21	8
C	27231	27	19					131-	1181	21	21
C	27779	35	20					131-	1181	25	3
C	27937	39	5					131-	1181	25	18
C	27940	39	14					131-	1181	27	8
C	27972	39	7					131-	1181	27	21
C	27973	39	8					131-	1182	21	10
C	28263	29	16					131-	1182	27	10
C	28263	31	16					131-	1182	27	10
C	28276	17	3					131-	1102	29	13
C	28276	23	3					131-	1102	31	13
C	28277	33	21					131-	1308	19	21
C	28428	39	12					131-	1308	25	21
C	28429	37	1					132-	310	21	13
C	28434	37	6					132-	310	27	13
C	28436	37	2					132-	310	29	29
C	28438	37	15					132-	310	31	28
C	28439	37	16					132-	310	33	20
C	28440	37	17					132-	310	35	8
C	28441	37	20					132-	320	29	26
C	28446	37	18					132-	332	33	3
C	28448	37	21					138-	77	7	19
C	28477	23	1					138-	92	7	18
C	28481	23	2					138-	96	9	17
C	28482	23	13					138-	96	13	18
C	28483	23	19					138-	96	19	13
C	28645	33	19					138-	96	25	13
C	28805	33	29					138-	99	35	15
C	28817	33	22					138-	320	15	17
C	28971	5	5					138-	2040	33	6
								138-	2073	9	4

HARDWARE CODE NUMBERS

12-	632	13	7
83-	44	33	31
111-	108	33	23
111-	202	15	14
111-	202	29	19
111-	202	33	23
111-	207	15	20
111-	132	19	8
111-	132	25	8
111-	202	31	19
111-	203	7	15
111-	203	9	14
111-	203	13	15
111-	203	35	3
111-	302	29	9
111-	330	7	7
111-	340	29	15
111-	340	31	15
111-	371	29	10
111-	371	31	10
113-	1	29	12
113-	1	31	12
113-	102	33	37
113-	102	37	4
113-	103	37	12
113-	206	17	8
113-	206	23	8
113-	206	29	5
113-	207	5	11
113-	207	9	20
113-	207	11	11
113-	207	11	13
113-	207	15	22
113-	207	17	16
113-	207	21	20
113-	207	27	20
113-	207	31	5
113-	207	37	3
113-	219	33	16
113-	233	17	16
113-	233	23	16
113-	410	19	20
113-	410	25	20
113-	417	35	10
126-	16	33	33

NUMERICAL INDEX

PART NO.	PAGE NO.	REF. NO.	PART NO.	PAGE NO.	REF. NO.	PART NO.	PAGE NO.	REF. NO.
138-	2073	15	4	195-	545	29	4	
138-	2073	21	5	195-	549	33	2	
138-	2073	27	5	195-	2037	5	9	
138-	2073	33	6	195-	2037	11	9	
138-	2073	33	13	195-	2037	17	14	
141-	4	15	26	195-	2037	23	14	
141-	4	21	14	321-	4199	39	1	
141-	4	27	14	321-	4381	39	11	
141-	56	33	19	321-	4446	37	16	
151-	88	37	9	321-	4447	39	15	
178-	858	33	35	321-	4686	39	13	
192-	6	5	10	321-	4750	39	15	
192-	19	33	25	321-	4753	39	2	
192-	20	7	17	321-	4757	39	1	
192-	20	9	16	321-	4761	39	16	
192-	20	13	17	321-	4763	39	11	
192-	20	15	16	321-	6379	39	4	
192-	20	19	9	321-	6380	39	9	
192-	20	25	9	321-	6433	39	10	
192-	20	29	21					
192-	20	31	21					
192-	20	33	25					
192-	20	35	4					
192-	21	7	9					
192-	21	11	10					
192-	21	11	14					
192-	21	13	9					
192-	21	17	9					
192-	21	17	15					
192-	21	23	9					
192-	21	23	15					
192-	21	29	7					
192-	21	31	7					
192-	21	33	8					
195-	103	7	8					
195-	103	19	17					
195-	103	25	17					
195-	106	9	11					
195-	106	15	11					
195-	521	37	13					
195-	521	37	19					
195-	522	29	39					
195-	522	31	3					
195-	525	7	26					
195-	525	9	10					
195-	525	13	20					
195-	525	15	10					
195-	525	21	16					
195-	525	27	16					
195-	525	29	25					
195-	525	31	25					
195-	529	9	8					
195-	533	7	4					
195-	533	19	4					
195-	533	21	12					
195-	533	25	4					
195-	533	27	12					
195-	529	15	8					
195-	533	13	4					

INGERSOLL
Ingersoll Equipment Co., Inc.

L47 ROTARY MOWER
FOR COMPACT TRACTORS
Parts Catalog 8-2710

2-84-RP-1500

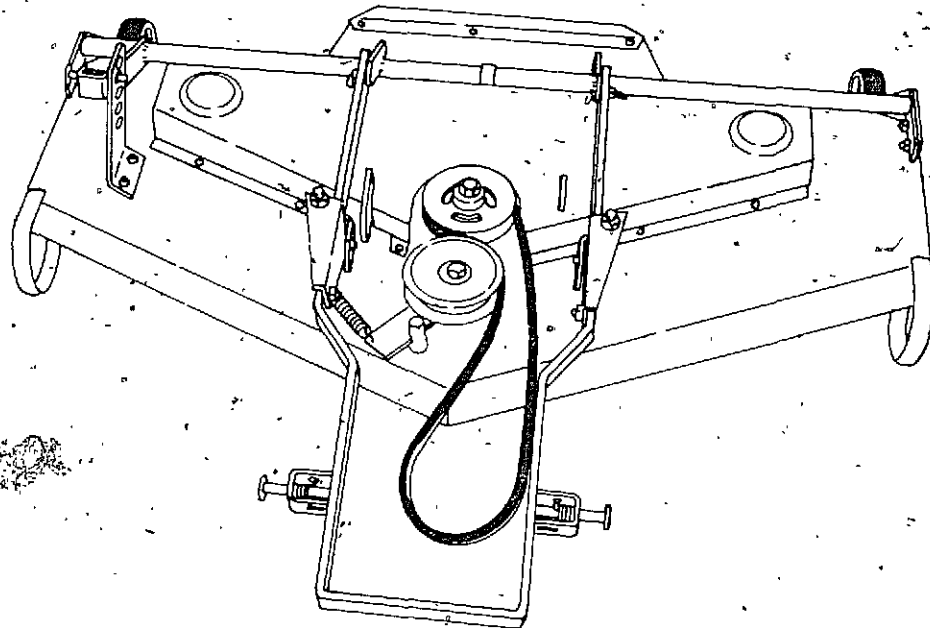

ALPHABETICAL INDEX

	PAGE	GRID
Axle	9	F8
Bearings, Spindles	7	F6
Belts	5	F4
Blades	7	F6
Decals	9	F8
Deck	5	F4
Frame, Mounting	9	F8
Guards and Covers	5	F4
Housing, Spindles	7	F6
Lift Links	5	F4
Pulleys	7	F6
Spindles	7	F6
Wheels	9	F8

NOTE: See grid A2 for -
G41, H41 Rotary Mowers,
G51 Snow Blade,
G81 Snow Caster

NOTE: See grid C2 for -
J41, K41, L41, M41, N41, P41 Rotary
Mowers,
J81, K81, L81, M81, N81, P81,
R81 Snow Casters
G51, H51, J51 Blade
B96 Bagger

ATTACHMENT APPLICATION CHART

MOWER	TRACTOR
L47	110 - PIN 14032840 and after 116 - All

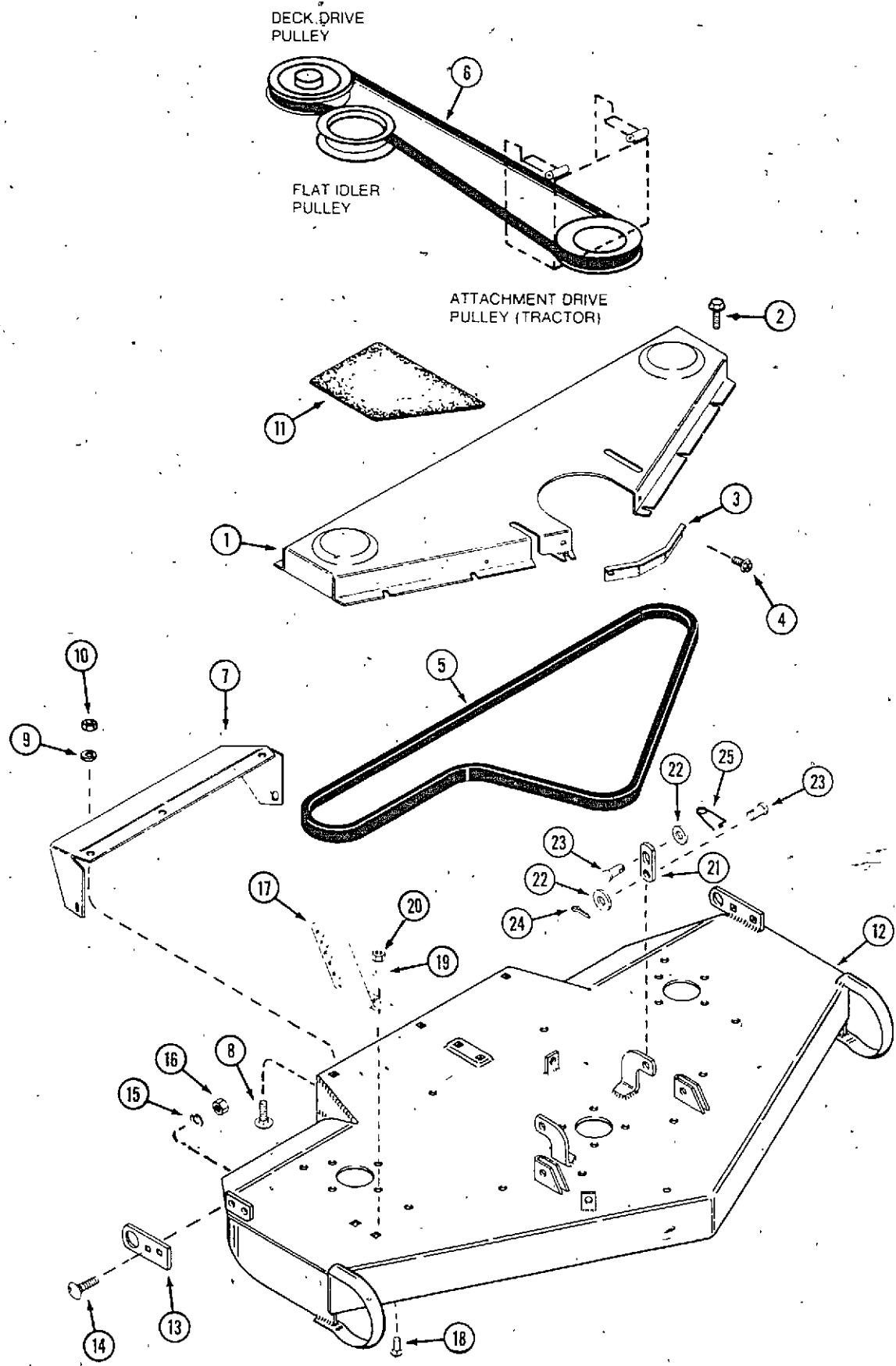

DECK, BELTS AND COVERS

REF.	PART NO.	DESCRIPTION	REQ'D
1	C 27091	COVER - deck belt	1
2	187- 1036	SCREW - 1/4" - 20 x 1/2" self tapping	10
3	C 27092	GUARD - deck belt	1
4	187- 1328	SCREW - No. 8 - 18 x 3/8" self tapping	2
5	C 22707	BELT - deck	1
6	C 27120	BELT - drive	1
7	C 27093	DEFLECTOR	1
8	111- 101	BOLT - 1/4" - 20 x 5/8" carriage	5
9	192- 19	LOCK WASHER - 1/4"	5
10	129- 101	NUT - 1/4"	5
11	C 27094	PAD - footrest R.H. (shown)	1
11	C 27095	PAD - footrest L.H.	1
12	C 27098	DECK - mower	1
13	C 15560	BRACKET - axle pivot	1
14	111- 371	BOLT - 3/8" - 16 x 1" carriage	2
15	192- 21	LOCK WASHER - 3/8"	2
16	129- 103	NUT - 3/8"	2
17	C 25408	BRACKET - height adjust	1
18	111- 132	BOLT - 5/16" - 18 x 3/4" carriage	2
19	193- 29	LOCK WASHER - 5/16"	2
20	129- 102	NUT - 5/16"	2
21	C 27096	LINK - lift	2
22	195- 533	WASHER - 1/2"	4
23	C 10821	PIN - clevis	4
24	132- 310	PIN - cotter 1/8" x 1"	2
25	C 10898	PIN - safety	2

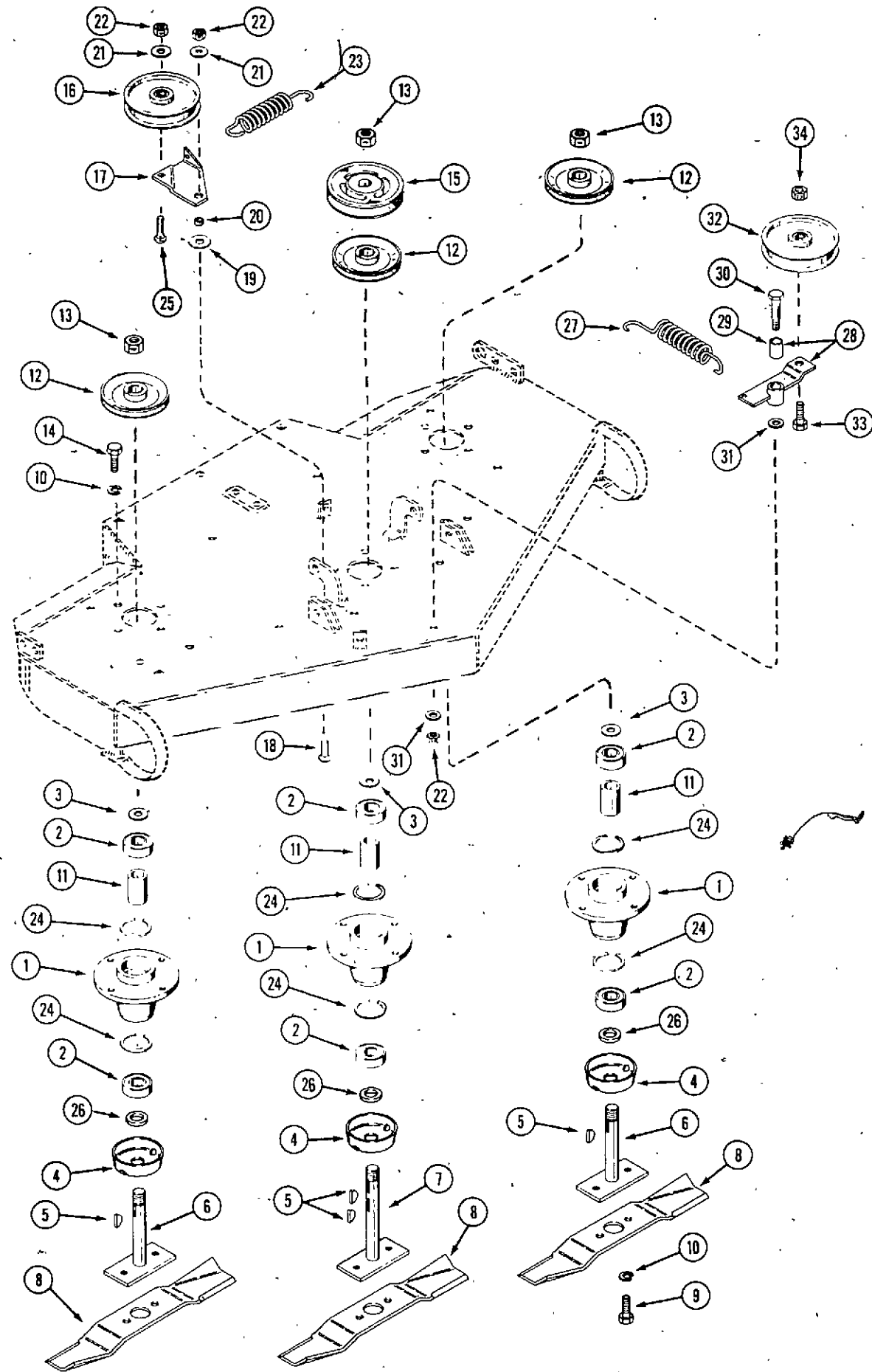

PULLEYS, BLADES AND SPINDLES

REF.	PART NO.	DESCRIPTION	REQ'D
1	C 17666	HOUSING - mower spindle (also requires (2) C16516 retainers)	3
2	A 70280	BEARING - spindle	6
3	A 70282	WASHER - bearing seal	3
4	C 25543	SHIELD - bearing	3
5	126- 19	KEY - spindle, #11 Woodruff	4
6	C 15763	SPINDLE - outboard	2
7	C 15604	SPINDLE - center	1
8	C 27113	BLADE - 15-1/2"	3
9	113- 205	BOLT - 3/8" x 5/8" NC hex (grade 5)	6
10	192- 21	LOCK WASHER - 3/8"	18
11	C 10810	SPACER - bearing	3
12	C 21581	PULLEY - spindle	3
13	131- 1331	NUT - jam lock 3/4" NF hex	3
14	113- 206	BOLT - 3/8" x 3/4" NC hex	12
15	C 15615	PULLEY - drive	1
16	C 12251	PULLEY - deck idler	1
17	C 27108	BRACKET - idler	1
18	111- 371	BOLT - 3/8" x 1" carriage, short neck	1
19	195- 105	WASHER - 1/2" ZP	1
20	C 14768	SPACER - idler bracket	1
21	195- 525	WASHER - 3/8" ZP	2
22	131- 1181	NUT - lock 3/8" NC hex	3
23	C 14482	SPRING - idler, deck belt	1
24	C 16516	RING - retainer	6
25	111- 366	BOLT 3/8" x 1-1/4" carriage, short neck	1
26	C 25541	SPACER - spindle	3
27	C 24321	SPRING - idler, drive belt	1
28	C 27109	IDLER ARM ASSEMBLY	1
29	C 16714	BUSHING - sleeve	1
30	C 16745	BOLT - shoulder	1
31	195- 103	WASHER - 3/8"	2
32	C 26090	PULLEY - idler, drive belt	1
33	113- 410	BOLT - 1/2" - 13 x 1-1/2"	1
34	131- 1308	NUT - 1/2" - 13 lock	1

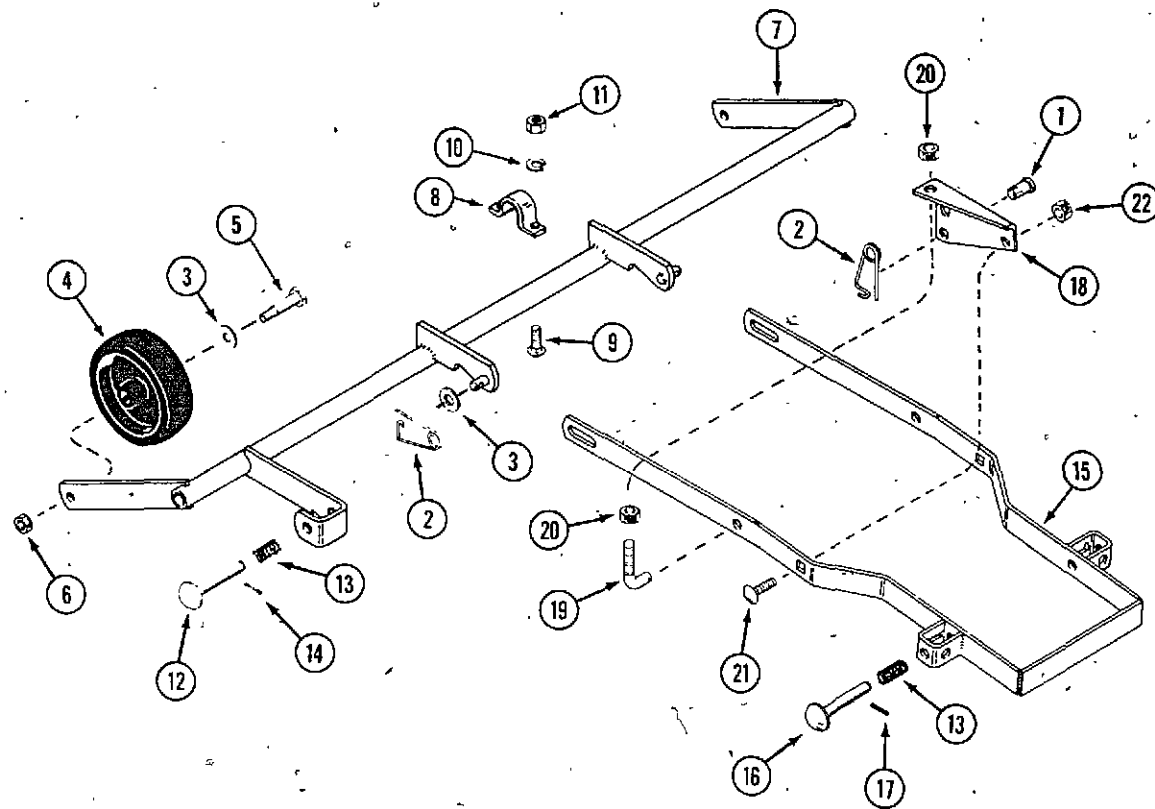

REF.	PART NO.	DESCRIPTION	REQ'D
1	C 10821	PIN - clevis	2
2	C 10898	PIN - safety	4
3	195- 533	WASHER - 1/2"	4
4	C 26736	WHEEL - gauge	2
5	C 16745	BOLT - shoulder	2
6	131- 1181	NUT - 3/8" - 16 lock	2
7	C 27106	AXLE - rear	1
8	C 14932	BRACKET - axle mounting	1
9	111- 101	BOLT - 1/4" 20 x 3/4" carriage	2
10	192- 19	LOCK WASHER - 1/4"	2
11	129- 101	NUT - 1/4" - 20	2
12	C 20005	PIN - retaining	1
13	C 10482	SPRING	2
14	138- 96	PIN - roll 3/16" x 1"	1
15	C 27115	FRAME - mounting	1
16	C 15278	PIN - retaining	2
17	138- 99	PIN - roll 3/16" x 1-3/8"	2
18	C 27118	BRACKET - suspension adjust R.H. (shown)	1
18	C 27119	BRACKET - suspension adjust L.H.	1
19	C 19088	BOLT - "J", suspension adjust	2
20	131- 1182	NUT - 1/2" - 13 lock	4
21	111- 517	BOLT - 1/2" - 13 x 1" carriage	2
22	131 1308	NUT - 1/2" - 13 lock	2

DECALS

1	C 26090	DECAL - drive belt (ENGLISH) shown	1
2	C 12519	DECAL - "No Step" (ENGLISH) shown	1
2	321- 4726	DECAL - "No Step" (FRENCH)	1
3	321- 6210	DECAL - cutting height (ENGLISH) shown	1
3	321- 4698	DECAL - cutting height (FRENCH)	1
4	321- 4381	DECAL - "Spinning Blade" (ENGLISH) shown	1
4	321- 4763	DECAL - "Spinning Blade" (FRENCH)	1
5	321- 4974	DECAL - "Flying Debris" (ENGLISH) shown	1
5	321- 6642	DECAL - "Flying Debris" (FRENCH)	1

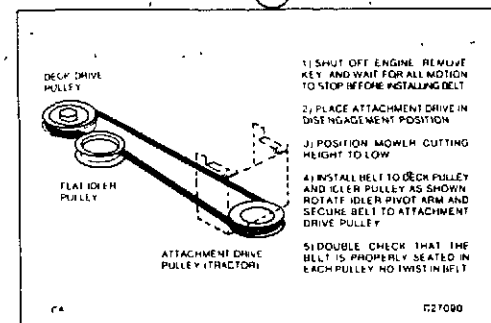
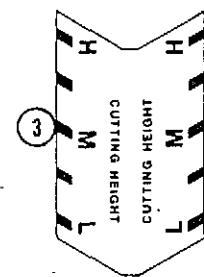
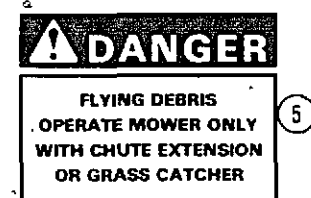

NUMERICAL INDEX

PART NO.	PAGE NO.	REF. NO.	PART NO.	PAGE NO.	REF. NO.	PART NO.	PAGE NO.	REF. NO.
A	70280	7	2	111-	371	7	18	
A	70282	7	3	111-	517	9	21	
C	10482	9	13	113-	205	7	9	
C	10810	7	11	113-	206	7	14	
C	10821	5	23	113-	410	7	33	
C	10821	9	1	126-	19	7	5	
C	10898	5	25	129-	101	5	10	
C	10898	9	2	129-	101	9	11	
C	12251	7	16	129-	102	5	20	
C	12519	9	2	129-	103	5	16	
C	14482	7	23	131-	1181	7	22	
C	14768	7	20	131-	1181	9	6	
C	14932	9	8	131-	1182	9	20	
C	15278	9	16	131-	1308	7	34	
C	15560	5	13	131-	1308	9	22	
C	15604	7	7	131-	1331	7	13	
C	15615	7	15	132-	310	5	24	
C	15763	7	6	138-	96	9	14	
C	16516	7	24	138-	99	9	17	
C	16714	7	29	187-	1036	5	2	
C	16745	7	30	187-	1328	5	4	
C	16745	9	5	192-	19	5	9	
C	17666	7	1	192-	19	9	10	
C	19088	9	19	192-	21	5	15	
C	20005	9	12	192-	21	7	10	
C	21581	7	12	193-	29	5	19	
C	22707	5	5	195-	103	7	31	
C	24321	7	27	195-	105	7	19	
C	25408	5	17	195-	525	7	21	
C	25541	7	26	195-	533	5	22	
C	25543	7	4	195-	533	9	3	
C	26090	7	32	321-	4381	9	4	
C	26090	9	1	321-	4698	9	3	
C	26736	9	4	321-	4726	9	2	
C	27091	5	1	321-	4763	9	4	
C	27092	5	3	321-	4974	9	5	
C	27093	5	7	321-	6210	9	3	
C	27094	5	11	321-	6642	9	5	
C	27095	5	11					
C	27096	5	21					
C	27098	5	12					
C	27106	9	7					
C	27108	7	17					
C	27109	7	28					
C	27113	7	8					
C	27115	9	15					
C	27118	9	18					
C	27119	9	18					
C	27120	5	6					

HARDWARE CODE NUMBERS

111-	101	5	8
111-	101	9	9
111-	132	5	18
111-	366	7	25
111-	371	5	14

INGERSOLL
Ingersoll Equipment Co., Inc.