

CASE MODEL 210  
 COMPACT TRACTOR  
 S/N 9733525 AND AFTER  
 Parts Catalog A1374

NOTE: This catalog replaces  
 catalog No. 1374 and  
 all of its revisions.

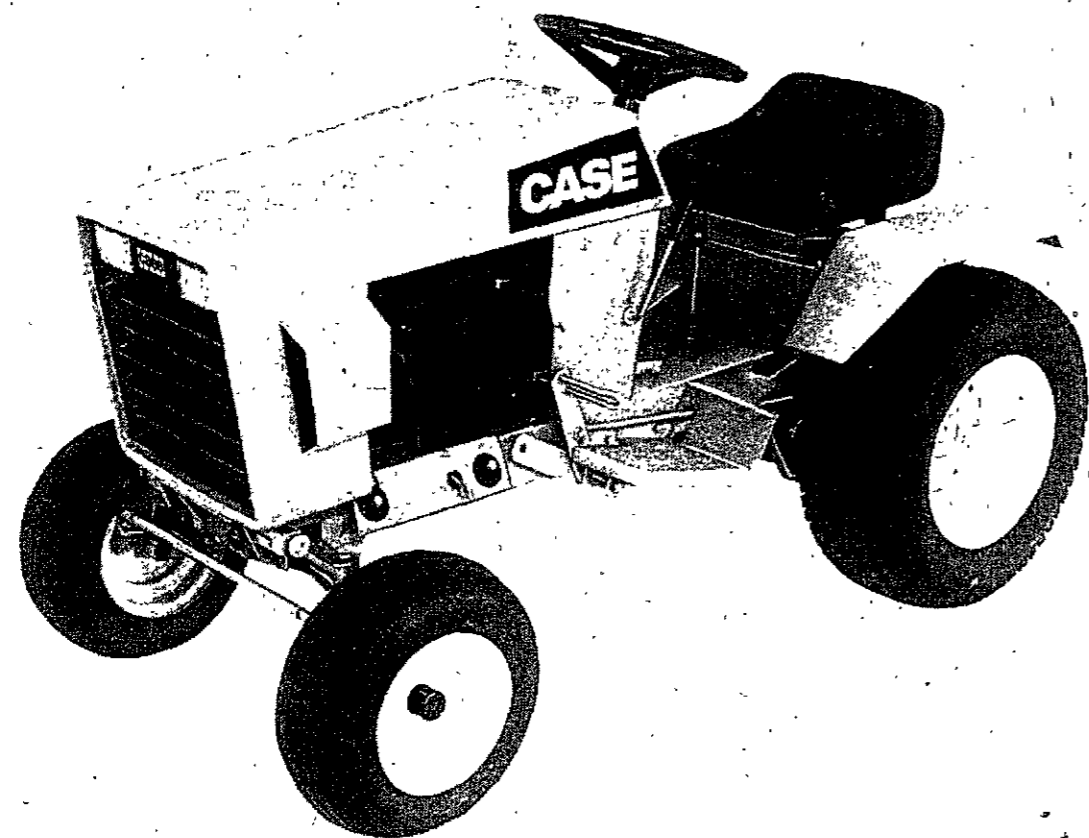

ALPHABETICAL INDEX

ENGINE SECTION

	PAGE	GRID		PAGE	GRID
Air Cleaner	5	A6	Fuel Pump	15	B2
Battery	49	D8	Fuel Strainer	15	B2
Breather, Crankcase	7	A8	Fuel System	15	B2
Camshaft	7	A8	Gasket Kits	13	A14
Carburetor	15-17	B2-B4	Governor	19	B6
Connecting Rod	9	A10	Muffler	5	A6
Crankshaft	9	A10	Oil Pan	11	A12
Cylinder Block	11	A12	Piston	9	A10
Cylinder Head	11	A12	PTO Clutch	23	B10
Electrical System	47-51	D6-D10	Spark Plug	49	D8
Engine Block & Attaching Parts	11	A12	Starter	47	D6
Engine Mounts	19	B6	Stator	11	A12
Exhaust System	5	A6	Tank, Fuel	15	B2
Filter, Breather	7	A8	Throttle Linkage	19	B6
Flywheel	11	A12	Valves	7	A8

BASIC TRACTOR SECTION

	PAGE	GRID		PAGE	GRID
Axle, Front	29	C2	Model K8 Wheel Weights	55	D14
Axle, Rear	41-43	C14-D2	Model J21 Sleeve Hitch	57	E2
Baffles & Shrouds	15	B2	Model H13 Weight Box	59	E4
Brakes	39	C12	Model K18 Counterweight		
Decals	53	D12	Brackets	59	E4
Electrical System	47-51	D6-D10	Pulleys, Belts and Idlers	33-37	C6-C10
Fenders	27	B14	P.T.O. Clutch	21-23	B8-B10
Frame	25	B12	Seat, Operator's	27	B14
Grille	25	B12	Shields, Muffler	21	B8
Hitch	45	D4	Steering Wheel & Gear	31	C4
Hood	25	B12	Tail Lamp	55	D14
Implement Lift Lever	45	D4	Tool Box	27	B14
L11 Counterweight Brackets	61	E6	Transmission	41-43	C14-D2
L29 PTO	63	E8	Wheels, Front & Rear	29	C2

J I Case  
 A Tenneco Company



OPE Division  
 Technical Publications  
 119 S. First Street  
 Winneconne, Wis. 54986

**GENERAL INFORMATION**

CASE MODEL 210 COMPACT TRACTOR

**INDEX**

There is an index at the front and rear of this catalog.

The front index is an alphabetical index of the major groups or assemblies.

The rear index is a numerical index of the part numbers and pages on which these numbers are shown.

**ILLUSTRATION**

Each illustration in this catalog shows a group of parts or components. These parts and components are aligned approximately as the parts and components on your machine. Each part and component in an illustration has a reference number. These reference numbers are in a list on the page opposite of the illustration. Next to the reference number is the part number, description and required quantity of the part shown in the illustration.

**ABBREVIATIONS**

UAR - "Use as required" indicates that the part quantity is variable.

NSS - "Not sold separately" indicates that the part is only available as a component of an assembly or the part must be purchased locally. If the part is an assembly component, the description will be indented under the assembly description in the parts list.

**INDENTED DESCRIPTIONS**

An assembly can have many components. The components of an assembly are indicated by an indented description. The quantity for an indented part is the total needed for that complete assembly. See the example.

**PARTS ORDERS**

All orders must include the following information:

1. Correct part number.
2. Complete description of part or component.
3. Total quantity of each part or component.
4. Product model number.
5. All necessary product identification numbers.
6. Method for sending the parts.
7. Complete and correct address.

**CATALOG REVISIONS**

As the product changes, we will send you new pages for your catalog.

**IMPORTANT:** Put all revisions into the catalog as soon as possible.

**RIGHT HAND AND LEFT HAND IDENTIFICATION**

The words right hand (RH) and left hand (LH) as used in this catalog indicate the direction while you are in the operator's seat in the normal operating position.

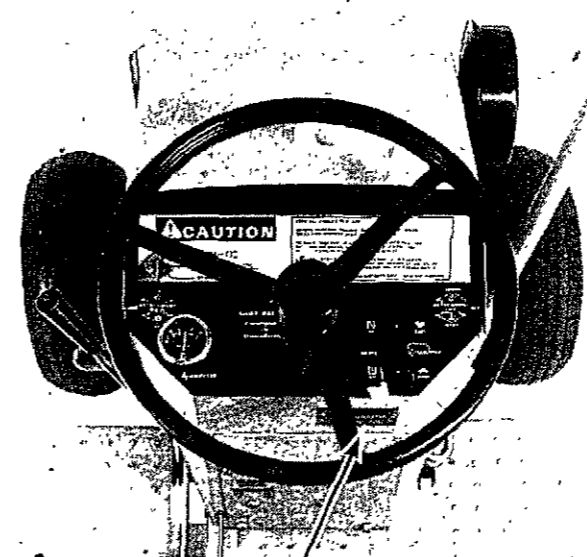

TRACTOR MODEL AND SERIAL NUMBER

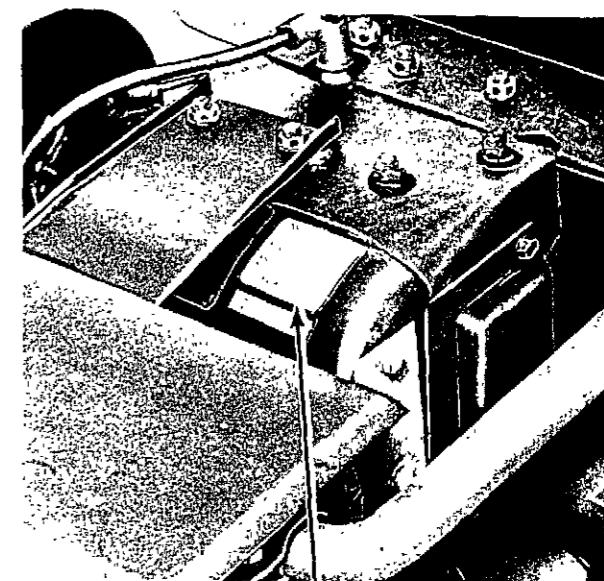

ENGINE MODEL, SERIAL AND SPECIFICATION NUMBER

TRACTOR MODEL DESIGNATION	ENGINE MODEL DESIGNATION
210 TRACTOR	K-241-A5 C24784 SPEC. PF-46746D

REF.	PART NO.	DESCRIPTION	REQ'D
	A 55159	CYLINDER ASSY - rear steering	1
28	A 56208	SOCKET ASSY - rear cylinder	1
29	A 55956	PLUG - adjusting, socket assy	1
30	A 55957	SEAT - socket ball	2
31	A 56210	SPRING - socket	1
32	A 56209	SEAT - socket spring	1
33	G 45175	CLAMP ASSY - socket assy	1
	16- 836	BOLT - 1/2" x 2-1/4" N.F. hex.	1
34	132- 104	PIN - cotter, 3/16" x 3"	1
35	A 55889	STUD - ball, socket & cylinder	2
36	13- 410	BOLT - 1/4" x 5/8" N.C., hex.	4
37	92- 4	LOCKWASHER - 1/4" SAE	4

**SERIAL NUMBERS**

When using this catalog, notice the reference to serial numbers of various components noted here and listed in the "description" copy. By referring to correct serial numbers, proper parts identification will be assured.

**AIR CLEANER**

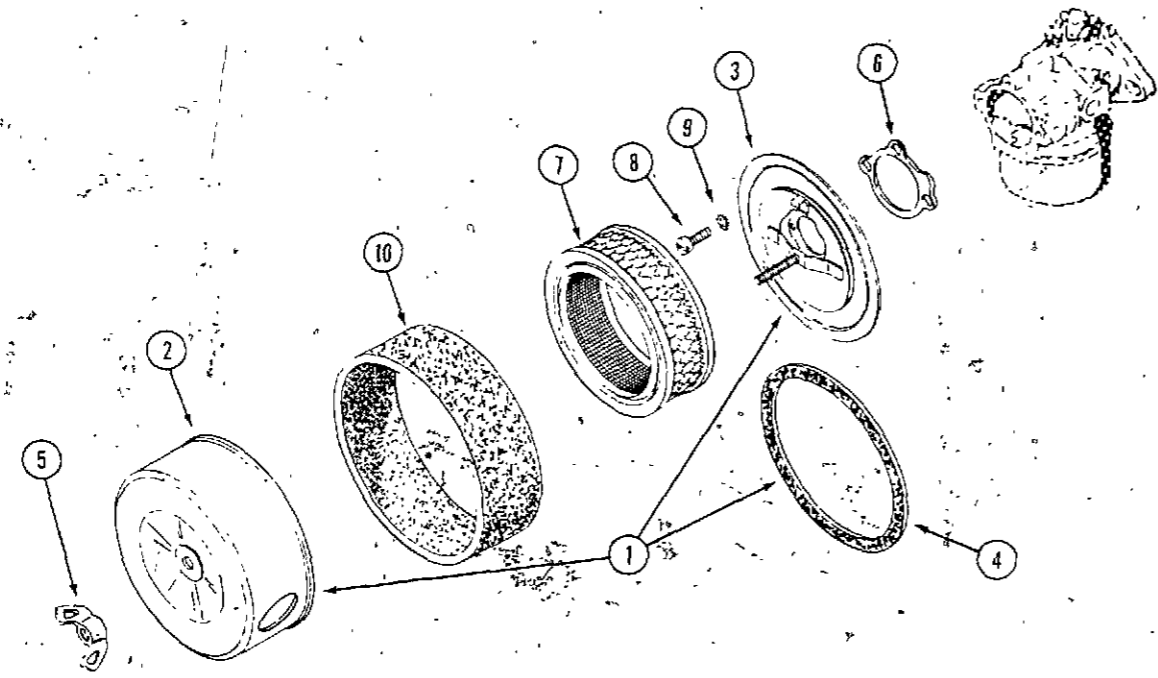

REF.	PART NO.	DESCRIPTION	REQ'D
1	KO 237895	AIR CLEANER ASSEMBLY	1
2	NSS	COVER - air cleaner (order KO237895)	1
3	NSS	BASE - air cleaner (order KO237895)	1
4	KO 237423	GASKET - cover, air cleaner	1
5	C 26703	NUT - wing 1/4" N.C.	1
6	KO 275341	GASKET - air horn	1
7	A 70090	ELEMENT - air cleaner	1
8	177- 94	SCREW - fillister head 10-32 x 5/16"	3
9	193- 6	LOCKWASHER - ext. tooth	3
10	KO 237421	PRE-CLEANER	1

**EXHAUST SYSTEM**

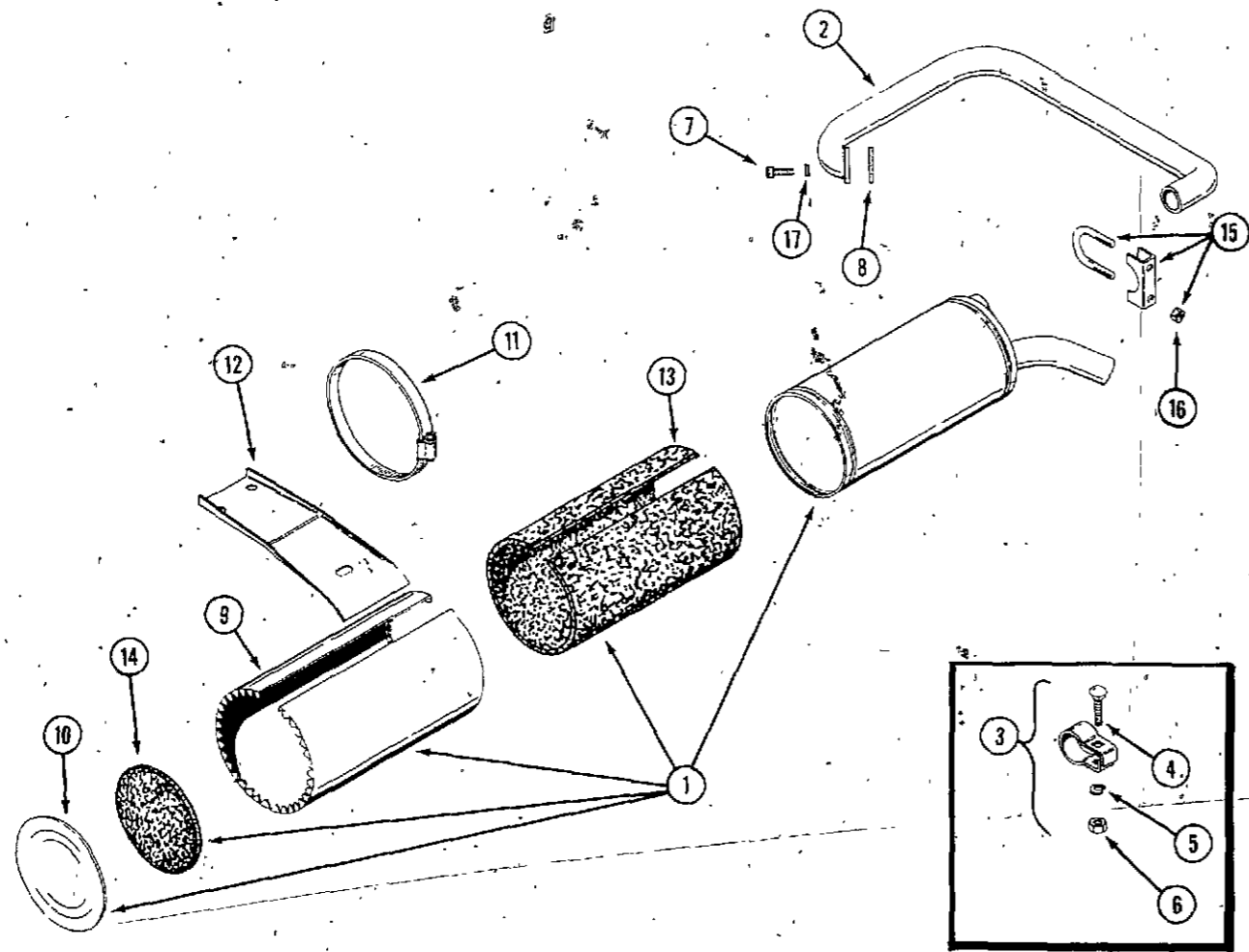

1	C 26063	MUFFLER ASSEMBLY - exhaust (includes items 9, 10, 13 and 14 banded together)	1
2	C 22747	PIPE - engine exhaust	1
3	NSS	CLAMP ASSEMBLY - muffler (use H315176)	1
4	111- 256	BOLT - 5/16" x 1-1/4" round head N.C.	1
5	192- 20	LOCKWASHER - 5/16"	1
6	129- 102	NUT - 5/16" N.C. hex.	1
7	61- 512	BOLT - 5/16" x 5/8" socket head	2
8	C 10372	GASKET - exhaust	1
9	C 26062	WRAPPER - muffler	1
10	C 22889	COVER - muffler end	1
11	214- 272	CLAMP - muffler and wrapper mounting	3
12	C 22819	BRACKET - muffler mounting	1
13	C 26058	INSULATION - muffler	1
14	C 22860	INSULATION - muffler end	1
15	H 315176	CLAMP - muffler	1
16	129- 102	NUT - muffler clamp	2
17	192- 404	LOCKWASHER - 5/16"	2

CRANKCASE BREATHER

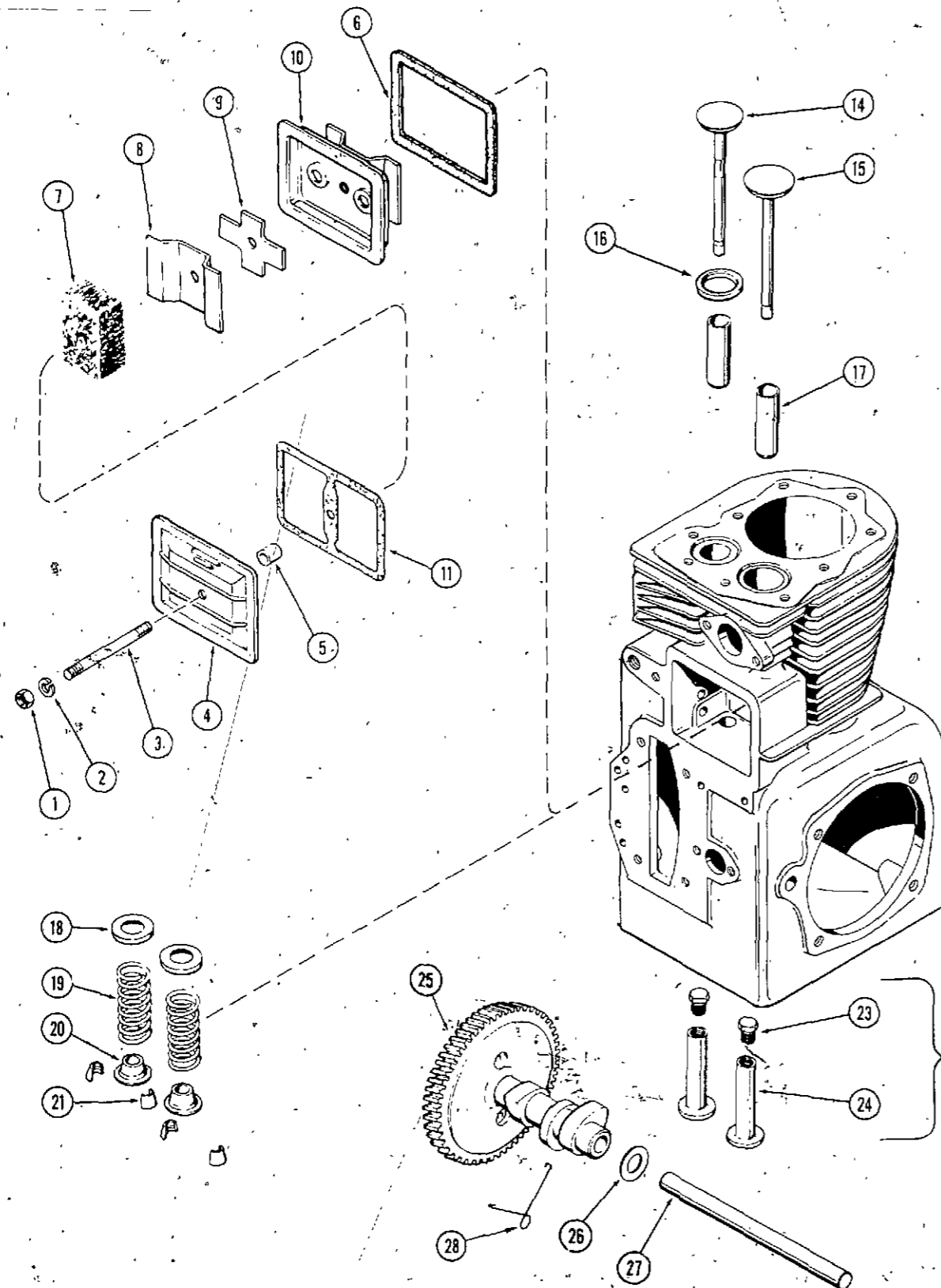

REF	PART NO.	DESCRIPTION	REQ'D
1	129- 409	NUT - 1/4" NC hex	1
2	92- 4	LOCKWASHER - 1/4"	1
3	KO 275220	STUD - valve cover	1
4	KO 275143	COVER - valve	1
5	KO 231032	SEAL - breather	1
6	KO 235048	GASKET - breather plate	1
7	KO 235118	FILTER - breather	1
8	KO 235117	BAFFLE - breather	1
9	KO 235047	REED - breather	1
10	KO 235631	PLATE - breather	1
11	KO 275144	GASKET - valve cover	1

CAMSHAFT AND VALVES

14	KO 235826	VALVE - exhaust	1
15	KO 235008	VALVE - intake	1
16	KO 230170	INSERT - exhaust valve seat	1
17	KO 235007-S	GUIDE - valve	2
18	KO 235011	SEAT - valve spring	2
19	KO 235010	SPRING - valve	2
20	KO 230011	RETAINER - valve spring	2
21	C 24884	KIT - valve retainer lock (includes both halves)	2
22	KOD 235327	LIFTER ASSEMBLY	2
23	NSS	SCREW - tappet adjusting	1
24	NSS	LIFTER - valve	1
25	C 25043	CAMSHAFT ASSEMBLY	1
26	KO 275066	SPACER - camshaft, .005"	UAR
26	KO 275067	SPACER - camshaft, .010"	UAR
27	KO 235053	PIN - camshaft	1
28	V 34346	SPRING - actuating	1

CRANKSHAFT, PISTON AND CONNECTING ROD

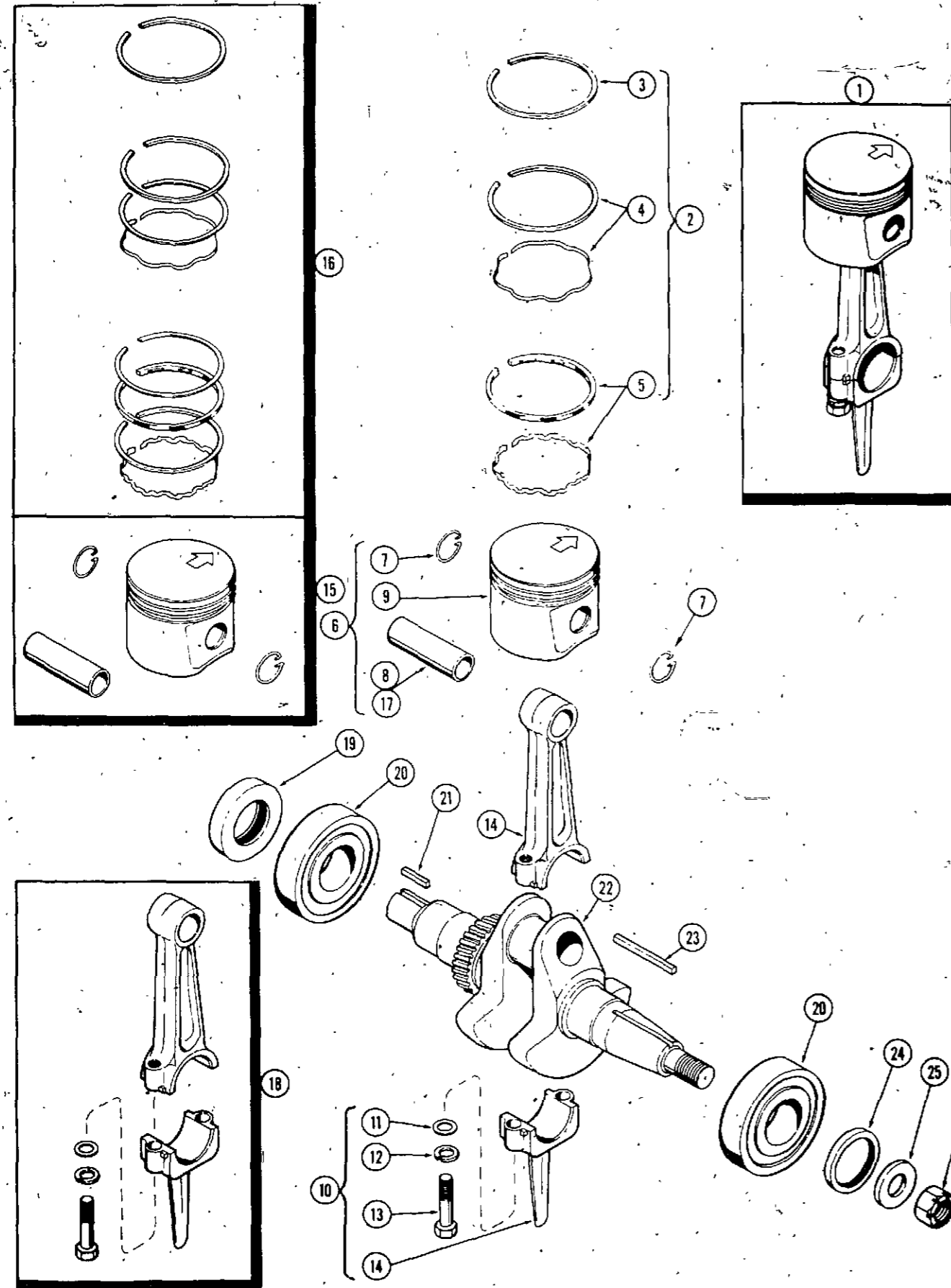

REF.	PART NO.	DESCRIPTION	REQ'D
1	NSS	PISTON AND ROD ASSEMBLY (Std. size)	1
2	KO 235287	RING SET - piston (For oversize, see item 16)	1
3	NSS	RING - top compression	1
4	NSS	RING - 2nd compression (Includes expander)	1
5	NSS	RING - oil (Includes expander)	1
6	C 26509	PISTON ASSEMBLY (For oversize, see item 15)	1
7	KO 235004	RETAINER - piston pin	2
8	NSS	PIN - piston	1
9	NSS	PISTON	1
10	KOA 235139	CONNECTING ROD AND ASSEMBLY (For undersize, see item 18)	1
11	KO 235003	WASHER - special	2
12	92- 6	LOCKWASHER	2
13	NSS	SCREW - cap, connecting rod	2
14	NSS	ROD - connecting	1
15	C 26510	PISTON ASSEMBLY - .003 oversize (use-std. ring set)	1
15	C 26511	PISTON ASSEMBLY - .010" oversize	1
15	C 26512	PISTON ASSEMBLY - .020" oversize	1
15	C 26513	PISTON ASSEMBLY - .030" oversize	1
16	KO 235288	RING SET - piston .010" oversize	1
16	KO 235289	RING SET - piston .020" oversize	1
16	KO 235290	RING SET - piston .030" oversize	1
17	NSS	PIN - piston, .005" oversize	1
18	C 18101	CONNECTING ROD ASSEMBLY - .010" undersize	1
19	R 16287	OIL SEAL - crankshaft rear	1
20	40035	BEARING - crankshaft, ball	2
21	H 26492	KEY - 1/4" Sq. x 3/4" (Pump Coupling)	1
22	KOB 236364	CRANKSHAFT	1
23	H 233346	KEY - flat 3/16" x 3/16" x 3/4" (Flywheel)	1
24	C 18097	OIL SEAL - crankshaft front	1
25	C 26421	WASHER - 5/8"	1
26	131- 580	NUT - special Marsden 5/8" NF.	1

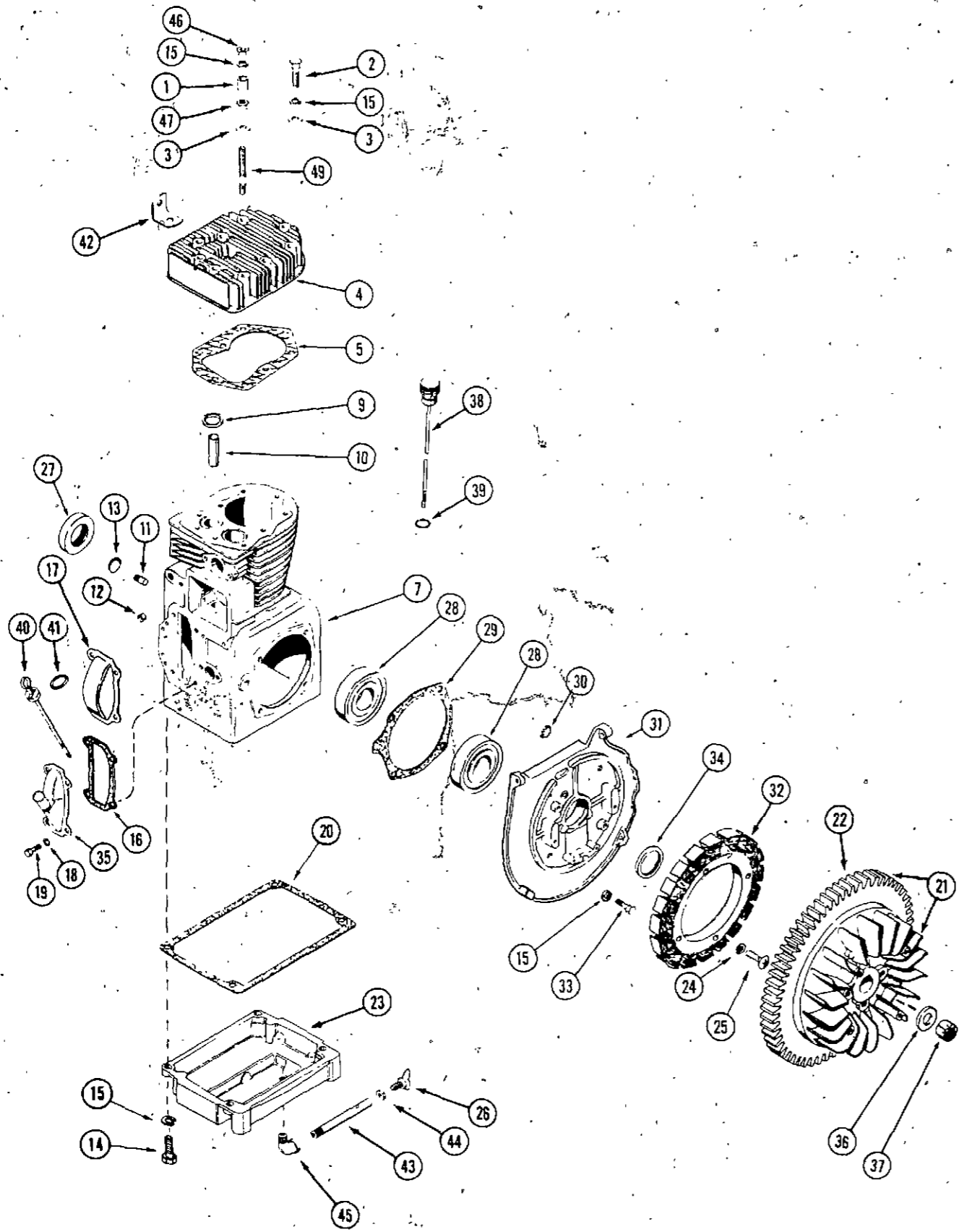

ENGINE BLOCK AND ATTACHING PARTS

NOTE: To order complete engine see page 1.

REF.	PART NO.	DESCRIPTION	REQ'D
1	C 21814	SPACER - cylinder head	6
2	KO 270158	BOLT - cylinder head	2
3	KO 270889	WASHER - cylinder head	9
4	KO 236675	HEAD - cylinder	1
5	KO 237658	GASKET - head	1
7	C 27283	BLOCK ASSEMBLY - cylinder, short (Includes crankshaft, piston assembly, ring set, crankshaft seals, rod assembly, camshaft assembly, valves, bearings, plate and plate gasket, governor gear assembly and cross shaft) (also includes gaskets)	1
9	KO 230170	INSERT - exhaust valve	1
10	KO 235007-S	GUIDE - valve	2
11	KO 235125-S	SHAFT - stub, governor	1
12	V 34418	BEARING - needle, governor shaft	1
13	41- 18	PLUG - expansion	1
14	113- 209	BOLT - 3/8" x 1-1/2" NC hex plated	4
15	192- 21	LOCKWASHER - 3/8" plated	17
16	KO 235025	GASKET - camshaft cover	1
17	KO 235026	COVER - camshaft gear	1
18	192- 19	LOCKWASHER - 1/4" plated	4
19	13- 48	BOLT - 1/4" x 1/2" NC plated	4
20	KO 235353	GASKET - oil pan	1
21	C 27279	FLYWHEEL ASSEMBLY	1
22	NSS	RING GEAR	1
23	C 22699	BASE - oil pan	1
24	193- 99	LOCKWASHER - internal tooth	4
25	182- 541	SCREW - stator	4
26	C 14399	PLUG - oil drain	1
27	R 16287	OIL SEAL - crankshaft rear	1
28	40035	BEARING - crankshaft ball	2
29	KO 235757	GASKET - bearing plate	1
29	KO 235070	GASKET - shim, .010	1
30	205- 27	PLUG - button, timing hole	1
31	C 24290	PLATE - bearing	1
32	V 34427	STATOR - 15 amp	1
33	C 25338	CONNECTOR - stator	1
33	113- 207	BOLT - 3/8" x 1" NC plated	4
34	C 18097	OIL SEAL - crankshaft front	1
35	C 24490	COVER - camshaft	1
36	C 26421	WASHER - special, plated	1
37	131- 580	NUT - special, Marsden	1
38	C 14953	DIPSTICK ASSEMBLY	1
39	A 27365	"O" RING - dipstick	1
40	C 24491	DIPSTICK - oil	1
41	A 42597	"O" RING - dipstick	1
42	KO 235748	STRAP - lifting	1
43	C 18814	NIPPLE - oil drain extension	1
44	C 14906	GASKET - plug, oil drain	1
45	221- 1412	ELBOW - street	1
46	129- 143	NUT - 3/8" NC hex, jam	6
47	129- 103	NUT - 3/8" NC hex	6
49	KO 237277	STUD - cylinder head	7

ENGINE GASKET AND SEAL KIT

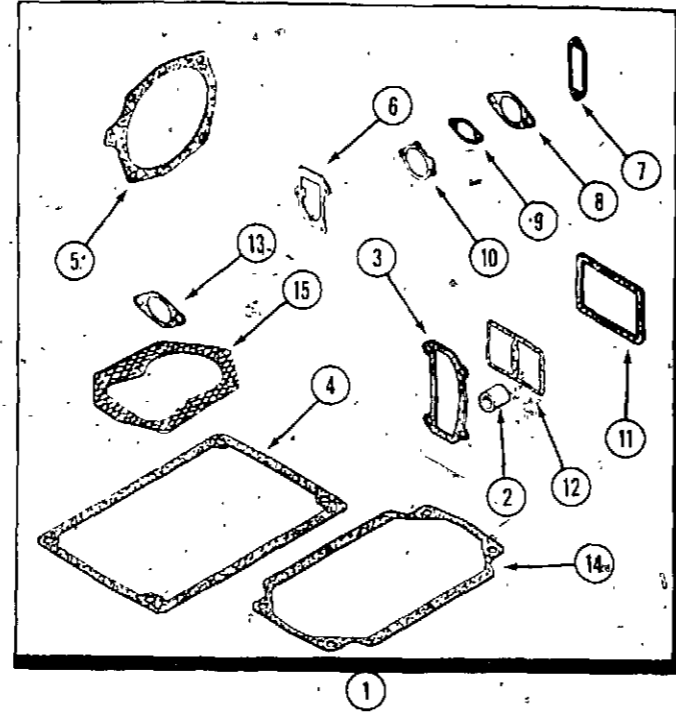

REF	PART NO	DESCRIPTION	REQ'D
1	C 23858	KIT - engine gasket (10 thru 14 hp engines)	1
2	KO 231032	SEAL - breather (14 hp engine)	1
3	KO 235025	GASKET - camshaft cover	1
4	KO 235353	GASKET - oil pan	1
5	KO 235757	GASKET - bearing plate	6
5	KO 235070	GASKET - shim (.010")	UAR
6	KO 237064	GASKET - oil fill tube (used on 14 hp)	1
7	KO 220174	GASKET - breaker cover	1
8	C 23860	GASKET - carburetor flange	1
9	C 24887	GASKET - fuel pump flange	1
10	KO 275341	GASKET - carburetor air horn	1
11	KO 235048	GASKET - breather plate	1
12	KO 275144	GASKET - valve cover	1
13	C 10372	GASKET - exhaust	1
14	KO 235057	GASKET - pan (not used)	1
15	KO 237658	GASKET - cylinder head	1

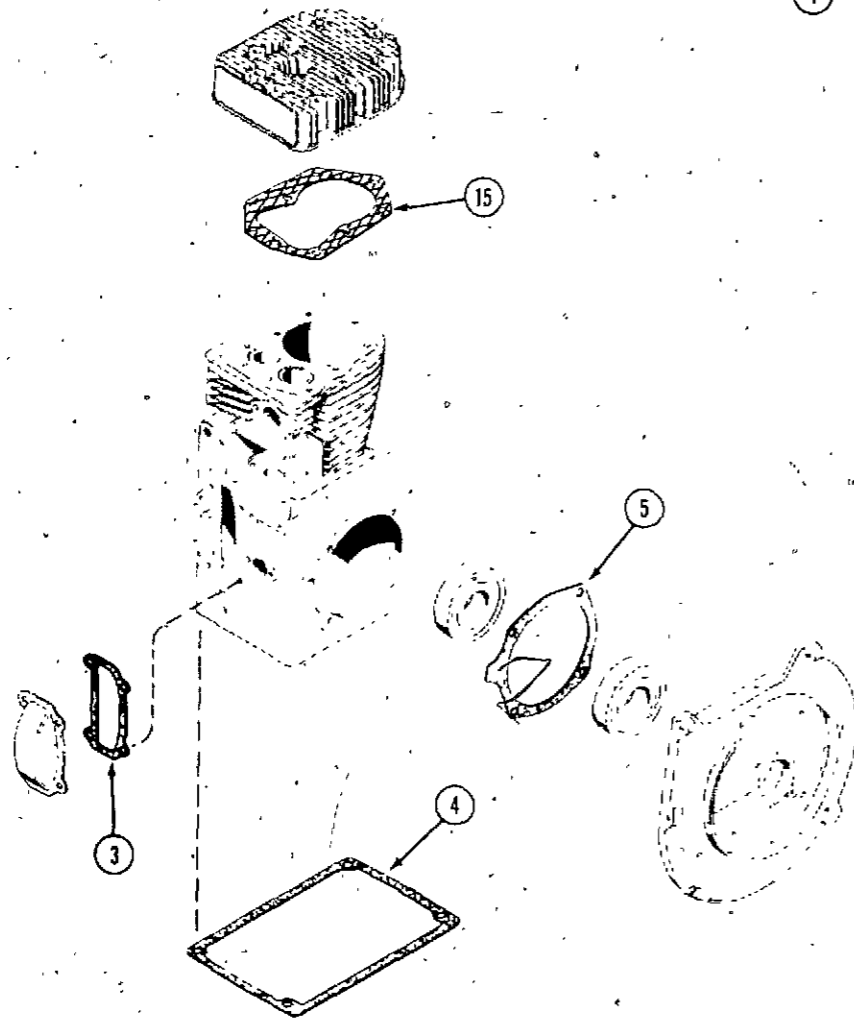

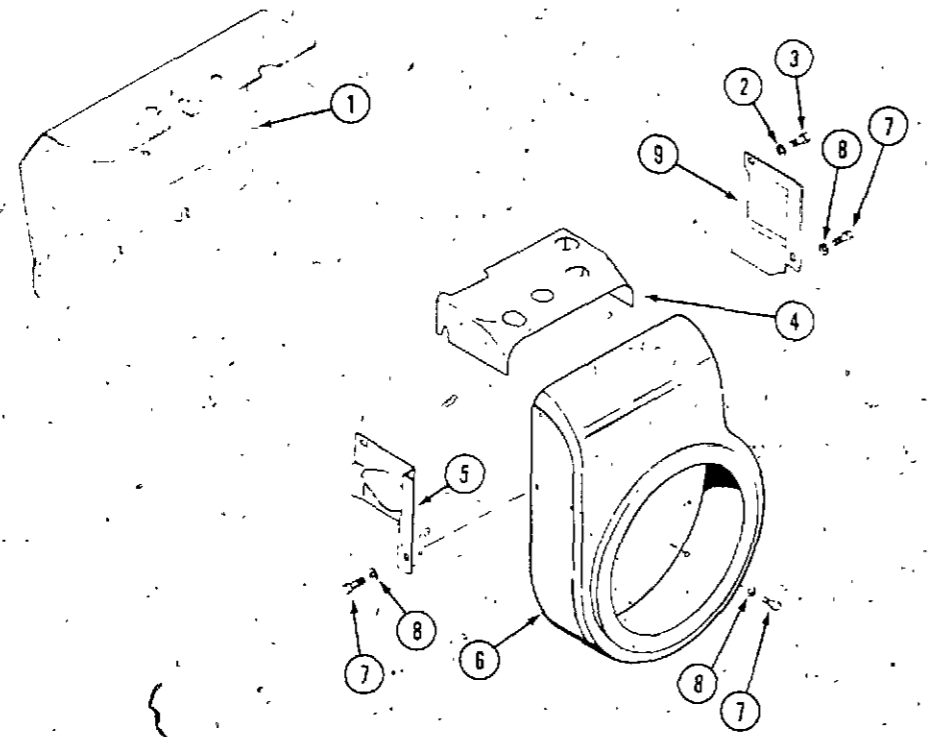

**BAFFLES AND SHROUDS**

REF.	PART NO.	DESCRIPTION	REQ'D
1	C 26985	DEFLECTOR - engine air	1
2	192- 19	LOCK WASHER - 1/4" zinc plated	2
3	113- 1	BOLT - 1/4" x 1-1/2" NC hex, zinc plated	2
4	KO 237520	BAFFLE - cylinder head	1
5	KO 235652	BAFFLE - carburetor side, air (use before S/N 14033980) shown	1
5	C 27280	BAFFLE - carburetor side, air (use S/N 14033980 and after)	1
6	C 24879	HOUSING - blower	1
7	113- 2	BOLT - 1/4" x 3/4" NC hex, zinc plated	4
8	192- 19	LOCK WASHER - 1/4" zinc plated	4
9	KO 236676	BAFFLE - cylinder (use before S/N 14033980) shown	1
9	C 27281	BAFFLE - cylinder (use S/N 14033980 and after)	1

**FUEL SYSTEM**

1	C 23049	CARBURETOR ASSEMBLY - (repairs page 17)	1
2	C 23860	GASKET - carburetor flange	1
3	C 10678	ELBOW - fuel pump and carburetor	2
4	214- 274	CLAMP - hose	4
5	NSS	HOSE - carburetor 5" (use C18274)	1
6	192- 20	LOCKWASHER - 5/16"	2
7	113- 103	BOLT - 5/16" x 1" NC hex	2
8	C 24851	PUMP - fuel, 10 h.p. (includes gasket and washers)	1
9	71- 412	SCREW - 1/4" x 3/4" NC fillister head	2
10	193- 28	LOCKWASHER - 1/4" internal tooth	2
11	KO 275341	GASKET - air horn	1
12	C 23527	LINER - tank	1
13	C 24887	GASKET - fuel pump mounting	1
14	C 10657	ELBOW ASSEMBLY - fuel tank	1
15	A 62079	CLIP - fuel line (optional)	2
16	C 21984	HOSE - fuel line - 38-1/2"	1
17	C 26697	TANK - fuel	1
18	C 11529	CAP - fuel tank (includes insert)	1
19	C 11545	INSERT - fuel cap	1
20	C 14690	CUSHION - fuel tank	2
21	217- 292	ELBOW - 90°, fuel pump inlet	2

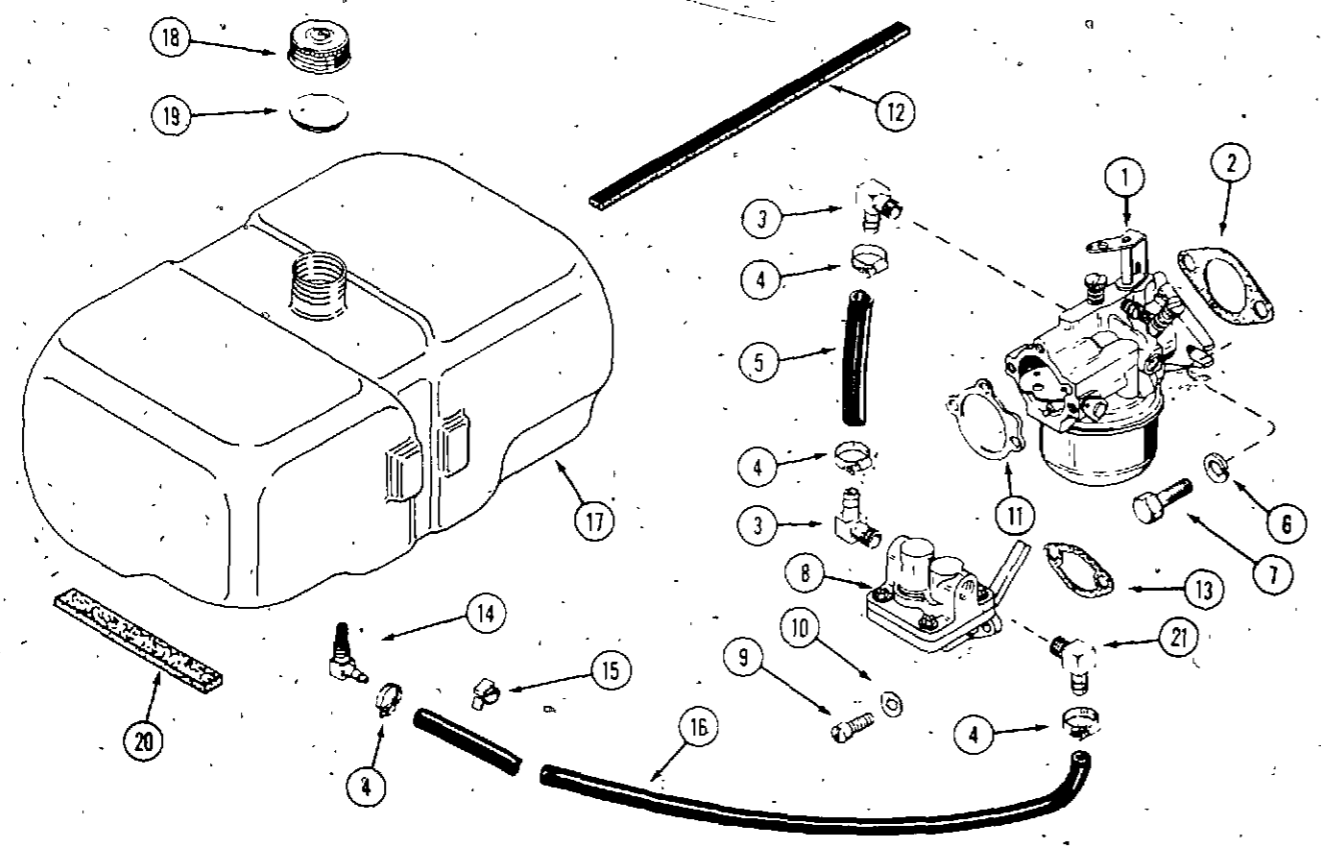



**C 23049 CARBURETOR**

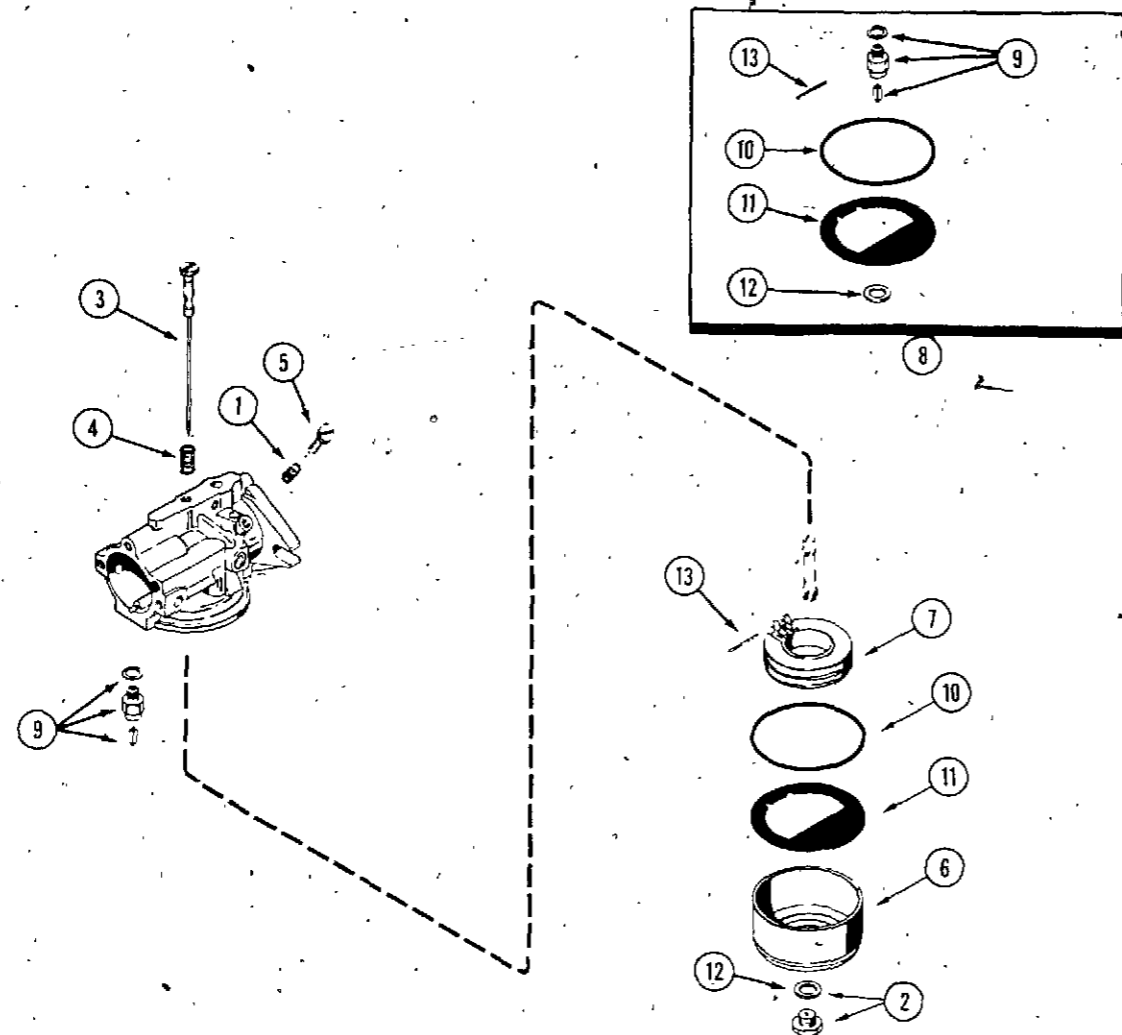

REF.	PART NO.	DESCRIPTION	REQ'D
	C 23049	CARBURETOR ASSEMBLY	1
1	KO 200380	SPRING - tension, idle adjust	1
2	C 26422	SCREW AND GASKET ASSEMBLY - carburetor bowl	1
3	A 72077	NEEDLE - main fuel adjust	1
4	KO 200383	SPRING - main fuel adjust	1
5	A 72099	NEEDLE - idle adjust	1
6	KO 235448	BOWL - carburetor	1
7	KO 200408	FLOAT - carburetor	1
8	A 72103	KIT - carburetor repair	1
9	NSS	INLET NEEDLE AND SEAT ASSEMBLY	1
10	NSS	GASKET - bowl ring	1
11	NSS	GASKET - bowl baffle	1
12	KO 200372	GASKET - bowl screw	1
13	F 19892	PIN - float	1

**MUFFLER SHIELDS**

1	C 22894	MOUNTS AND SHIELD - heat	1
2	113- 118	BOLT - 5/16" x 5/8"	4
3	C 26098	SHIELD - heat	1
4	113- 1	BOLT - 1/4" - 20 x 1/2" hex head, zinc plated	2
5	C 22874	RETAINER - insulation	1
6	C 22903	INSULATION - heat	1
7	129- 19	LOCKWASHERS - 1/4"	2

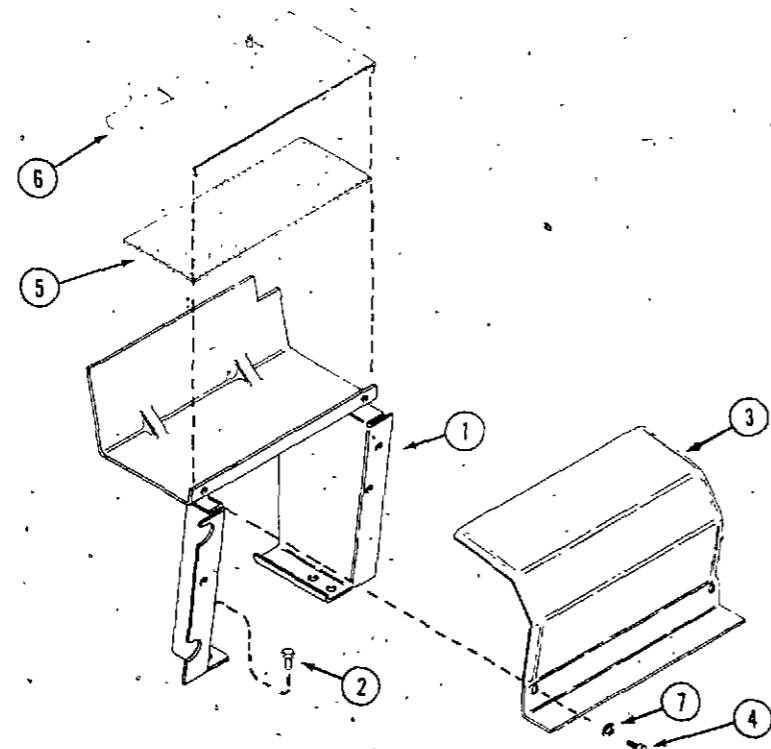

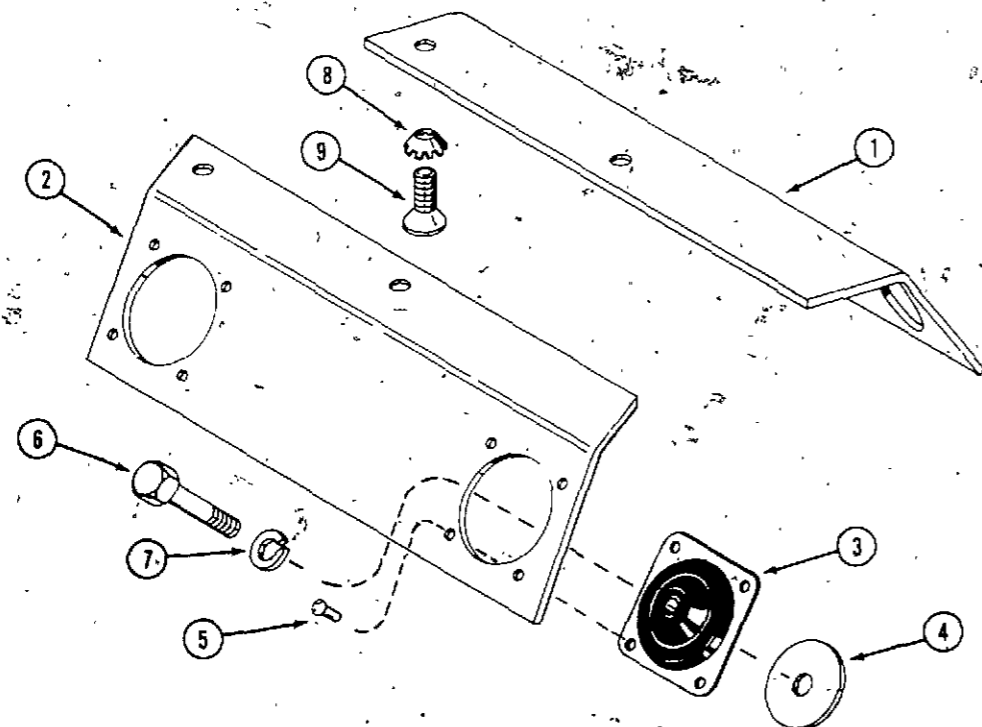
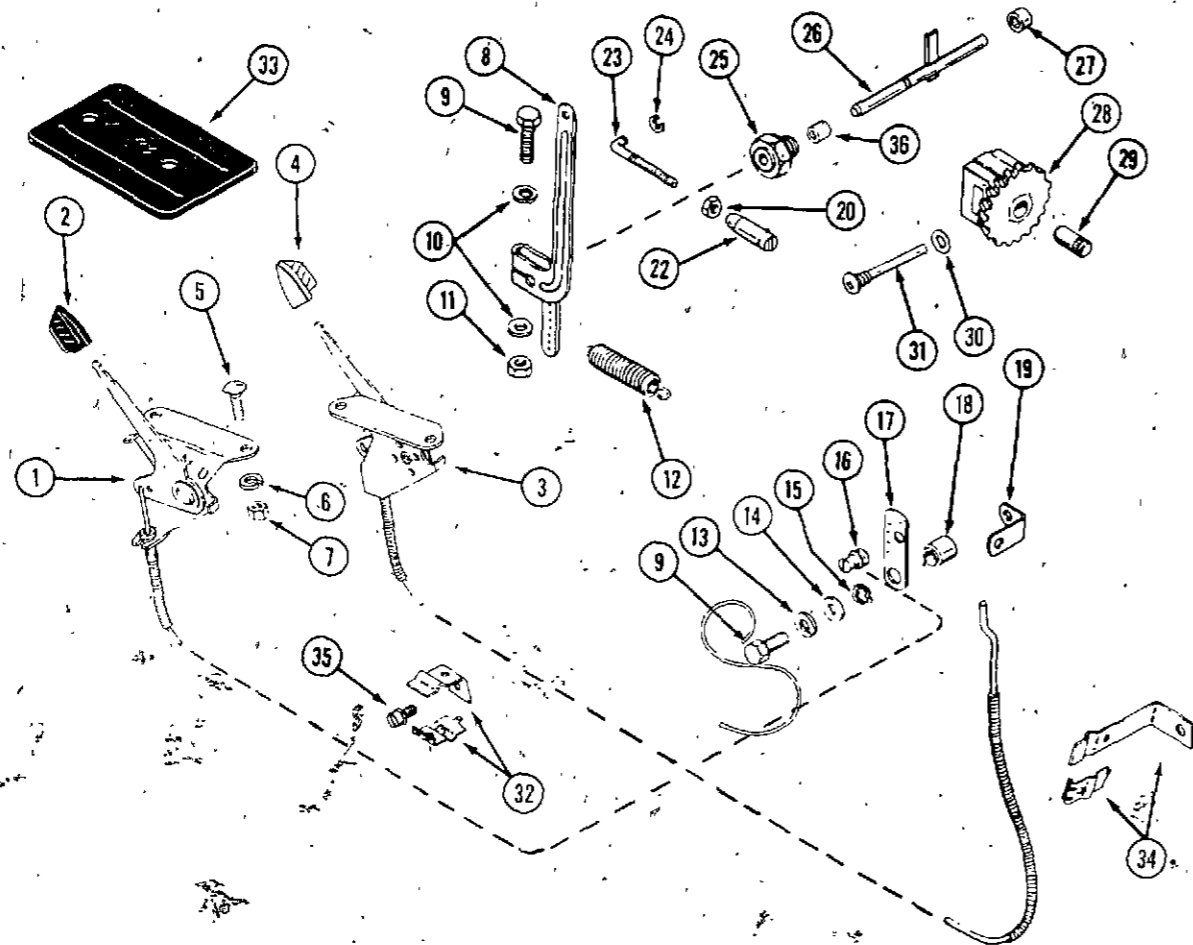

CASE MODEL 210 COMPACT TRACTOR

CHOKE, THROTTLE AND GOVERNOR

REF.	PART NO.	DESCRIPTION	REQ'D
1	C 25603	CONTROL - throttle	1
2	C 12224	HANDLE - throttle control, black	1
3	C 25605	CONTROL - choke	1
4	C 14506	HANDLE - choke control, white	1
5	111- 5	BOLT - 10-24 x 5/8" round head, square neck	2
6	192- 18	LOCKWASHER - #10 Std. plated	2
7	129- 17	NUT - #10 - 24 plated	2
8	KOA 237653	LEVER - governor	1
9	113- 17	BOLT - 1/4" x 1-1/4" NC hex	2
10	195- 518	WASHER - 1/4" plated	2
11	129- 101	NUT - 1/4" hex	1
12	KO 235496	SPRING - governor	1
13	92- 4	LOCKWASHER - 1/4" plated	1
14	C 18098	WASHER - thrust	1
15	KO 275690	WASHER - wavy	1
16	H 43034	CLAMP - swivel, wire	1
17	KO 235086	LEVER - speed control	1
18	KO 235085	SPACER - speed control bracket	1
19	KO 235084	BRACKET - high speed stop	1
20	129- 37	NUT - #10 - 32 hex	1
22	C 25020	JOINT - ball	1
23	KO 235277	ROD - throttle	1
24	49485	RING - retaining, throttle rod	1
25	KO 235476	BUSHING - governor cross shaft	1
26	C 23126	SHAFT ASSEMBLY - governor cross	1
27	V 34418	BEARING - needle, governor shaft	1
28	V 34419	GEAR ASSEMBLY - governor	1
29	KO 235125-S	SHAFT - governor stub	1
30	C 18099	WASHER - governor stop pin	1
31	V 34416	PIN - governor stop	1
32	KOA 237559	BRACKET - throttle cable	1
33	C 23032	PAD - rubber (also requires C24511 stiffener)	1
34	KOA 236919	BRACKET - choke cable	1
35	V 34421	SCREW - #10 x 3/8" NC fillister head, sems	1
36	E 78369	SPACER - shaft (used engine S/N 3173783 and after)	1

ENGINE MOUNTING PLATE

1	C 17717	PLATE - engine mount, L.H.	1
2	C 22904	PLATE - engine mount, R.H.	1
3	C 18793	MOUNT - engine	4
4	D 22988	WASHER - snubbing	4
5	151- 544	RIVET - semi tubular	16
6	113- 219	BOLT - 3/8" x 2" NC hex	4
7	192- 21	LOCKWASHER - 3/8"	4
8	193- 56	LOCKWASHER - 3/8" countersunk external tooth	4
9	164- 50	BOLT - flat head, hex. socket	4

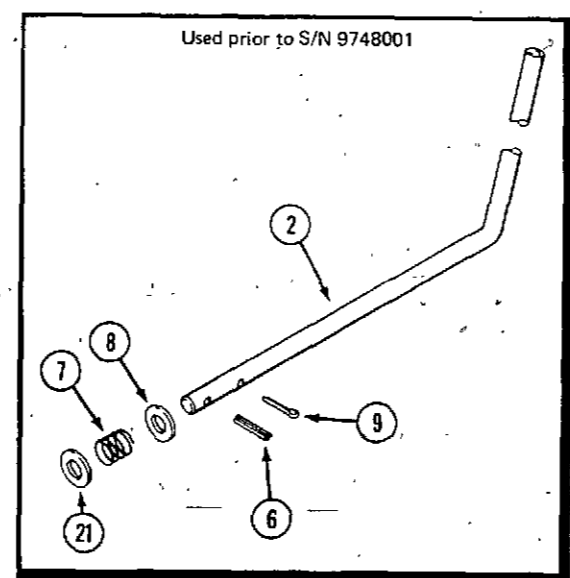
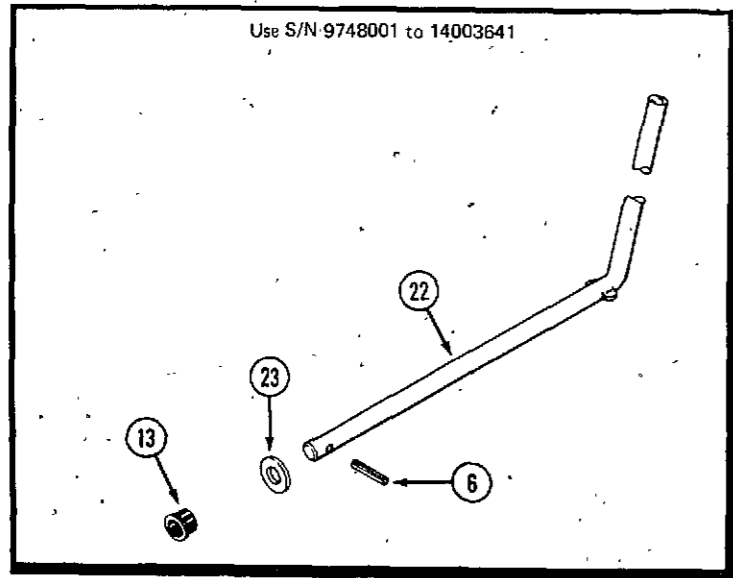
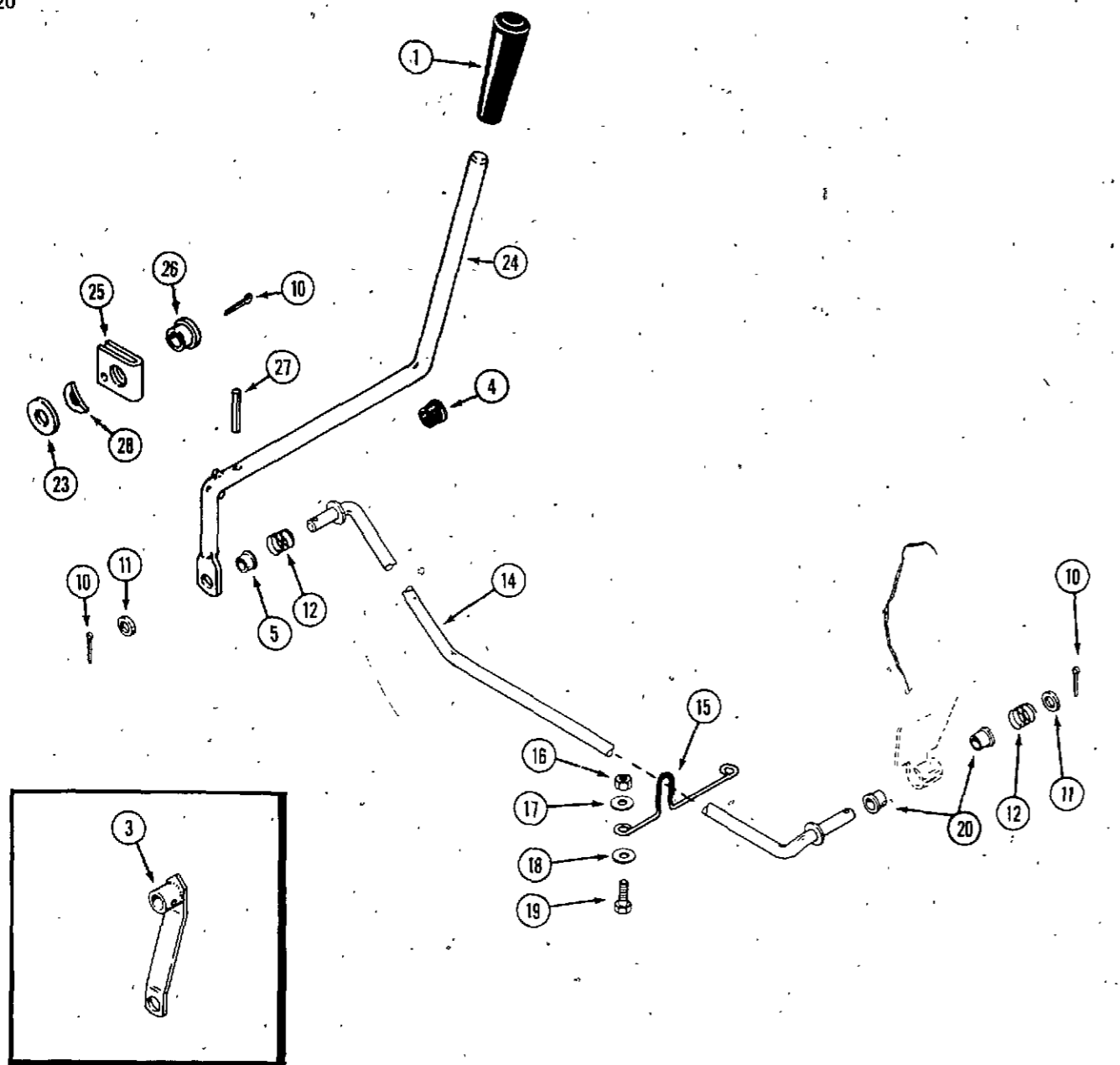

PTO CLUTCH LINKAGE

REF.	PART NO.	DESCRIPTION	REQ'D
1	A 37247	KNOB - lever, PTO	1
2	NSS	LEVER - PTO engaging (use C25013 and 195-533 prior to S/N 9748001)	1
3	C 24792	ARM ASSEMBLY - PTO (used prior to S/N 9733539)	1
3	C 24872	ARM ASSEMBLY - PTO (used S/N 9733539 to 14003641)	1
4	353- 462	BUSHING - lever, dash tower	1
5	C 20093	BUSHING - fliplock	1
6	138- 96	PIN - roll 3/16" x 1"	1
7	C 20036	SPRING - lever, PTO	1
8	A 39519	WASHER - nylon	1
9	132- 91	PIN - cotter 3/16" x 1"	1
10	132- 310	PIN - cotter 1/8" x 1"	2
11	C 14906	WASHER - nylon 3/8"	2
12	C 19867	SPRING - clutch rod	2
13	353- 442	BUSHING - heyco	1
14	C 20107	ROD - clutch	1
15	C 19767	GUIDE - clutch rod	1
16	131- 1181	NUT - lock 3/8" N.C. hex	2
17	195- 104	WASHER - 3/8"	2
18	195- 137	WASHER - spacer	2
19	113- 207	BOLT - 3/8" x 1" N.C. hex	2
20	C 20053	BUSHING - nylon	2
21	195- 2069	WASHER - 5/8"	1
22	C 25013	LEVER - PTO	1
23	195- 533	WASHER - 1/2"	1
24	C 26265	LEVER - PTO engaging	1
25	C 26264	BRACKET - support, PTO lever	1
26	C 26266	BUSHING - flange, nylon	1
27	138- 63	PIN - roll 1/8" x 1-1/4"	1
28	H 202325	WASHER - spring	1

CLUTCH ASSEMBLY (PTO)

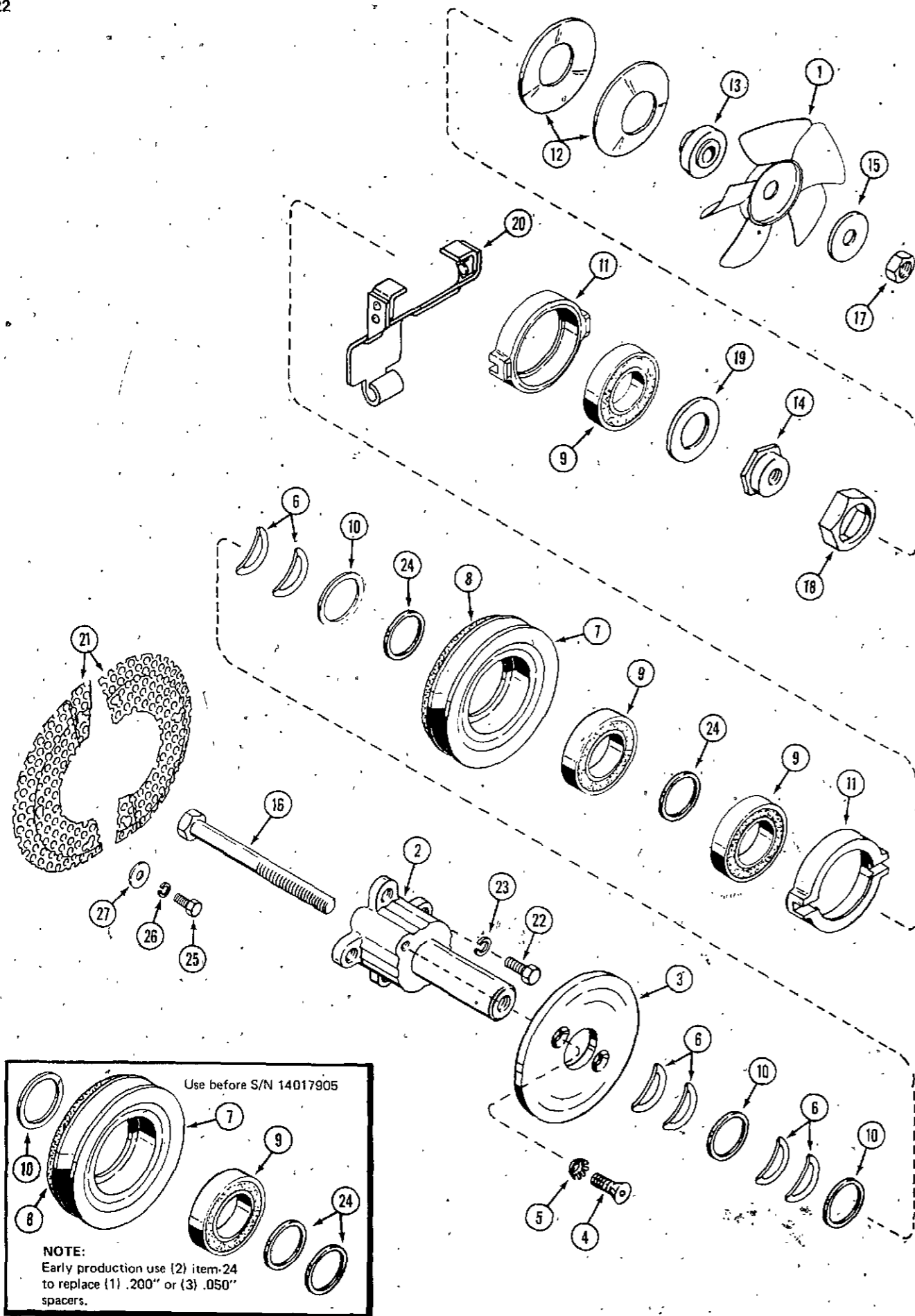

REF.	PART NO.	DESCRIPTION	REQ'D
	C 27150	CLUTCH AND FAN ASSEMBLY	1
1	C 16616	FAN - cooling (not required)	1
2	C 23677	HUB - clutch	1
3	C 15718	PLATE - clutch	1
4	164- 40	BOLT - 5/16" - 18 x 3/4"	2
5	193- 76	LOCKWASHER - 5/16" countersunk external tooth	2
6	C 15515	WASHER - spring	6
7	C 26353	KIT - pulley and disc assembly (includes item 24)	1
8	C 23740	KIT - friction disc	1
9	C 23245	BEARING - ball	3
10	C 15557	WASHER - spacer .050	3
11	C 23033	CAM - clutch	2
12	C 16786	SPRING - clutch load	2
13	C 23630	SPACER - hub	1
14	C 23625	NUT - adjust	1
15	O 2815N	WASHER - fan 17/32"	1
16	C 24743	BOLT - 1/2" - 20 x 5-1/2" NF	1
17	129- 125	NUT - 1/2" - 20 NF	1
18	C 23627	GUIDE - adjusting nut	1
19	C 23624	WASHER - spacer	1
20	C 26166	ARM - engaging	1
21	C 26758	SCREEN - grass	1
22	113- 207	BOLT - 3/8" - 16 x 1" NC	4
23	192- 21	LOCKWASHER - 3/8"	4
24	C 26346*	SPACER - washer .100" (see note on opposite page for early production)	2
25	113- 2	BOLT - 1/4" x 5/8"	4
26	192- 19	LOCKWASHER - 1/4"	4
27	195- 518	WASHER - .281" x .625"	4

\*use S/N 14017905 and after  
 on some late production, item 24 is replaced by  
 (2) .050" spacers. Use item 24 for service.

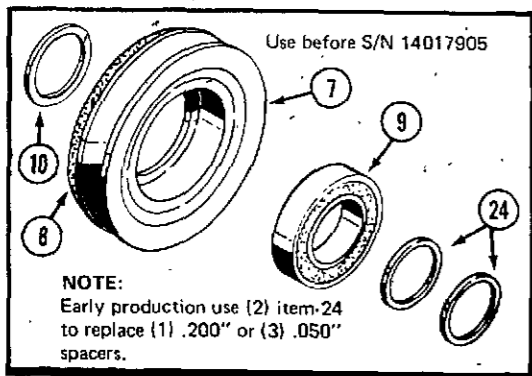

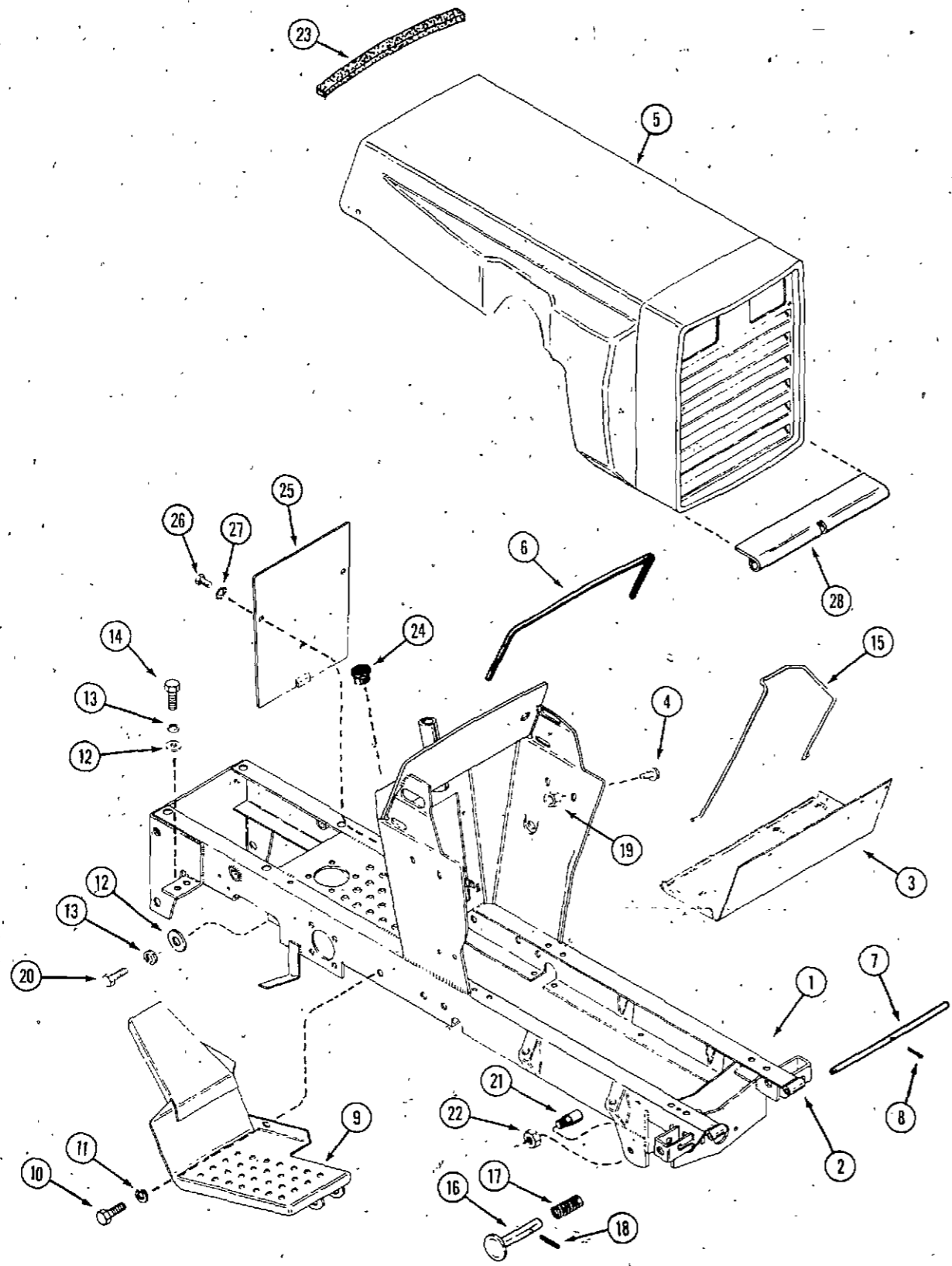

HOOD, FRAME AND GRILLE

REF.	PART NO.	DESCRIPTION	REQ'D
1	C 24770	FRAME - main (also requires C24872 arm prior to S/N 9733539) (used before S/N 9760975)	1
1	NSS*	KIT - frame, main (use S/N 9760975 to 14003736)	1
1	C 26939	FRAME - main (use S/N 14003736 and after)	1
2	C 22023	SPACER - hood hinge mtg.	2
3	C 22817	TRAY - battery	1
4	121- 106	SCREW - 5/16" x 1/2" whizlock	4
5	C 22775	HOOD AND GRILLE ASSEMBLY - (use before S/N 14033980)	1
5	C 26815	HOOD AND GRILLE - (use S/N 14033980 and after) shown	1
6	C 18153	CHANNEL - instrument panel liner	1
7	C 16362	ROD - hood hinge	1
8	132- 46	PIN - cotter 1/8" x 3/4"	1
9	C 18890	PAD - foot L.H. (used before S/N 9760975)	1
9	C 18150	PAD - foot R.H. (used before S/N 9760975)	1
9	C 25315	PAD - foot L.H. (used S/N 9760975 and after)	1
9	C 25316	PAD - foot R.H. (used S/N 9760975 and after) shown	1
10	113- 113	BOLT - 5/16" x 7/8" NC hex	3
11	192- 20	LOCKWASHER - 5/16"	3
12	195- 104	WASHER - 3/8" flat	7
13	192- 21	LOCKWASHER - 3/8"	7
14	113- 206	BOLT - 3/8" x 3/4" NC hex	4
15	C 16239	STRAP - battery hold down	1
16	C 16373	PIN - latch	2
17	C 24137	SPRING - latch	2
18	138- 2073	PIN - roll 3/16" x 1-1/4"	2
19	129- 102	NUT - 5/16" NC hex	4
20	113- 207	BOLT - 3/8" x 1" NC hex	3
21	C 18733	PIN - attachment	2
22	131- 1318	NUT - lock 1/2" - #20 NF jam	2
23	C 23527	LINER - hood	1
24	353- 406	PLUG - instrument panel	1
25	C 24822	COVER - access (use before S/N 9778826)	1
25	C 26506	COVER - access (use S/N 9778826 and after)	1
26	113- 1	BOLT - 1/4" - 20 x 1/2"	4
27	193- 57	LOCKWASHER - 1/4", internal tooth	4
28	C 16361	HINGE - hood	1

\*use C26377, C26378, C20053(2), 195-103(2) and 131-1181

also requires C26266, C26265, C26264, 195-533, 138-63 and 132-310 before S/N 14003641

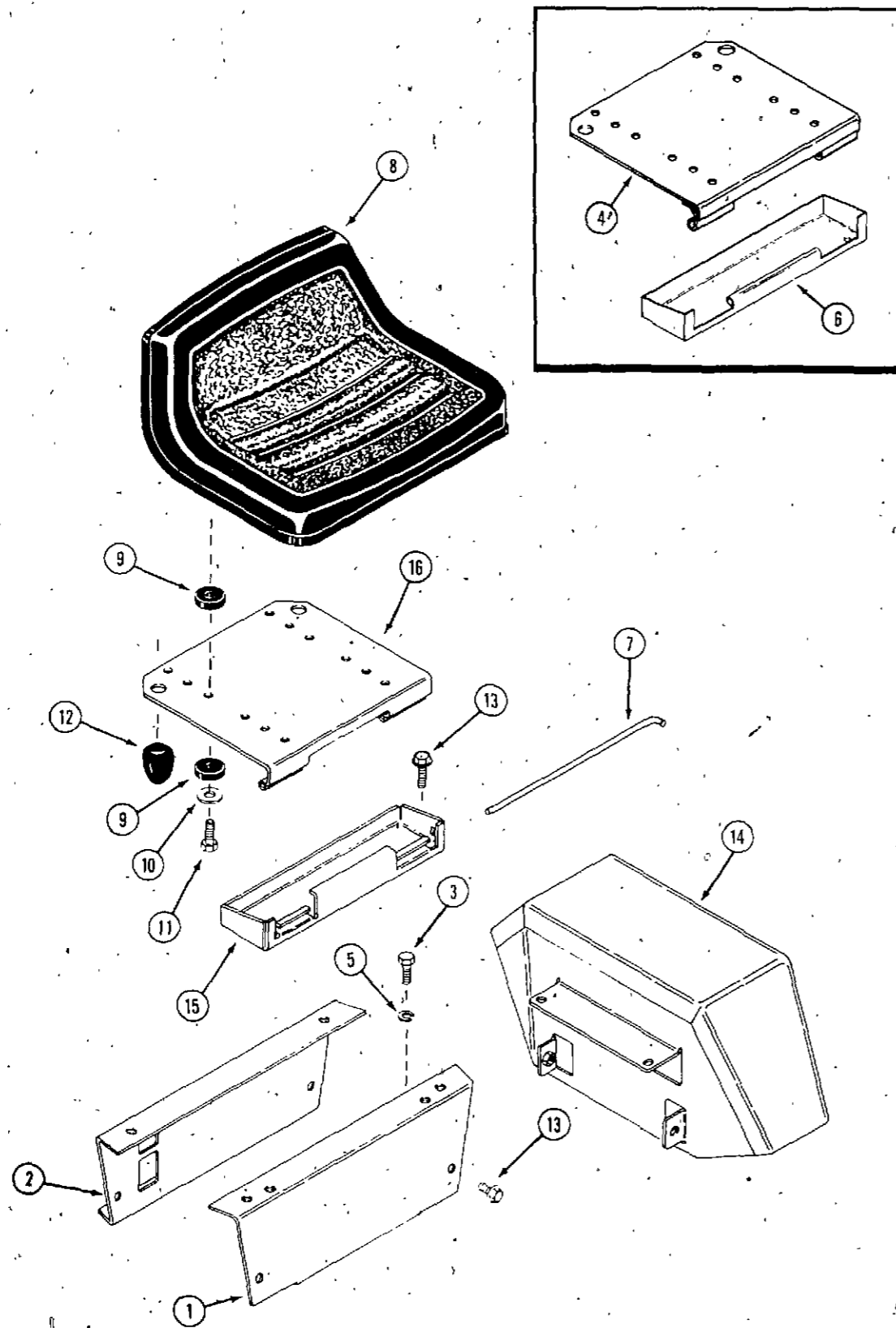

SEAT, FENDERS AND TOOL TRAY

REF.	PART NO.	DESCRIPTION	REQ'D
1	C 26065	SUPPORT - seat, front (use before S/N 14033980)	1
1	C 26823	SUPPORT - seat, front (use S/N 14033980 and after)	1
2	C 26695	SUPPORT - seat, rear (use before S/N 14033980)	1
2	C 26827	SUPPORT - seat, rear (use S/N 14033980 and after)	1
3	113- 424	BOLT - 1/2" x 1" NC hex	4
3	113- 118	BOLT - 5/16" x 5/8" hex	1
4	C 17152	HINGE ASSEMBLY - seat (use before S/N 9779192)	1
5	192- 23	LOCK WASHER - 1/2"	4
5	192- 20	LOCK WASHER - 5/16"	1
6	C 19417	TRAY - tool (use before S/N 9779192)	1
7	C 16429	PIN - seat hinge	1
8	C 26214	SEAT - operators	1
9	D 59705	CUSHION - rubber	8
10	195- 2175	WASHER - 5/16" x 1-1/4" OD, zinc plated	4
11	113- 122	BOLT - 5/16" x 1-1/2"	4
12	C 14534	BUMPER - seat	2
13	121- 106	BOLT - 5/16" x 1/2" flange whizlock	10
14	C 16446	FENDER - L.H. (used before S/N 9760975)	1
14	C 16447	FENDER - R.H. (used before S/N 9760975)	1
14	C 25297	FENDER - L.H. (used S/N 9760975 to 14033980)	1
14	C 25298	FENDER - R.H. (used S/N 9760975 to 14033980)	1
14	C 26831	FENDER - L.H. (use S/N 14033980 and after)	1
14	C 26829	FENDER - R.H. (use S/N 14033980 and after)	1
15	C 26028	TRAY - tool (use S/N 9779192 and after)	1
16	C 26029	HINGE - seat (use S/N 9779192 and after)	1

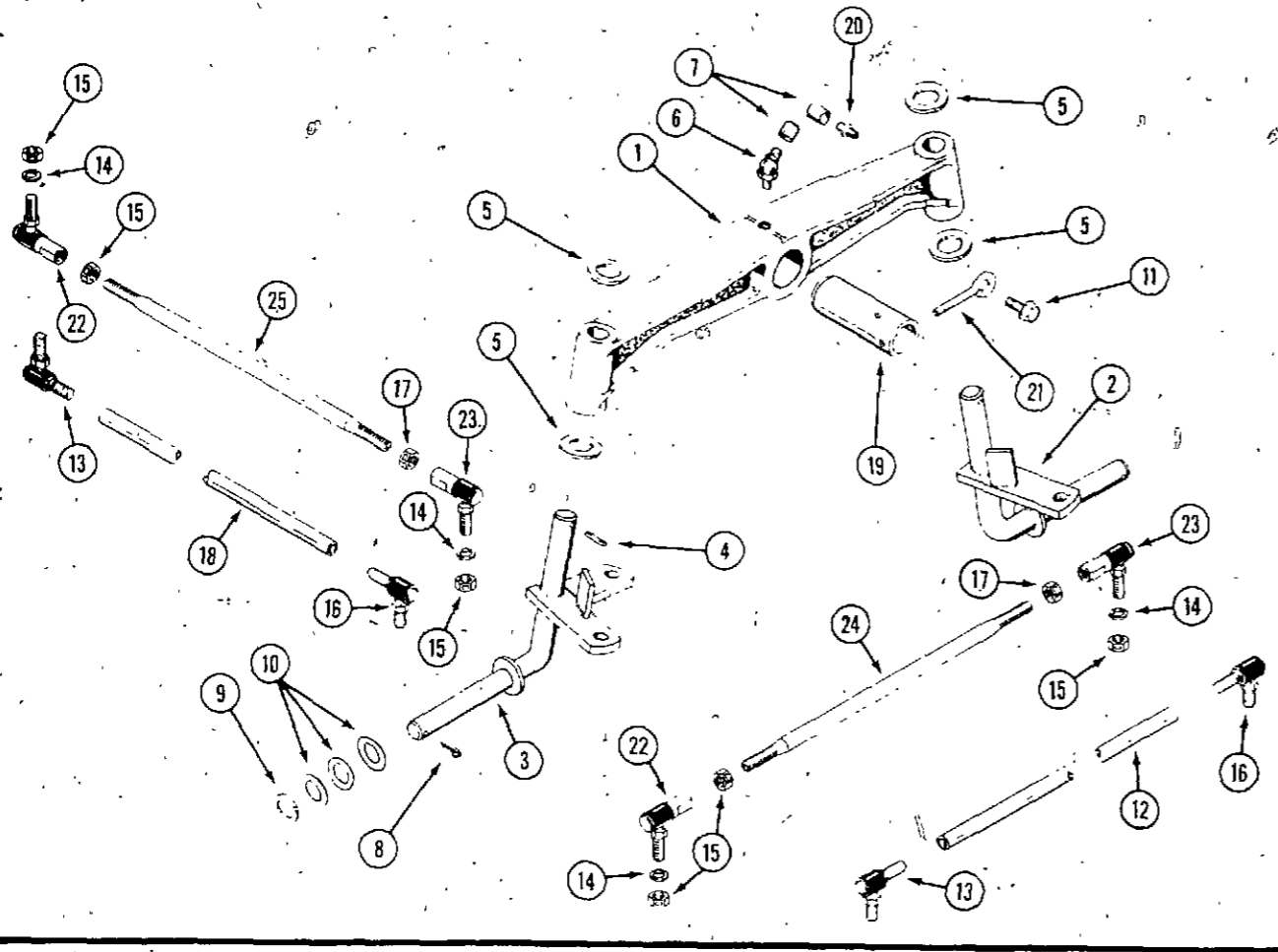

FRONT AXLE

REF.	PART NO.	DESCRIPTION	REQ'D.
1	C 18812	AXLE - front	1
2	C 18777	SPINDLE - left hand	1
3	C 18779	SPINDLE - right hand	1
4	138- 99	PIN - roll	2
5	C 11906	WASHER - thrust	4
6	219- 404	FITTING - lube	1
7	C 13106	COVER - lube fitting	3
8	132- 311	PIN - cotter 5/32" x 1-1/4"	2
9	C 12975	WASHER - wheel spindle	2
10	A 30881	WASHER - wheel spacer	6
11	187- 1910	BOLT - 3/8" NC idented hex head	1
12	C 21530	TIE ROD - (use before S/N 9779260)	1
13	C 21526	BALL JOINT - 1/2" R.H. thread (use before S/N 9779260)	2
14	192- 23	LOCKWASHER - 1/2" zinc plated	3
15	129- 165	NUT - 1/2" NF hex R.H. thread	6
16	C 21527	BALL JOINT - 1/2" L.H. thread (use before S/N 9779260)	2
17	129- 365	NUT - 1/2" NF hex L.H. thread	2
18	NSS	ROD - drag link (service with C 22992 kit) (use before S/N 9779260)	1
19	C 22568	TUBE - axle pivot	1
20	219- 17	FITTING - lube	2
21	C 22278	PIN - retaining	1
22	C 12102	BALL JOINT - 1/2" R.H. thread (use S/N 9779260 and after)	2
23	C 13605	BALL JOINT - 1/2" L.H. thread (use S/N 9779260 and after)	2
24	C 25856	TIE ROD - (use S/N 9779260 and after)	1
25	C 25857	ROD - drag link (use S/N 9779260 and after)	1

FRONT AND REAR WHEELS

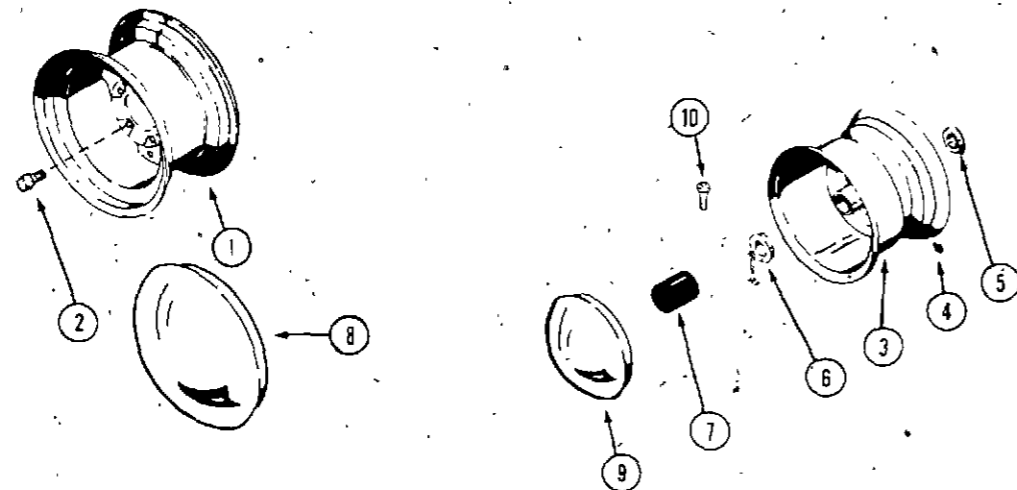

1	C 24435	WHEEL - rear, 5 bolt (white)	2
2	C 10314	BOLT - rear wheel	10
3	C 24433	WHEEL - front (white) (includes bearings)	2
4	219- 403	FITTING - lube	2
5	C 12110	BEARING - wheel, inner	2
6	C 12110	BEARING - wheel, outer	2
7	C 26021	CAP - plastic, front	2
8	A 70185	CAP - hub, rear (optional)	2
9	A 70062	CAP - hub, front wheel (optional)	2
10	A 37109	STEM - valve	4

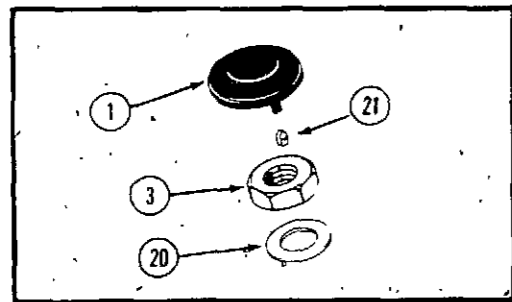

Use before S/N:  
14003693

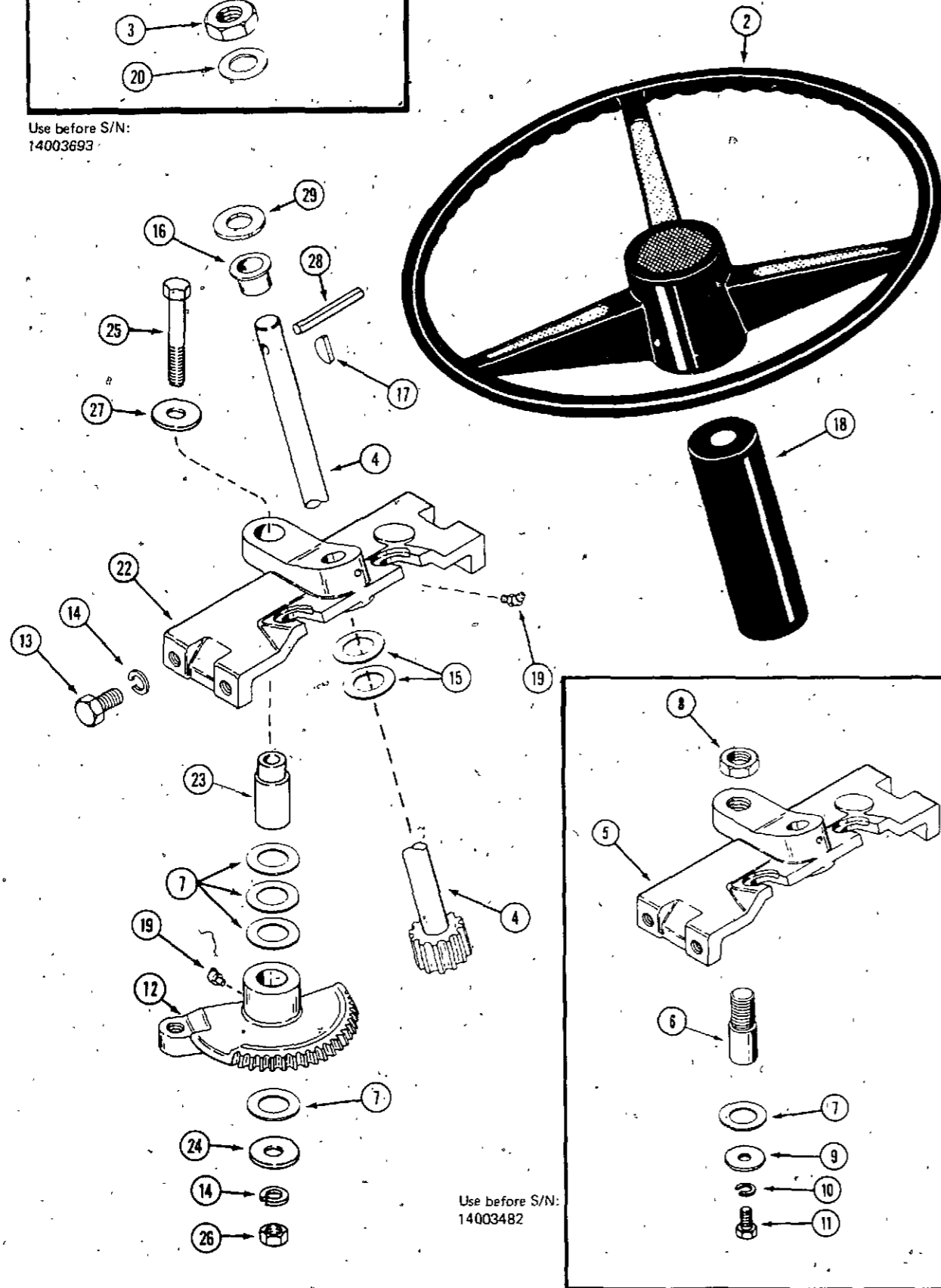

Use before S/N:  
14003482

STEERING GEAR

REF.	PART NO.	DESCRIPTION	REQ'D
1	C 16945	CAP - steering wheel	1
2	C 18014	WHEEL - steering (use before S/N 14003693)	1
2	C 26325	WHEEL - steering (use S/N 14003693 and after)	1
3	131- 1113	NUT - lock 5/8"	1
4	NSS	SHAFT - steering (use C26325, C26326, 138-143 before S/N 14003693)	1
4	C 26326	SHAFT - steering (use S/N 14003693 and after)	1
5	NSS	SUPPORT - steering gear (use items 14, 22, 23, 24, 25, 26 and 27)	1
6	C 14200	PIN - pivot	1
7	C 14201	WASHER - shim	4
8	129- 148	NUT - jam 3/4"	1
9	195- 2021	WASHER	1
10	192- 20	LOCKWASHER - 5/16" zinc plated	1
11	113- 102	BOLT - 5/16" x 7/8" NC hex	1
12	C 18711	GEAR - steering	1
13	113- 206	BOLT - 3/8" x 3/4" NC hex	4
14	192- 21	LOCKWASHER - 3/8"	4
15	195- 2069	WASHER - 5/8" zinc plated	2
16	C 15006	BUSHING - flanged nylon	1
17	126- 16	KEY - Woodruff 3/16" x 3/4" (use before S/N 14003693)	1
18	C 24098	TUBE - steering	1
19	219- 404	FITTING - lube 45°	2
20	C 12975	WASHER - 5/8"	2
21	C 18017	CLIP - tinnerman (use with C18014 steering wheel)	2
22	C 25788	SUPPORT - steering gear	1
23	C 25787	PIN - pivot	1
24	195- 2029	WASHER - 7/16" x 1.25"	2
25	113- 241	BOLT - 3/8" - 16 x 3" hex	1
26	129- 103	NUT - 3/8" - 16 hex	1
27	195- 137	WASHER - 1-1/8" O.D.	1
28	138- 143	PIN - roll 1/4" x 2-1/4" (use S/N 14003693 and after)	1
29	195- 541	WASHER - 5/8"	1
	C 13106	COVER - lube fitting	2

UAR  
2



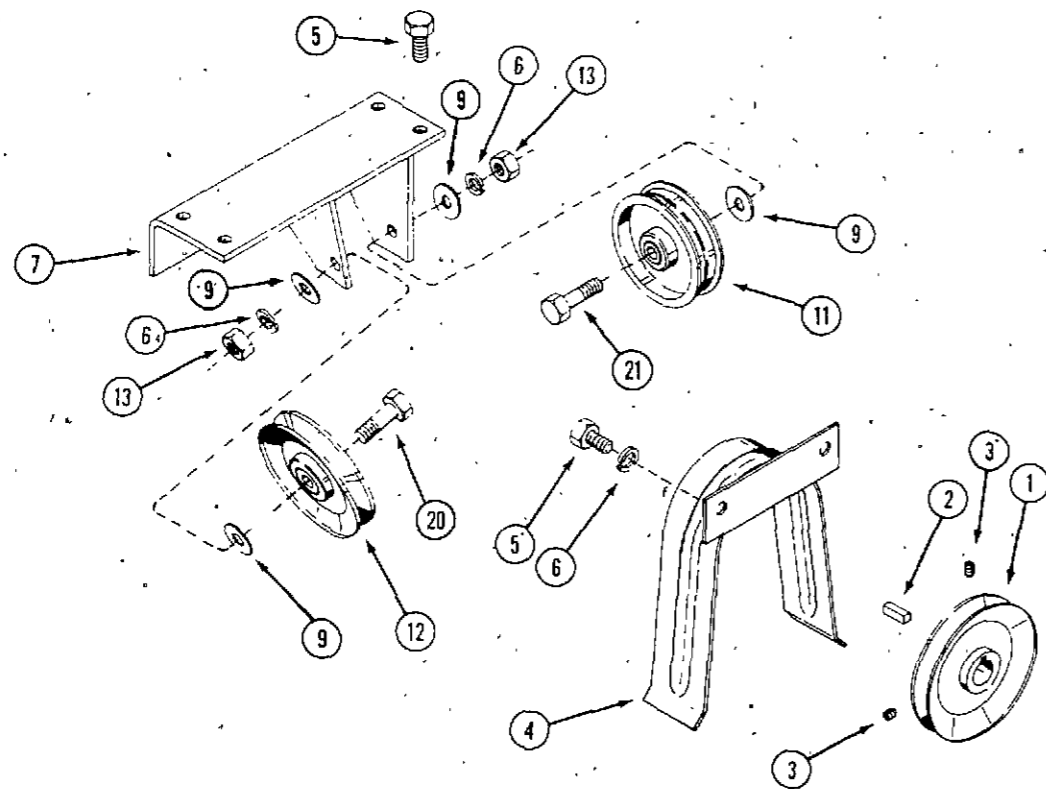
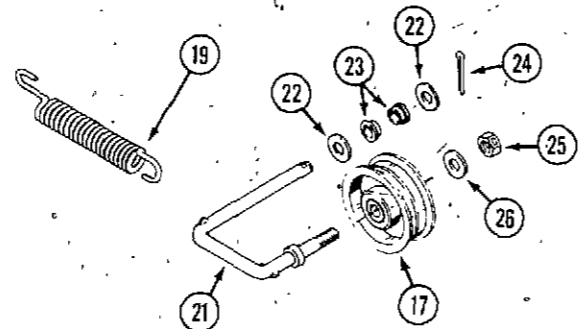
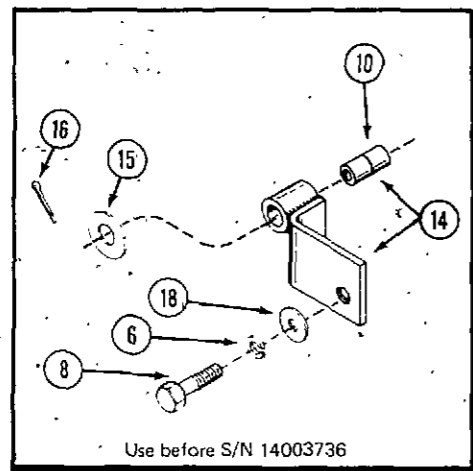

DRIVE PULLEY AND IDLERS

REF.	PART NO.	DESCRIPTION	REQ'D
1	C 23522	PULLEY - engine	1
2	W 5063-S	KEY - square 1/2" x 3/4"	1
3	178- 858	SETSCREW - 5/16" x 3/8"	2
4	C 23723	GUARD - belt (early production)	1
5	113- 206	BOLT - 3/8" x 3/4" NC hex	6
6	192- 21	LOCKWASHER - 3/8"	6
7	C 18974	BRACKET - drive, idler mounting	1
8	113- 208	BOLT - 3/8" x 1-1/4" NC hex	1
9	195- 104	WASHER - 3/8" flat	4
10	R 30880	BUSHING - arm, idler	2
11	C 18966	PULLEY - idler, flat	1
12	C 23531	PULLEY - idler, V-groove	1
13	129- 103	NUT - 3/8" NC hex	2
14	C 23530	ARM AND BUSHING ASSEMBLY - belt tension, idler (includes item 10)	1
15	195- 2069	WASHER - 5/8" flat	1
16	132- 310	PIN - cotter 1/8" x 1"	1
17	C 23535	PULLEY - idler, flat	1
18	195- 104	WASHER - 3/8" flat	1
19	C 19553	SPRING - idler	1
20	113- 209	BOLT - 3/8" x 1-1/2" N.C. hex	2
21	C 26378	ARM - idler mounting	1
22	195- 525	WASHER - 3/8"	2
23	C 20053	BUSHING - nylon	2
24	132- 46	PIN - cotter 1/8" x 3/4"	1
25	131- 1181	NUT - lock 3/8" - 16	1
26	195- 104	WASHER - 3/8"	1

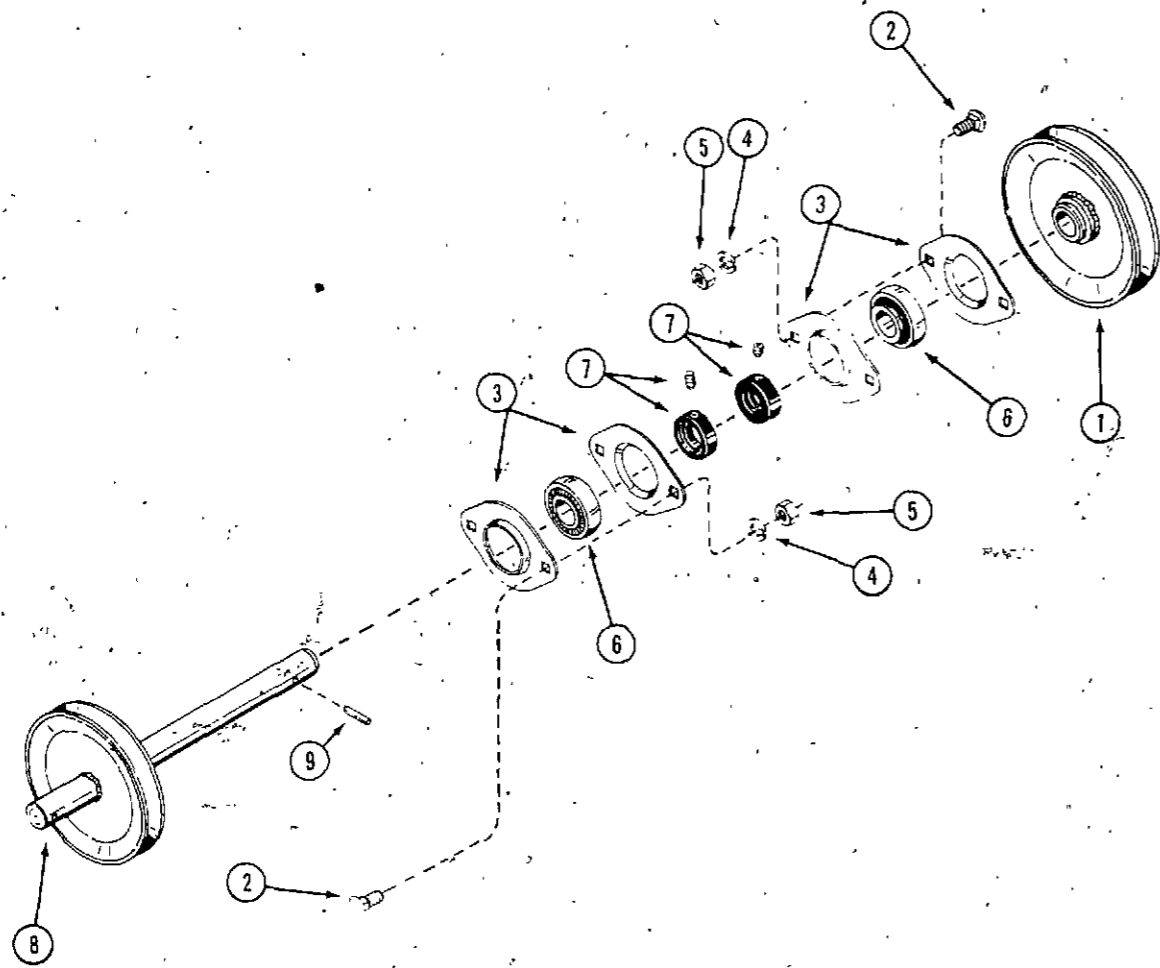

**DRIVE SHAFT**  
(USED BEFORE S/N 9760975)\*

REF.	PART NO.	DESCRIPTION	REQ'D
1	C 23516	PULLEY - V-groove	1
2	111- 202	BOLT - round head, square neck 5/16" x 3/4"	4
3	C 15514	FLANGETTE	4
4	192- 20	LOCKWASHER - 5/16"	4
5	129- 102	NUT - 5/16" NC hex	4
6	C 14419	BEARING - 3/4" bore (includes locking collar)	2
7	C 21795	COLLAR - locking (includes set screw)	2
8	C 23467	JACKSHAFT	1
9	138- 2040	PIN - roll 1/4" x 1-1/2"	1

\*C25594 drive shaft kit is available to update unit to current drive shaft assembly.

**DRIVE SHAFT**  
(USED S/N 9760975 AND AFTER)

1	C 23818	FLANGETTE	2
2	113- 118	BOLT - 5/16" x 5/8"	8
3	131- 176	NUT - lock 5/16" x 5/8"	8
4	C 25328	DRIVE SHAFT	1
5	C 23452	PULLEY	1
6	A 70280	BEARING - 3/4"	2
7	C 25324	SPACER	1
8	C 12975	WASHER	5
9	A 21075	KEY - square 3/16" x 5/8"	1
10	D 33544	WASHER	1
11	113- 206	BOLT - 3/8" -16 x 3/4"	1

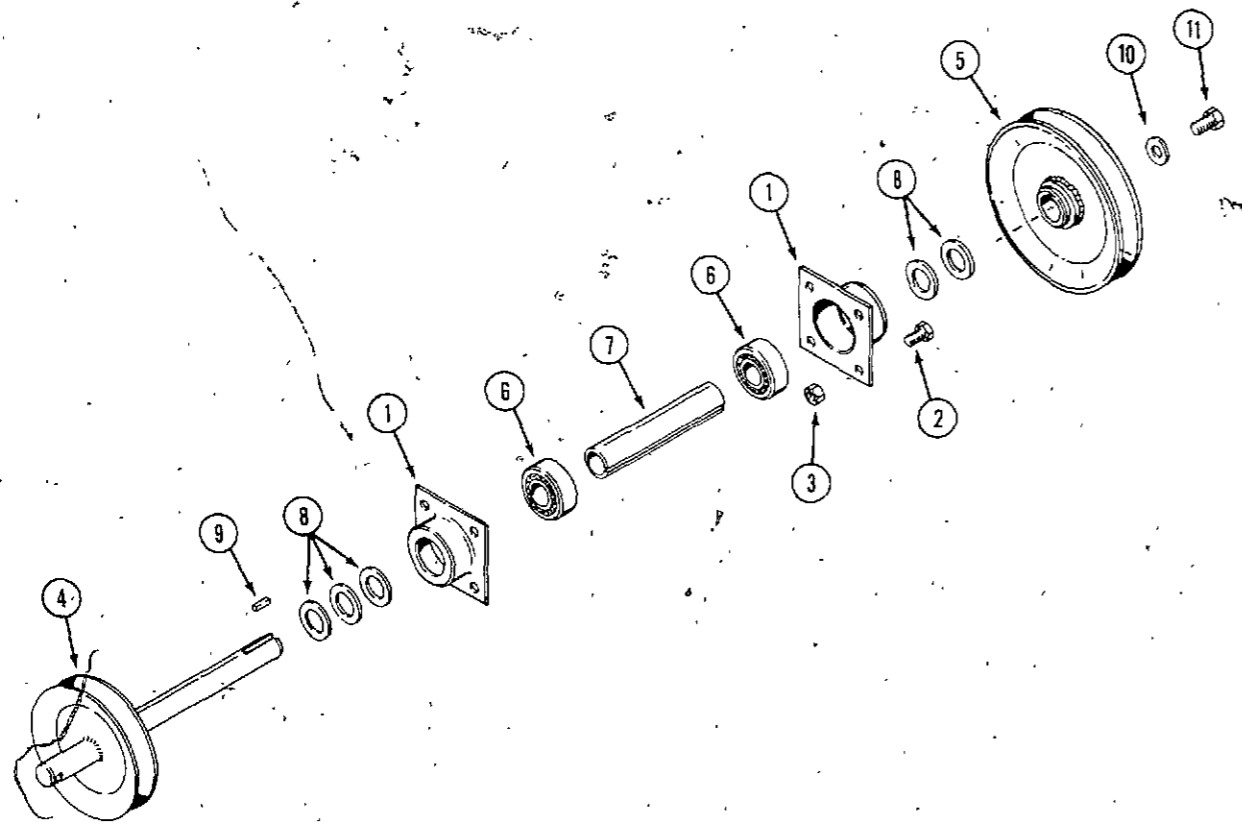

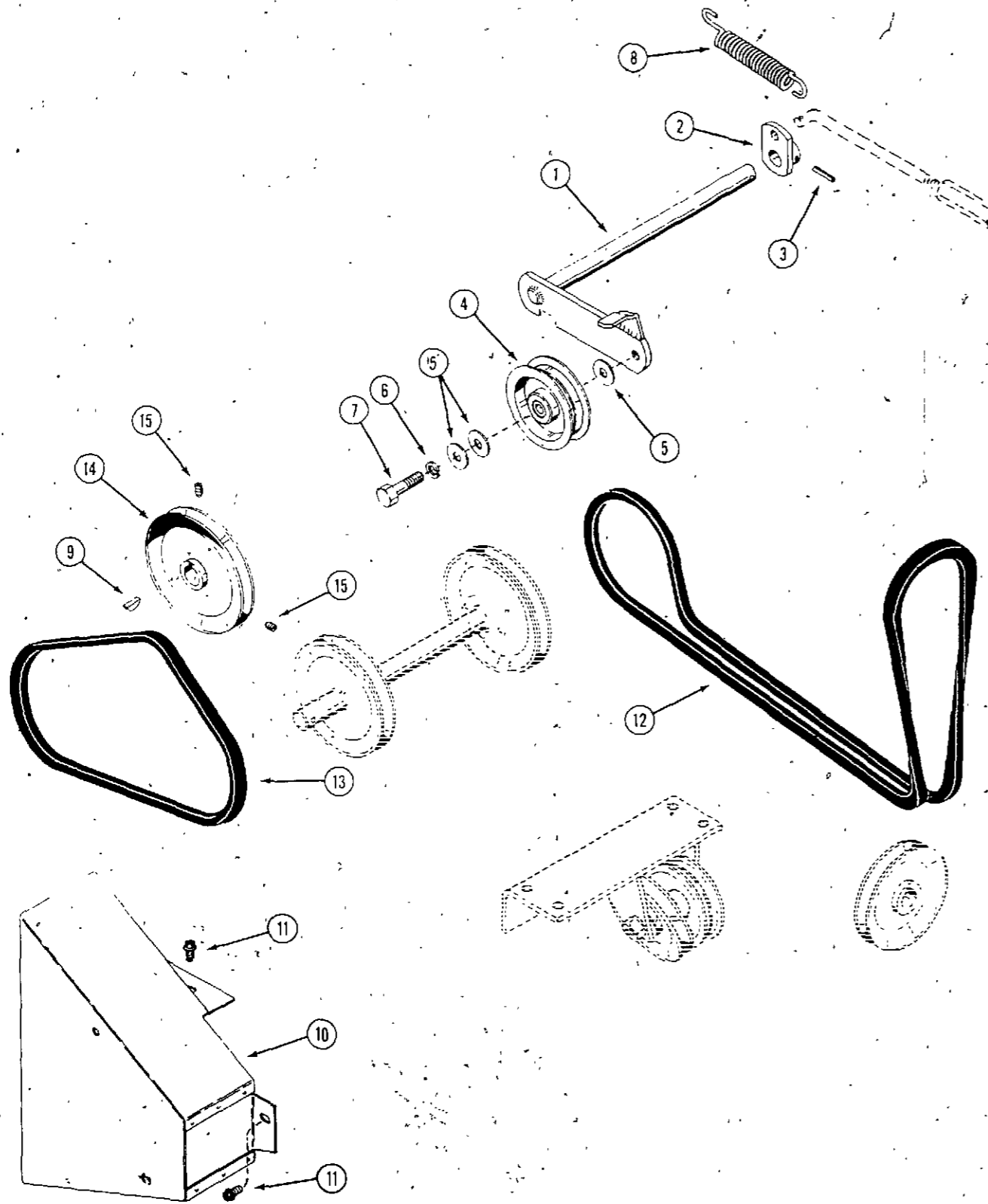

CLUTCH, BELTS AND GUARD

REF.	PART NO.	DESCRIPTION	REQ'D
1	C 25327	SHAFT - clutch idler (used S/N 9760975 and after)	1
1	C 24824	SHAFT - clutch idler (used before S/N 9760975)	1
2	C 18964	LEVER - clutch	1
3	138- 96	PIN - roll 3/16" x 1"	1
4	C 23456	PULLEY - clutch idler	1
5	195- 103	WASHER - 3/8" flat	1
6	192- 21	LOCKWASHER - 3/8"	1
7	113- 208	BOLT - 3/8" x 1-3/4"-NC hex	1
8	C 19553	SPRING - clutch	1
9	126- 16	KEY - Woodruff #9	1
10	C 19397	GUARD - belt (used before S/N 9760975)	1
11	187- 1036	SCREW - 1/4" x 1/2" self tapping	4
12	C 23685	BELT - tractor drive	1
13	C 26437	BELT - clutching	1
14	C 23452	PULLEY - transaxle input	1
15	178- 858	SETSCREW - 5/16" x 3/8" knurled cup point	2

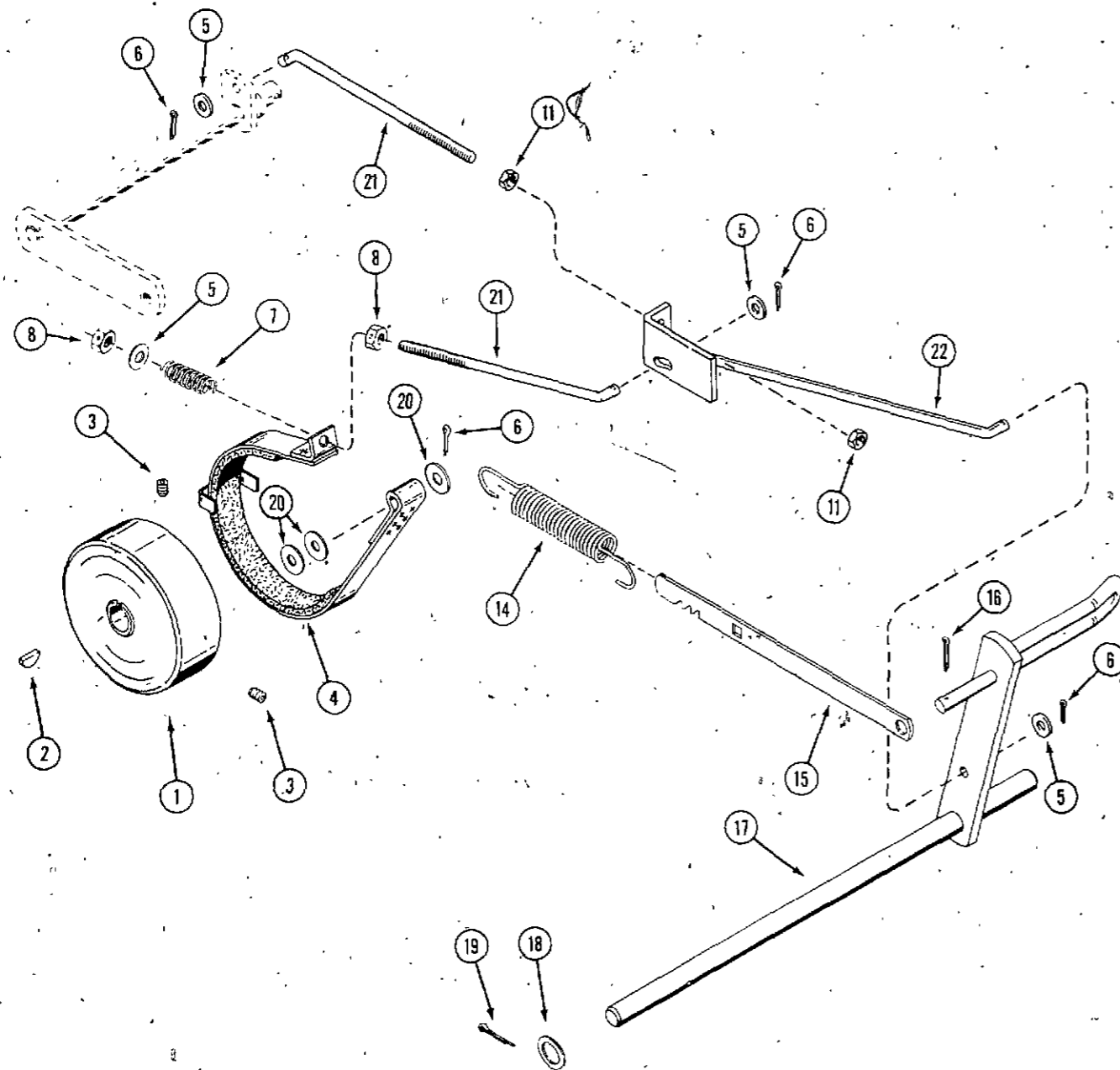
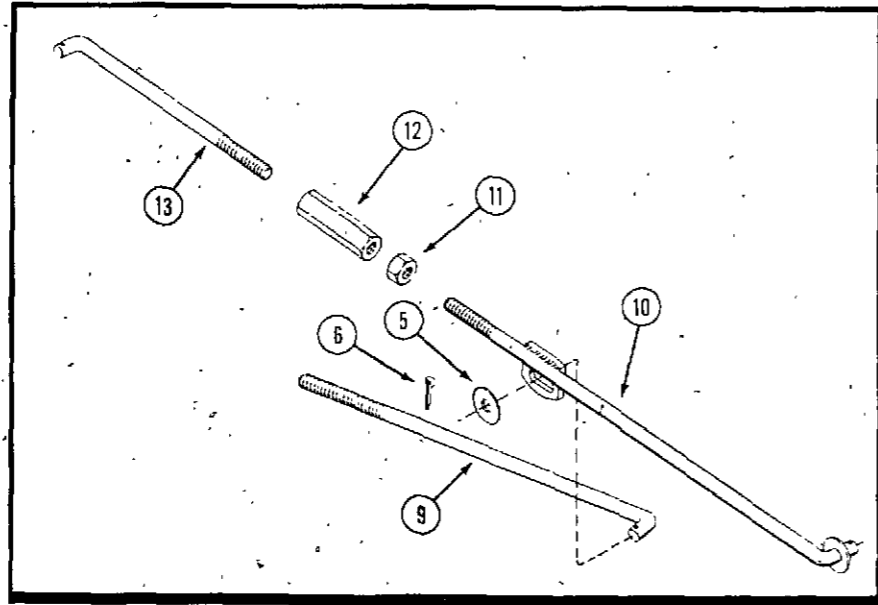

**BRAKE ASSEMBLY**

REF.	PART NO.	DESCRIPTION	REQ'D
1	C 21587	DRUM - brake	1
2	126- 16	KEY - Woodruff No. 9	1
3	178- 858	SETSCREW - 5/16" x 3/8"	1
4	C 21584	BAND ASSEMBLY - brake	1
5	195- 104	WASHER - 3/8" flat	3
6	132- 46	PIN - cotter 1/8" x 3/4"	4
7	L 32763	SPRING - compression	1
8	131- 1181	NUT - lock 3/8" NC hex	2
9	C 18988	LINK - brake (used before S/N 9760975)	1
10	C 18985	LINK - front (used before S/N 9760975)	1
11	129- 103	NUT - 3/8" NC hex	1
12	C 19552	TURNBUCKLE - 3/8" hex NC (used before S/N 9760975)	1
13	C 18986	LINK - clutch, rear (used before S/N 9760975)	1
14	C 16379	SPRING - brake lock	1
15	C 18147	LEVER - brake lock	1
16	132- 310	PIN - cotter	1
17	C 18983	PEDAL ASSEMBLY - brake/clutch (used before S/N 9760975)	1
17	C 25330	PEDAL - brake/clutch (used S/N 9760975 and after)	1
18	C 12975	WASHER - brake shaft	1
19	132- 332	PIN - cotter 1/8" x 1-1/2"	1
20	195- 525	WASHER - 3/8"	4
21	C 25320	LINK - rear clutch on brake (used S/N 9760975 and after)	2
22	C 25323	LINK - forward (used S/N 9760975 and after)	1

C 18956 TRANSAXLE

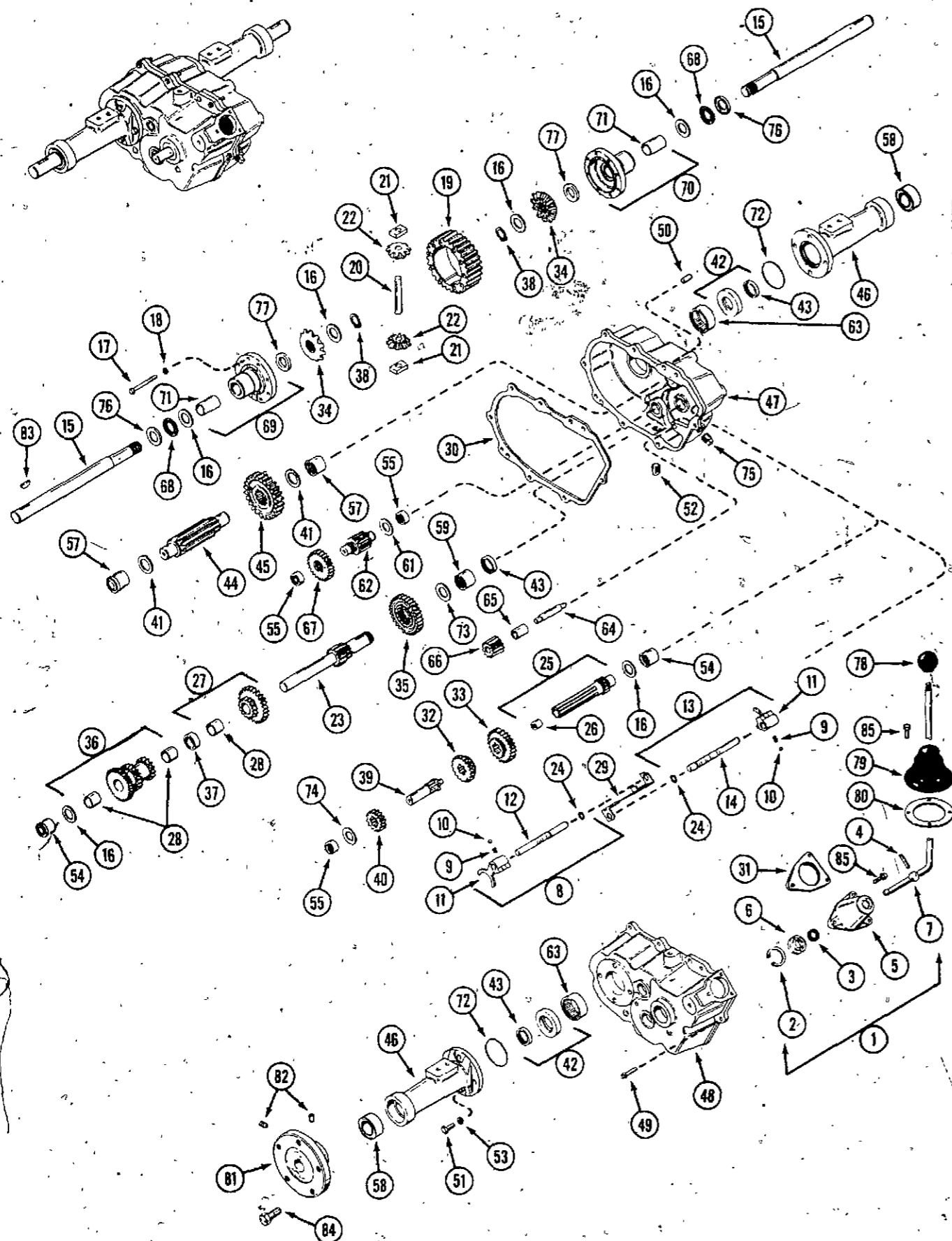

REF.	PART NO.	DESCRIPTION	REQ'D
1	NSS	LEVER AND HOUSING ASSY, shift (includes Ref. 2 thru 7)	1
2	A 32181	RING - snap	1
3	35012	RING - guard, shift lever	1
4	C 19324	PIN - shift lever	1
5	C 11162	HOUSING - shift lever	1
6	C 11163	KEEPER - shift lever	1
7	C 18957	LEVER - shift	1
8	NSS	ROD ASSY - shift (order Ref. 9 thru 12 and 24)	1
9	C 11166	SPRING	2
10	211- 5	BALL - steel	2
11	C 11167	FORK - shifter	2
12	C 11168	ROD - shifter (3rd and 4th)	1
13	NSS	ROD ASSY - shift (order Ref. 9, 10, 11 and 14)	1
14	C 11170	ROD - shifter (1st - 2nd and reverse)	1
15	C 11171	AXLE - transmission	2
16	C 11178	WASHER - thrust	5
17	113- 12	SCREW - 1/4" x 2-1/2" NC hex cap.	8
18	92- 4	LOCKWASHER - 1/4"	8
19	C 19540	GEAR - ring	1
20	C 11173	PIN - drive	1
21	C 11174	BLOCK - drive	2
22	C 19546	PINION - bevel	2
23	C 19536	SHAFT AND GEAR - brake	1
24	A 11538	RING - snap	2
25	C 11177	SHAFT AND BEARING ASSY - pinion	1
26	A 27287	BEARING - pinion	1
27	C 11179	GEAR ASSEMBLY - cluster	1
28	C 11180	BUSHING - cluster gear	3
29	C 11181	STOP - shifter	1
30	C 11182	GASKET - case and cover	1
31	C 11183	GASKET - shift lever housing	1
32	C 11184	GEAR - shifting (3rd and 4th)	1
33	C 11185	GEAR - shifting (1st - 2nd and reverse)	1
34	C 19547	GEAR - bevel	2
35	C 11187	GEAR - idler	1
36	C 11188	GEAR ASSEMBLY - cluster (Includes two of Ref. 28)	1
37	C 11189	SPACER	1
38	C 11222	RING - snap	2
39	C 11190	SHAFT - input	1
40	C 11191	GEAR - spur, input shaft	1
41	C 11201	WASHER - thrust	2
42	C 11192	SEAL AND RETAINER - oil (includes ref 43)	2
43	C 11195	SEAL - oil	3
44	C 11194	PINION - output	1
45	C 11193	GEAR - output	1

C 18956 TRANSAXLE

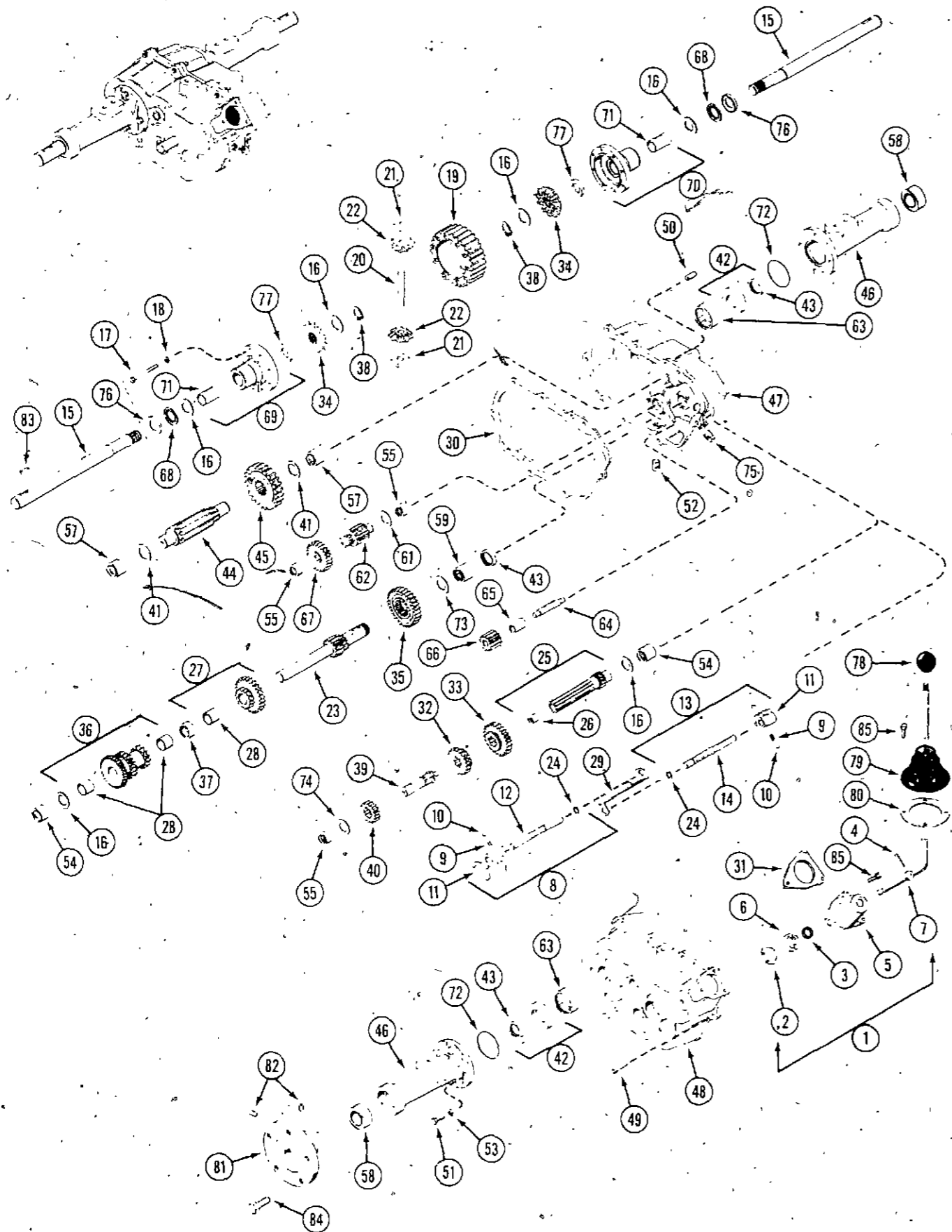

REF.	PART NO	DESCRIPTION	REQ'D
46	C 11196	HOUSING - axle	2
47	C 19538	COVER ASSY - transaxle (Includes ref. 54, 55, 57, 59 & 63)	1
48	C 19537	CASE ASSY - transaxle (Includes ref. 54, 55, 57 & 63)	1
49	83- 412	SCREW - 1/4" x 3/4" NC socket head	11
50	F 53650	PIN - dowel	2
51	83- 514	SCREW - 5/16" x 7/8" NC hex	8
52	221- 672	PLUG - drain, magnetic	1
53	92- 5	LOCKWASHER - 5/16"	8
54	C 11200	BEARING - needle	2
55	A 27999	BEARING - needle	2
56	C 11202	BEARING - ball	1
57	C 11203	BEARING - needle	2
58	C 11204	BEARING - ball	2
59	A 12652	BEARING - needle	1
60	C 11206	SEAL - oil	1
61	C 11205	WASHER - thrust	1
62	C 11207	SHAFT AND PINION	1
63	R 21491	BEARING - needle	2
64	C 11209	SHAFT - idler, reverse	1
65	C 11210	SPACER - idler, reverse	1
66	C 11211	IDLER - reverse	1
67	C 11212	GEAR - spur	1
68	F 19633	BEARING - thrust	2
69	C 19541	CARRIER ASSY - differential	1
70	C 19542	CARRIER ASSY - differential	1
71	C 11216	BUSHING - carrier assembly	2
72	C 11208	"O" RING - axle housing	2
73	C 11223	WASHER - thrust	1
74	F 15105	WASHER - thrust	1
75	221- 1843	PLUG - pipe	1
76	C 19544	RACE - thrust	2
77	C 19545	WASHER	2
78	C 10487	KNOB - shift lever	1
79	C 26189	BOOT - shift lever	1
80	C 19450	RING - boot mounting (early production)	1
81	C 26462	HUB - rear wheel	2
82	83- 68	SETSCREW - 3/8" x 1/2" NC soc.	4
83	126- 128	KEY - Woodruff #18	2
84	C 10314	BOLT - mounting, rear wheel	10
85	187- 1073	SCREW - 1/4" hex washer head - self tapping (early production)	4

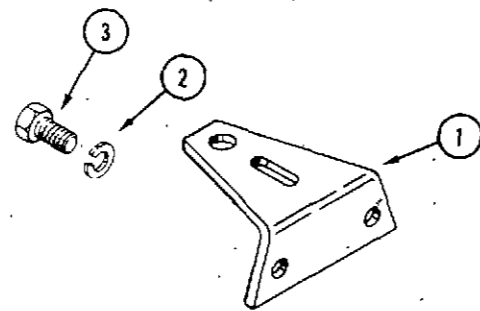
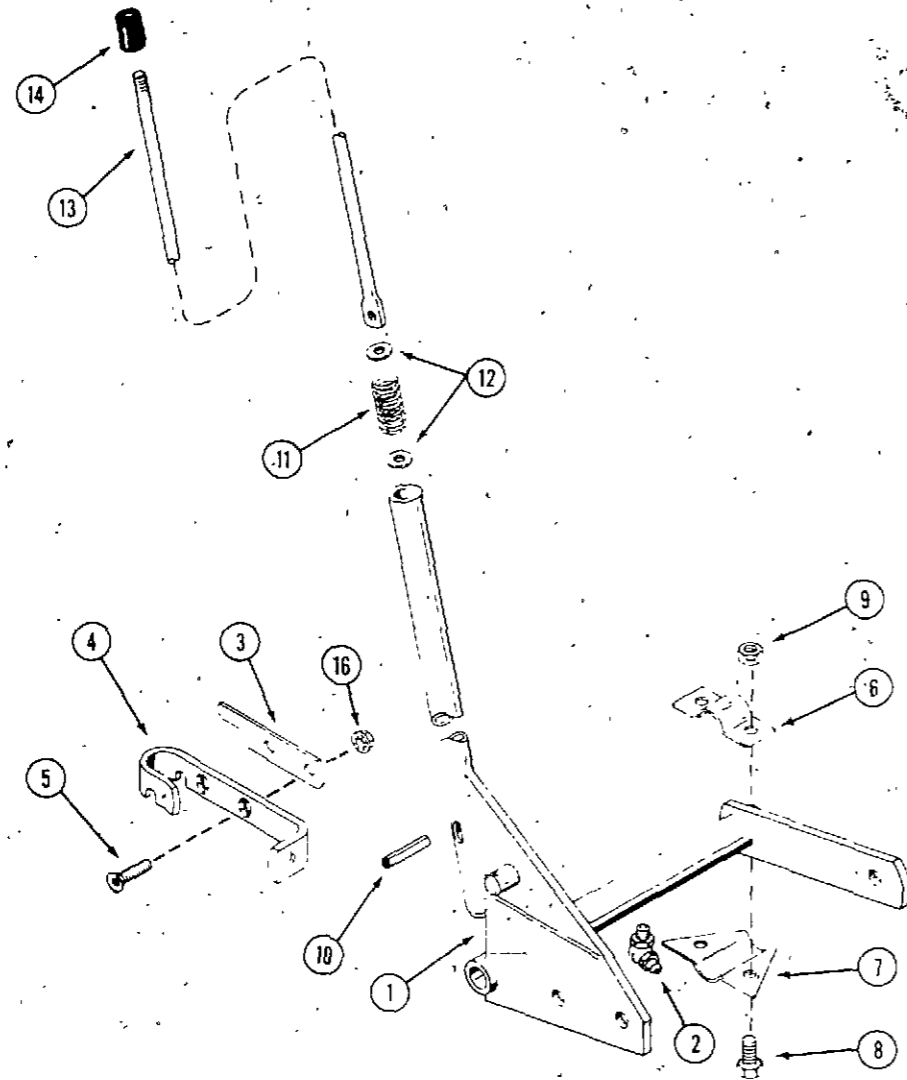

IMPLEMENT LIFT

REF.	PART NO	DESCRIPTION	REQ'D
1	C 18809	LEVER ASSEMBLY - implement lift	1
2	219- 404	FITTING - lube 45°	1
3	C 17281	SPACER - latch	5
4	C 18811	LIFT - latch	1
5	164- 42	SCREW - 5/16" x 1-1/4" flat head socket	2
6	C 17249	BRACKET - mounting top	1
7	C 17250	BRACKET - mounting bottom	1
8	113- 207	BOLT - 3/8" x 1" NC hex	4
9	131- 1181	NUT - lock 3/8"	4
10	138- 2054	PIN - spiral 5/16" x 1-3/4"	1
11	C 15564	SPRING - lift lever	1
12	195- 521	WASHER - 3/8" x 11/16" OD	2
13	C 17067	ROD - lift lever, push	1
14	C 14525	BUTTON - thumb	1
15	138- 2054	PIN - spiral 5/16" x 1-3/4"	1
16	131- 911	NUT - lock 5/16" - 18 flanged	2

DRAWBAR AND TOW HITCH

1	C 13360	DRAWBAR	1
2	192- 23	LOCKWASHER - 1/2" zinc plated	2
3	113- 424	BOLT - 1/2" x 1" NC hex zinc plated	2

STARTER

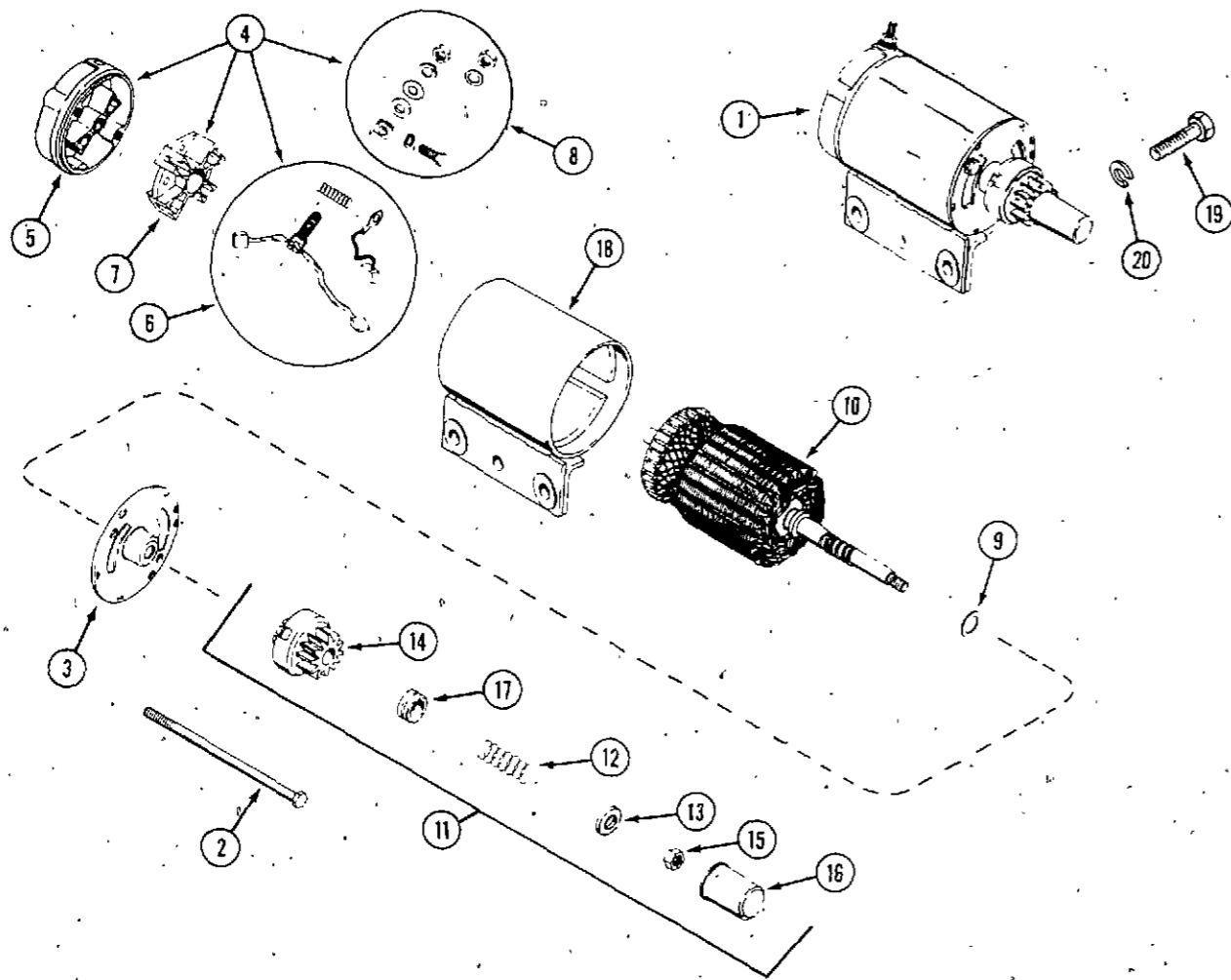

REF.	PART NO.	DESCRIPTION	REQ'D
1	C 24889	STARTER ASSEMBLY	1
2	V 34381	BOLT - thru	2
3	V 34392	CAP - end	1
4	V 34384	KIT - commutator cap	1
5	NSS	CAP - commutator	1
6	V 34383	KIT - brush and spring	1
7	NSS	KIT - brush holder	1
8	NSS	KIT - hardware	1
9	V 34382	WASHER - armature thrust	1
10	C 24890	ARMATURE	1
11	C 24891	KIT - drive	1
12	V 34386	SPRING - anti-drift	1
13	V 34387	SPACER - gear stop	1
14	NSS	GEAR - drive	1
15	V 34388	NUT - gear stop	1
16	C 24892	COVER - dust	1
17	V 34391	SPACER - dust cover	1
18	NSS	BODY - starter	1
19	C 24886	BOLT - shoulder 3/8" - 20 x 1-5/16"	2
20	192- 21	LOCKWASHER - 3/8"	2
	321- 1834	DECAL - alternator electrical system	1
	C 24880	DECAL - "DO NOT STRIKE"	1



ELECTRICAL SYSTEM

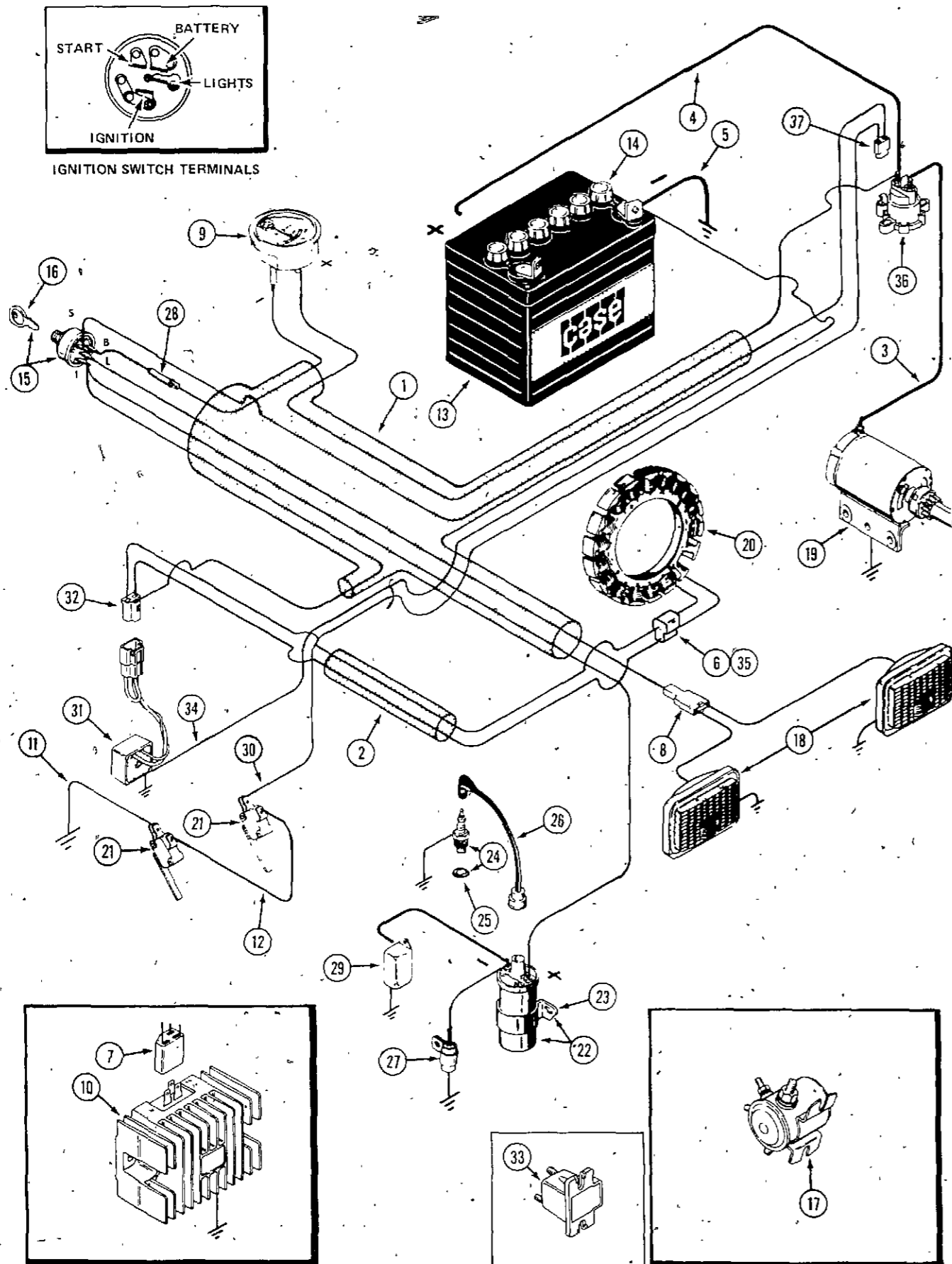

REF.	PART NO.	DESCRIPTION	REQ'D
1	C 24898	HARNESS - wire (use before S/N 9778952)	1
1	C 25564	HARNESS - wire (use S/N 9778952 to 14053477)	1
1	C 27527	HARNESS - wire (use S/N 14053477 and after)	1
2	C 24815	HARNESS - wire	1
3	C 24816	CABLE - solenoid to starter (black) (use before S/N 14053477)	1
3	C 27528	CABLE - solenoid to starter (black) (use S/N 14053477 and after)	1
4	C 14565	CABLE - solenoid to battery positive (red) (use before S/N 14053477)	1
4	C 27521	CABLE - solenoid to battery positive (red) (use S/N 14053477 and after)	1
5	C 24814	CABLE - battery negative to ground (black)	1
6	C 24813	CONNECTOR - to stator (included in C24815 harness)	1
7	C 19378	CONNECTOR - rectifier (use before S/N 9778826)	1
8	C 14537	CONNECTOR - lights	1
9	C 18389	AMMETER - 30 amps, 12v	1
10	NSS*	RECTIFIER - voltage, 12v (use before S/N 9778826)	1
11	C 24825	WIRE - switch to ground (black)	1
12	C 24817	WIRE - switch to switch (black)	1
13	C 18197	BATTERY - 12v	1
14	C 18113	CAP - battery	6
15	C 23010	SWITCH ASSEMBLY - ignition (includes key and lock washer)	1
16	A 24509	KEY - ignition	1
17	C 14553	SOLENOID - start 12v (use before S/N 9778952)	1
18	C 22571	HEADLAMP ASSEMBLY - 12v (repairs page 49)	2
19	C 24889	STARTER - bendix drive (repairs page 45)	1
20	V 34427	STATOR	1
21	C 24800	SWITCH - neutral start	2
22	KO 231281	COIL - ignition, 12v (includes bracket)	1
23	V 34435	BRACKET - coil mounting	1
24	C 24301	SPARK PLUG - (includes gasket)	1
25	A 27251	GASKET - spark plug	1
26	V 34433	CABLE - high tension	1
27	KO 230722	CONDENSER	1
28	223- 20	FUSE - 20 amp (included in harness)	1
29	NSS	BREAKER CONTACT ASSEMBLY - ignition (repairs page 49)	1
30	C 24896	WIRE - solenoid to micro switch (use before S/N 9778952)	1
30	C 25563	WIRE - solenoid to micro switch (use S/N 9778952 to 14053477)	1
30	C 27530	WIRE - solenoid to micro switch (use S/N 14053477 and after)	1
31	C 25485	RECTIFIER - voltage, 12v (use S/N 9778826 and after)	1
32	C 25486	CONNECTOR - rectifier (use S/N 9778826 and after)	1
33	C 26525	SOLENOID - start, 12v (use S/N 9778952 to 14053477)	1
34	C 26670	WIRE - rectifier ground to battery negative	1
35	C 25338	CONNECTOR - from stator	1
36	C 27523	SOLENOID - start, 12v (use S/N 14053477 and after)	1
37	C 27549	CONNECTOR - solenoid (use S/N 14053477 and after)	1
	C 25244	WIRE - blower housing to engine mounting bolt	1

\* use C25486, C26670 and C27509

CASE MODEL 210 COMPACT TRACTOR

ELECTRICAL SYSTEM HARDWARE

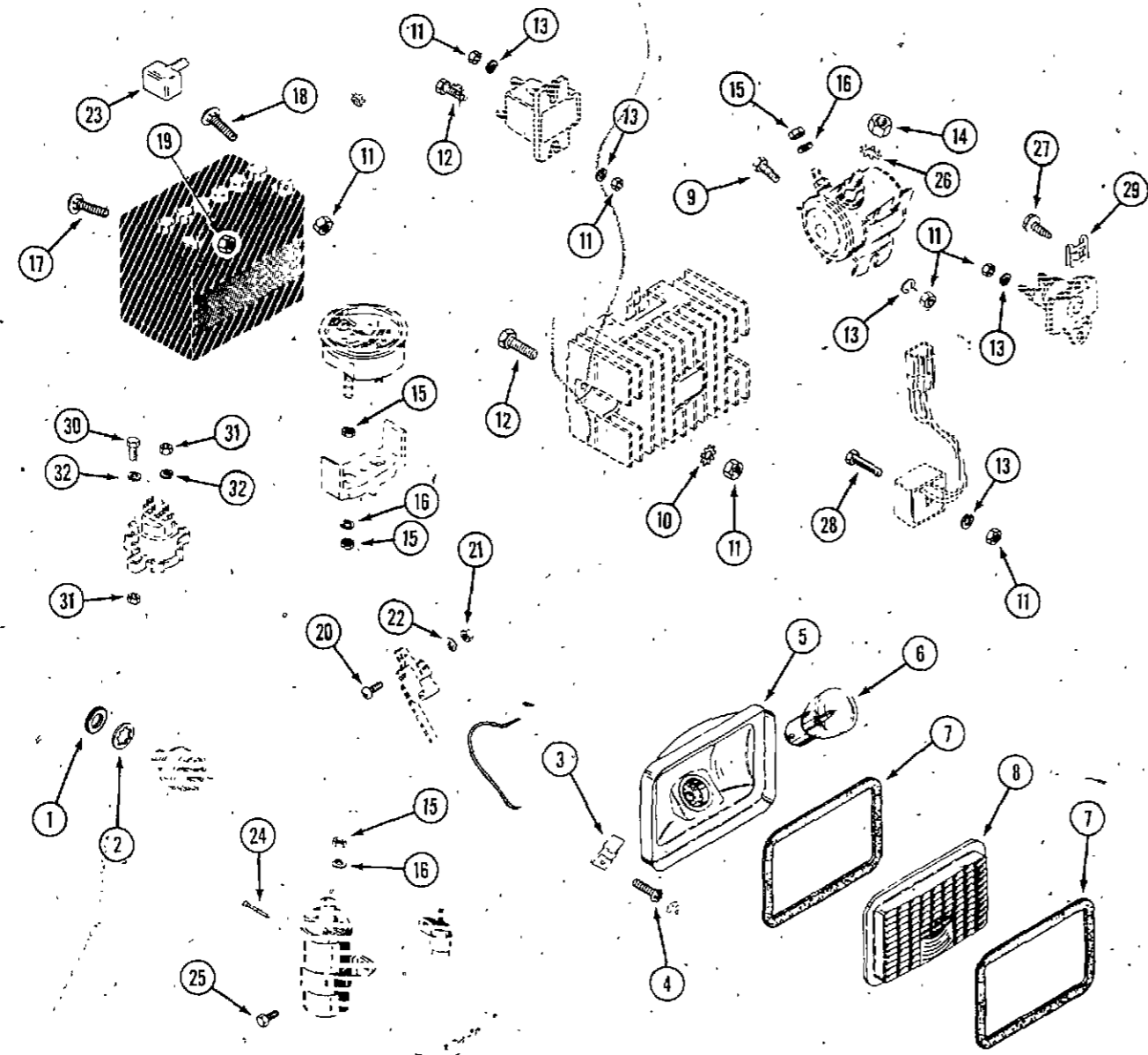

REF.	PART NO.	DESCRIPTION	REQ'D.
1	C 23330	NUT - switch mounting	1
2	C 23012	LOCKWASHER - internal tooth	1
3	131- 629	NUT - speed type "U"	4
4	187- 1047	SCREW - #8 x 1/2" self tapping, rd. head Phillips	4
	187- 1334	HEADLAMP ASSEMBLY	2
5	NSS	RECEPTACLE - headlamp (order C22571)	1
6	A 41264	BULB - headlamp	1
7	C 14304	GASKET - headlamp	2
8	C 22573	LENS - headlamp	1
9	113- 1	BOLT - 1/4" - 20 x 1/2" hex	2
10	193- 57	LOCKWASHER - 1/4" external tooth	2
11	129- 101	NUT - 1/4" - 20 hex	2
12	113- 3	BOLT - 1/4" - 20 x 3/4" hex	2
13	192- 19	LOCKWASHER - 1/4"	3
14	129- 162	NUT - 5/16" NF hex	2
15	129- 27	NUT - #10 N.F. hex	2
16	193- 99	LOCKWASHER - #10	2
17	111- 202	BOLT - 5/16" x 3/4" N.C. rd. head sq. neck	1
18	111- 108	BOLT - 1/4" x 3/4" N.C. rd. head sq. neck	1
19	129- 102	NUT - 5/16" NC hex	1
20	182- 10	SCREW - #4 - 40 x 7/8" N.C. Pan head	2
21	129- 13	NUT - #4 - 40 hex	2
22	192- 13	LOCKWASHER - #4	2
23	C 24069	COVER - terminal	1
24	187- 1844	SCREW - #10 x 1-1/2" N.F. self tap	1
25	22- 58	BOLT - 5/16 x 1/2 N.C. hex, self tap	2
26	193- 29	LOCKWASHER	2
27	187- 1908	SCREW - self tapping	2
28	113- 17	BOLT - 1/4" - 20 x 1-1/4" hex	1
29	C 10836	NUT - speed type "U"	2
30	182- 147	BOLT - # 10 - 32 x 3/4"	2
31	129- 37	NUT - # 10 - 32 hex	4
32	192- 18	LOCK WASHER - # 10	4
V	34829	CLIP - statör wires	1
C	19521	RETAINER - wire, head lamp	1

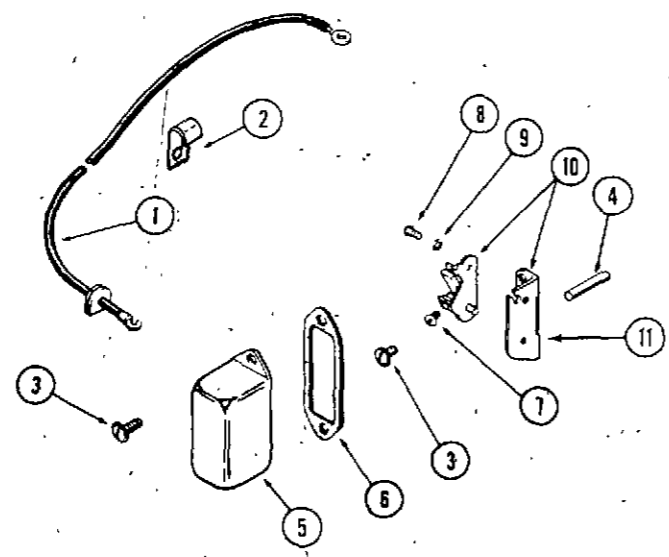

REF.	PART NO.	DESCRIPTION	REQ'D.
1	NSS	LEAD - breaker contact (order from local supplier)	1
2	KO 275182	CLIP - wire	1
3	V 34421	SCREW - #10 x 3/8" fillister head, sems	4
4	C 27440	ROD - breaker contact push	1
5	V 35060	COVER - breaker contact	1
6	C 26518	GASKET - cover	1
7	187- 408	SCREW - #6 x 3/8" Self-Tapping	1
8	173- 224	SCREW - #8 x 1/4" NC round head	1
9	193- 90	LOCKWASHER - #8 internal tooth	1
10	C 24135	POINT SET - breaker contact	1
11	NSS	BRACKET - breaker contact	1

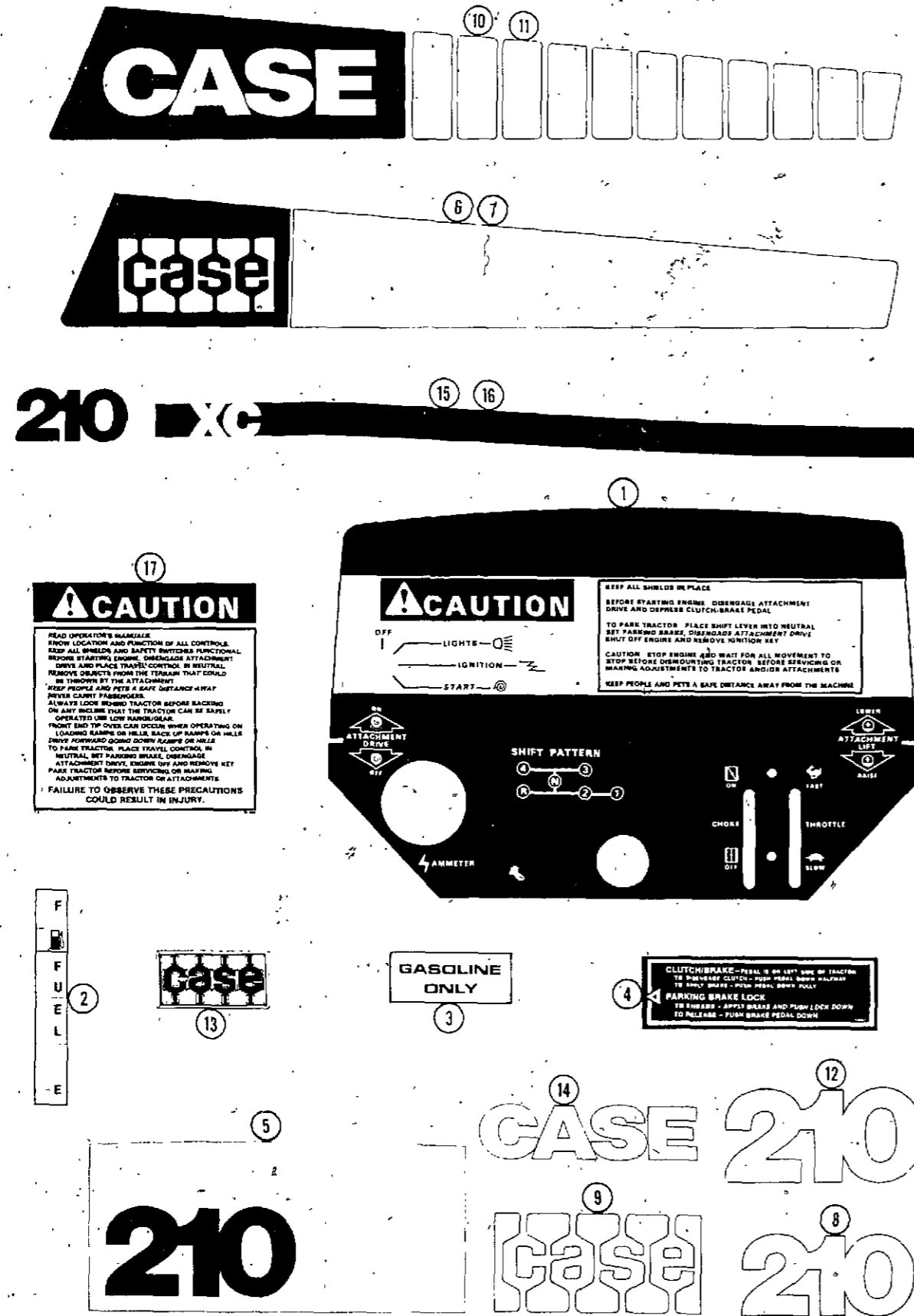

**DECALS**  
**(English)**

REF.	PART NO.	DESCRIPTION	REQ'D
1	NSS	DECAL - instrument panel (use C26878 and 321-6659)	1
2	C 26699	DECAL - fuel gauge (used S/N 14018227 and after)	1
3	321- 18	DECAL - gasoline	1
4	C 27480	DECAL - clutch, brake	1
5	321- 4161	DECAL - hood top (used prior to S/N 9748015)	1
6	321- 4157	DECAL - hood, R.H. (shown) (used prior to S/N 9748015)	1
7	321- 4158	DECAL - hood, L.H. (used prior to S/N 9748015)	1
8	321- 4149	DECAL - fender, "210" (used prior to S/N 9748015)	1
9	321- 2677	DECAL - fender, "CASE" (used prior to S/N 9748015)	1
10	321- 5100	DECAL - hood, R.H. (shown) (used S/N 9748015 to 14033980)	1
11	321- 5101	DECAL - hood, L.H. (used S/N 9748015 to 14033980)	1
12	321- 5102	DECAL - "210" hood top (used S/N 9748015 to 14033980)	1
13	321- 5040	MEDALLION - "CASE" (used S/N 9748015 and after)	1
14	321- 5097	DECAL - "CASE" seat back (used S/N 9748015 and after)	1
		DECAL - "CASE" seat back (used S/N 9748015 to 14033980)	1
15	C 27180	DECAL - hood L.H. (use S/N 14033980 and after)	1
16	C 27188	DECAL - hood R.H. (use S/N 14033980 and after)	1
17	321- 6659	DECAL - "Caution"	1

**(French and English)**

1	321- 4752	DECAL - instrument panel	1
2	NSS	DECAL - parking brake (use 321-6324)	1
3	321- 4728	DECAL - gasoline	1
4	NSS	DECAL - clutch, brake (use 321-6324)	1

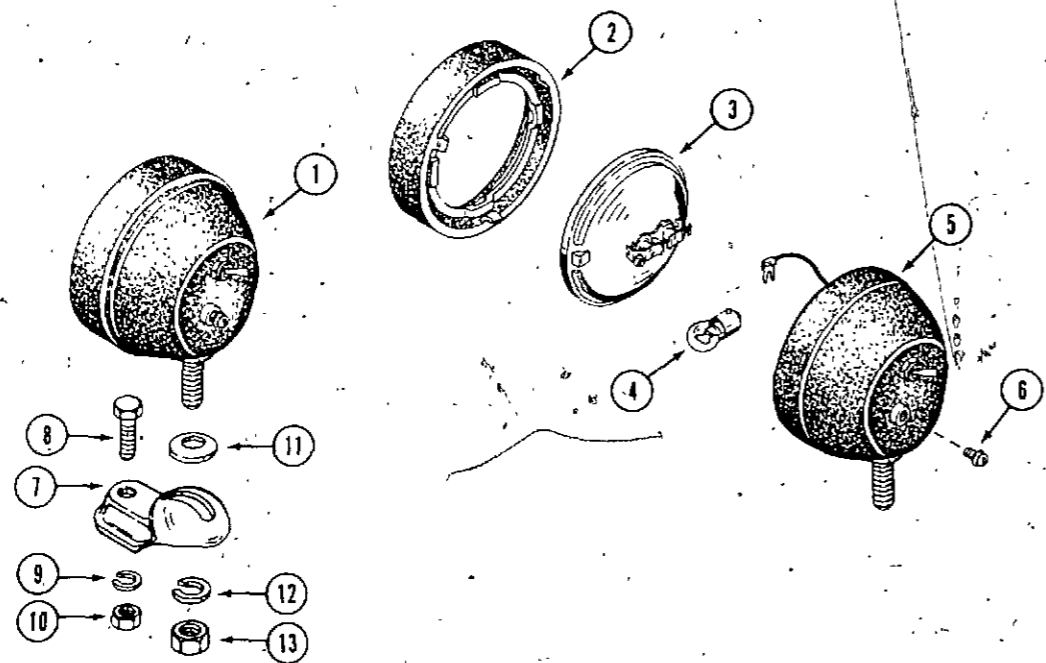

D70115 FLOOD AND TAIL LAMP (OPTIONAL)

REF.	PART NO.	DESCRIPTION	REQ'D
1	D 70115	LIGHT ASSEMBLY - flood and tail	1
2	A 25213	RETAINER - sealed beam	1
3	A 40855	LAMP - sealed beam #4409X	1
4	33686	BULB - tail #1141	1
5	NSS	SHELL - light (order D70115 light assembly)	1
6	193- 543	SCREW AND LOCKWASHER - #8 - 32 x 3/8" N.C.	1
7	A 34046	BRACKET - mounting	1
8	113- 209	BOLT - 3/8" x 1-1/2" N.C. hex	1
9	192- 21	LOCKWASHER - 3/8"	1
10	129- 103	NUT - 3/8" N.C. hex	1
11	10923	WASHER - bearing	1
12	192- 23	LOCKWASHER - 1/2"	1
13	129- 105	NUT - 1/2" N.C. hex	1

K8 WHEEL WEIGHTS

1	NSS	WEIGHT - wheel, 55 lb. (order as machinery item)	2
2	131- 1182	NUT - 1/2" NC hex	8
3	195- 533	WASHER - 1/2"	8
4	111- 521	BOLT - 1/2" x 7" rd. hd. sq. neck	8

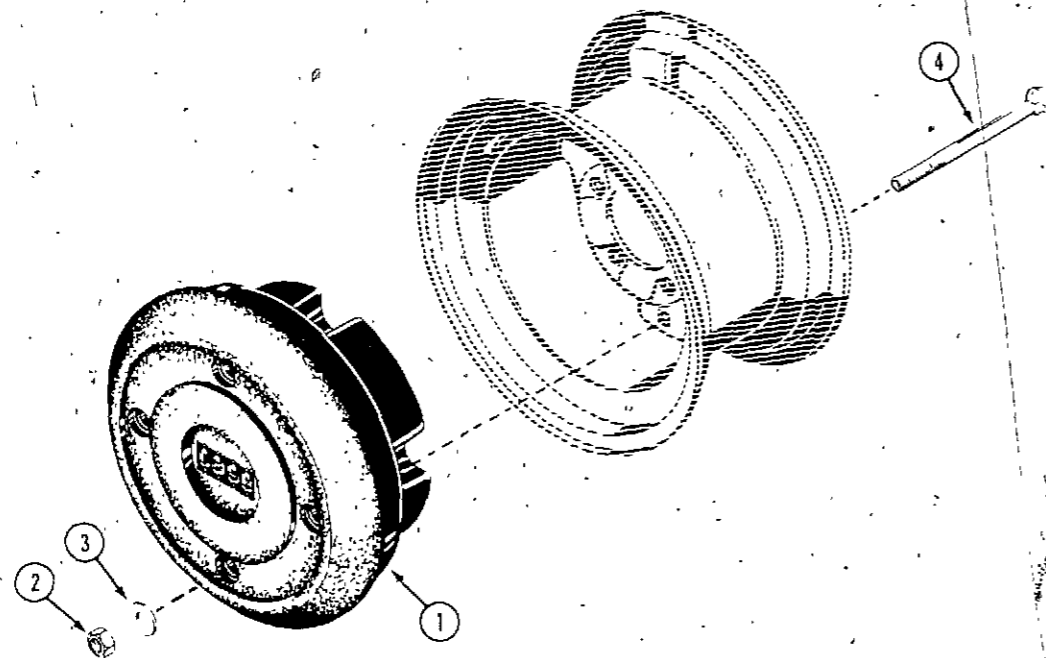

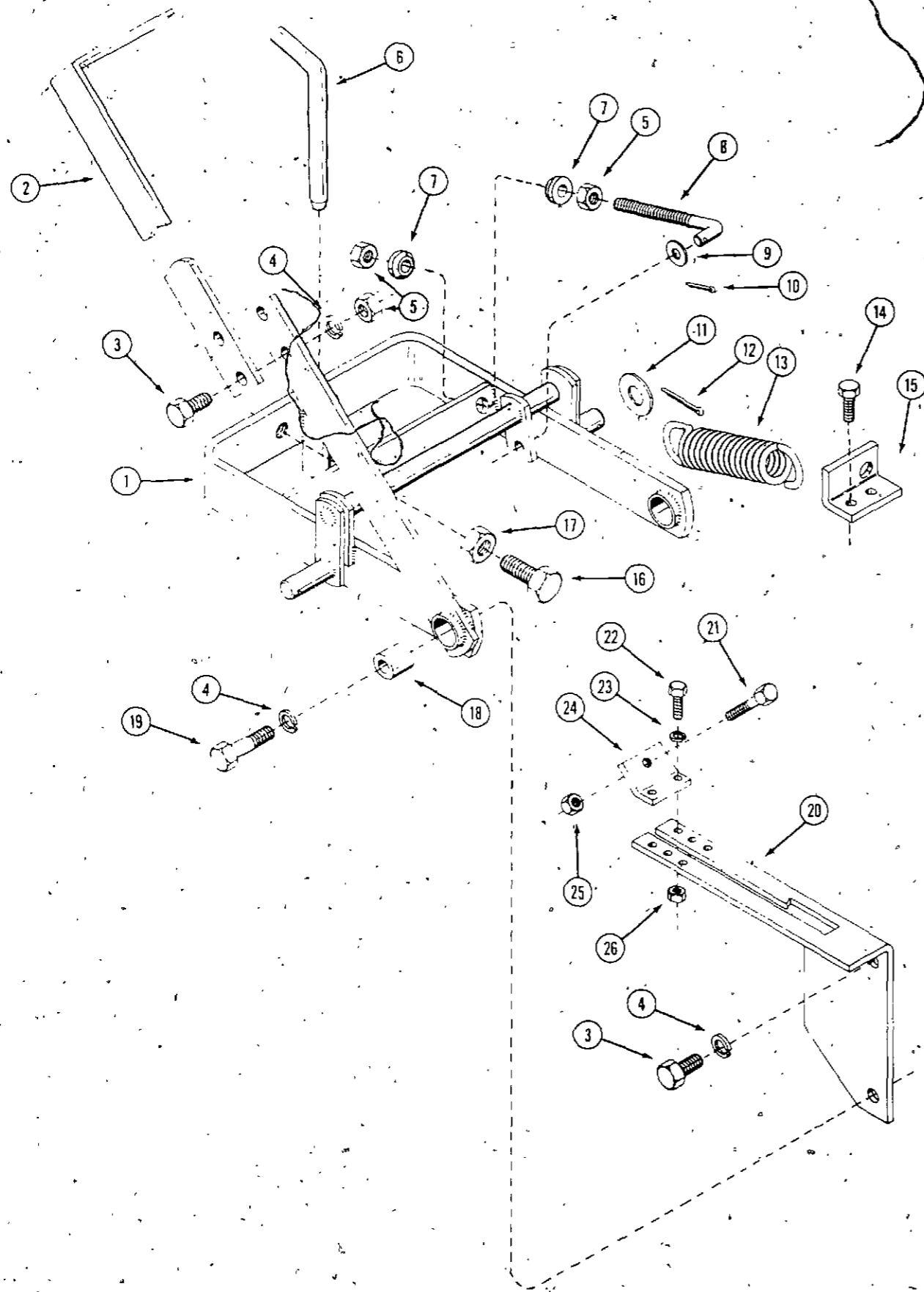

J 21 SLEEVE HITCH

REF.	PART NO.	DESCRIPTION	REQ'D
1	C 19514	HITCH ASSEMBLY	1
2	C 19497	HANDLE - lift	1
3	113- 424	BOLT - 1/2" x 1" NC hex	3
4	192- 23	LOCKWASHER - 1/2"	5
5	129- 105	NUT - 1/2" NC hex	4
6	C 14568	PIN - drawbar	1
7	C 16097	WASHER - domed	2
8	C 19502	J-BOLT - adjusting	1
9	195- 529	WASHER - 7/16" flat	1
10	132- 48	PIN - cotter 1/8" x 1"	1
11	195- 545	WASHER - 3/4" flat	2
12	132- 306	PIN - cotter 3/16" x 1-3/4"	2
13	C 19501	SPRING - assist	2
14	113- 207	BOLT - 3/8" x 1" NC (Replaces transaxle mounting bolts) when attaching spring brackets	4
15	C 19516	BRACKET - spring attaching L.H. shown	1
16	C 19517	BRACKET - spring attaching R.H.	1
17	113- 607	BOLT - 5/8" x 1-1/2" NC hex	2
18	129- 107	NUT - 5/8" NC hex	2
19	C 25580	SLEEVE - pivot	2
20	113- 421	BOLT - 1/2" x 2" NC hex	2
21	C 19496	LATCH - hitch	1
22	113- 257	BOLT - 3/8" x 2-1/2" NC hex	1
23	113- 103	BOLT - 5/16" x 1" NC hex	2
24	192- 20	LOCKWASHER - 5/16"	2
25	C 19498	BRACKET - lift stop	1
26	129- 103	NUT - 3/8" hex	1
	129- 102	NUT - 5/16" hex	2

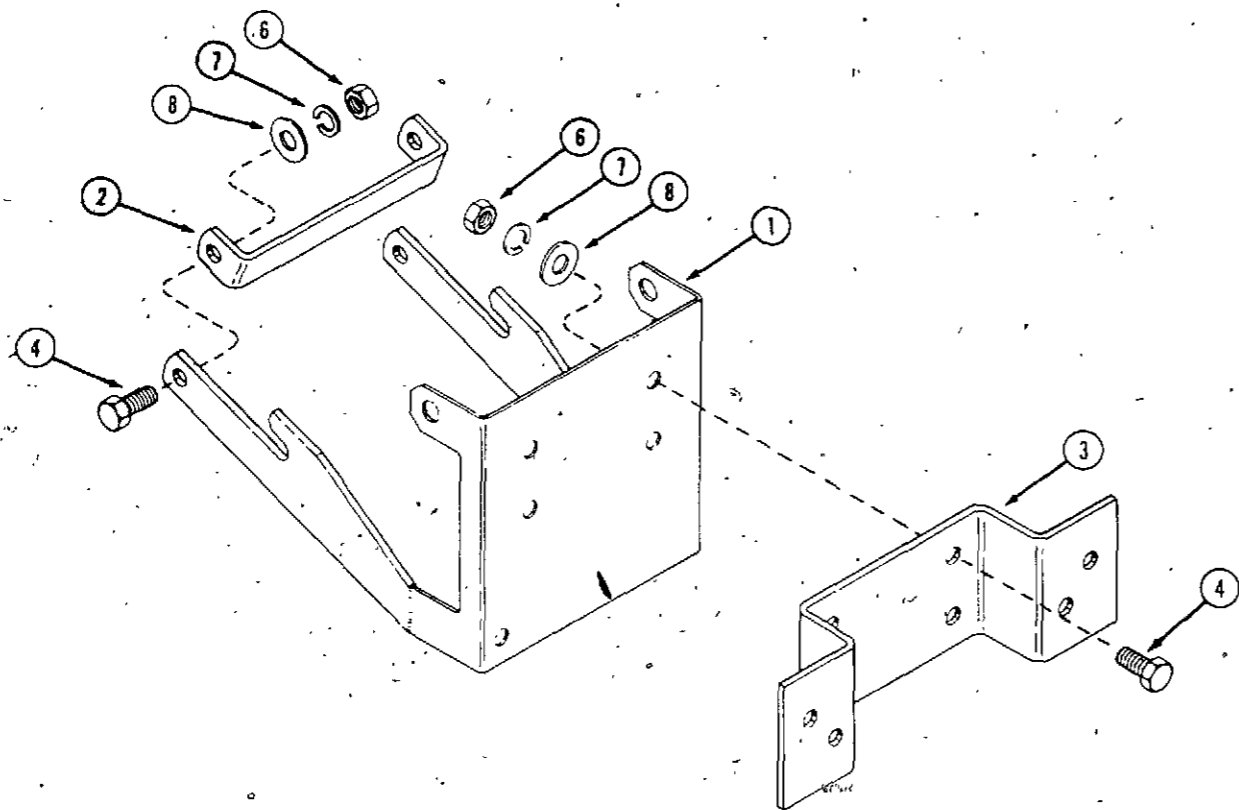

MODEL K18 FRONT END WEIGHT BRACKETS

REF.	PART NO.	DESCRIPTION	REQ'D
1	C 16581	BRACKET - mounting	1
2	C 17161	BRACE - rear	1
3	C 17162	BRACKET - weight mounting	1
4	113- 417	BOLT - 1/2" x 1-1/4" NC hex, zinc plated	6
5	113- 443	BOLT - 1/2" x 6-1/2" NC hex	2
6	129- 105	NUT - 1/2" NC hex, zinc plated	6
7	192- 23	LOCKWASHER - 1/2"	6
8	195- 533	WASHER - 1/2" zinc plated	6

MODEL H13 WEIGHT BOX

1	C 17859	FRAME - weight box	1
2	C 17863	BOX - weight	1
3	C 17860	SUPPORT - weight box	1
4	C 17636	PLATE - hitch	1
5	111- 371	BOLT - 3/8" x 1" round head, square neck	3
6	113- 207	BOLT - 3/8" x 1" NC hex	4
7	129- 103	NUT - 3/8" NC hex	7
8	192- 21	LOCKWASHER - 3/8"	7
9	195- 525	WASHER - 3/8"	7

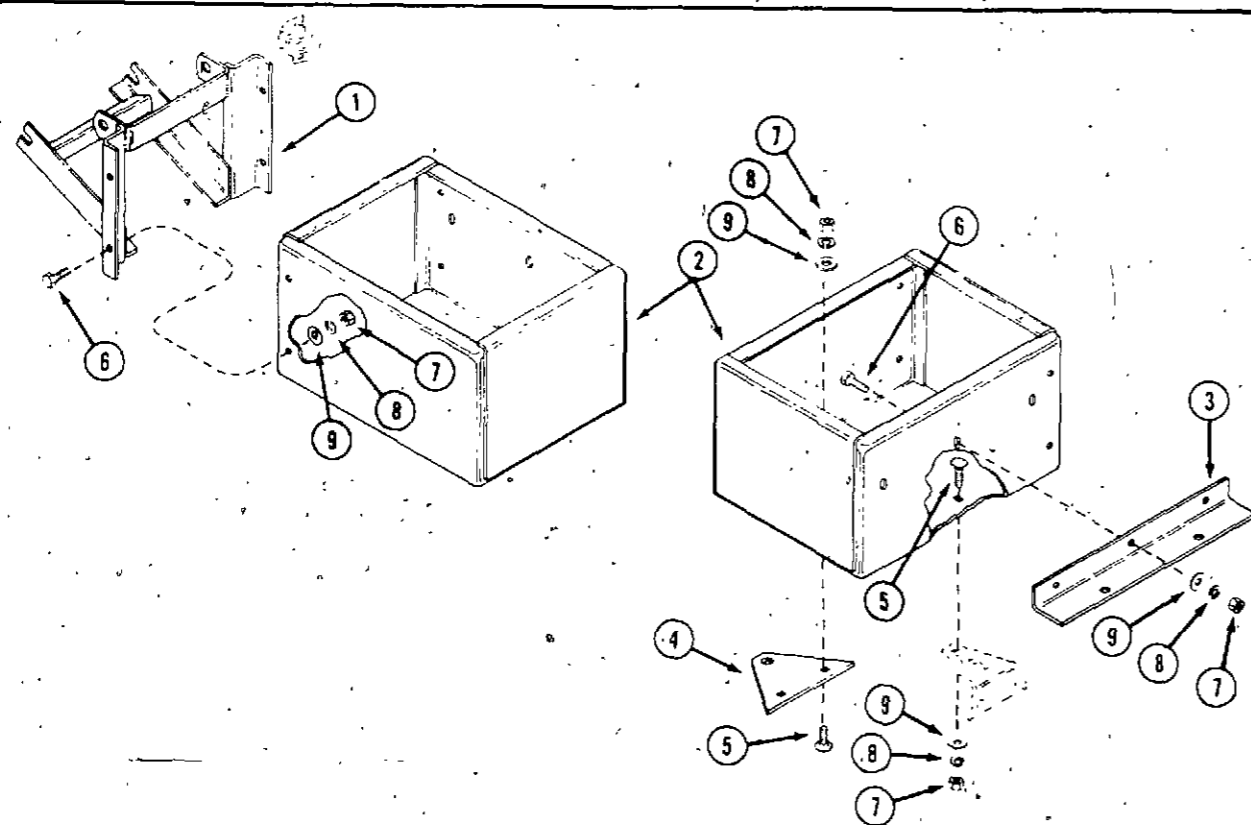

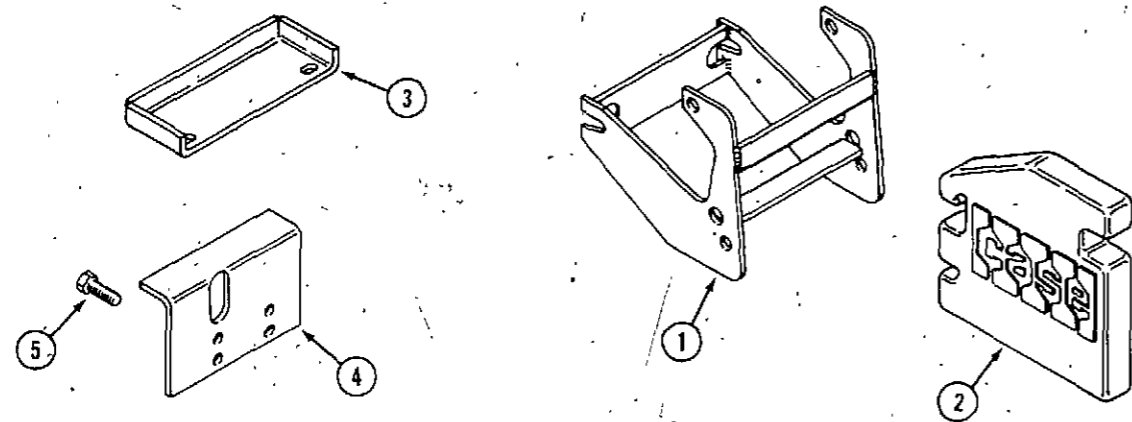

L11 WEIGHT BRACKETS

REF.	PART NO.	DESCRIPTION	REQ'D
1	C 25572	BRACKET - mounting, front	1
2	C 25574	WEIGHT - 40 lb. (18 kg)	1
3	C 25791	BRACKET - mounting, rear, upper	1
4	C 25792	BRACKET - mounting, rear, lower	1
5	113- 417	BOLT - 1/2" - 18 x 1-1/4" hex.	2

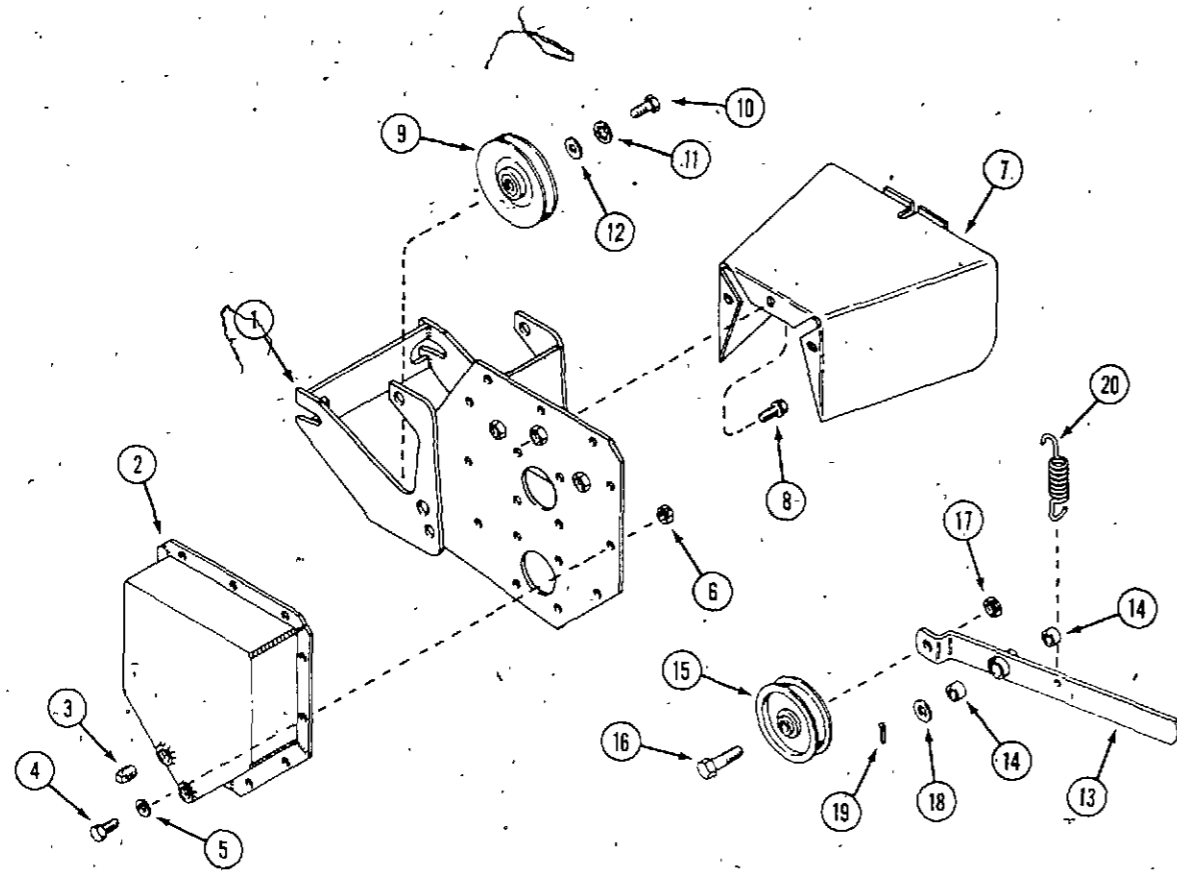

L29 PTO MOUNTING FRAME, SHIELD, IDLERS AND GEAR COVER

REF.	PART NO.	DESCRIPTION	REQ'D
1	C 25800	FRAME - mounting	1
2	C 25815	COVER - gear	1
3	221- 4	PLUG - oil 1/2"	1
3	221- 1843	PLUG - oil 3/8"	2
4	113- 3	BOLT - 1/4" - 20 x 3/4" hex	9
5	195- 521	WASHER - 5/16"	9
6	131- 1180	NUT - 1/4" - 20 hex	9
7	C 25817	SHIELD - PTO	1
8	121- 106	BOLT - 5/16" - 18 x 1/2", special	3
9	C 25370	PULLEY - "V" groove	1
10	113- 206	BOLT - 3/8" - 16 x 3/4"	1
11	193- 68	LOCK WASHER - special	1
12	195- 103	WASHER - 3/8"	1
13	C 25822	ARM - idler	1
14	R 30880	BUSHING - sleeve	2
15	C 26090	PULLEY - flat idler	1
16	113- 412	BOLT - 1/2" - 13 x 1-3/4" hex	1
17	131- 165	NUT - 1/2" lock, hex	1
18	195- 541	WASHER - 5/8"	1
19	132- 318	PIN - cotter 5/32" x 1"	1
20	C 16870	SPRING - tension	1

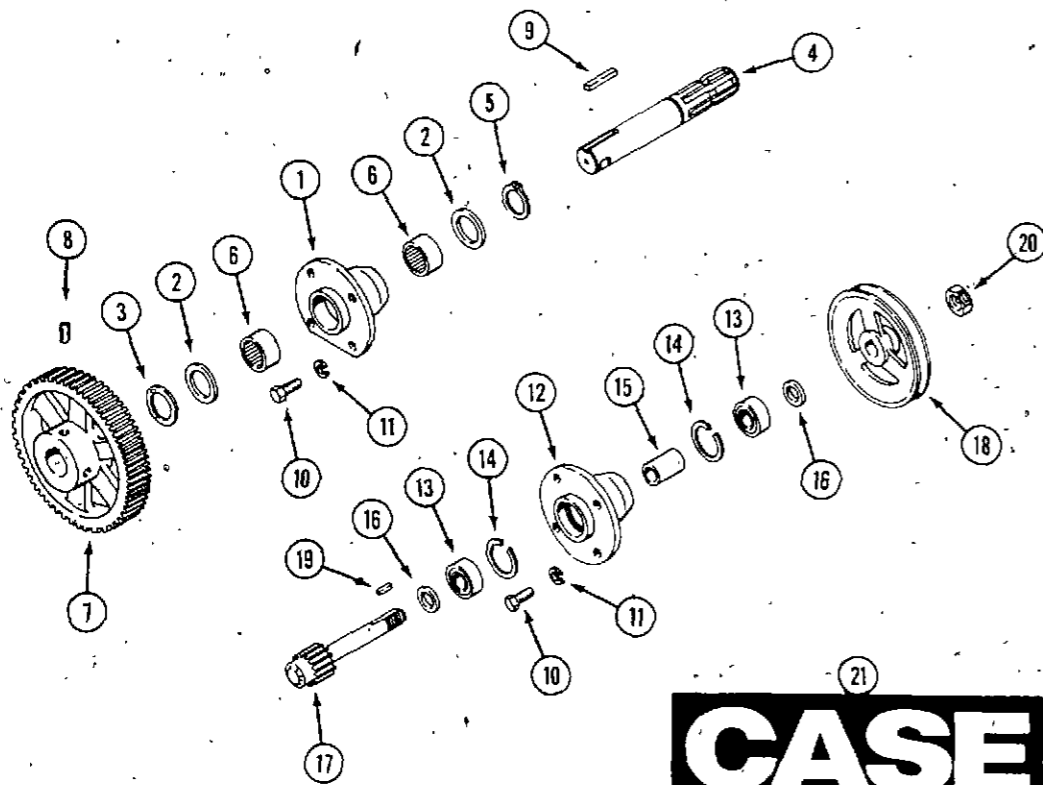

L29 SPINDLES, DECALS AND BELT

1	C 25806	HOUSING - PTO shaft	1
2	C 25807	WASHER - thrust	2
3	195- 2131	WASHER - spacer	1
4	C 25808	SHAFT - spline	1
5	A 7409	RING - retainer	1
6	C 25828	BEARING - roller	2
7	C 25814	GEAR - driven	1
8	83- 68	SET SCREW - 3/8"	2
9	B 18323	KEY - 5/16" x 2"	1
10	113- 206	BOLT - 3/8" - 16 x 3/4" hex	8
11	192- 21	LOCK WASHER - 3/8"	8
12	C 17666	HOUSING - spindle	1
13	A 70280	BEARING	2
14	C 16516	RING - retaining	2
15	C 10810	SPACER - bearing	1
16	C 25541	WASHER - spacer	2
17	C 25810	SPINDLE - input	1
18	C 25813	PULLEY - spindle	1
19	H 233346	KEY - 3/16" square x 7/8"	1
20	131- 1331	NUT - 3/4" - 16 lock, hex	1
21	321- 6379	DECAL - "Case"	1
22	321- 3710	DECAL - "Warning" (English)	1
22	321- 6647	DECAL - "Warning" (French)	1
23	321- 4745	DECAL - drive belt (French)	1
23	C 17462	DECAL - drive belt (English)	1
	C 23539	BELT - drive (444, 446, 448)	1
	C 23538	BELT - drive (210, 220, 222, 224)	1

**CASE**

**WARNING**  
 ROTATING MACHINE PARTS  
 STAY CLEAR. KEEP  
 SHIELDS INSTALLED TO HELP  
 PROTECT FROM CLOTHING  
 ENTANGLEMENT AND INJURY

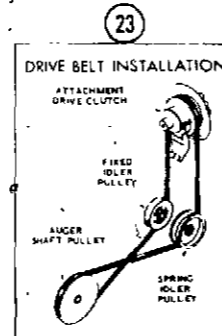







## NUMERICAL INDEX

PART NO.	PAGE NO.	REF. NO.	PART NO.	PAGE NO.	REF. NO.	PART NO.	PAGE NO.	REF. NO.
187-	1844	51	24	195-	525	33	22	
187-	1908	51	27	195-	525	39	20	
187-	1910	29	11	195-	525	59	9	
192-	13	51	22	195-	529	57	9	
192-	13	51	22	195-	533	21	23	
192-	18	19	6	195-	533	55	3	
192-	19	23	26	195-	533	59	8	
192-	19	51	13	195-	541	31	29	
192-	20	5	5	195-	541	63	18	
192-	20	15	6	195-	545	57	11	
192-	20	25	11	195-	2021	27	10	
192-	20	27	5	195-	2021	31	9	
192-	20	31	10	195-	2029	31	24	
192-	20	35	4	195-	2069	21	21	
192-	20	57	23	195-	2069	31	15	
192-	21	19	7	195-	2069	33	15	
192-	21	23	23	195-	2131	63	3	
192-	21	25	13	205-	27	11	30	
192-	21	31	14	211-	5	41	10	
192-	21	33	6	214-	272	5	11	
192-	21	37	6	214-	274	15	4	
192-	21	47	20	217-	292	15	21	
192-	21	55	9	219-	17	29	20	
192-	21	59	8	219-	403	29	4	
192-	21	63	11	219-	404	29	6	
192-	23	27	5	219-	404	31	19	
192-	23	29	14	219-	404	45	2	
192-	23	45	2	221-	4	63	3	
192-	23	55	12	221-	43	52		
192-	23	57	4	221-	1412	11	45	
192-	23	59	7	221-	1843	43	75	
192-	404	5	17	221-	1843	63	3	
193-	6	5	9	223-	20	49	28	
193-	28	15	10	321-	18	53	3	
193-	29	51	26	321-	1834	47		
193-	56	19	8	321-	2677	53	9	
193-	57	25	27	321-	3588	53	1	
193-	57	51	10	321-	3710	63	22	
193-	68	63	11	321-	4149	53	8	
193-	76	23	5	321-	4157	53	6	
193-	90	51	5	321-	4158	53	7	
193-	99	11	24	321-	4161	53	5	
193-	99	51	16	321-	4728	53	3	
193-	543	55	6	321-	4745	63	23	
195-	103	37	5	321-	4752	53	1	
195-	103	63	12	321-	5040	53	13	
195-	104	21	17	321-	5097	53	14	
195-	104	25	12	321-	5100	53	10	
195-	104	33	9	321-	5101	53	11	
195-	104	33	18	321-	5102	53	12	
195-	104	33	26	321-	6379	63	21	
195-	104	39	5	321-	6647	63	22	
195-	137	21	18	353-	406	25	24	
195-	137	31	27	353-	442	21	13	
195-	518	19	10	353-	462	21	4	
195-	518	23	27					
195-	521	45	12					
195-	521	63	5					

**INGERSOLL**  
Ingersoll Equipment Co., Inc.