

**CASE MODEL 210  
COMPACT TRACTOR  
PRIOR TO S/N 9686282  
Parts Catalog No. A1258**

Print Shop 2500 1-76

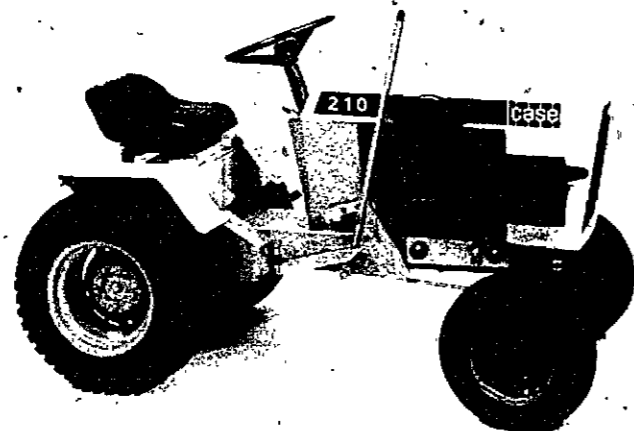

**ALPHABETICAL INDEX**

**ENGINE SECTION**

	PAGE	GRID		PAGE	GRID
Air Cleaner .....	5	A6	Filter, Breather .....	7	A8
Battery .....	49	D8	Flywheel .....	11	A12
Belt, Starter-Generator .....	15	B2	Fuel Pump .....	15-17	B2-B4
Breather, Crankcase .....	7	A8	Fuel Strainer .....	15	B2
Camshaft .....	7	A8	Fuel System .....	15	B2
Carburetor .....	15-17	B2-B4	Gasket Kits .....	13	A14
Connecting Rod .....	9	A10	Governor .....	11	A12
Crankshaft .....	9	A10	Muffler .....	5	A6
Cylinder Block .....	11	A12	Oil Pan .....	11	A12
Cylinder Head .....	11	A12	Piston .....	9	A10
Electrical System .....	49-53	D8-D12	Pulley, Clutch .....	23	B10
Engine Block & Attaching Parts .....	11	A12	Spark Plug .....	49	D8
Engine Mounts .....	19	B6	Starter-Generator .....	45-47	D4-D6
Exhaust System .....	5	A6	Tank, Fuel .....	15	B2
			Throttle Linkage .....	19	B6
			Valves .....	7	A8

**BASIC TRACTOR SECTION**

	PAGE	GRID		PAGE	GRID
Axle, Front .....	29	C2	Model J21 Sleeve Hitch .....	55	D14
Axle, Rear .....	39-41	C12-C14	Model H13 Weight Box .....	59	E4
Baffles & Shrouds .....	15	B2	Model H18 Counterweight Brackets .....	59	E4
Brakes .....	37	C10	Pulleys, Belts and Idlers .....	33-35	C6-C8
Decals .....	53	D12	Pulley Clutch .....	21-23	B8-B10
Electrical System .....	49-53	D8-D12	Seat, Operator's .....	27	B14
Fenders .....	27	B14	Steering Wheel & Gear .....	31	C4
Frame .....	25	B12	Tail Lamp .....	49	D8
Grille .....	25	B12	Tool Box .....	27	B14
Hitch .....	43	D2	Transmission .....	39-41	C12-C14
Hood .....	25	B12	Wheels, Front & Rear .....	29	C2
Implement Lift Lever .....	43	D2			
Model D8 Wheel Weights .....	57	E2			

## GENERAL INFORMATION

2

### Indexes

This Parts Catalog is arranged for easy identification of Genuine CASE Service Parts. An alphabetical index is provided at the front of this Catalog to locate the major groups or assemblies. A numerical index at the rear of the Catalog gives the part numbers and the pages on which they are described.

### Illustrations

All parts are illustrated in "Exploded Views" which show the individual parts in their normal relationship to each other. Reference numbers are used in the illustrations. These numbers correspond to those in the "Reference Number" column and are followed by the part number, description and quantity required.

### Orders

Orders should plainly specify correct part number, full description, quantity required, machine model and engine model, machine and engine serial numbers, method of shipment and shipping address.

### Changes

When changes to the machine make it necessary, revised pages for this book will be issued. The revised pages will be issued with the same page number as those they replace and the "issue" number and date will be advanced.

It is imperative that revised Parts Book pages be inserted into their respective Parts Books as soon as received. Failure to do so will lead to confusion and defeat the purpose of the book.

### Indented Description

Indented parts in the descriptive list are a part of the preceding assembly or sub-assembly. The quantity shown in the "Number Required" column is the number of parts used on a machine except where parts are indented in descriptive list. In this case the quantity shown is the number required for the preceding assembly or sub-assembly.

REF.	PART NO.	DESCRIPTION	REQ'D
	A 55159	CYLINDER ASSY - rear steering	1
28	A 56208	SOCKET ASSY - rear cylinder	1
29	A 55956	PLUG - adjusting, socket assy	1
30	A 55957	SEAT - socket ball	2
31	A 56210	SPRING - socket	1
32	A 56209	SEAT - socket spring	1
33	G 45175	CLAMP ASSY - socket assy	1
	16- 836	BOLT - 1/2" x 2-1/4" N.F.hex.	1
34	132- 104	PIN - cotter, 3/16" x 3"	1
35	A 55889	STUD - ball, socket & cylinder	2
36	13- 410	BOLT - 1/4" x 5/8" N.C., hex.	4
37	92- 4	LOCKWASHER - 1/4" SAE	4

### Terms "Right Hand" and "Left Hand"

"Right Hand" and "Left Hand" sides of this machine are determined by standing at the rear of the unit and facing in the direction of forward travel.

## CASE MODEL 210 COMPACT TRACTOR

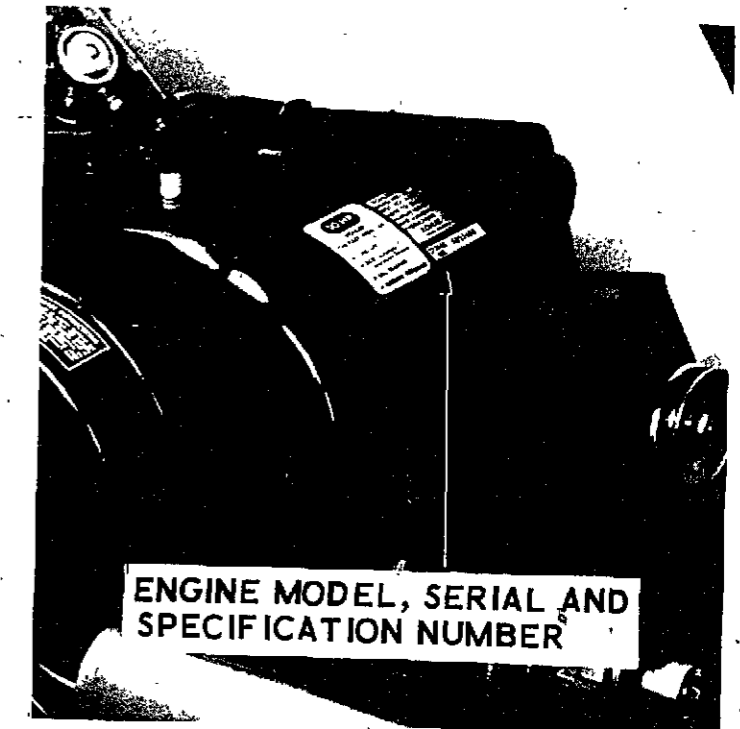
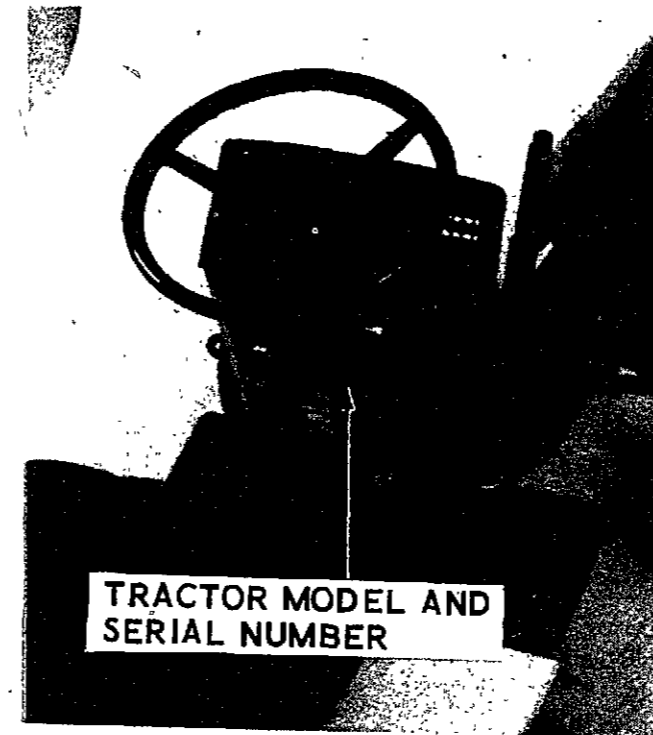

TRACTOR MODEL DESIGNATIONS	ENGINE MODEL DESIGNATIONS
210 TRACTOR	K - 241 - A C20181 ENGINE SPEC. NO. 46708D

### SERIAL NUMBERS

When using this catalog, notice the reference to serial numbers of various components noted here and listed in the "description" copy. By referring to correct serial numbers, proper parts identification will be assured.

**AIR CLEANER**

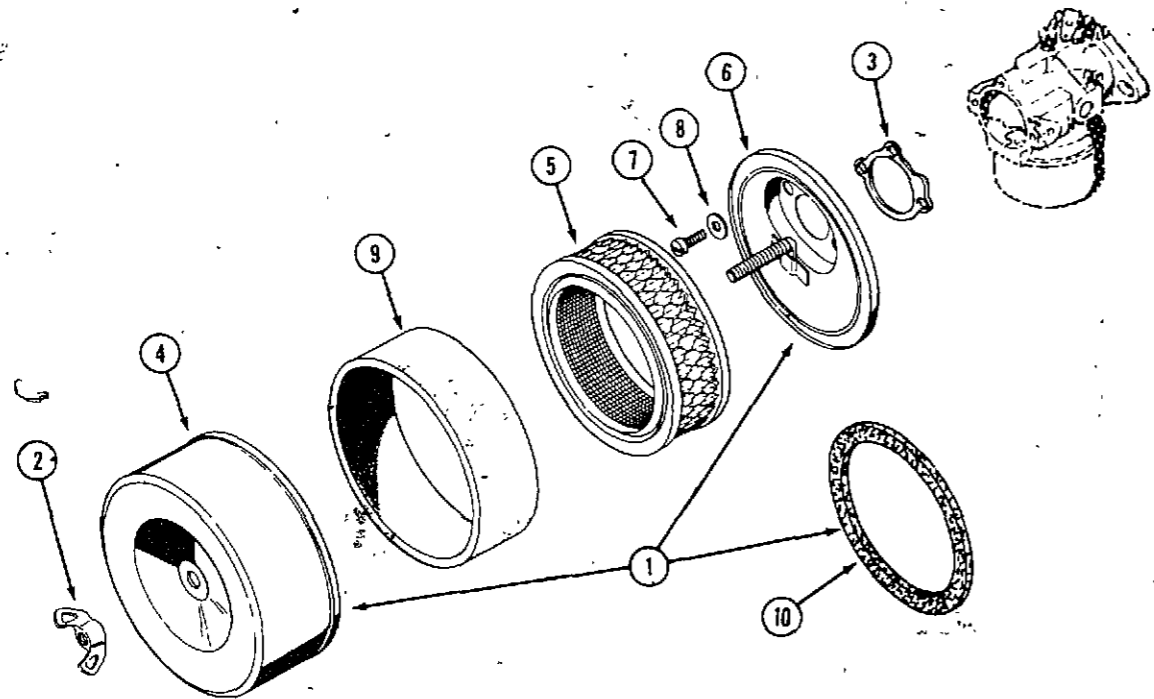

REF.	PART NO.	DESCRIPTION	REQ'D
1	KO 237895	AIR CLEANER ASSEMBLY (includes items 4,6 and 10).....	1
2	129- 409	NUT - wing 3/8" NC .....	1
3	KO 275341	GASKET - air horn .....	1
4	NSS	COVER - air cleaner (Order KO237895) .....	1
5	A 70090	ELEMENT - air cleaner .....	1
6	NSS	BASE - air cleaner (Order KO237895) .....	1
7	177- .94	SCREW - fillister head 10-32 x 5/16" .....	3
8	193- .6	WASHER - plain 3/16".....	3
9	KO 237421	PRE-CLEANER .....	1
10	KO 237423	GASKET - cover, air cleaner .....	1

**EXHAUST SYSTEM**

1	C 19053	MUFFLER - exhaust .....	1
2	C 19213	PIPE - engine exhaust .....	1
3	113- 207	BOLT - 3/8" x 1" NC hex .....	1
4	195- 525	WASHER - 3/8" plain .....	1
5	192- 21	LOCKWASHER - 3/8" .....	1
6	129- 103	NUT - 3/8" NC hex .....	1
7	111- 256	BOLT - 5/16" x 1-1/4" round head square neck NC .....	1
8	C 19449	CLAMP - muffler .....	1
9	192- 20	LOCKWASHER - 5/16" .....	1
10	129- 102	NUT - 5/16" NC hex .....	1

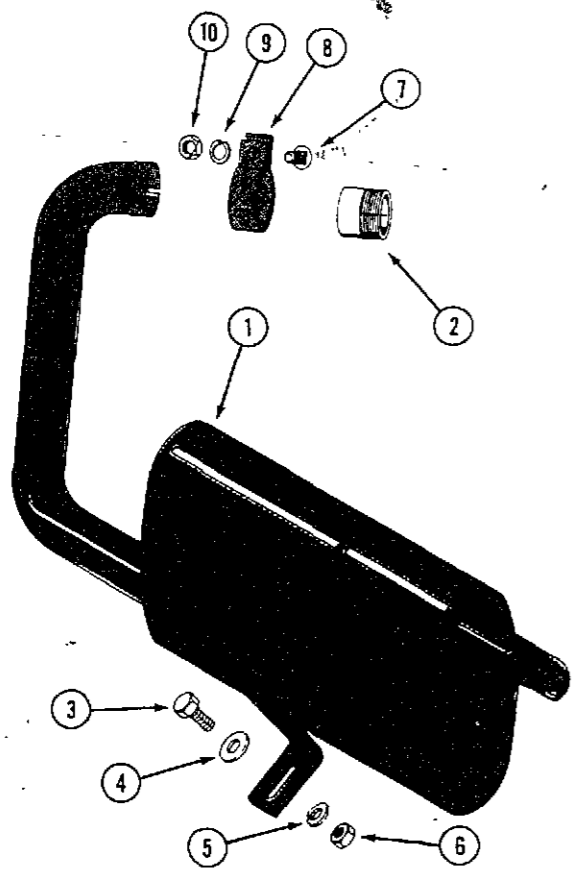

**CRANKCASE BREATHER**

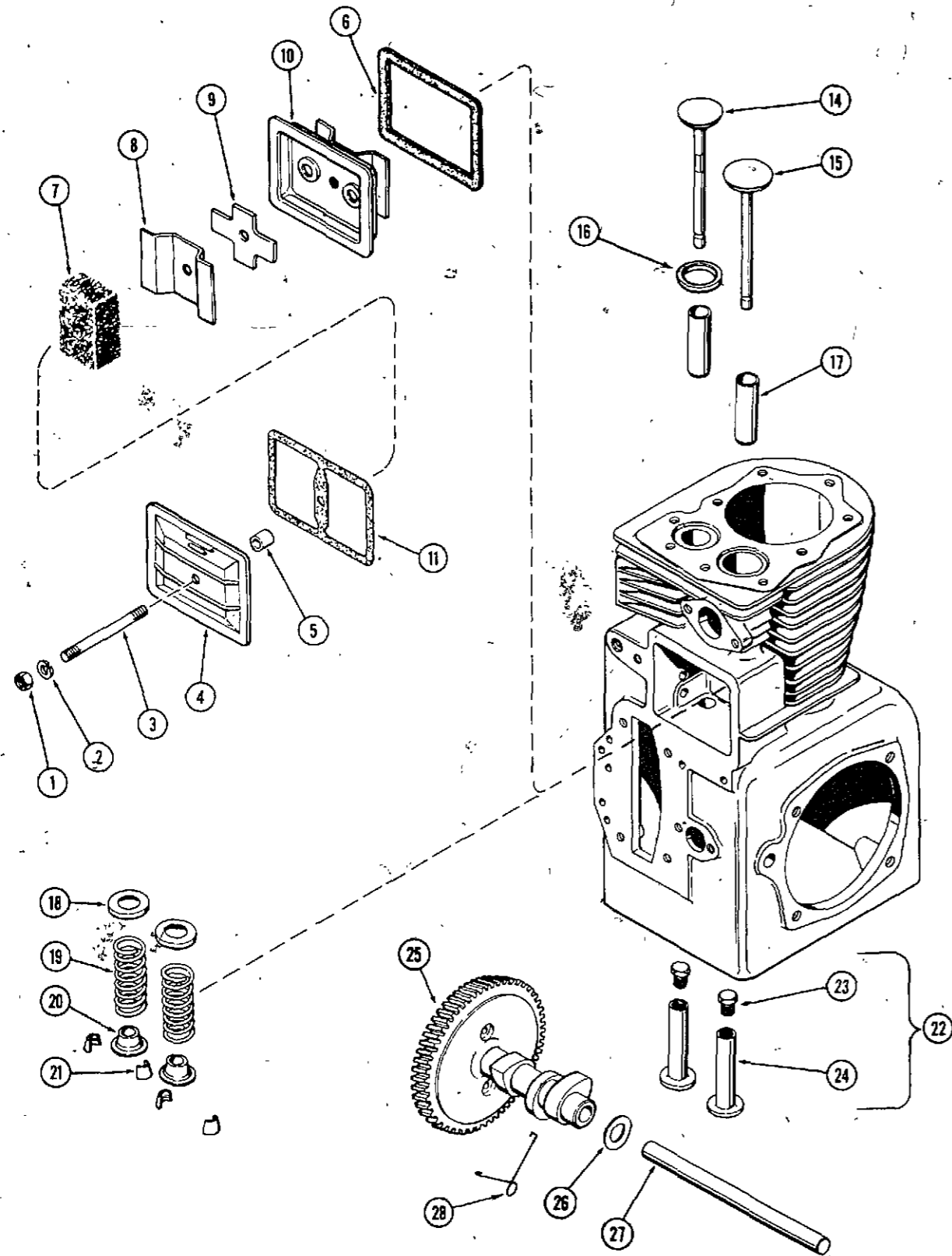

REF. PART NO.	DESCRIPTION	REQ'D
1 129- 409	NUT - 1/4" NC hex	1
2 92- 4	LOCKWASHER - 1/4"	1
3 KO 275220	STUD - valve cover	1
4 KO 275143	COVER - valve	1
5 KO 231032	SEAL - breather	1
6 KO 235048	GASKET - breather plate	1
7 KO 235118	FILTER - breather	1
8 KO 235117	BAFFLE - breather	1
9 KO 235047	REED - breather	1
10 KO 235631	PLATE - breather	1
11 KO 275144	GASKET - valve cover	1

**CAMSHAFT AND VALVES**

14 KO 235826	VALVE - exhaust	1
15 KO 235008	VALVE - intake	1
16 KO 230170	INSERT - exhaust valve seat	1
17 KO 235007-S	GUIDE - valve	2
18 KO 235011	SEAT - valve spring	2
19 KO 235010	SPRING - valve	2
20 KO 230011	RETAINER - valve spring	2
21 KO 240013	LOCK - valve retainer	4
22 KOD 235327	LIFTER ASSEMBLY	2
23 NSS	SCREW - tappet adjusting	1
24 NSS	LIFTER - valve	1
25 C 23086	CAMSHAFT ASSEMBLY	1
26 KO 275066	SPACER - camshaft, .005"	UAR
26 KO 275067	SPACER - camshaft, .010"	UAR
27 KO 235053	PIN - camshaft	1
28 V 34346	SPRING - actuating	1

CRANKSHAFT, PISTON - CONNECTING ROD

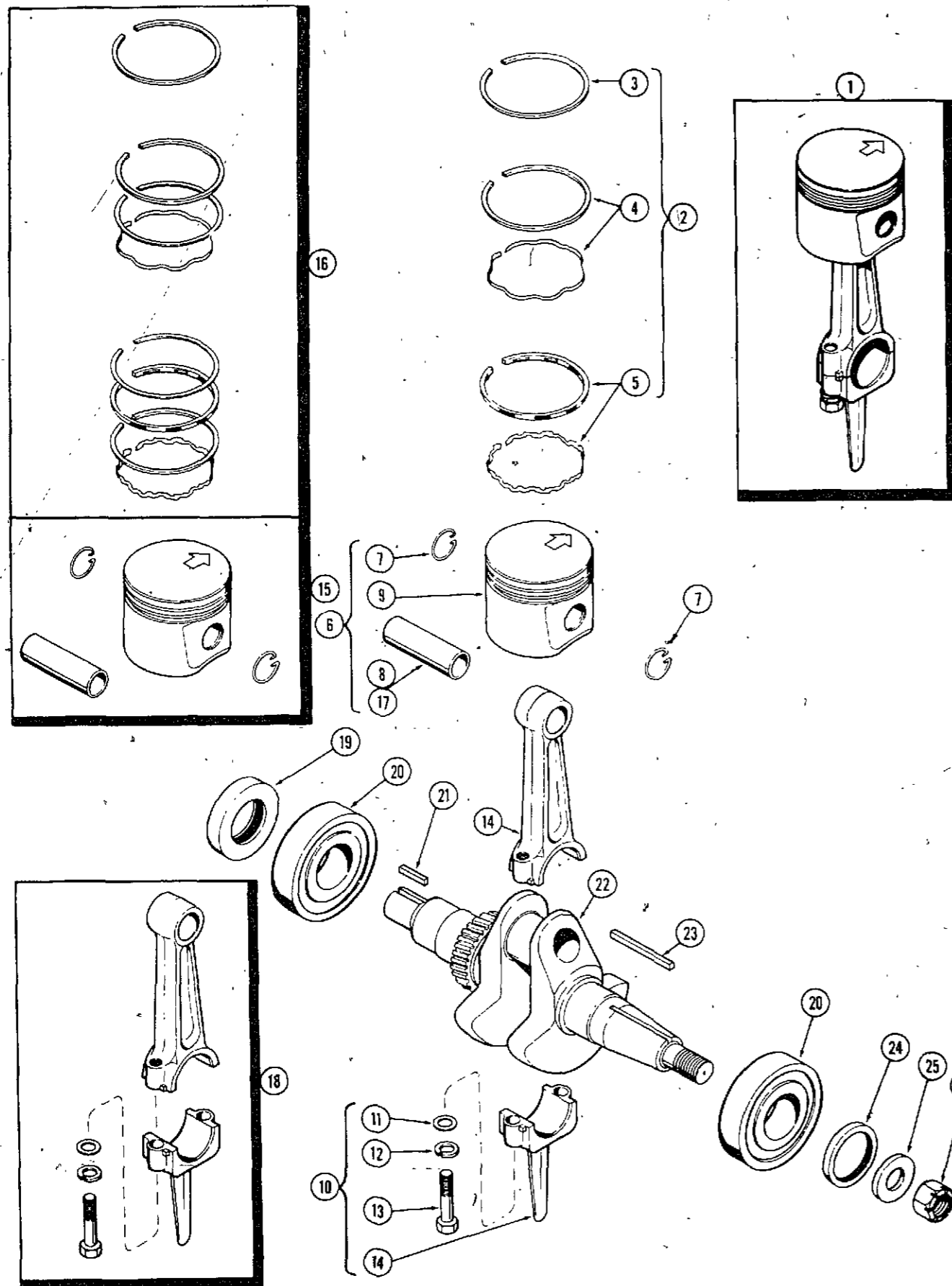

REF. PART NO.	DESCRIPTION	REQ'D
1 NSS	PISTON AND ROD ASSEMBLY (Std. size)	1
2 KO 235287	RING*SET - piston (For oversize, see item 16)	1
3 NSS	RING - top compression	1
4 NSS	RING - 2nd compression (Includes expander)	1
5 NSS	RING - oil (Includes expander)	1
6 KOA 235611	PISTON ASSEMBLY (For oversize, see item 15)	1
7 KO 235004	RETAINER - piston pin	2
8 NSS	PIN - piston	1
9 NSS	PISTON	1
10 KOA 235139	CONNECTING ROD AND ASSEMBLY (For undersize, see item 18)	1
11 KO 235003	WASHER - special	1
12 92- 6	LOCKWASHER	2
13 C 22698	SCREW - cap, connecting rod	2
14 NSS	ROD - connecting	1
15 KOA 235567	PISTON ASSEMBLY - .003" oversize (use std. ring set)	1
15 KOA 235569	PISTON ASSEMBLY - .010" oversize	1
15 KOA 235571	PISTON ASSEMBLY - .020" oversize	1
15 KOA 235616	PISTON ASSEMBLY - .030" oversize	1
16 KO 235288	RING SET - piston - .010" oversize	1
16 KO 235289	RING SET - piston .020" oversize	1
16 KO 235290	RING SET - piston .030" oversize	1
17 KO 235573	PIN - piston, .005" oversize	1
18 C 18101	CONNECTING ROD ASSEMBLY - .010" undersize	1
19 R 16287	OIL SEAL - crankshaft rear	1
20 40035	BEARING - crankshaft ball	2
21 W 5063-S	KEY - 1/4" Sq. x 3/4" (Pump Coupling)	1
22 KO 236364	CRANKSHAFT	1
23 A 27001	KEY - flat 3/16" x 3/16" x 1-3/8" (Flywheel)	1
24 C 18097	OIL SEAL - crankshaft front	1
25 195- 541	WASHER - 5/8"	1
26 131- 301	NUT - special Marsden 5/8" NF	1

ENGINE BLOCK AND ATTACHING PARTS

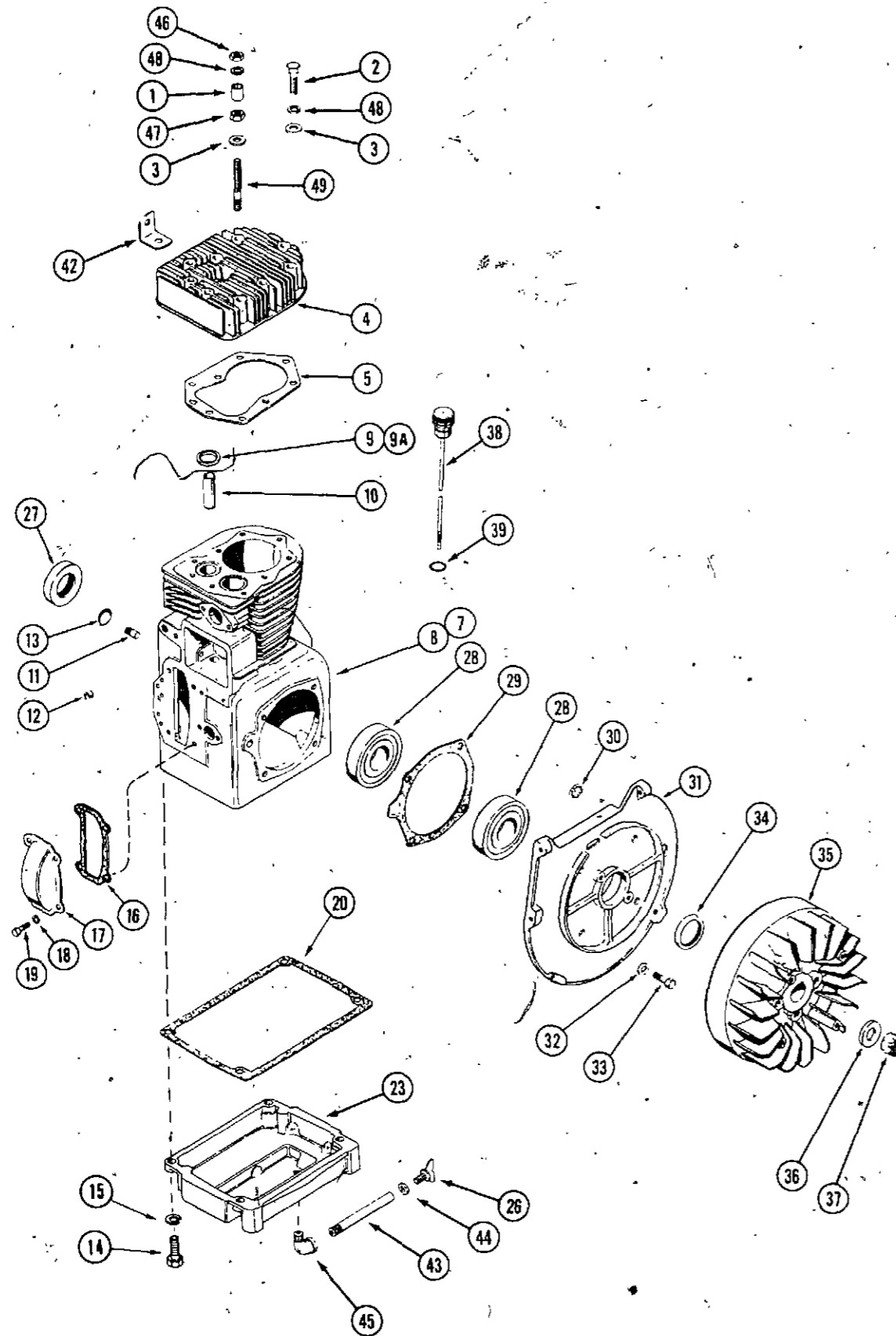

REF. PART NO.	DESCRIPTION	REQ'D
1 C 21814	SPACER - cylinder head	6
2 KO 270158	BOLT - cylinder head 3/8 x 1-1/2" NC hex	3
3 KO 270889	WASHER - cylinder head bolt	9
4 KO 236675	HEAD - cylinder	1
5 KO 237658	GASKET - head	1
7 KOA 237871	BLOCK ASSEMBLY - cylinder, mini (includes camshaft assembly, piston assembly, ring set, one main bearing, valves, rod assembly, governor gear assembly and cross shaft)	1
8 KOA 237694	BLOCK ASSEMBLY - cylinder, short (includes camshaft ass'y crankshaft and seals, piston assembly, ring set, main bearings; plate and gasket, rod assembly, valves, governor gear assembly and cross shaft)	1
9 KO 230170	INSERT - exhaust valve	1
10 KO 235007-S	GUIDE - valve	2
11 KO 235125-S	SHAFT - stub governor	1
12 C 18103	BEARING - needle, governor shaft	1
13 41- 18	PLUG - expansion	1
14 113- 409	BOLT - 3/8" x 1-1/4" NC hex plated	4
15 92- 6	LOCKWASHER - 3/8" plated	4
16 KO 235025	GASKET - camshaft cover	1
17 KO 235026	COVER - camshaft gear	1
18 92- 4	LOCKWASHER - 1/4" plated	4
19 13- 48	BOLT - 1/4" x 1/2" NC plated	4
20 KO 235353	GASKET - oil pan	1
23 C 22699	BASE - oil pan	1
26 C 14399	PLUG - oil drain	1
27 R 16287	OIL SEAL - crankshaft rear	1
28 40035	BEARING - crankshaft ball	2
29 KO 235757	GASKET - bearing plate	1
29 KO 235070	GASKET - shim, .010"	1
30 205- 27	PLUG - button, timing hole	1
31 C 22700	PLATE - bearing	1
32 92- 6	LOCKWASHER - 3/8" plated	4
33 113- 207	BOLT - 3/8" x 1" NC plated	4
34 C 18097	OIL SEAL - crankshaft front	1
35 KO 235818	FLYWHEEL	1
36 195- 545	WASHER - special, plated	1
37 131- 309	NUT - special, Marsden	1
38 C 14953	DIPSTICK ASSEMBLY	1
39 A 27365	"O" RING - dipstick	1
42 KO 235748	STRAP - lifting	1
43 C 18814	NIPPLE - oil drain extension	1
44 C 14906	GASKET - plug, oil drain	1
45 221- 1412	ELBOW - street	1
46 129- 143	NUT - 3/8" NC hex, jam	6
47 129- 103	NUT - 3/8" NC hex	6
48 92- 6	LOCKWASHER - 3/8"	9
49 KO 237277	STUD - cylinder head	6

ENGINE GASKET AND SEAL KIT

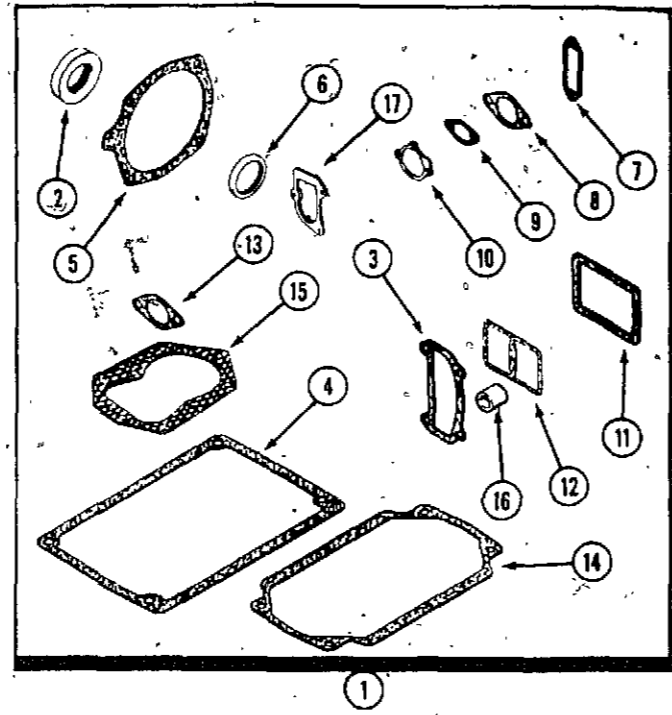

REF. PART NO.	DESCRIPTION	REQ'D
1	KO 237727	1
2	R 16287	1
3	KO 235025	1
4	KO 235353	1
5	KO 235757	6
5	KO 235070	UAR
6	C 18097	1
7	V 34423	1
8	C 23108	1
9	C 22738	1
10	KO 275341	1
11	KO 235048	1
12	KO 275144	1
13	C 10372	1
14	KO 235057	1
15	KO 237658	1
16	KO 231032	1
17	KO 237064	1

DESCRIPTION	REQ'D
KIT - engine gasket	1
SEAL - crankshaft, rear	1
GASKET - camshaft cover	1
GASKET - oil pan	1
GASKET - bearing plate	6
GASKET - shim (.010")	UAR
SEAL - crankshaft, front	1
GASKET - breaker cover	1
GASKET - carburetor flange	1
GASKET - fuel pump flange	1
GASKET - carburetor air horn	1
GASKET - breather plate	1
GASKET - valve cover	1
GASKET - exhaust	1
GASKET - pan (not used)	1
GASKET - cylinder head	1
SEAL - breather	1
GASKET - oil fill tube ( used on 14 HP)	1

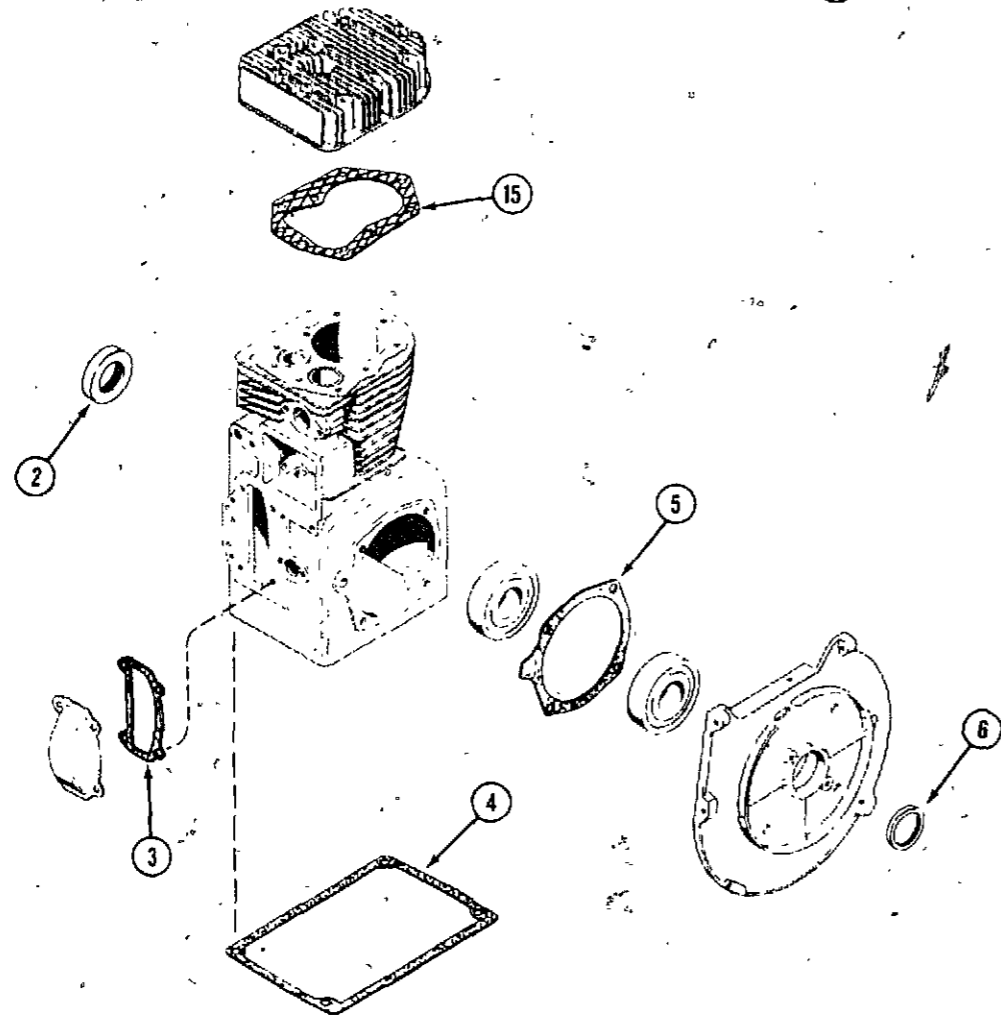

**BAFFLES AND SHROUDS**

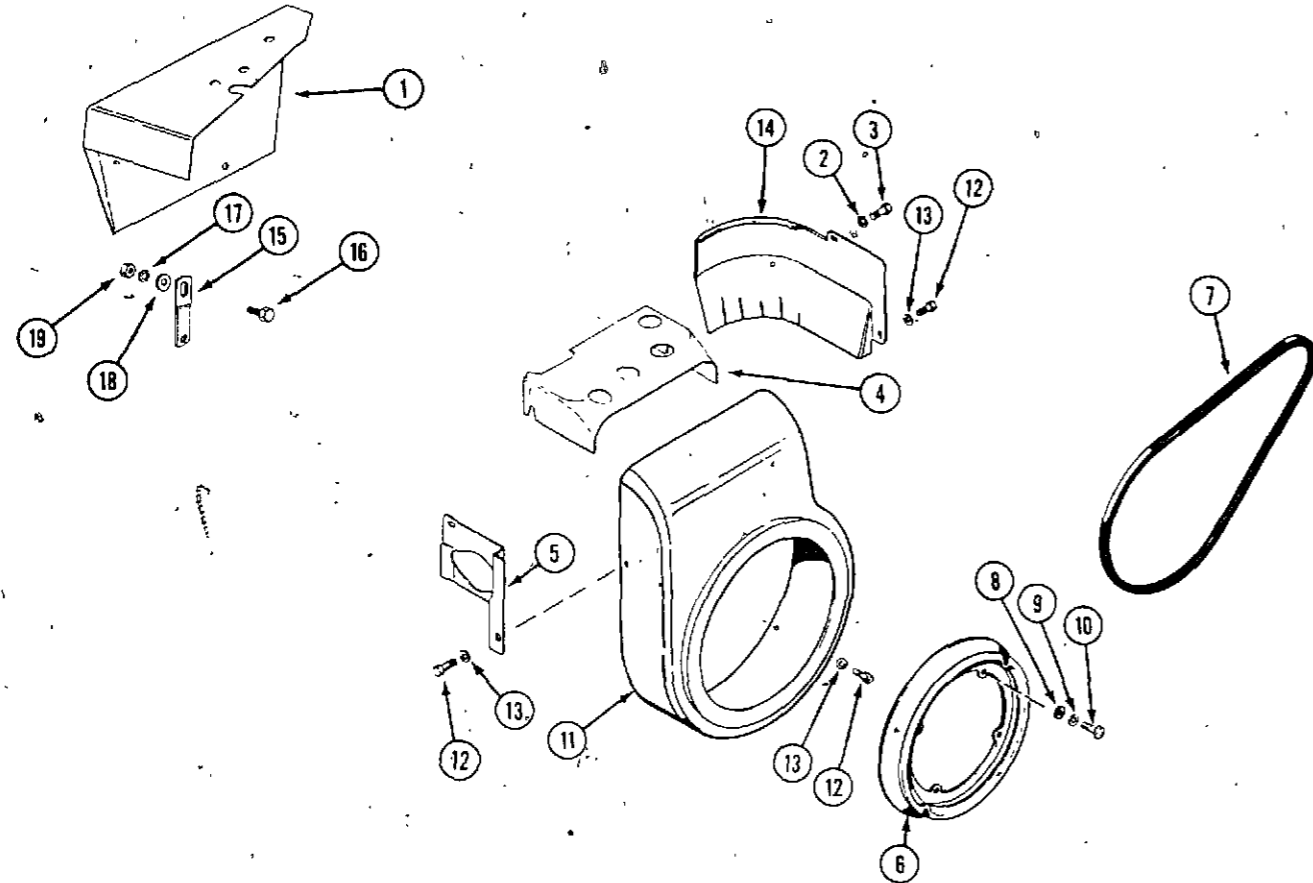

REF. PART NO.	DESCRIPTION	REQ'D
1 C 18989	DEFLECTOR - engine air	1
2 92- 4	LOCKWASHER - 1/4" zinc plated	2
3 13- 48	BOLT - 1/4" x 1/2" NC hex, zinc plated	2
4 KO 237520	BAFFLE - cylinder head	1
5 KO 235652	BAFFLE - carburetor side air	1
6 KO 235207	PULLEY - starter	1
7 C 14345	BELT - drive, starter-generator	1
8 193- 107	WASHER - 1/4" zinc plated	1
9 92- 4	LOCKWASHER - 1/4" zinc plated	4
10 175- 436	SCREW - 1/4" x 5/8" NC truss head Phillips, zinc plated	4
11 KO 235901	HOUSING - blower	1
12 13- 410	BOLT - 1/4" x 3/4" NC hex, zinc plated	4
13 92- 4	LOCKWASHER - 1/4" zinc plated	4
14 KO 235054	BAFFLE - cylinder	1
15 C 19021	SUPPORT - engine air deflector	1
16 113- 118	BOLT - 5/16" x 5/8" NC hex	1
17 192- 20	LOCKWASHER - 5/16"	1
18 195- 521	WASHER - 5/16" plain	1
19 129- 102	NUT - 5/16" NC hex	1

**FUEL SYSTEM**

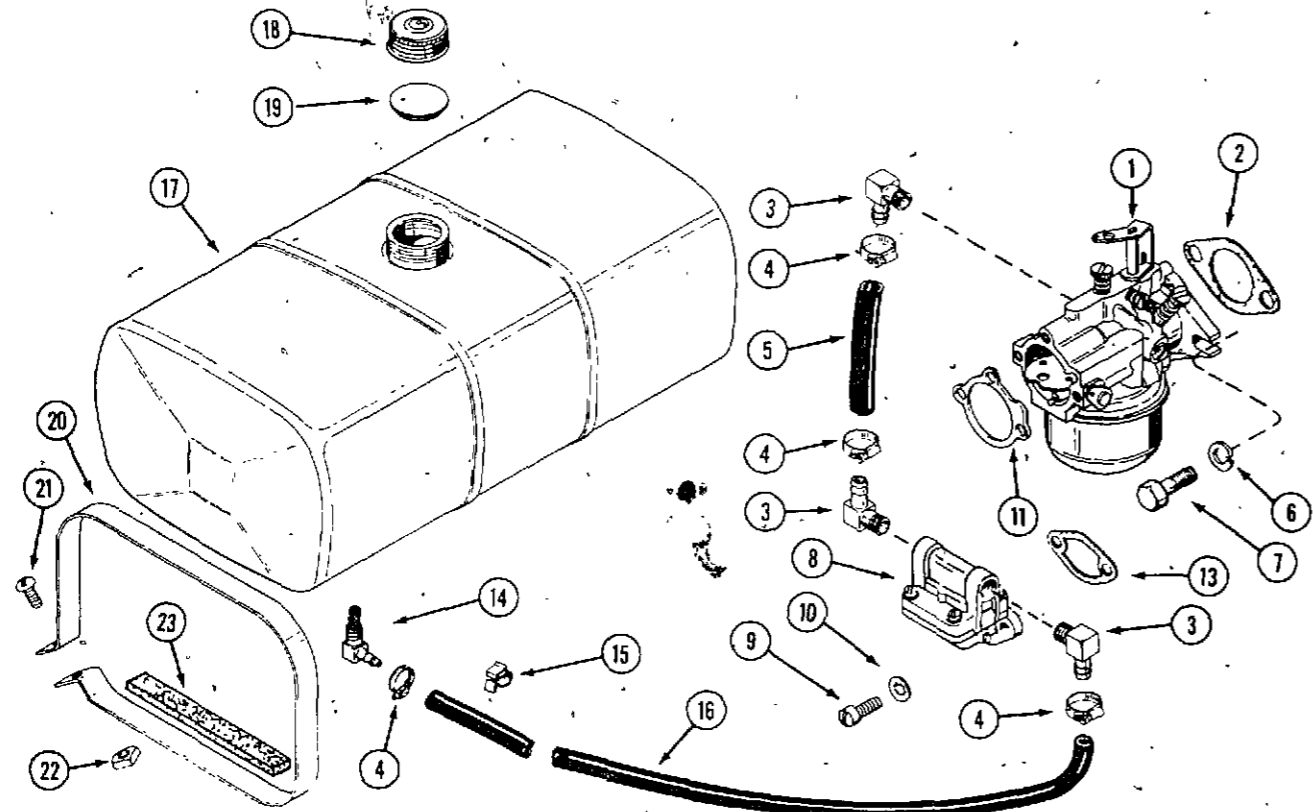

1 C 23049	CARBURETOR ASSEMBLY -	1
2 C 23108	GASKET - carburetor flange	1
3 C 10678	ELBOW - fuel pump and carburetor	3
4 214- 251	CLAMP - hose	4
5 V 34404	HOSE - carburetor 5-1/5"	1
6 192- 20	LOCKWASHER - 5/16"	2
7 113- 103	BOLT - 5/16" x 1" NC hex	2
8 KOA 235845	PUMP - fuel, 10 h.p. (Repairs page 17)	1
9 71 412	SCREW - 1/4" x 3/4" NC fillister head	2
10 193- 28	LOCKWASHER - 1/4"	2
11 KO 275341	GASKET - air horn	1
13 C 22738	GASKET - fuel pump mounting	1
14 C 10657	ELBOW ASSEMBLY - fuel tank	1
15 C 14157	CLIP - fuel line	2
16 C 17574	HOSE - fuel line 43"	1
17 C 16363	TANK - fuel	1
18 C 11529	CAP - fuel tank (Includes insert)	1
19 C 11545	INSERT - fuel cap	1
20 C 16796	STRAP - fuel tank mounting	2
21 173- 215	SCREW - 1/4 x 1/2" NC round head, machine, zinc plated	2
22 129- 504	NUT - square 1/4" NC	2
23 C 14690	CUSHION - fuel tank	2



**C 23049 CARBURETOR**

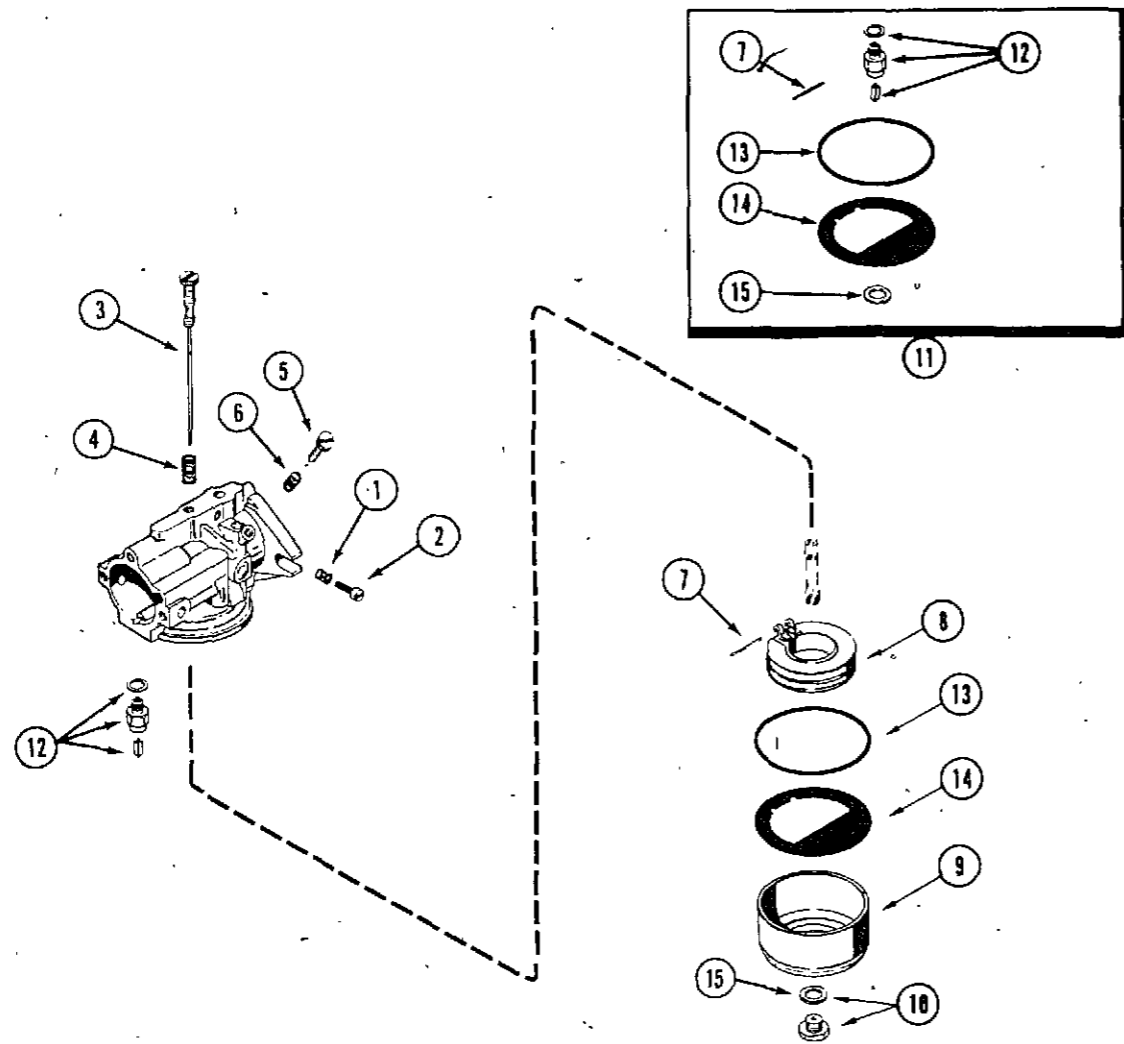

REF. PART NO.	DESCRIPTION	REQ'D
C 23049	CARBURETOR ASSEMBLY	1
1 KO 200380	SPRING - tension, idle adjust	1
2 A 72092	SCREW - idle adjust	1
3 A 72077	NEEDLE - main fuel adjust	1
4 KO 200383	SPRING - main fuel adjust	1
5 A 72099	NEEDLE - idle adjust	1
6 KO 200380	SPRING - idle fuel adjust	1
7 F 19892	PIN - float	1
8 A 72078	FLOAT - carburetor	1
9 KO 235448	BOWL - carburetor	1
10 KO 235447	SCREW AND GASKET ASSEMBLY - carburetor bowl	1
11 A 72103	KIT - carburetor repair	1
12 NSS	INLET NEEDLE AND SEAT ASSEMBLY	1
13 NSS	GASKET - bowl ring	1
14 NSS	GASKET - bowl baffle	1
15 A 72083	GASKET - bowl screw	1
F 19892	PIN - float	1

**FUEL PUMP**

1 KO 230675	KIT- fuel pump for KOA235845 pump	1
NSS	SPRING - fuel pump valve	2
NSS	VALVE	2
NSS	GASKET - valve	1
NSS	DIAPHRAGM ASSEMBLY	1
2 C 22738	GASKET - fuel pump mounting	1

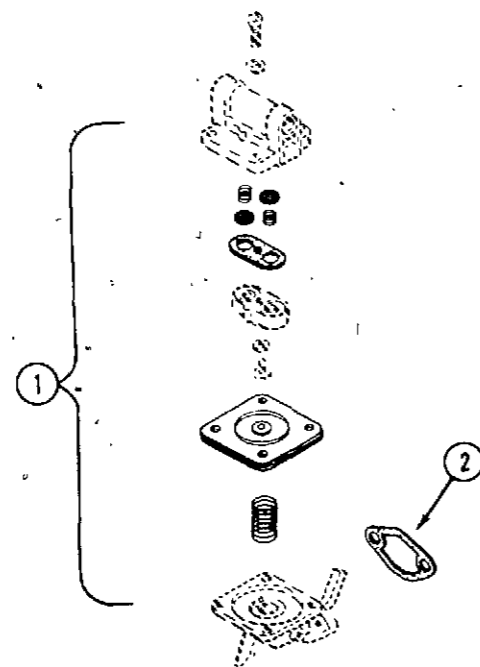

**CHOKE, THROTTLE AND GOVERNOR**

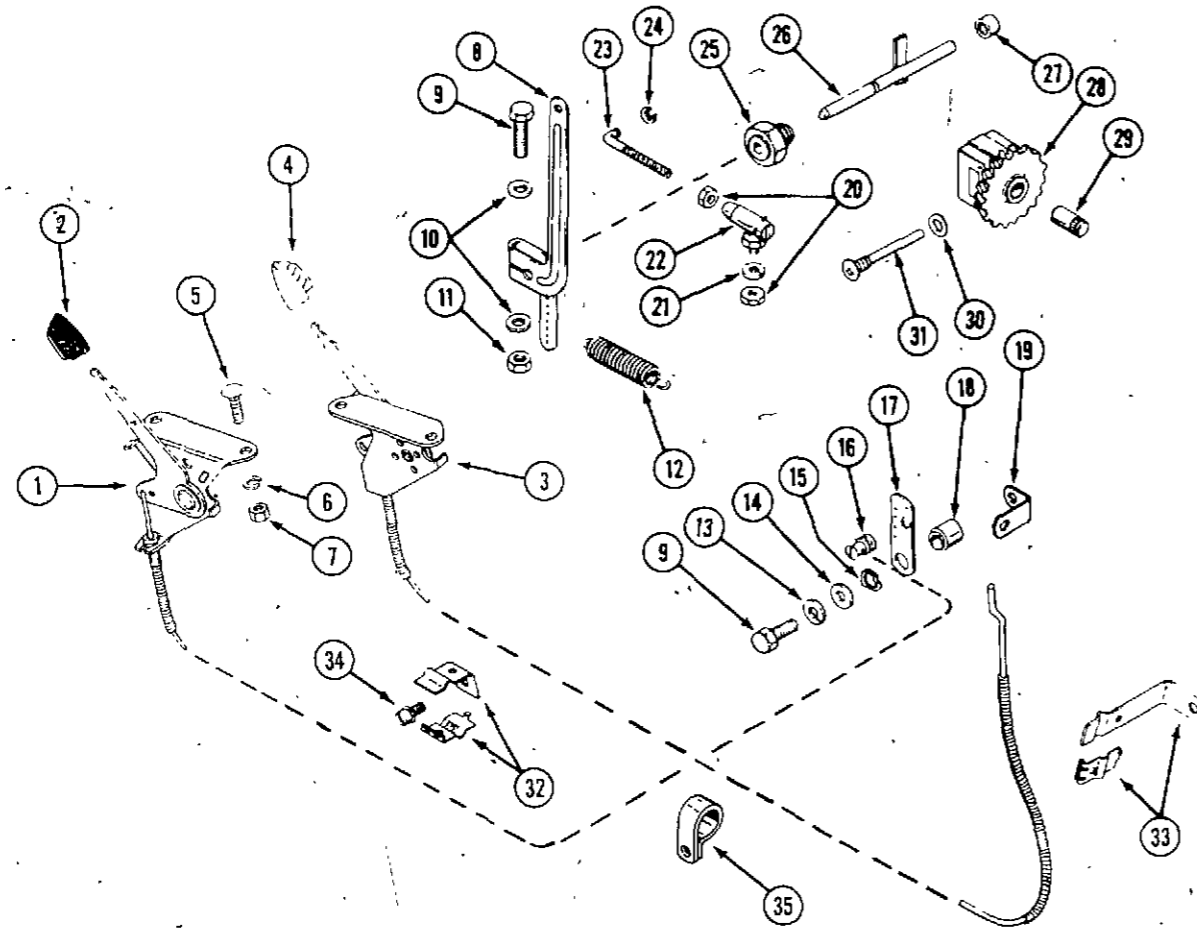

REF.	PART NO.	DESCRIPTION	REQ'D
1	C 16449	CONTROL - throttle	1
2	C 12224	HANDLE - throttle control, black	1
3	C 16448	CONTROL - choke	1
4	C 14506	HANDLE - choke control, white	1
5	111- 1	BOLT - 10-24 x 1/2" round head, square neck	2
6	192- 18	LOCKWASHER - #10 Std. plated	2
7	129- 17	NUT - #10-24 plated	2
8	KOA 237653	LEVER - governor	1
9	113- 17	BOLT - 1/4" x 1-1/4" NC hex	2
10	195- 518	WASHER - 1/4" plated	2
11	129- 409	NUT - 1/4" hex	1
12	KO 235496	SPRING - governor	1
13	92- 4	LOCKWASHER - 1/4" plated	1
14	C 18098	WASHER - thrust	1
15	KO 275690	WASHER - wavy	1
16	HO 43034	CLAMP - swivel, wire	1
17	KO 235086	LEVER - speed control	1
18	KO 235085	SPACER - speed control bracket	1
19	KO 235084	BRACKET - high speed stop	1
20	129- 37	NUT - #10-32 hex	2
21	92- 3	LOCKWASHER - 3/16" plated	1
22	C 23147	JOINT - ball	1
23	KO 235277	ROD - throttle	1
24	KO 235278	RING - retaining, throttle rod	1
25	KO 235476	BUSHING - governor cross shaft	1
26	KO 237455	SHAFT ASSEMBLY - governor cross	1
27	V 34418	BEARING - needle governor shaft	1
28	KOA 237031	GEAR ASSEMBLY - governor	1
29	KO 235125-S	SHAFT - governor stub	1
30	C 18099	WASHER - governor stop pin	1
31	V 34416	PIN - governor stop	1
32	KOA 237559	BRACKET - throttle cable	1
33	KOA 236919	BRACKET - choke cable	1
34	V 34421	SCREW - #10 x 3/8" NC fillister head	1
35	C 21679	CLAMP - choke & throttle cable	1

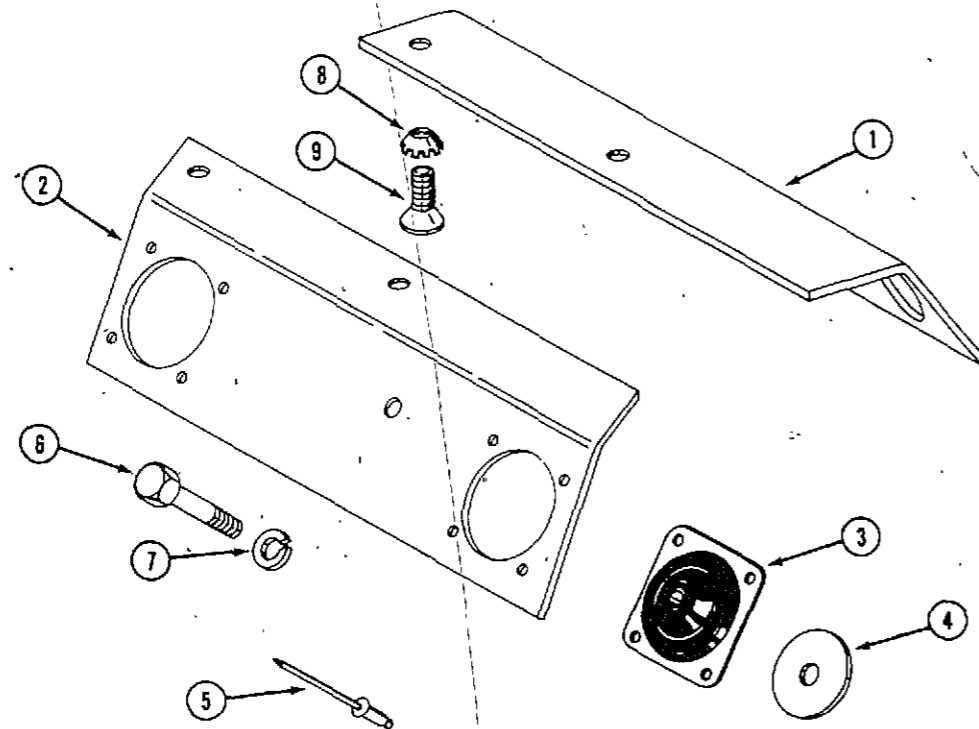

**ENGINE MOUNTING PLATE**

REF.	PART NO.	DESCRIPTION	REQ'D
1	C 17717	PLATE - engine mount L.H.	1
2	C 17718	PLATE - engine mount, R.H.	1
3	C 18793	MOUNT - engine	4
4	C 18794	WASHER - snubbing	4
5	151- 138	RIVET - pop 3/16"	16
6	113- 219	BOLT - 3/8" x 2" NC hex	4
7	192- 21	LOCKWASHER - 3/8"	4
8	193- 56	LOCKWASHER - 3/8" countersunk external tooth	4
9	164- 50	BOLT - flat head, hex. socket	4

**PTO CLUTCH & LINKAGE**

(USED PRIOR TO S/N 9685953)

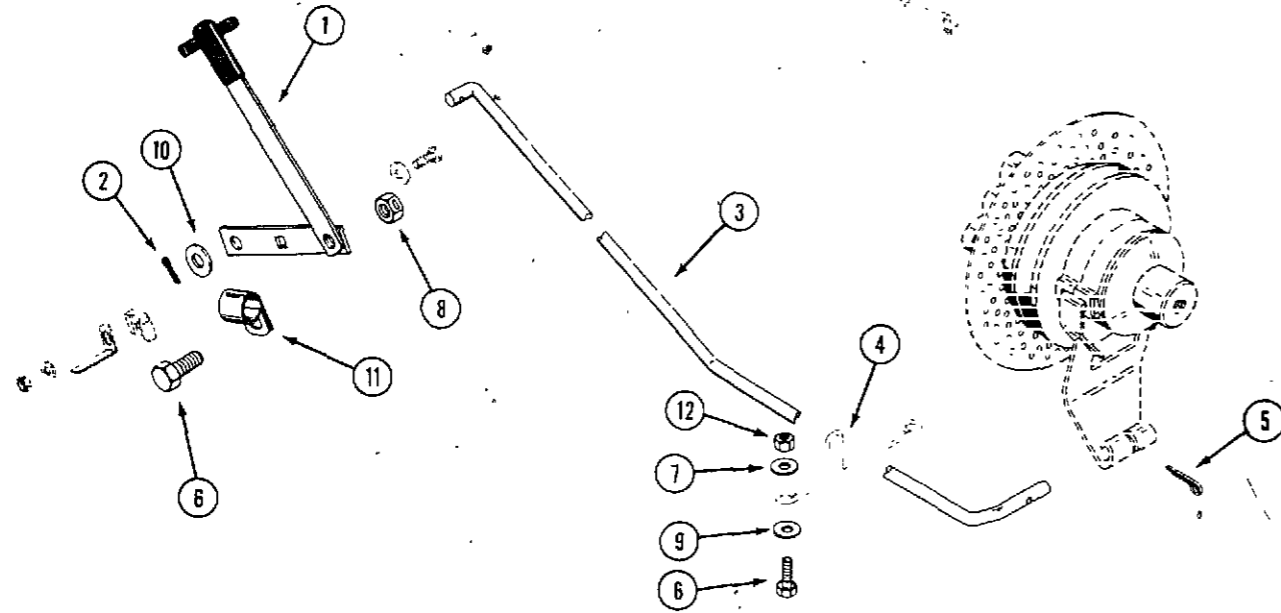

REF. PART NO.	DESCRIPTION	REQ'D
1 C 19362	LEVER - clutch	1
2 132- 46	PIN - cotter 1/8" x 3/4"	1
3 C 18990	ROD - clutch	1
4 C 18825	RETAINER - clutch rod	1
5 132- 48	PIN - cotter 1/8" x 1"	1
6 113- 207	BOLT - 3/8" x 1" NC hex	3
7 195- 126	WASHER - spacer	2
8 131- 118	LOCKNUT - 3/8" NC hex	1
9 195- 104	WASHER - 3/8"	2
10 195- 525	WASHER - 3/8"	1
11 C 21679	CLAMP - cable guide	1
12 131- 178	LOCKNUT - 3/8" NC hex	2

**PTO CLUTCH & LINKAGE**

(USED S/N 9685953 AND AFTER)

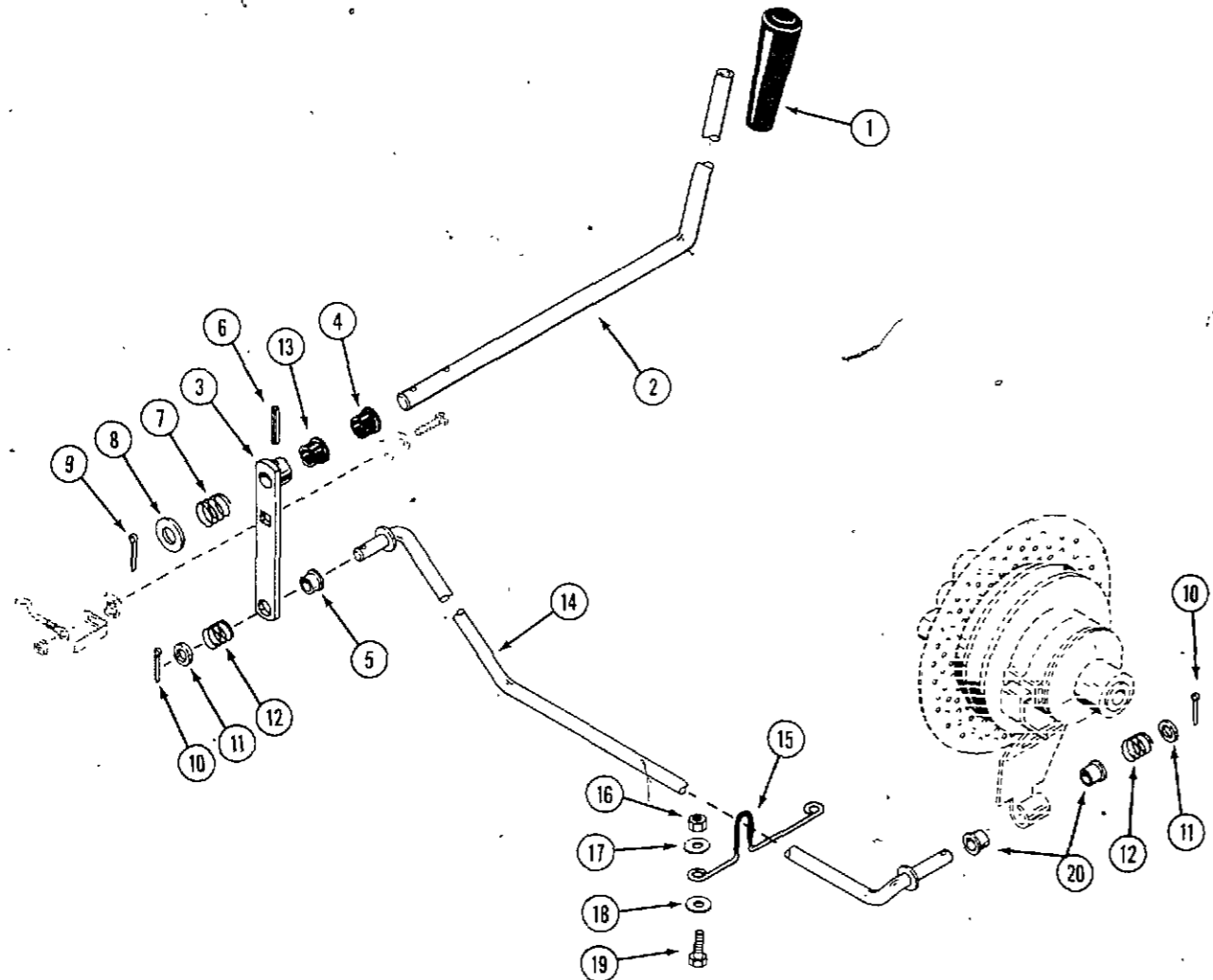

REF. PART NO.	DESCRIPTION	REQ'D
1 A 37247	KNOB - lever, PTO	1
2 C 20037	LEVER - PTO engaging	1
3 C 20035	ARM ASSEMBLY - PTO	1
4 353- 462	BUSHING - lever, dash tower	1
5 C 20093	BUSHING - fliplock	1
6 138- 96	PIN - roll 3/16 x 1"	1
7 C 20036	SPRING - lever, PTO	1
8 A 39519	WASHER - nylon	1
9 132- 91	PIN - cotter 3/16 x 1"	1
10 132- 48	PIN - cotter 1/8 x 1"	2
11 C 14906	WASHER - nylon 3/8"	2
12 C 19867	SPRING - clutch rod	2
13 353- 442	BUSHING - heyco	1
14 C 20107	ROD - clutch	1
15 C 19767	GUIDE - clutch rod	1
16 131- 178	NUT - lock 3/8" n.c. hex	2
17 195- 104	WASHER - 3/8"	2
18 195- 126	WASHER - spacer (used on models without hyd. lift)	2
19 113- 207	BOLT - 3/8 x 1" NC hex	2
20 C 20053	BUSHING - nylon	2

CLUTCH ASSEMBLY (PTO)

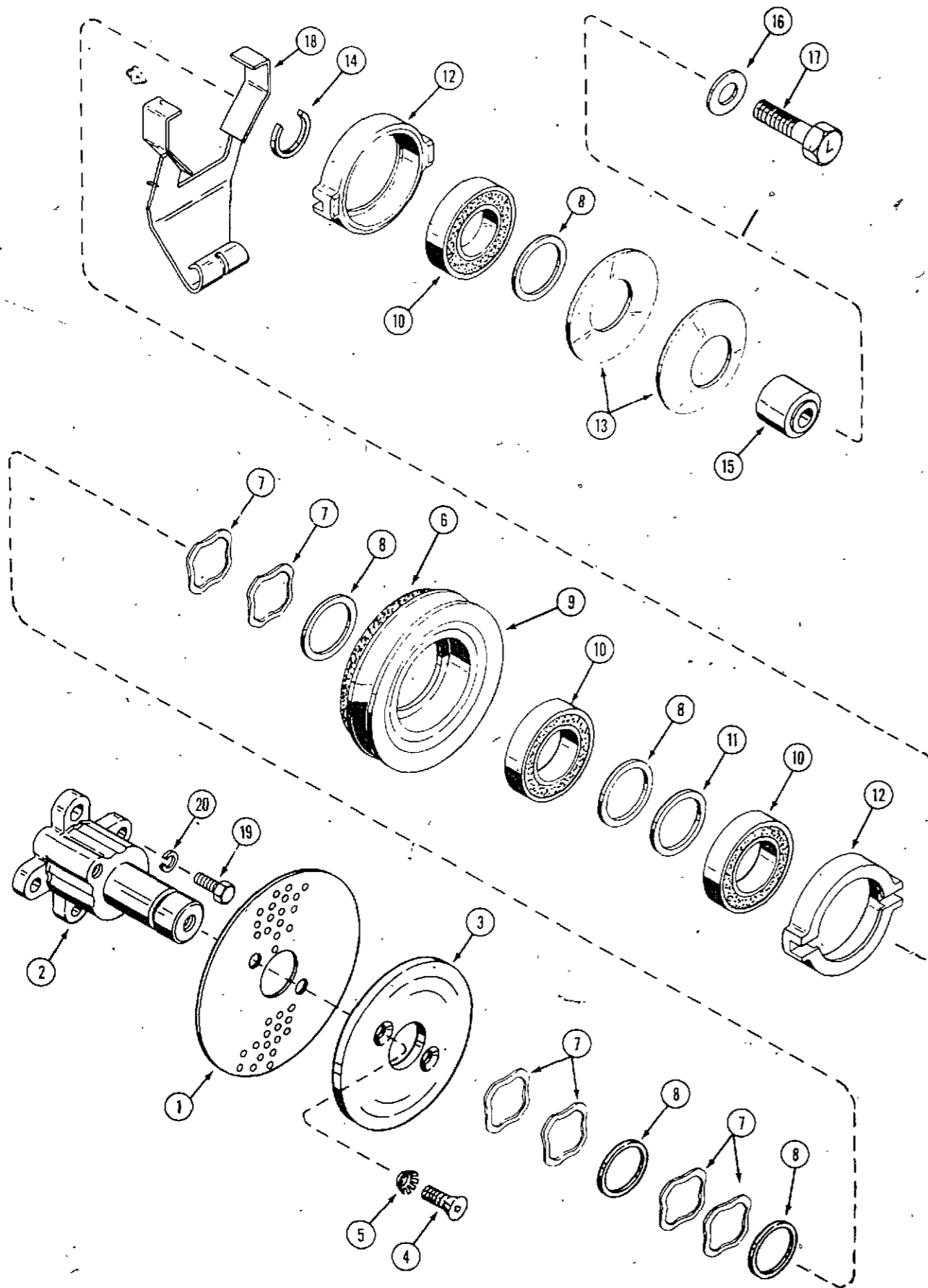

REF.	PART NO.	DESCRIPTION	REQ'D
	C 19803	CLUTCH ASSEMBLY - less screen	1
1	C 15721	SCREEN - grass	1
2	C 18907	HUB - clutch	1
3	C 15718	PLATE - clutch	1
4	164- 40	BOLT - 5/16" x 3/4" NC flat head socket	2
5	193- 76	LOCKWASHER - 5/16" countersunk external tooth	2
6	C 14291	DISC - friction	1
7	C 15515	WASHER - spring	6
8	C 15557	WASHER - spacer .050"	5
9	C 22671	PULLEY ASSEMBLY - clutch (includes disc)	1
10	C 23245	BEARING - cam and pulley	3
11	C 21596	WASHER - spacer, .005"	UAR
12	NSS	CAM - clutch (used prior to S/N 9685953 must service with (2) C23033 cams and (1) C23506 arm	2
12	NSS	CAM - clutch (used S/N 9685953 and after) must service with (2) C23033 cams and (1) C23391 arm	2
13	C 16786	SPRING - clutch load	2
14	F 59014	RING - retaining	1
15	C 18908	SPACER - hub	1
16	O 2815N	WASHER - fan 17/32"	1
17	C 18940	BOLT - 1/2" x 1-3/4" NC hex L.H. threads	1
18	C 23506	ARM - engaging (used prior to S/N 9685953)	1
18	C 23391	ARM - engaging (used S/N 9685953 and after)	1
19	113- 207	BOLT - 3/8" x 1" NC hex ZP	4
20	192- 21	LOCKWASHER - 3/8"	4
	C 19472	KIT - clutch stub shaft (includes items 2, 8, 11, 14, 15, 16, 17 and 19)	1

**HOOD, FRAME AND GRILLE**

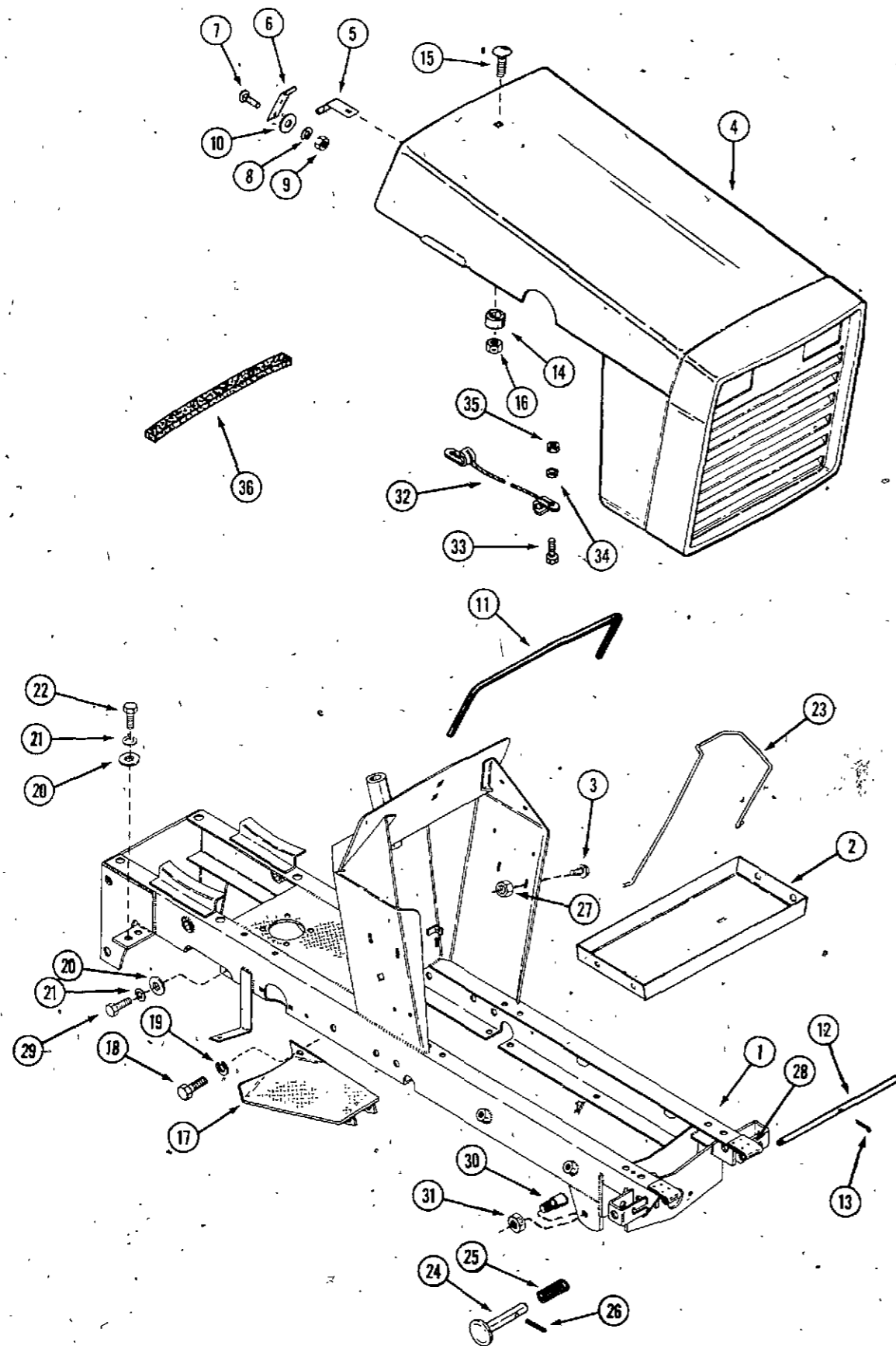

REF.	PART NO.	DESCRIPTION	REQ'D
1	C 18942	FRAME*- main (used prior to S/N 9685953)	1
1	C 19811	FRAME - main (Used S/N 9685953 and after)	1
2	C 16170	TRAY - battery	1
3	121- 106	SCREW - 5/16" x 1/2" whizlock (used prior to S/N 9685953)	4
4	C 16364	HOOD AND GRILLE ASSEMBLY (used prior to S/N 9685953)	1
4	C 20056	HOOD AND GRILLE ASSEMBLY (used S/N 9685953 and after)	1
5	C 15183	SPRING - hood latch (used prior to S/N 9685953)	1
6	C 15184	LATCH - hood (used prior to S/N 9685953)	1
7	111- 1	BOLT - #10 x 1/2" NC round head, square neck (used prior to S/N 9685953)	2
8	192- 18	LOCKWASHER - #10 (used prior to S/N 9685953)	2
9	129- 17	NUT - #10 NC hex (used prior to S/N 9685953)	2
10	195- 512	WASHER - 7/32" zinc plated	2
11	C 18153	CHANNEL - instrument panel liner	1
12	C 16362	ROD - hood hinge	1
13	132- 46	PIN - cotter 1/8" x 3/4" (used prior to S/N 9685953)	1
14	C 14500	SPACER - hood (used prior to S/N 9685953)	1
15	111- 109	BOLT - 1/4" x 1-1/4" NC round head, square neck (used prior to S/N 9685953)	1
16	131- 71	LOCKNUT - 1/4" NC hex	1
17	C 18890	PAD - foot L.H.	1
17	C 18150	PAD - foot R.H.	1
18	13- 514	BOLT - 5/16" x 7/8" NC hex	2
19	192- 20	LOCKWASHER - 5/16"	2
20	195- 104	WASHER - 3/8" flat	7
21	192- 21	LOCKWASHER - 3/8"	7
22	113- 206	BOLT - 3/8" x 3/4" NC hex	4
23	C 16239	STRAP - battery hold down	1
24	C 16373	PIN - latch	2
25	C 16374	SPRING - latch	2
26	138- 319	PIN - roll 3/16" x 1-1/4"	2
27	129- 102	NUT - 5/16" NC hex	4
28	C 16351	HINGE - frame	2
29	113- 207	BOLT - 3/8" x 1" NC hex	3
30	C 18733	PIN - attachment	2
31	131- 1318	LOCKNUT - 1/2" - 20 NF jam	2
32	C 19283	LANYARD - hood	1
33	113- 3	BOLT - 1/4" x 3/4" NC hex	2
34	192- 19	LOCKWASHER - 1/4"	2
35	129- 101	NUT - 1/4" - 20 hex	2
36	C 20082	LINER - hood	1

SEAT, FENDERS AND TOOL TRAY

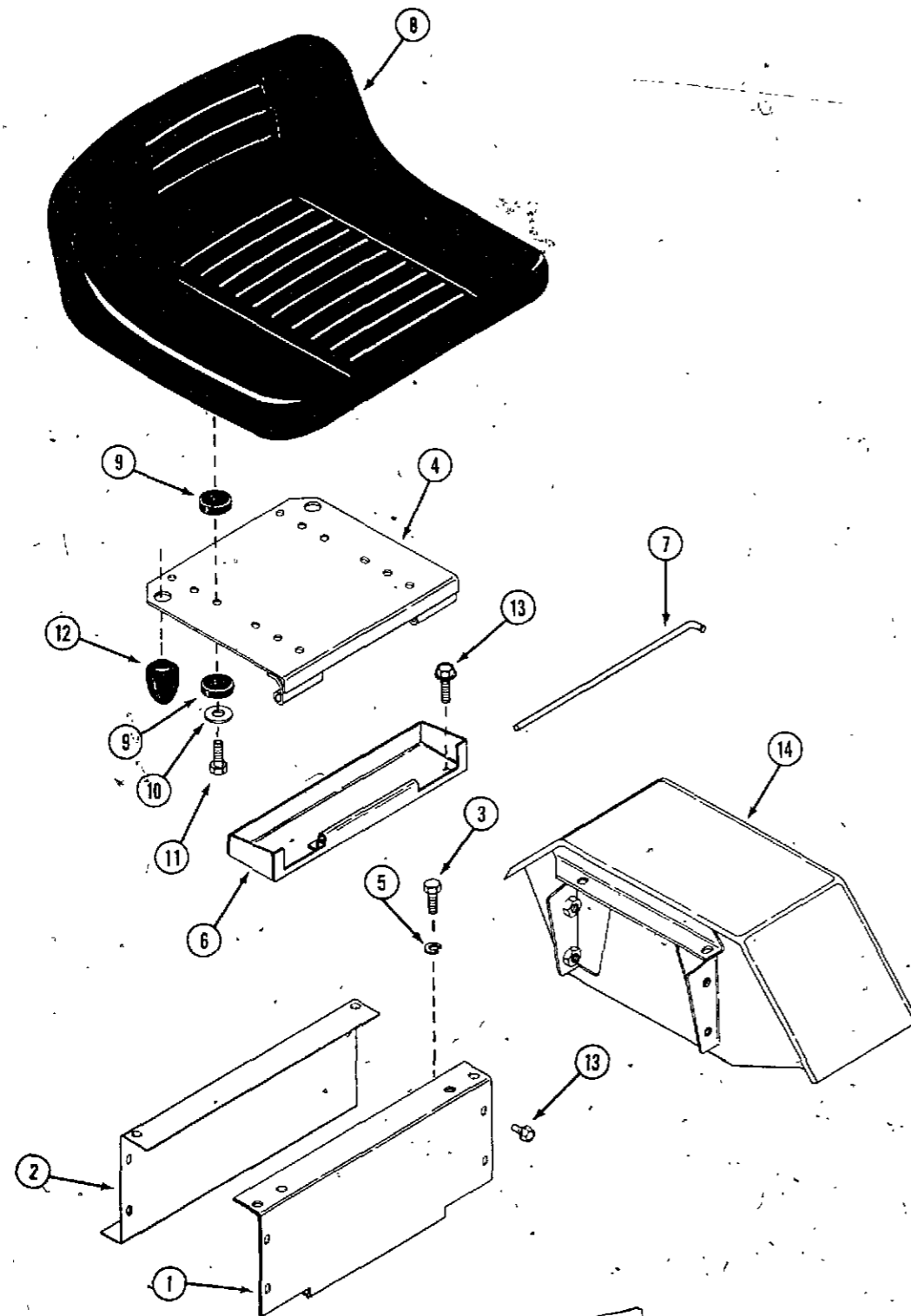

REF.	PART NO.	DESCRIPTION	REQ'D
1	C 18996	SUPPORT - seat, front	1
2	C 16404	SUPPORT - seat, rear	1
3	113- 424	BOLT - 1/2 x 1" NC hex	4
4	C 17152	HINGE ASSEMBLY - seat	1
5	192- 23	LOCKWASHER - 1/2"	4
6	C 19417	TRAY - tool	1
7	C 16429	PIN - seat hinge	1
8	C 16129	SEAT - operators	1
9	C 15410	CUSHION - rubber	8
10	195- 2021	WASHER - 5/16 x 1-1/4" OD, zinc plated	4
11	113- 122	BOLT - 5/16 x 1-1/2"	4
12	C 14534	BUMPER - seat	2
13	121- 106	BOLT - 5/16 x 1/2" flange whizlock	10
14	C 16446	FENDER - L.H.	1
14	C 16447	FENDER - R.H.	1

**FRONT AXLE**

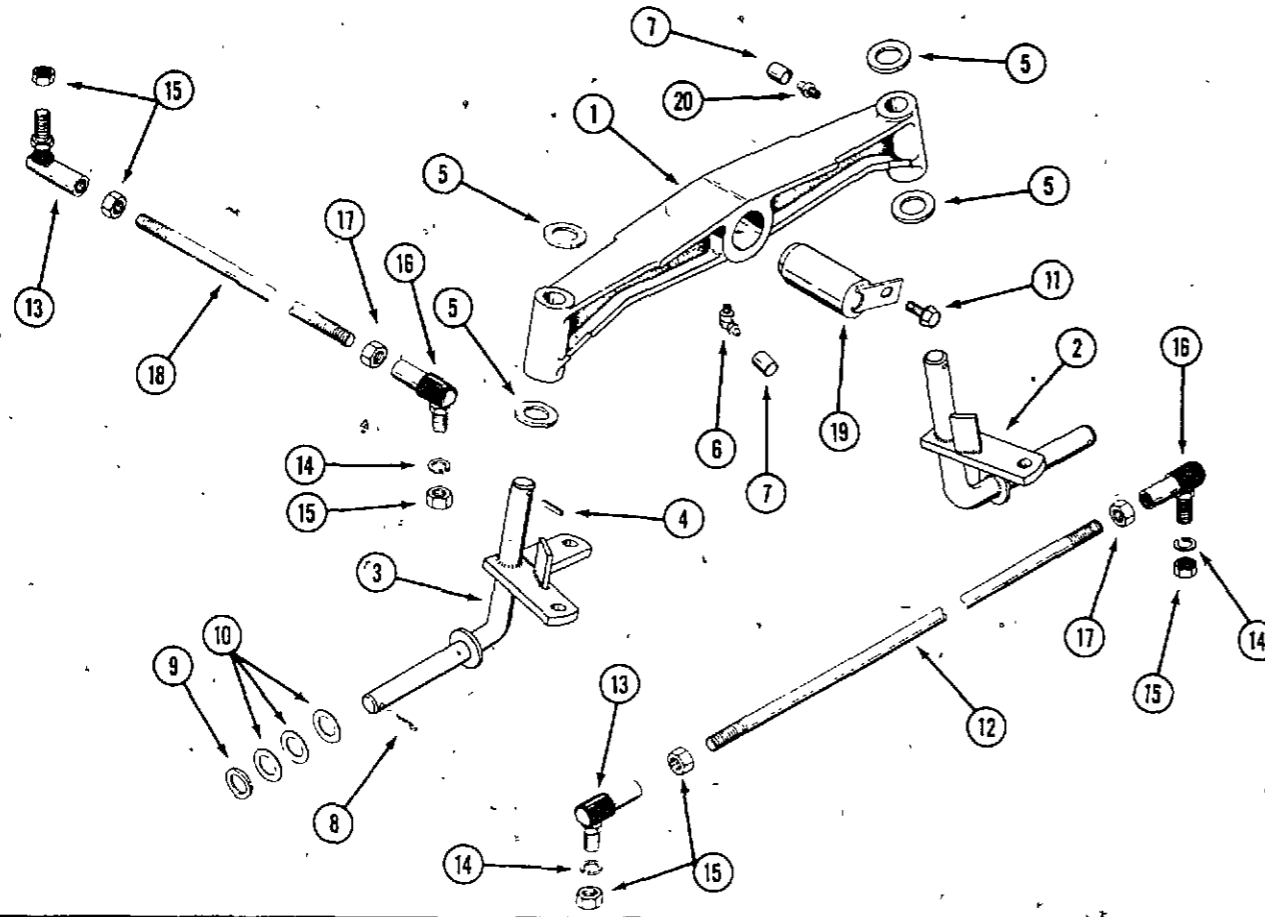

REF. PART NO.	DESCRIPTION	REQ'D
1 C 18812	AXLE - front	1
2 C 18777	SPINDLE - left hand	1
3 C 18779	SPINDLE - right hand	1
4 138- 99	PIN - roll	1
5 C 11906	WASHER - thrust	2
6 219- 404	FITTING - lube	4
7 C 13106	COVER - lube fitting	1
8 132- 311	PIN - cotter 5/32 x 1-1/4"	3
9 C 12975	WASHER - wheel spindle	2
10 A 30881	WASHER - wheel spacer	2
11 187- 1046	BOLT - 3/8" NC idented hex head	6
12 C 14334	TIE ROD	1
13 C 12102	BALL JOINT - 1/2" R.H. thread	1
14 192- 23	LOCKWASHER - 1/2" zinc plated	2
15 129- 125	NUT - 1/2" NF hex R.H. thread	3
16 C 13605	BALL JOINT - 1/2" L.H. thread	6
17 129- 325	NUT - 1/2" NF hex L.H. thread	2
18 C 18786	ROD - drag link	2
19 C 19009	PIN - axle pivot	1
20 219- 17	FITTING - lube	1

**FRONT AND REAR WHEELS**

1 C 10263	WHEEL - rear, 5 bolt	2
2 C 10314	BOLT - rear wheel	10
3 C 12081	WHEEL - front	2
4 219- 403	FITTING - lube	2
5 C 12110	BEARING - wheel, inner	2
6 C 12111	BEARING - wheel, outer	2
7 C 21682	CAP - plastic, front	2
8 A 70185	CAP - hub, rear (optional)	2
9 A 70062	CAP - hub front wheel (optional)	2

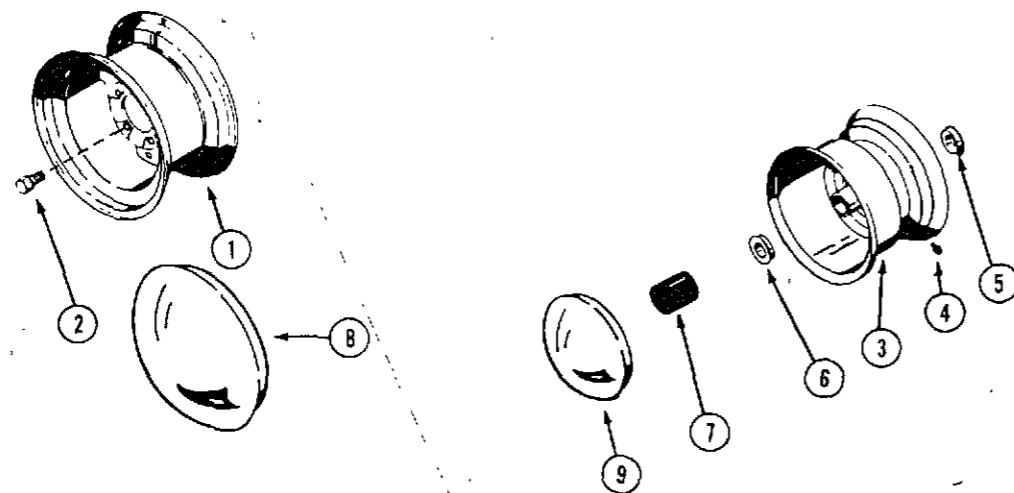

STEERING GEAR

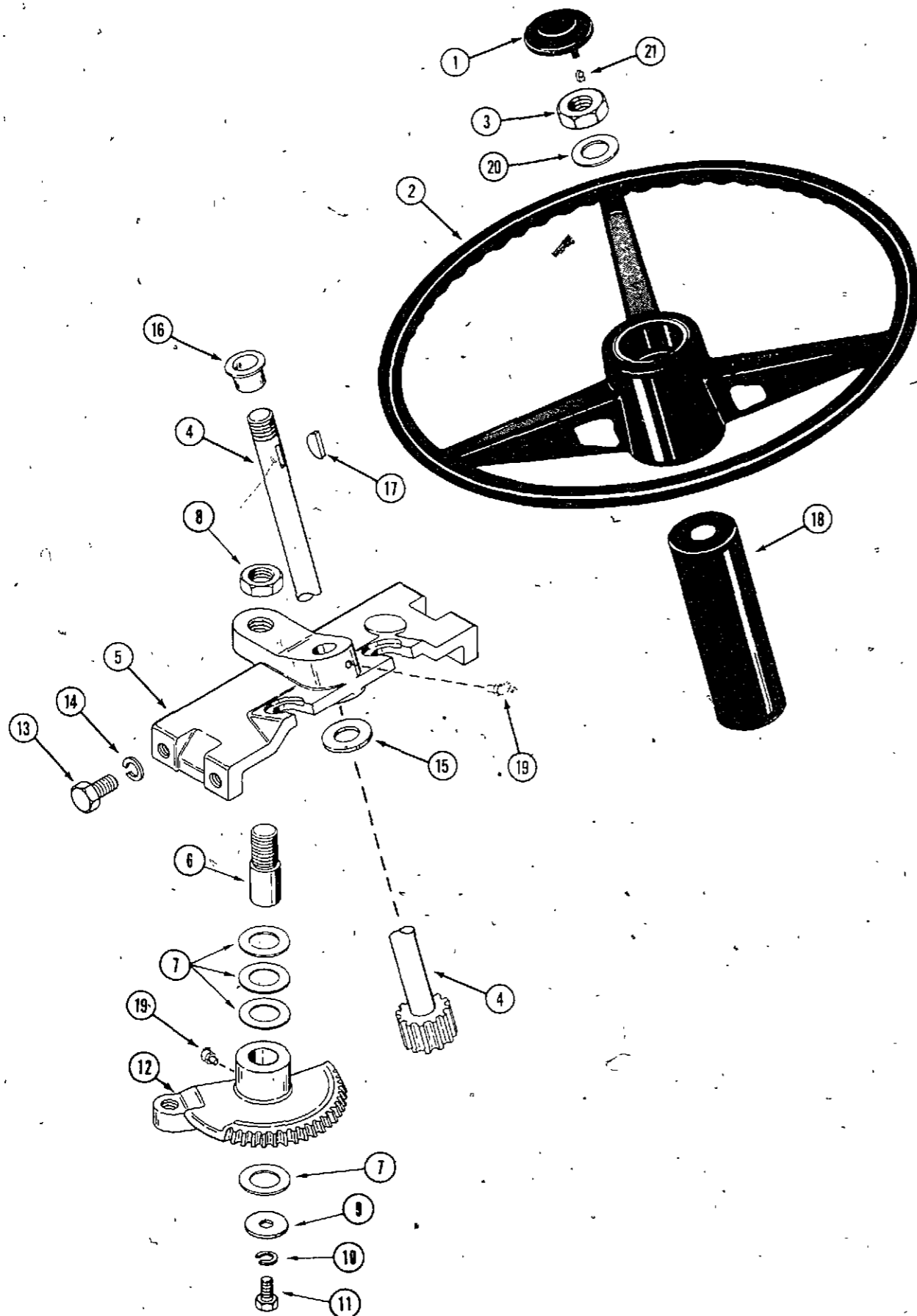

REF. PART NO.	DESCRIPTION	REQ'D
1 C 18016	CAP - steering wheel	1
2 C 18014	WHEEL - steering	1
3 131- 356	NUT - lock 5/8"	1
4 C 16200	SHAFT - steering	1
5 C 18992	SUPPORT - steering gear	1
6 C 14200	PIN - pivot	1
7 C 14201	WASHER - shim	4
8 131- 1112	NUT - jam 3/4"	1
9 195- 2021	WASHER	1
10 192- 20	LOCKWASHER - 5/16" zinc plated	1
11 113- 103	BOLT - 5/16" x 7/8" NC hex	1
12 C 18711	GEAR - steering	1
13 113- 206	BOLT - 3/8" x 3/4" NC hex	4
14 192- 21	LOCKWASHER - 3/8"	4
15 195- 2069	WASHER - 5/8" zinc plated	1
16 C 15096	BUSHING - flanged nylon	1
17 126- 16	KEY - Woodruff 3/16" x 3/4"	1
18 C 16692	TUBE - steering	1
19 219- 404	FITTING - lube 45°	2
20 C 12975	WASHER - 5/8"	2
21 C 18017	CLIP - tinnerman (use with C18014 steering wheel)	2



DRIVE PULLEYS, IDLERS AND JACKSHAFT

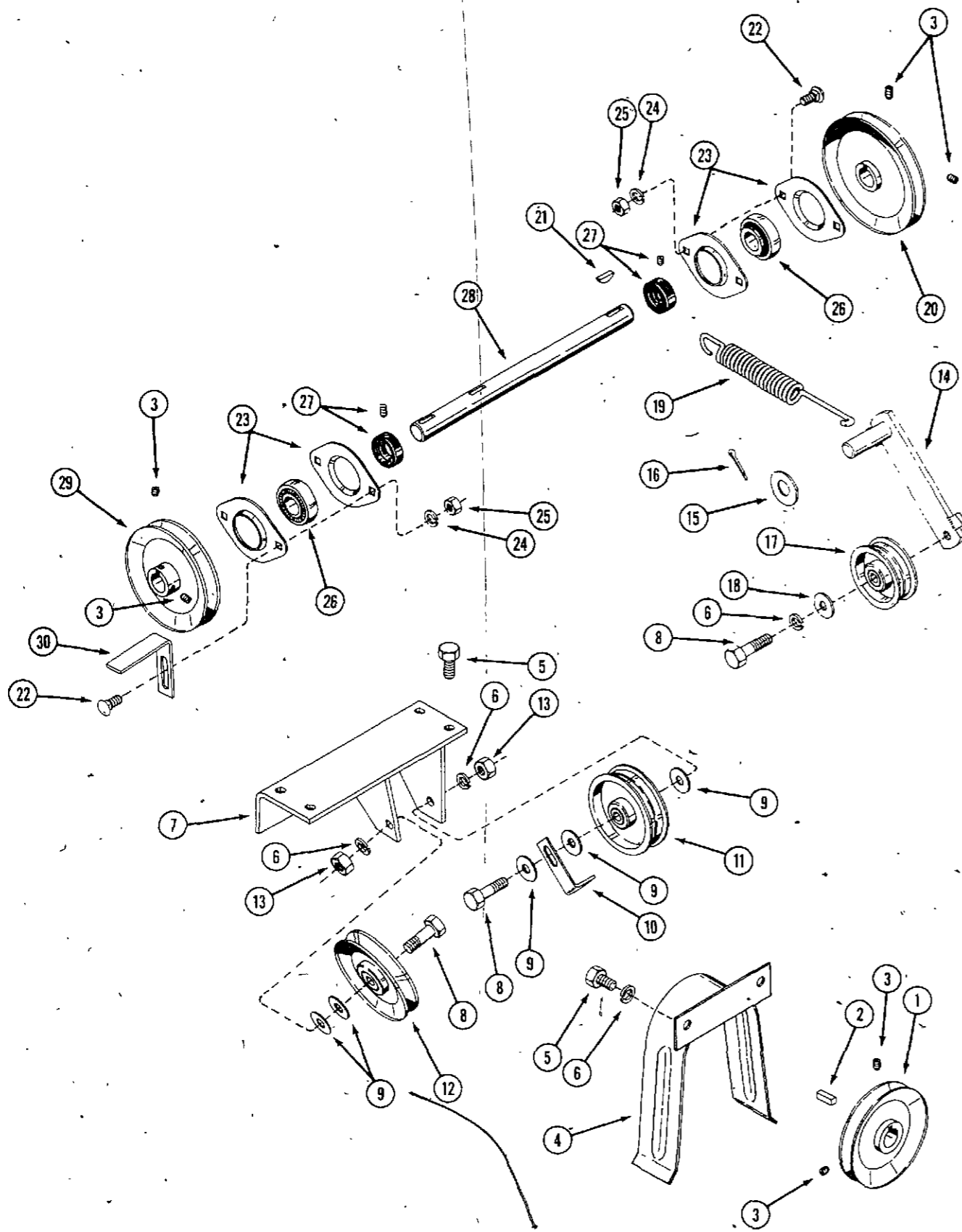

REF.	PART NO.	DESCRIPTION	REQ'D
1	C 18979	PULLEY - engine	1
2	W 5063-S	KEY - square 1/2" x 3/4"	1
3	178- 858	SETSCREW - 5/16" x 3/8"	6
4	C 19869	GUARD - belt	1
5	113- 206	BOLT - 3/8" x 3/4" NC hex	6
6	192- 21	LOCKWASHER - 3/8"	6
7	C 18974	BRACKET - drive idler mounting	1
8	113- 209	BOLT - 3/8" x 1-1/2" NC hex	3
9	195- 104	WASHER - 3/8" flat	UAR
10	C 17164	KEEPER - belt	1
11	C 18966	PULLEY - idler, flat	1
12	C 18978	PULLEY - idler V-groove	1
13	129- 103	NUT - 3/8" NC hex	2
14	C 18969	ARM - belt tension idler	1
15	195- 541	WASHER - 5/8" flat	1
16	132- 310	PIN - cotter 1/8" x 1"	1
17	C 15672	PULLEY - idler, flat	1
18	195- 104	WASHER - 3/8" flat	1
19	C 18980	SPRING - idler	1
20	C 18960	PULLEY - V-groove	1
21	126- 16	KEY - Woodruff #9	2
22	111- 202	BOLT - round head, square neck 5/16" x 3/4"	4
23	C 15514	FLANGETTE	4
24	192- 20	LOCKWASHER - 5/16"	4
25	129- 102	NUT - 5/16" NC hex	4
26	C 21681	BEARING - 3/4" bore	2
27	C 21795	LOCKING COLLAR AND SETSCREW	2
28	C 18981	JACKSHAFT	1
29	C 18968	PULLEY - V-groove	1
30	C 19688	KEEPER - belt	1

CLUTCH, BELTS AND GUARD

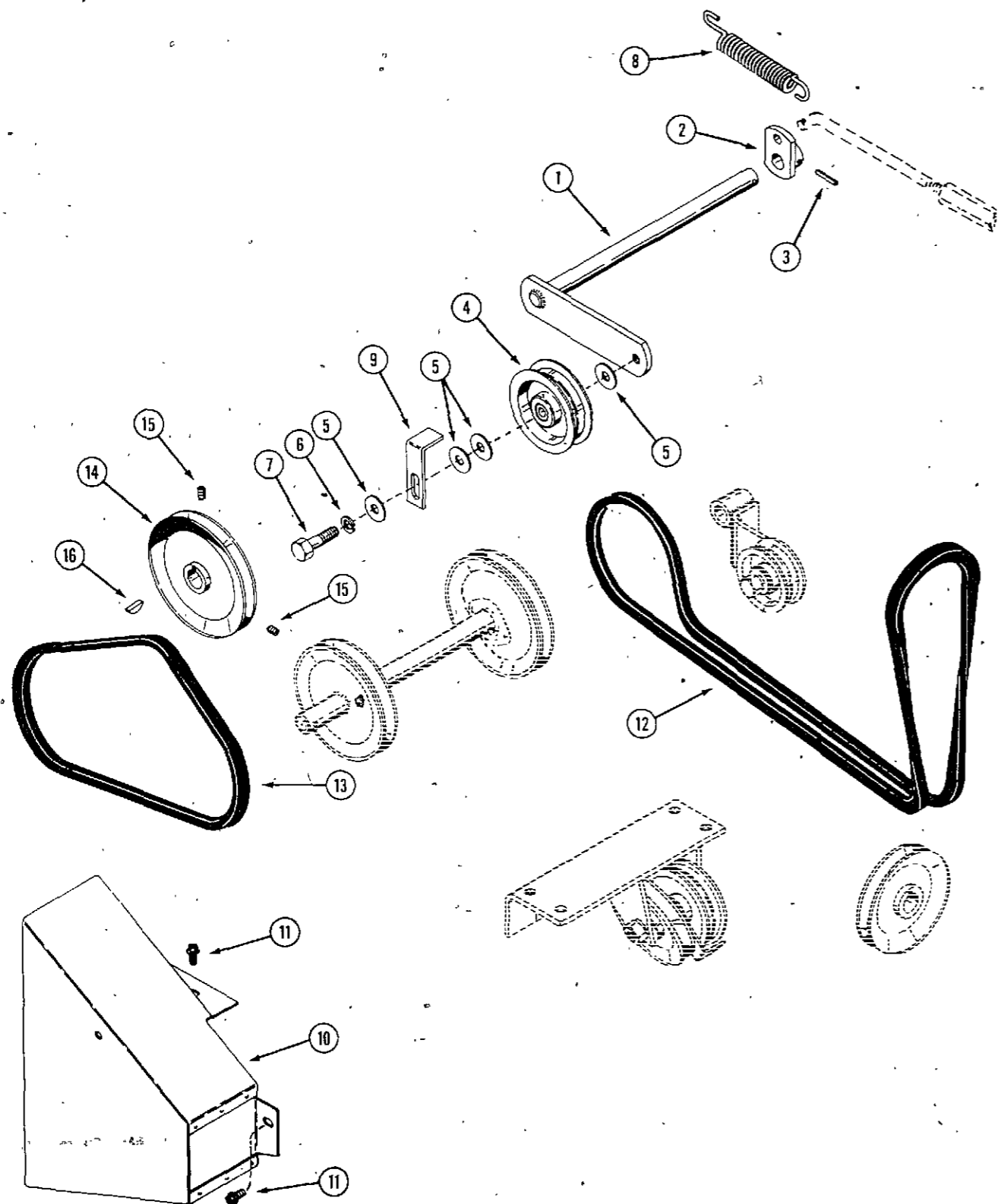

REF. PART NO.	DESCRIPTION	REQ'D
1 C 18961	SHAFT - clutch idler	1
2 C 18964	LEVER - clutch	1
3 138- 96	PIN - roll 3/16" x 1"	1
4 C 15672	PULLEY - clutch idler	1
5 195- 104	WASHER - 3/8" flat	1
6 192- 21	LOCKWASHER - 3/8"	1
7 113- 233	BOLT - 3/8" x 1-3/4" NC hex	1
8 C 19553	SPRING - clutch	1
9 C 17164	KEEPER - belt	1
10 C 19397	GUARD - belt	1
11 187- 1036	SCREW - 1/4" x 1/2" self tapping	4
12 C 18918	BELT - tractor drive	1
13 C 18919	BELT - clutching	1
14 C 18960	PULLEY - transaxle input	1
15 178- 858	SETSCREW - 5/16" x 3/8" knurled cup point	2
16 126- 16	KEY - Woodruff #9	1

**BRAKE ASSEMBLY**

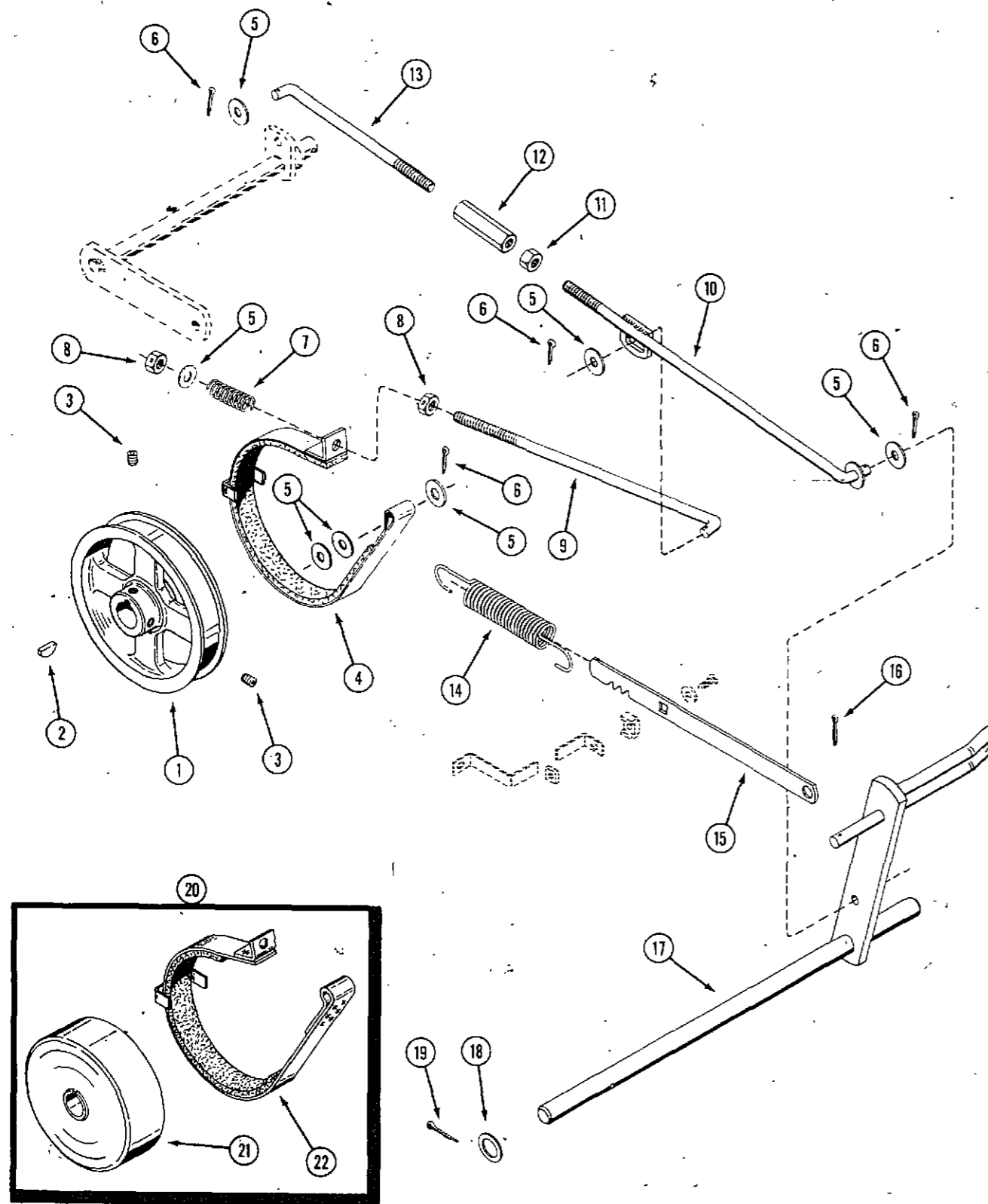

REF. PART NO.	DESCRIPTION	REQ'D
1 NSS	DRUM - brake (on transaxle) (order kit below)	1
2 126- 16	KEY - Woodruff #9	1
3 178- 858	SETSCREW - 5/16" x 3/8" knurled cup point	2
4 C 21994	BAND ASSEMBLY - brake	1
5 195- 104	WASHER - 3/8" flat	5
6 132- 46	PIN - cotter 1/8" x 3/4"	4
7 L 32763	SPRING - compression	1
8 131- 178	LOCKNUT - 3/8" NC hex	2
9 C 18988	LINK - brake	1
10 C 18985	LINK - clutch, forward	1
11 129- 103	NUT - 3/8" NC hex	1
12 C 19552	TURNBUCKLE - 3/8" hex NC	1
13 C 18986	LINK - clutch, rear	1
14 C 16379	SPRING - brake lock	1
15 C 18147	LEVER - brake lock	1
16 132- 310	PIN - cotter	1
17 C 18983	PEDAL ASSEMBLY - brake/clutch	1
18 C 12975	WASHER - brake shaft	1
19 132- 336	PIN - cotter 1/8" x 3/4"	1
20 C 22048	KIT - brake	1
21 C 21587	DRUM -	1
22 C 21584	BAND ASSEMBLY -	1

C 18956 TRANSAXLE

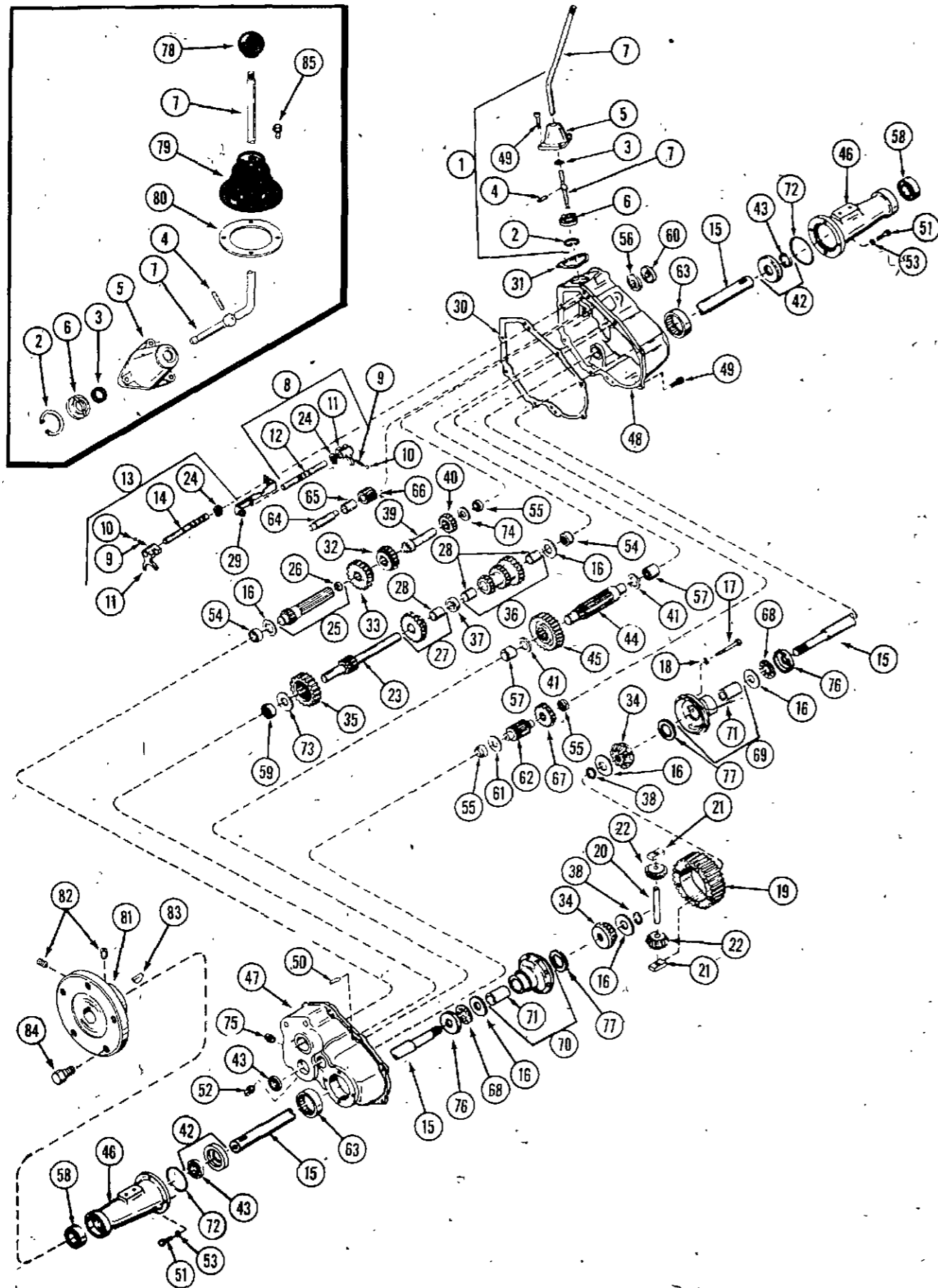

REF.	PART NO.	DESCRIPTION	REQ'D
1	C 19539	LEVER AND HOUSING ASSY. shift (Includes Ref. 2 thru 7)	1
2	C 11219	RING - snap	1
3	35012	RING - quad, shift lever	1
4	C 19324	PIN - shift lever	1
5	C 11162	HOUSING - shift lever	1
6	C 11163	KEEPER - shift lever	1
7	C 18957	LEVER - shift	1
8	C 11165	ROD ASSY. - shift (Includes Ref. 9 thru 12 and 24)	1
9	C 11166	SPRING	2
10	211- 5	BALL - steel	2
11	C 11167	FORK - shifter	2
12	C 11168	ROD - shifter (3rd and 4th)	1
13	C 11169	ROD ASSY. - shift (Includes Ref. 9, 10, 11 and 14)	1
14	C 11170	ROD - shifter (1st - 2nd and reverse)	1
15	C 11171	AXLE - transmission	2
16	C 11178	WASHER - thrust	5
17	13- 440	SCREW - 1/4" x 2-1/2" NC hex cap	8
18	92- 4	LOCKWASHER - 1/4"	8
19	C 19540	GEAR - ring	1
20	C 11173	PIN - drive	1
21	C 11174	BLOCK - drive	2
22	C 19546	PINION - bevel	2
23	C 19536	SHAFT AND GEAR - brake	1
24	A 11538	RING - snap	2
25	C 11177	SHAFT AND BEARING ASSY. - pinion	1
26	A 27287	BEARING - pinion	1
27	C 11179	GEAR ASSEMBLY - cluster	1
28	C 11180	BUSHING - cluster gear	3
29	C 11181	STOP - shifter	1
30	C 11182	GASKET - case and cover	1
31	C 11183	GASKET - shift lever housing	1
32	C 11184	GEAR - shifting (3rd and 4th)	1
33	C 11185	GEAR - shifting (1st - 2nd and reverse)	1
34	C 19547	GEAR - bevel	2
35	C 11187	GEAR - idler	1
36	C 11188	GEAR ASSEMBLY - cluster (Includes two of Ref. 28)	1
37	C 11189	SPACER	1
38	C 11222	RING - snap	2
39	C 11190	SHAFT - input	1
40	C 11191	GEAR - spur, input shaft	1
41	C 11201	WASHER - thrust	2
42	C 11192	SEAL AND RETAINER - oil (Includes ref. 45)	2
43	C 11195	SEAL - oil	3
44	C 11194	PINION - output	1
45	C 11193	GEAR - output	1

C 18956 TRANSAXLE

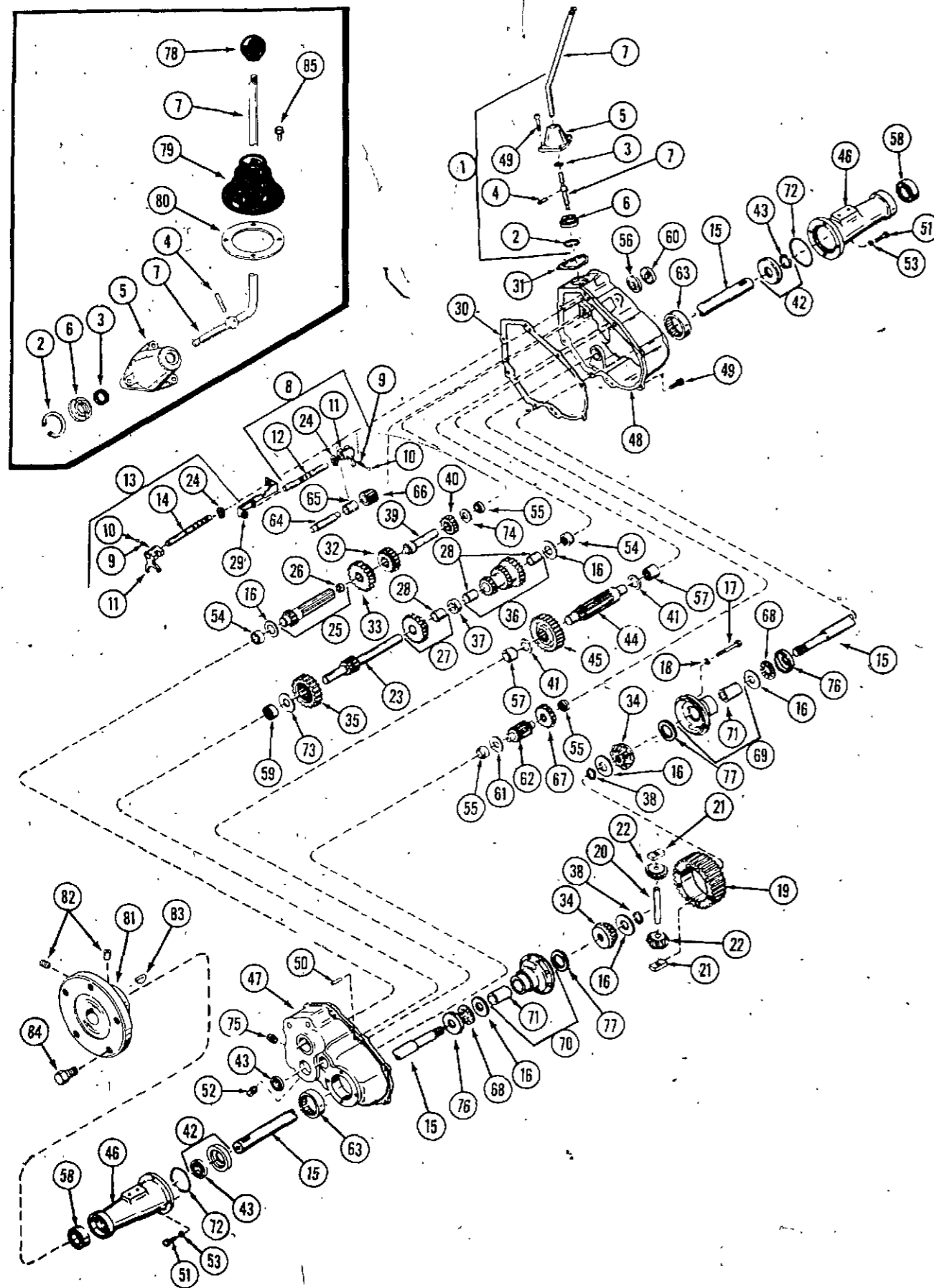

REF.	PART NO.	DESCRIPTION	REQ'D
46	C 11196	HOUSING - axle	2
47	C 19538	COVER ASSY. - transaxle (Includes ref. 54, 55, 57, 59 & 63)	1
48	C 19537	CASE ASSY. - transaxle (Includes ref. 54, 55, 57 & 63)	1
49	83- 412	SCREW - 1/4 x 3/4" NC socket head	11
50	F 53650	PIN - dowel	2
51	83- 514	SCREW - 5/16" x 7/8" NC hex	8
52	221- 672	PLUG - drain, magnetic	1
53	92- 5	LOCKWASHER - 5/16"	8
54	C 11200	BEARING - needle	2
55	A 27999	BEARING - needle	3
56	C 11202	BEARING - ball	1
57	C 11203	BEARING - needle	2
58	C 11204	BEARING - ball	2
59	A 12652	BEARING - needle	1
60	C 11206	SEAL - oil	1
61	C 11205	WASHER - thrust	1
62	C 11207	SHAFT AND PINION	1
63	R 21491	BEARING - needle	2
64	C 11209	SHAFT - idler, reverse	1
65	C 11210	SPACER - idler, reverse	1
66	C 11211	IDLER - reverse	1
67	C 11212	GEAR - spur	1
68	F 19633	BEARING - thrust	2
69	C 19541	CARRIER ASSY. - differential	1
70	C 19542	CARRIER ASSY. - differential	1
71	C 11216	BUSHING - carrier assembly	1
72	C 11208	"O" RING - axle housing	2
73	C 11223	WASHER - thrust	1
74	C 10822	WASHER - thrust	1
75	221- 13	PLUG - pipe	1
76	C 19544	RACE - thrust	2
77	C 19545	WASHER	2
78	C 10487	KNOB - shift lever	1
79	C 19448	BOOT - shift lever	1
80	C 19450	RING - boot mounting	1
81	C 10446	HUB - rear wheel	2
82	83- 68	SETSCREW - 3/8" x 1/2" NC soc.	4
83	126- 28	KEY - Woodruff #18	2
84	C 10314	BOLT - mounting, rear wheel	10
85	187- 1073	SCREW - 1/4" hex washer head - self tapping	4

**IMPLEMENT LIFT**

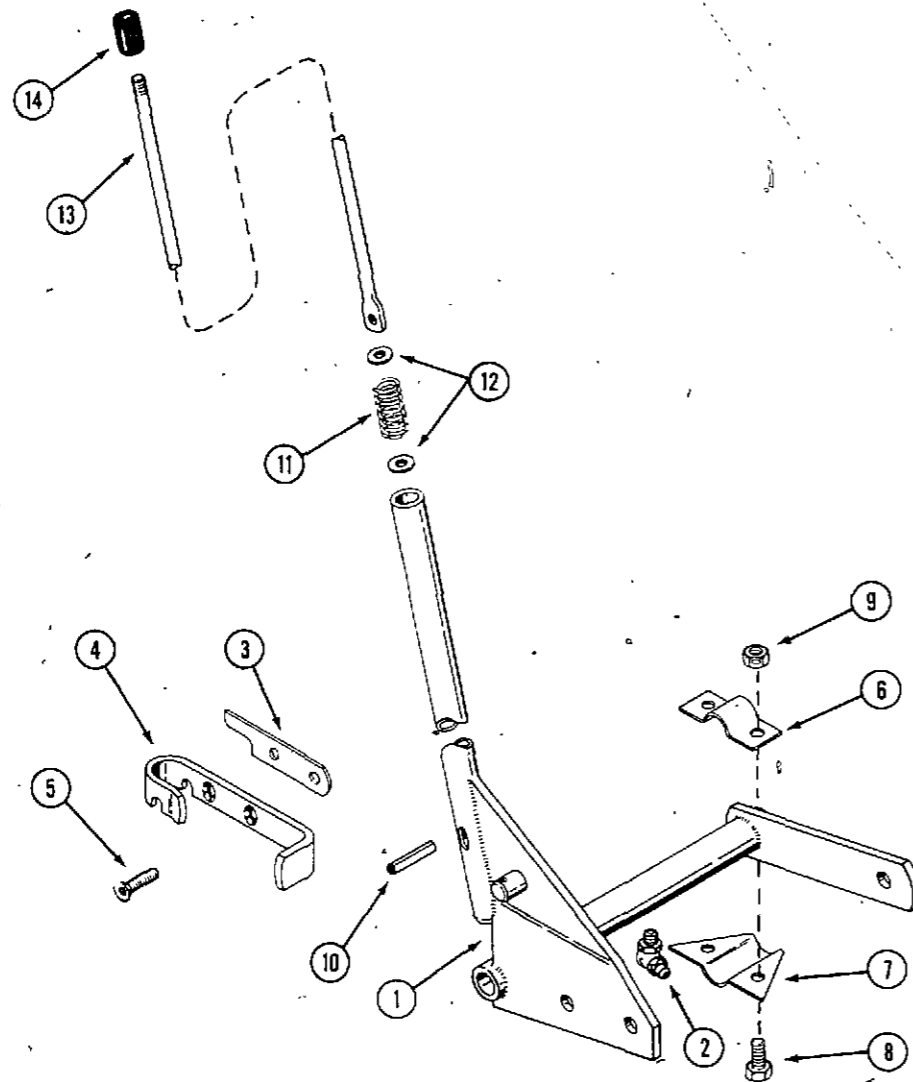

REF. PART NO.	DESCRIPTION	REQ'D
1 C 18809	LEVER ASSEMBLY - implement lift	1
2 219- 404	FITTING - lube 45°	1
3 C 17281	SPACER - latch	4
4 C 18811	LIFT - latch	1
5 164- 42	SCREW - 5/16 x 1-1/4" flat head socket	2
6 C 17249	BRACKET - mounting top	1
7 C 17250	BRACKET - mounting bottom	1
8 13- 614	BOLT - 3/8 x 7/8" NC hex	4
9 131- 178	NUT - lock 3/8"	4
10 138- 2054	PIN - spirol 5/16 x 1-3/4"	1
11 C 15564	SPRING - lift lever	1
12 195- 521	WASHER - 3/8 x 11/16" OD	2
13 C 17067	ROD - lift lever push	1
14 C 14525	BUTTON - thumb	1

**DRAWBAR AND TOW HITCH**

1 C 13360	DRAWBAR	1
2 192- 23	LOCKWASHER - 1/2" zinc plated	2
3 113- 424	BOLT - 1/2 x 1" NC hex zinc plated	2

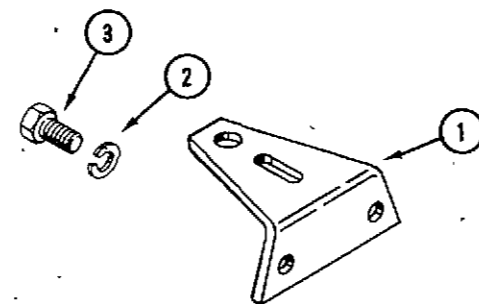

**C16852 STARTER-GENERATOR**

(DELCO NUMBER 1101875)  
(USE A 70202 FOR SERVICE)

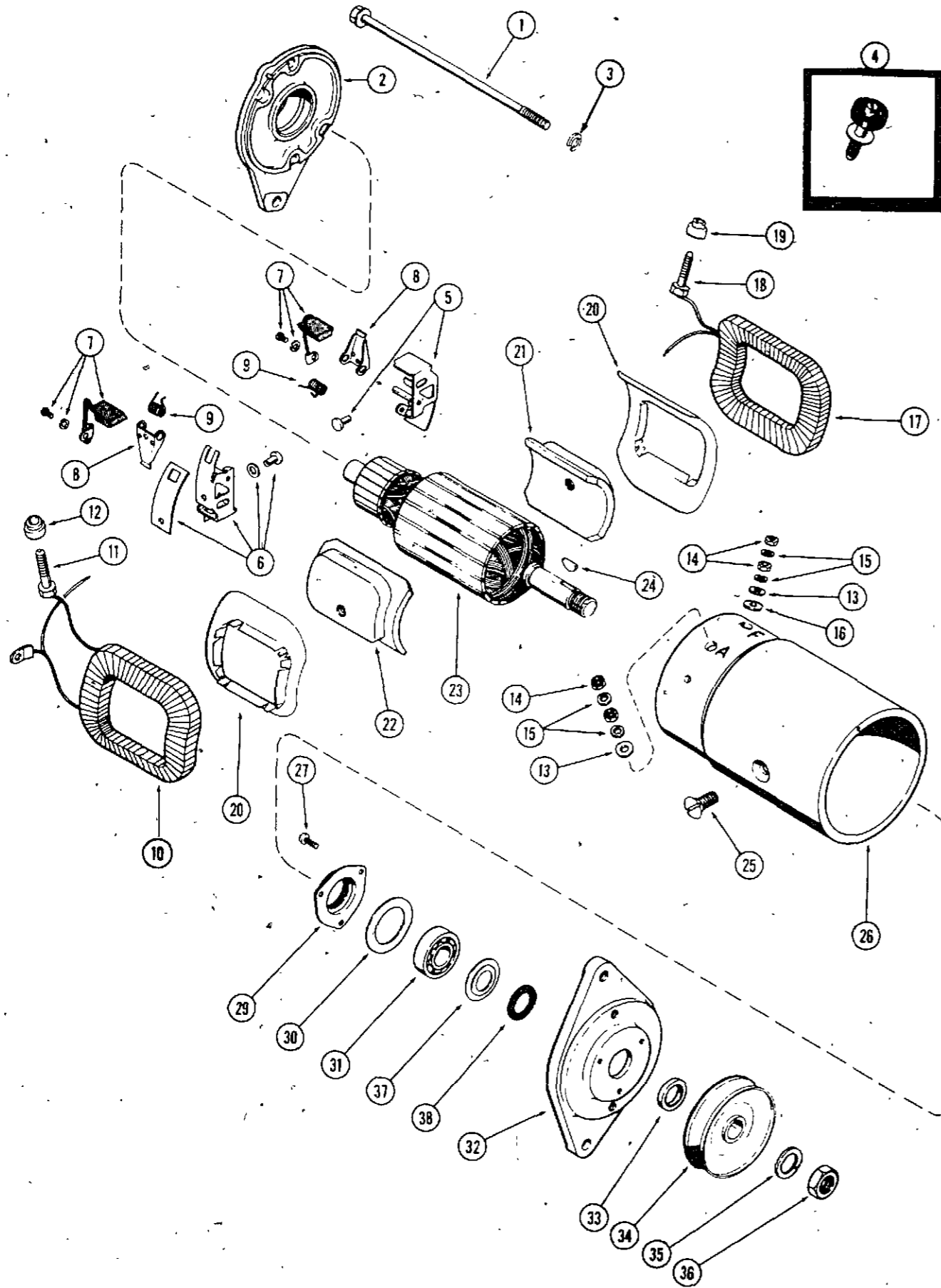

REF.	PART NO.	DESCRIPTION	REQ'D
1	R 15106	BOLT - through	2
2	A 43494	FEAME ASSEMBLY - commutator end	1
3	192- 20	LOCKWASHER - 5/16"	2
4	A 40702	KIT - stud (Includes items 16, 18 and 19)	1
5	A 72039	HOLDER KIT - ground brush	1
6	A 72040	HOLDER KIT - insulated brush	1
7	A 72038	BRUSH ASSEMBLY	2
8	R 15090	ARM - brush pressure	2
9	R 16161	SPRING - brush arm	2
10	A 72042	COIL ASSEMBLY - field R.H.	1
11	A 72048	STUD - armature terminal	1
12	R 16147	BUSHING - insulated, armature stud	1
13	A 41927	WASHER - armature stud	2
14	129- 18	NUT - terminal stud 12-24 hex	4
15	192- 17	LOCKWASHER - terminal stud #12	4
16	R 16148	WASHER - insulated, field stud (Order A40702)	1
17	A 72043	COIL ASSEMBLY - field L.H.	1
18	NSS	STUD - field terminal (Order A40702)	1
19	R 15077	BUSHING - insulated, field stud (Order A40702)	1
20	A 25447	INSULATOR - field coil	2
21	A 40736	SHOE - pole	1
22	A 40736	SHOE - pole	1
23	A 43495	ARMATURE	1
24	126- 111	KEY - Woodruff, armature	1
25	A 42127	SCREW - pole	2
26	NSS	BODY - starter, generator (Order C16852)	1
27	A 41959	SCREW - 10-32 x 1/2" round head	3
29	A 44433	RETAINER ASSEMBLY - bearing	1
*30	NSS	GASKET - ball, drive end (order A44433)	1
31	A 43356	BEARING - ball, drive end	1
32	A 72046	FRAME ASSEMBLY - drive end	1
33	A 72047	SPACER - pulley	1
34	C 14344	PULLEY - starter, generator drive	1
35	192- 116	LOCKWASHER - 11/16" plated	1
36	A 25546	NUT - armature shaft, drive end	1
37	A 43498	RETAINER - grease	1
*38	NSS	SEAL - (order A44433)	1

\*Bearing retainer gasket and felt seal not required. Order A44433 retainer assembly for servicing all starters.

**A70202 STARTER-GENERATOR**  
(DELCO NUMBER 1101970)

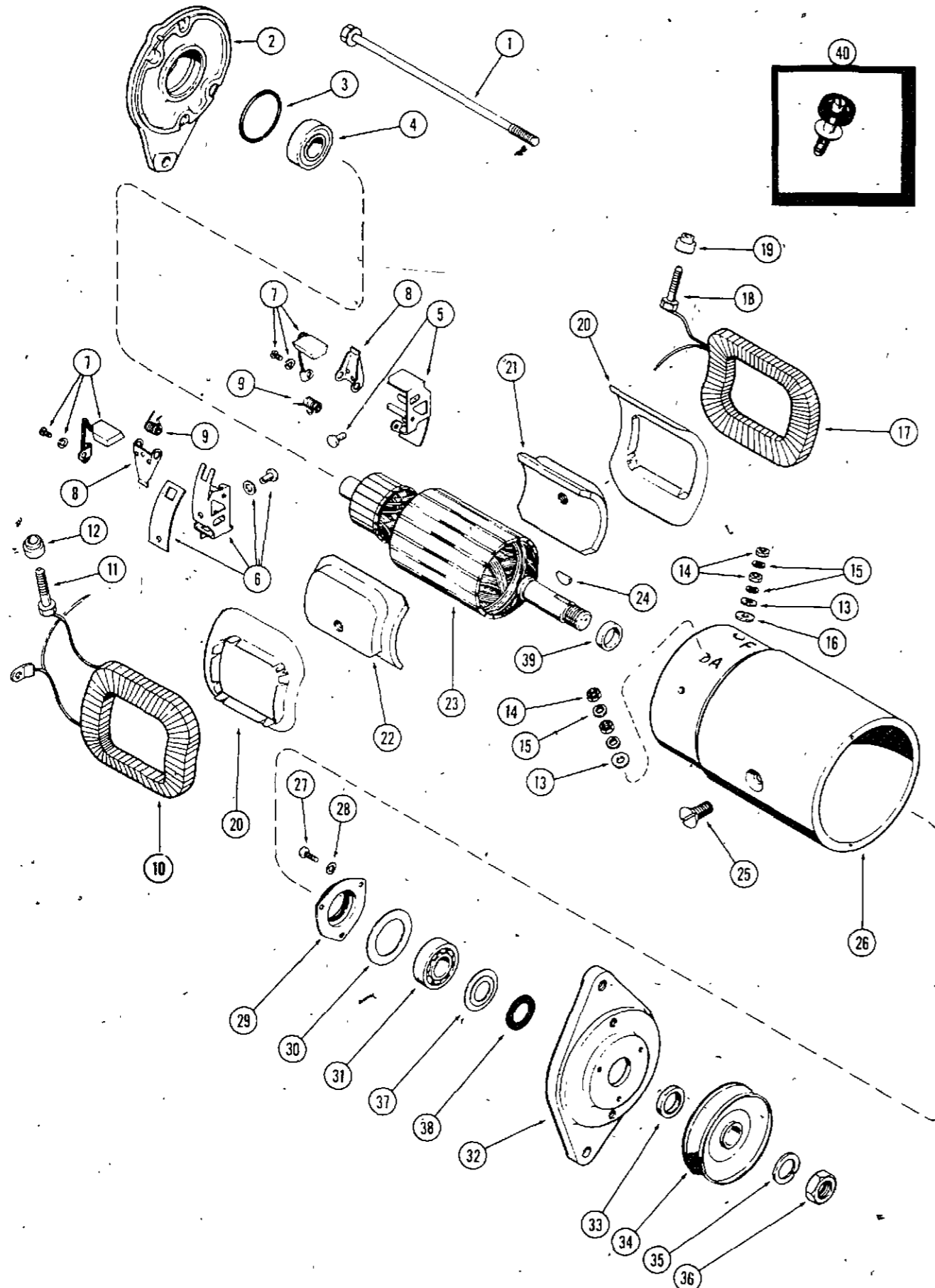

REF.	PART NO.	DESCRIPTION	REQ'D
1	R 15106	BOLT - through (Includes washer)	2
2	A 72104	FRAME ASSEMBLY - commutator end	1
3	R 15087	RING - bearing retainer	1
4	A 25461	BEARING - commutator end ball	1
5	A 72039	HOLDER KIT - ground brush	1
6	A 72040	HOLDER KIT - insulated brush	1
7	A 72038	BRUSH ASSEMBLY	2
8	R 15090	ARM - brush pressure	2
9	A 25423	SPRING - brush arm	2
10	A 72042	COIL ASSEMBLY - field R.H.	1
11	A 72048	STUD - armature terminal	1
12	R 16147	BUSHING - insulated, armature stud	1
13	R 15079	WASHER - armature stud	2
14	129- 18	NUT - terminal stud 12-24 hex	4
15	192- 17	LOCKWASHER - terminal stud #12	4
16	R 16148	WASHER - insulated, field stud	1
17	A 72043	COIL ASSEMBLY - field L.H.	1
18	NSS	STUD - field terminal (See Ref. 40)	1
19	R 15077	BUSHING - insulated, field stud (Order A40702)	1
20	A 25447	INSULATOR - field coil	2
21	A 40736	SHOE - pole, plain	1
22	A 40736	SHOE - pole, noticed	1
23	A 72041	ARMATURE	1
24	126- 111	KEY - Woodruff, armature	1
25	74- 810	SCREW - pole	2
26	NSS	BODY - starter, generator (Order A70202)	1
27	173- 237	SCREW - 10-32 x 1/2" rd. hd.	3
28	192- 18	LOCKWASHER - 3/16" plated	3
29	A 44433	RETAINER ASSEMBLY - bearing	1
*30	NSS	GASKET - bearing retainer (order A44433)	1
31	A 25441	BEARING - ball, drive end	1
32	A 72046	FRAME ASSEMBLY - drive end	1
33	A 72047	SPACER - pulley	1
34	C 14344	PULLEY - starter, generator drive	1
35	192- 26	LOCKWASHER - 11/16" plated	1
36	A 25546	NUT - armature shaft, drive end	1
37	A 43498	RETAINER - grease	1
*38	NSS	SEAL - felt (order A44433)	1
39	NSS	SPACER - armature shaft, inner	1
40	A 40702	KIT - stud (Includes items 16, 18 and 19)	1

\*Bearing retainer gasket and felt seal not required.  
Order A44433 retainer assembly for servicing all starters.



**ELECTRICAL SYSTEM**

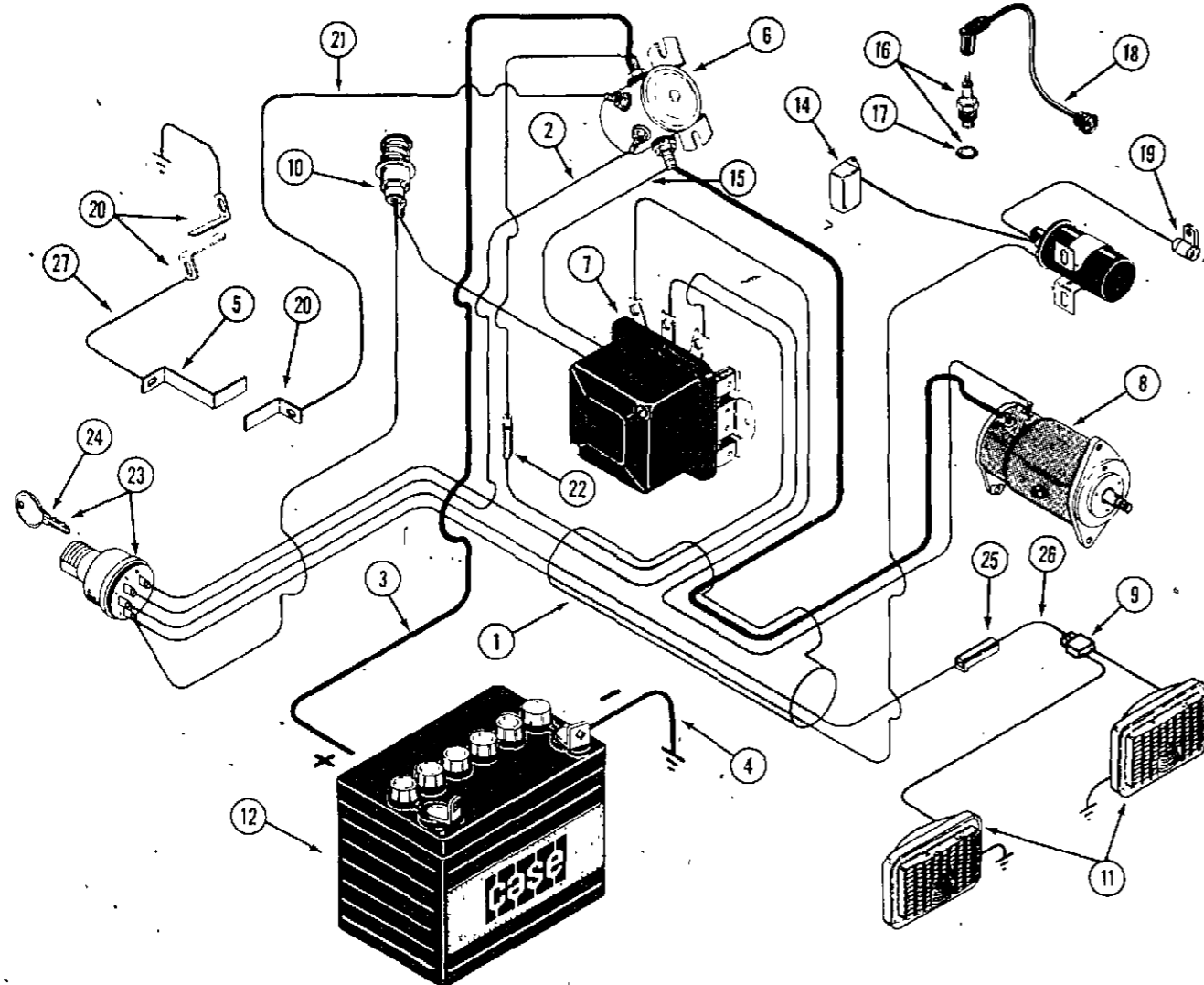

REF.	PART NO.	DESCRIPTION	REQ'D
1	C 19120	HARNES - wire	1
2	C 17187	WIRE - ignition switch to solenoid (yellow 8")	1
3	C 14565	CABLE - battery to solenoid (red 10-1/2")	1
4	C 14566	CABLE - battery to ground (black 12")	1
5	C 18998	SWITCH - strip	1
6	C 14553	SOLENOID - start	1
7	A 70221	REGULATOR - voltage, 12 volt	1
8	C 16852	STARTER - generator 12 V. (Repairs page 45) Delco No. 1101875	1
8	A 70202	STARTER - generator 12 V. (Repairs page 47) Delco No. 1101970	1
9	C 14537	CONNECTOR - headlamp	1
10	C 17186	LAMP ASSEMBLY - warning, generator indicator	1
	B 50213	BULB - generator indicator (red)	1
11	C 22571	HEADLAMP ASSEMBLY - 12 Volt (Repairs page 51)	2
12	C 18197	BATTERY - 12 volt	1
13	KO 231281	COIL - ignition 12 volt	1
14	V 34426	COVER - breaker contacts	1
15	C 17275	WIRE - regulator ground to solenoid (white 7")	1
16	M 20007	SPARK PLUG - (Includes gasket)	1
17	A 27251	GASKET - spark plug	1
18	V 34433	CABLE - high tension	1
19	KO 230722	CONDENSER	1
20	C 18115	SWITCH - strip	3
21	C 19055	WIRE - solenoid to safety switch (black 17")	1
22	223 20	FUSE - 20 amp, (used in C19120 harness)	1
23	C 21595	SWITCH - ignition	1
24	C 17763	KEY - ignition	1
25	C 19286	CONNECTOR - headlight extension	1
26	C 19287	WIRE - headlight extension	1
27	C 18203	WIRE - PTO switch to clutch switch (black 14")	1

**TAIL LAMP**

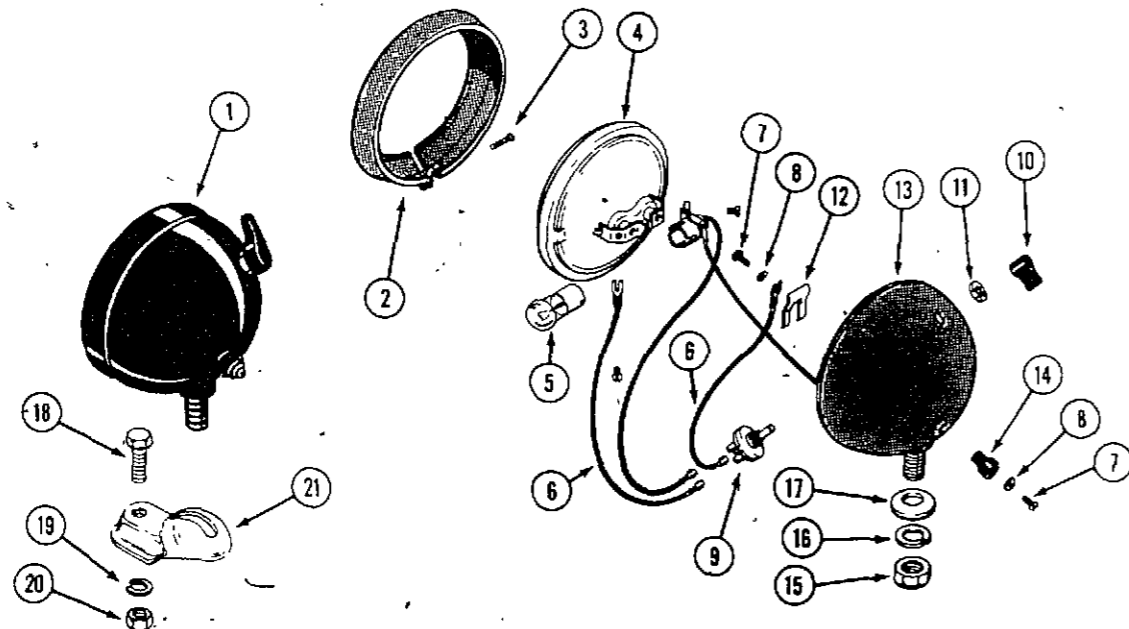

1	A 20965	LAMP ASSEMBLY - flood and tail	1
2	B 50255	MOLDING - lamp retaining	1
3	10934	SCREW - molding	1
4	A 40855	LAMP - sealed unit	1
5	B 50223	BULB - red 15 C.P. 12 volt	1
6	B 50273	WIRE - switch	2
7	173- 73	SCREW - wire	2
8	193- 4	WASHER - 1/4" lock	2
9	NSS	SWITCH - (see kit below)	1
10	NSS	KNOB - switch (see kit below)	1
11	B 50224	NUT - stitch	1
12	10927	SPRING - terminal	1
13	NSS	BODY	1
14	B 50293	TERMINAL - wire	1
15	129- 105	NUT - 1/2" NC hex	1
16	192- 23	WASHER - 1/2" lock	1
17	10923	WASHER - bearing	1
18	113- 209	BOLT - 3/8 x 1-1/2" NC hex, zinc plated	1
19	192- 21	LOCKWASHER - 3/8" zinc plated	1
20	129- 103	NUT - 3/8" NC hex, zinc plated	1
21	A 34046	BRACKET - mounting, tail lamp	1
	A 43182	KIT - switch (includes knob)	1

Printed in U.S.A.

October 1975

ELECTRICAL SYSTEM HARDWARE

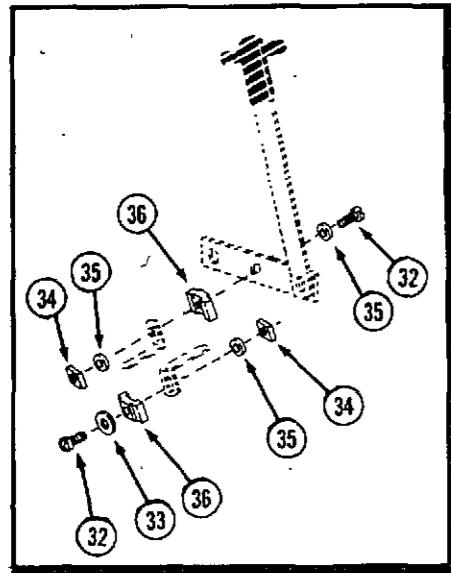

USED PRIOR TO S/N 9685953

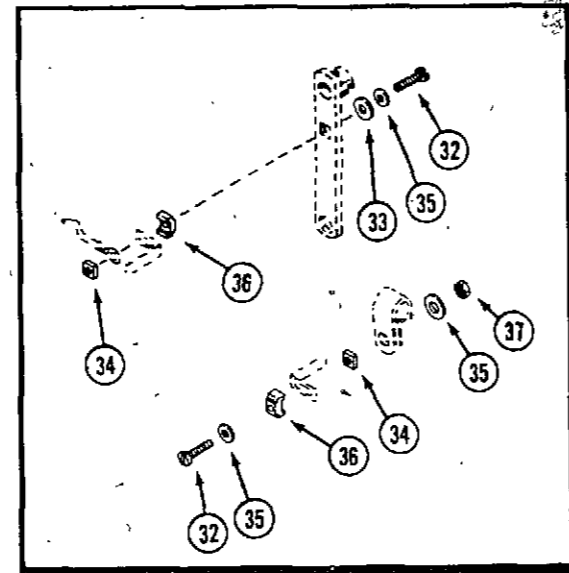

USED S/N 9685953 AND AFTER

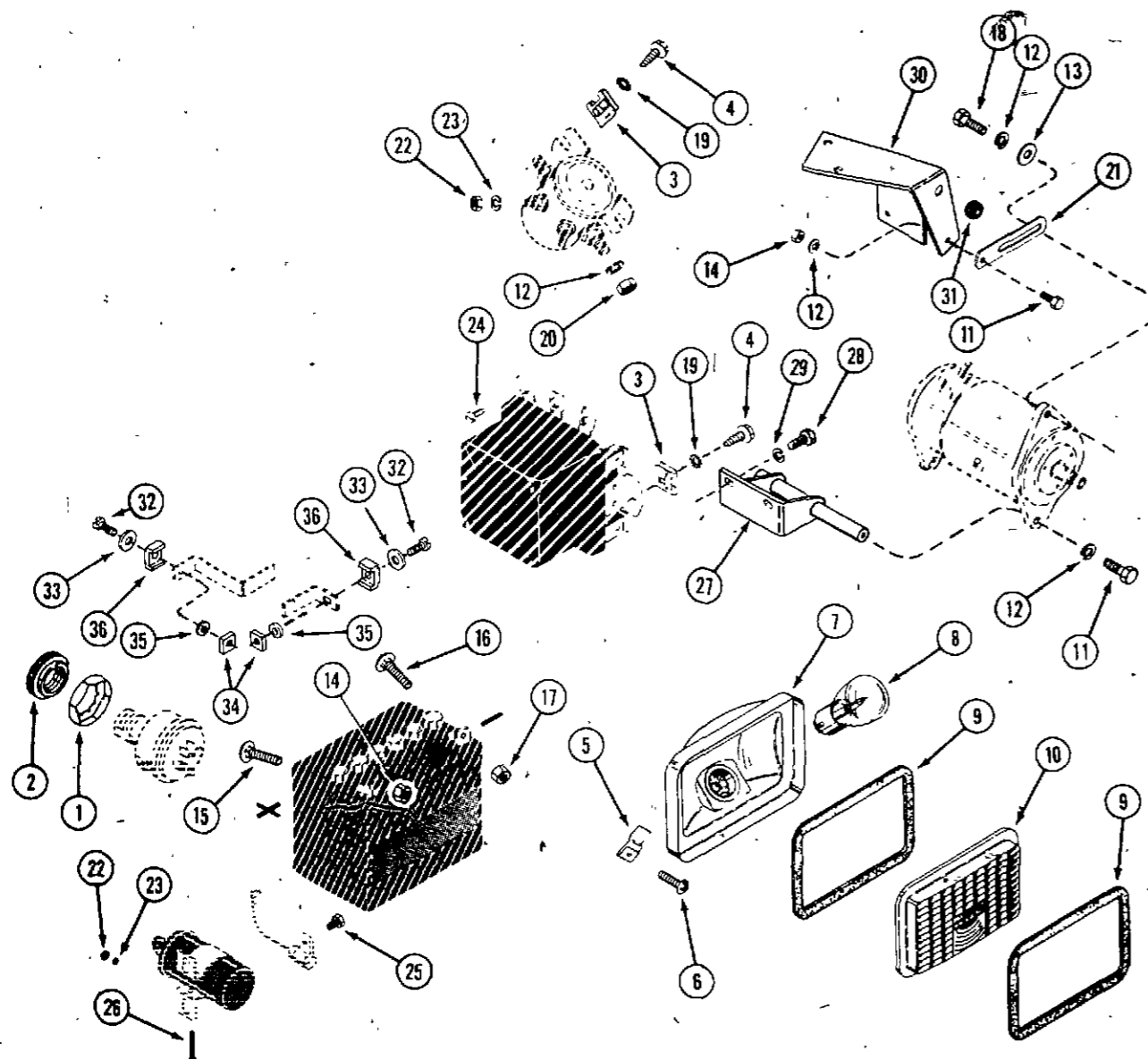

REF.	PART NO.	DESCRIPTION	REQ'D
1	C 14060	NUT - backup 3/4"	1
2	C 17921	NUT - escutcheon 3/4"	1
3	C 10836	NUT - speed type "U"	4
4	187- 485	SCREW #10 x 5/8" self-tapping hex, zinc plated	4
5	131- 629	NUT - speed type "U"	4
6	187- 1047	SCREW - #8 x 1/2" self-tapping round head, phillips	4
	C 22571	HEADLAMP ASSEMBLY	2
7	NSS	RECEPTACLE - headlamp (order C22571)	1
8	C 14305	BULB - headlamp	1
9	C 14304	GASKET - headlamp	1
10	C 22573	LENS - headlamp	2
11	113- 103	BOLT - 5/16" x 1" NC hex, zinc plated.	2
12	193- 29	LOCKWASHER - 5/16" internal tooth	5
13	195- 520	WASHER - 5/16" plain, zinc plated	2
14	129- 102	NUT - 5/16" NC hex, zinc plated	2
15	111- 202	BOLT - 5/16" x 3/4" NC, rd. hd., square neck (batt. positive)	1
16	111- 108	BOLT - 1/4" x 3/4" NC, rd. hd., square neck (batt. negative)	1
17	129- 101	NUT - 1/4" NC hex	1
18	113- 102	BOLT - 5/16" x 3/4" NC hex, zinc plated	1
19	193- 70	LOCKWASHER - # 10 external tooth	4
20	129- 122	NUT - 5/16" NF hex	2
21	C 14599	BRACKET - starter generator adjust	1
22	129- 27	NUT - # 10 NF hex	8
23	192- 18	LOCKWASHER - # 10	6
24	169- 131	SCREW - # 8 x 5/16" NC fillister head	3
25	22- 58	BOLT - 5/16" x 1/2" NC hex, self-tapping	2
26	187- 1844	SCREW - # 10 x 1-1/2" UNF self-tapping	2
27	C 18788	SUPPORT - starter generator	1
28	13- 612	BOLT - 3/8" x 3/4" NC hex	2
29	192- 21	LOCKWASHER - 3/8"	2
30	C 18999	SUPPORT - starter generator adjust	1
31	C 17546	GROMMET - wire	1
32	182- 523	SCREW - #10 x 7/8" binder head	4
33	C 19254	WASHER - nylon 13/64"	3
34	129- 77	NUT - #10-32 square	4
35	195- 513	WASHER - # 10	5
36	C 19246	HOLDER - strip switch	4
37	129- 37	NUT - # 10 - 32 hex	1
	C 19521	CLIP - wire holder	1

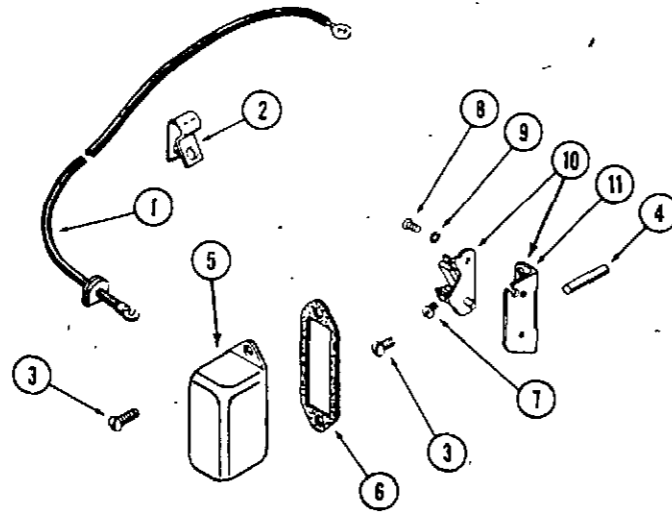

**BREAKER CONTACTS**

REF. PART NO.	DESCRIPTION	REQ'D
1 NSS	LEAD - breaker contact (Order from local supplier)	1
2 KO 275182	CLIP - wire	1
3 V 34433	SCREW - # 10 x 3/8" round head, zinc plated	4
4 V 34831	ROD - breaker contact push	1
5 V 34426	COVER - breaker contact	1
6 V 34423	GASKET - cover	1
7 187- 408	SCREW - # 6 x 3/8" self-tapping	1
8 173- 224	SCREW - # 8 x 1/4" NC round head	1
9 193- 5	LOCKWASHER - # 8 internal tooth	1
10 KOA 220474	POINT SET - breaker contact	1
11 NSS	BRACKET - breaker contact	1



**DECALS**

1	321- 2499	DECAL - hood L.H.	1
2	321- 2498	DECAL - hood R.H.	1
3	321- 2502	DECAL - instrument panel (used prior to S/N 9685953)	1
3	321- 2623	DECAL - instrument panel (used S/N 9685953 and after)	1
4	321- 1423	DECAL - "CASE" on seat back	1
5	321- 1786	DECAL - ignition switch	1
6	C 14066	DECAL - gasoline	1
7	321- 2487	DECAL - caution (used prior to S/N 9685953)	1
8	321- 2110	DECAL - parking brake	1
9	321- 2111	DECAL - attachment drive (used prior to 9685953)	1

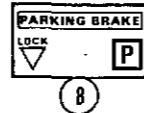
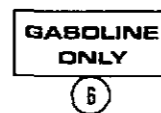
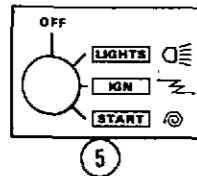
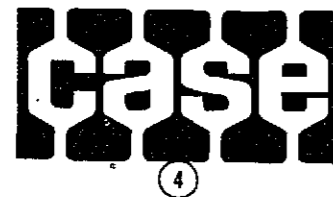
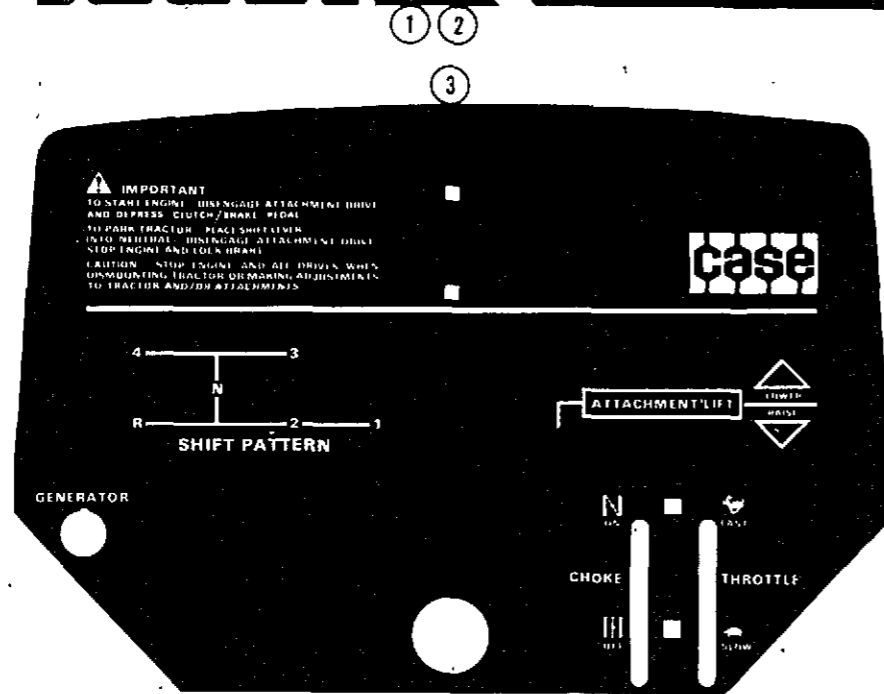

J 21 SLEEVE HITCH

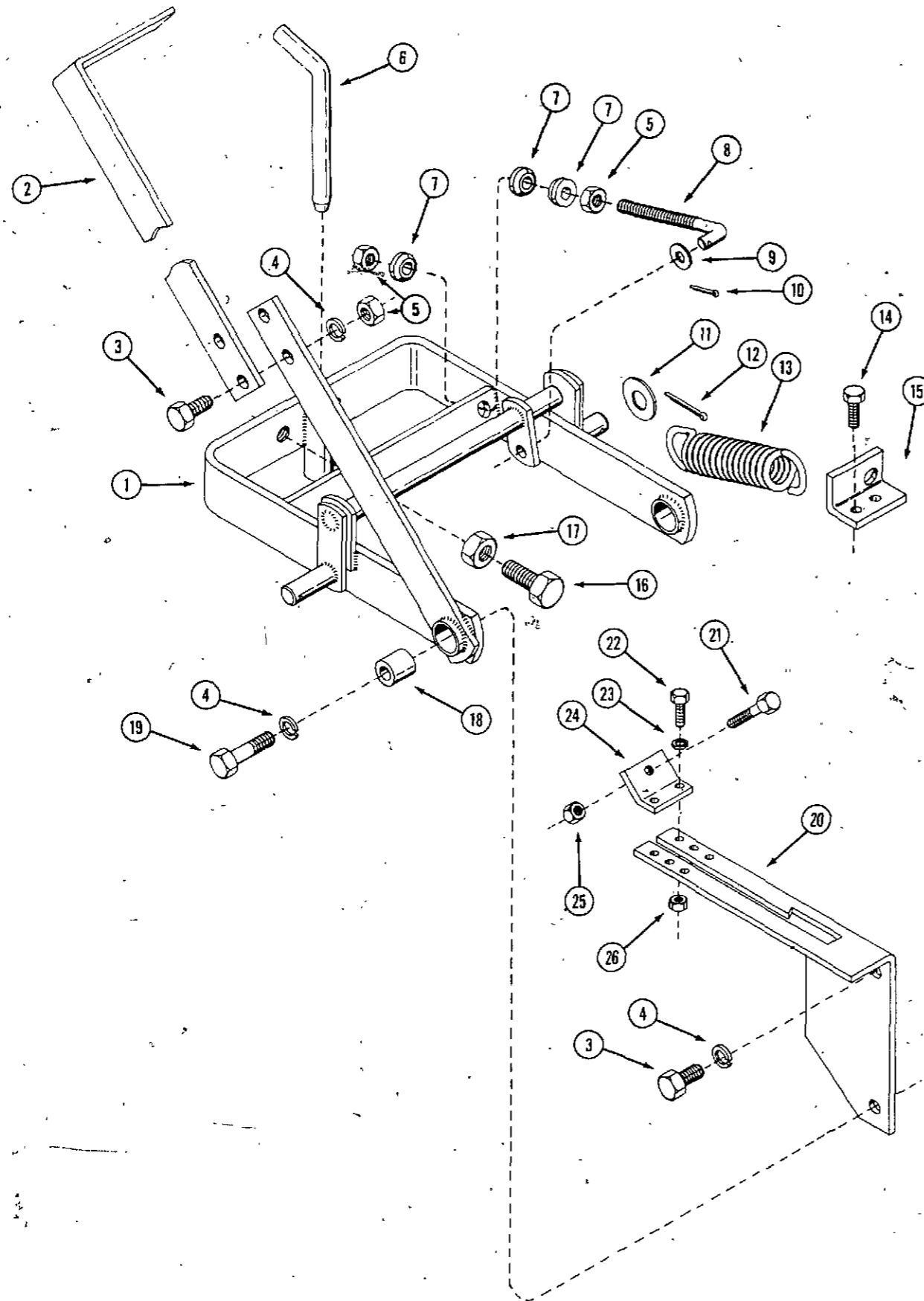

REF.	PART NO.	DESCRIPTION	REQ'D
1	C 19514	HITCH ASSEMBLY	1
2	C 19497	HANDLE - lift	1
3	113- 424	BOLT - 1/2" NC x 1" hex	3
4	192- 23	LOCKWASHER - 1/2"	3
5	129- 105	NUT - 1/2" NC hex	5
6	C 14568	PIN - drawbar	4
7	C 16097	WASHER - domed	1
8	C 19502	J-BOLT - adjusting	2
9	195- 529	WASHER - 7/16" flat	1
10	132- 48	PIN - cotter 1/8" x 1"	1
11	195- 545	WASHER - 3/4" flat	1
12	132- 306	PIN - cotter 3/16" x 1-3/4"	2
13	C 19501	SPRING - assist	2
14	113- 207	BOLT - 3/8" NC x 1" (Replaces transaxle mounting bolts when attaching spring brackets)	4
15	C 19516	BRACKET - spring attaching L.H. shown	1
	C 19517	BRACKET - spring attaching R.H. not shown	1
16	113- 607	BOLT - 5/8" NC 1-1/2" hex	2
17	129- 107	NUT - 5/8" NC hex	2
18	C 19499	SLEEVE - pivot	2
19	113- 421	BOLT - 1/2" NC x 2" hex	2
20	C 19496	LATCH - hitch	1
21	113- 257	BOLT - 3/8" NC x 2-1/2" hex	1
22	113- 103	BOLT - 5/16" NC x 1" hex	2
23	192- 20	LOCKWASHER - 5/16"	2
24	C 19498	BRACKET - lift stop	1
25	129- 103	NUT - 3/8" hex	1
26	129- 102	NUT - 5/16" hex	2

**D8 WHEEL WEIGHTS**

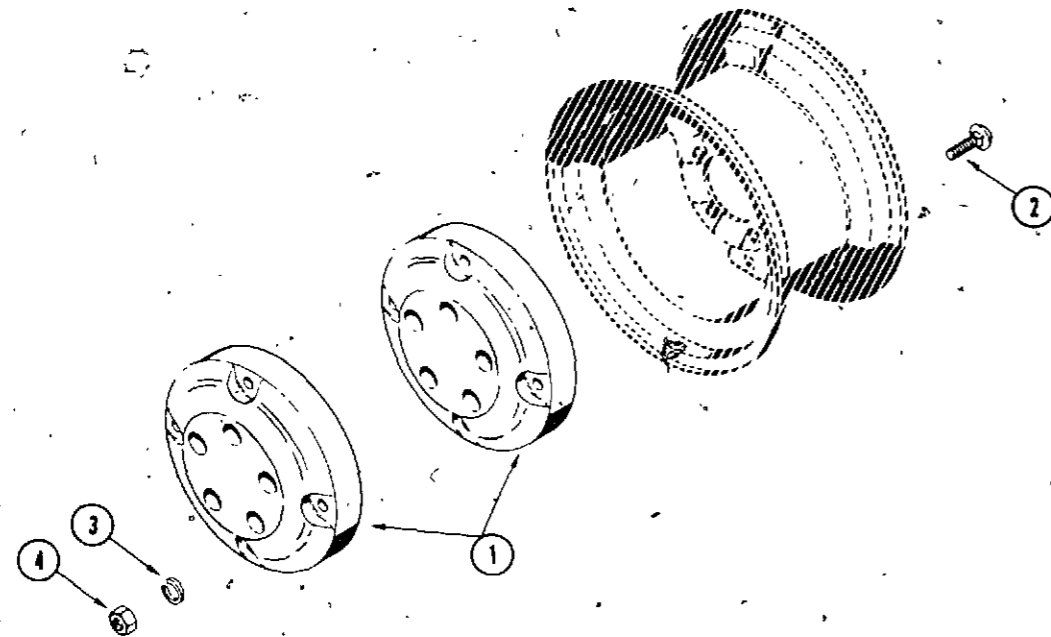

REF.	PART NO.	DESCRIPTION	REQ'D
1	NSS	WEIGHT - wheel 12" (Order as Machinery Item)	4
2	111- 532	BOLT - 1/2 x 3/4" round head, square neck, NC, zinc plated	8
3	192- 23	LOCKWASHER - 1/2" zinc plated	8
4	129- 105	NUT - 1/2" NC hex	8

**MODEL H18 FRONT END WEIGHT BRACKETS**

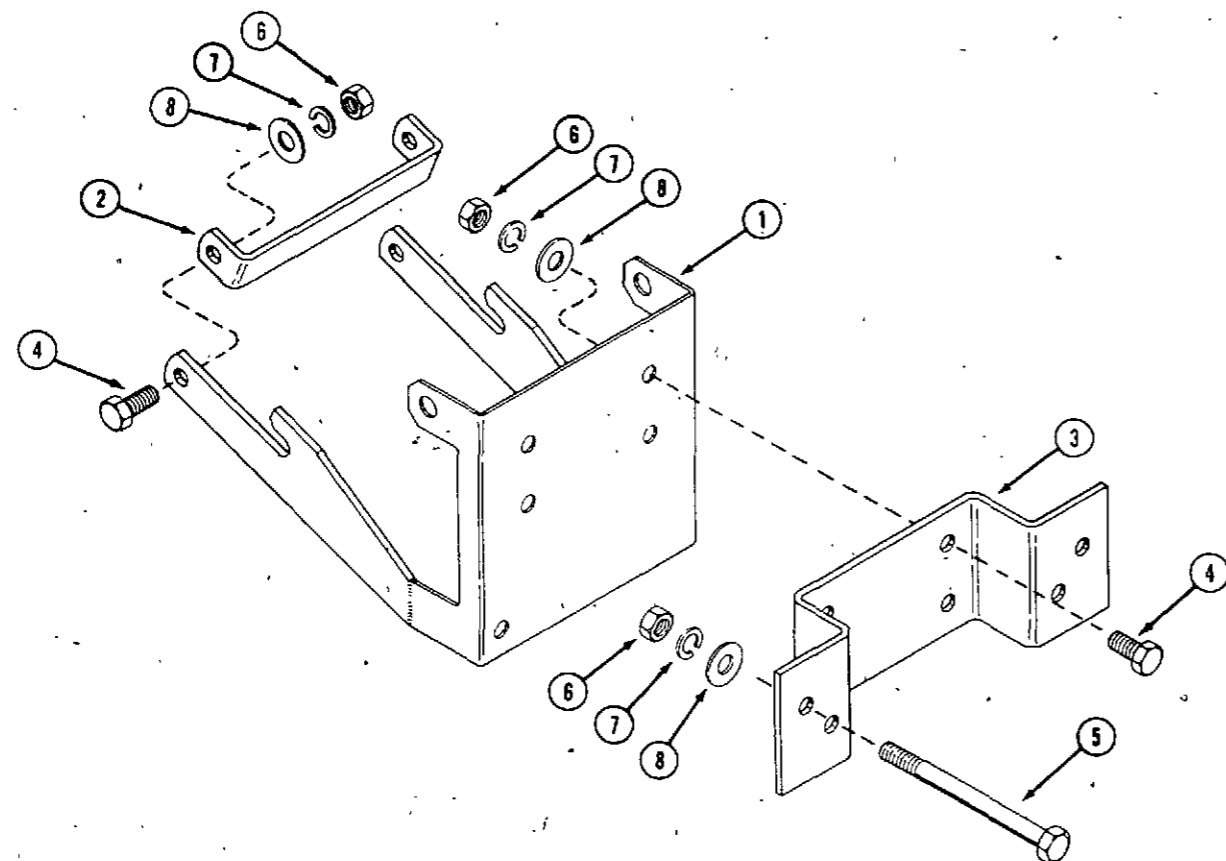

REF.	PART NO.	DESCRIPTION	REQ'D
1	C 16581	BRACKET - mounting	1
2	C 17161	BRACE - rear	1
3	C 17162	BRACKET - weight mounting	1
4	113- 417	BOLT - 1/2 x 1-1/4" NC hex, zinc plated	6
5	113- 443	BOLT - 1/2 x 6-1/2" NC hex	2
6	25- 108	NUT - 1/2" NC hex, zinc plated	8
7	192- 23	LOCKWASHER - 1/2"	8
8	195- 533	WASHER - 1/2" zinc plated	8

**MODEL H13 WEIGHT BOX**

	PART NO.	DESCRIPTION	REQ'D
1	C 17859	FRAME - weight box	1
2	C 17863	BOX - weight	1
3	C 17860	SUPPORT - weight box	1
4	C 17636	PLATE - hitch	1
5	111- 317	BOLT - 3/8 x 1" round head, square neck	3
6	113- 207	BOLT - 3/8 x 1" NC hex	4
7	129- 103	NUT - 3/8" NC hex	7
8	192- 21	LOCKWASHER - 3/8"	7
9	195- 525	WASHER - 3/8"	7

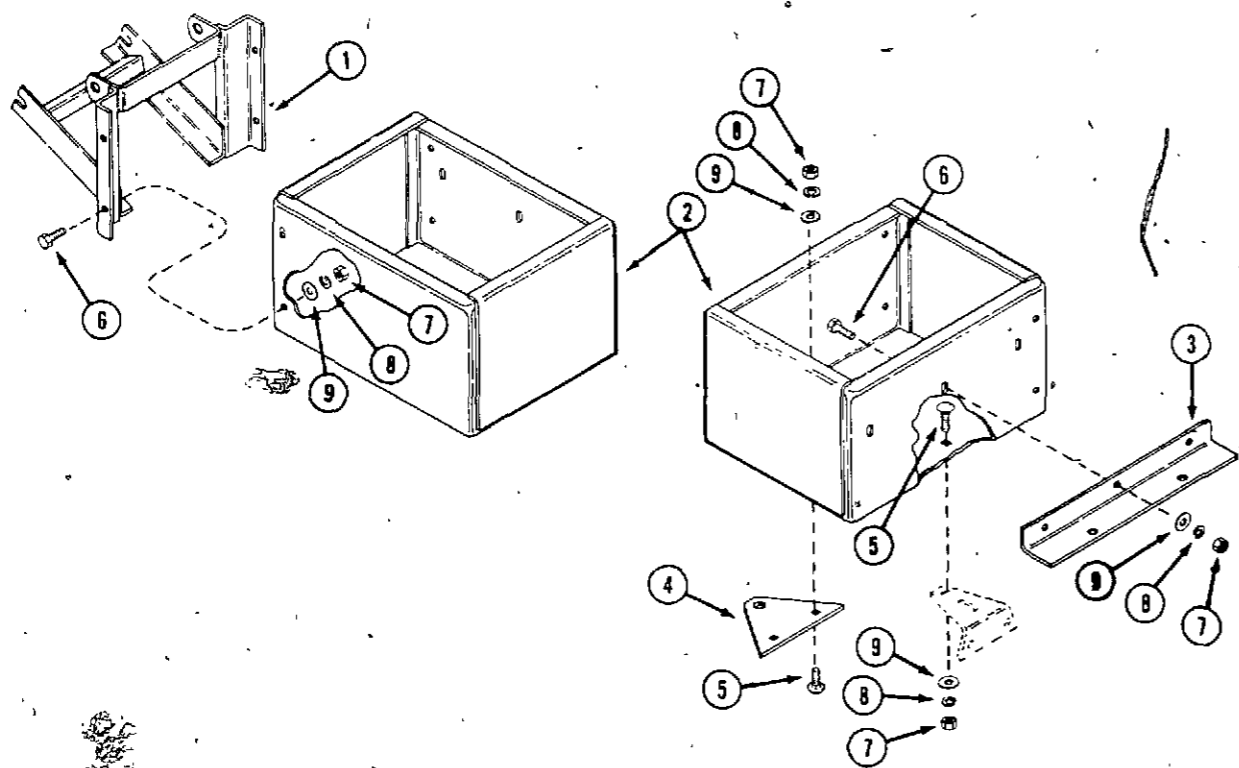

NUMERICAL INDEX

PART NO.	PAGE NO.	REF. NO.	PART NO.	PAGE NO.	REF. NO.
10923	49	17	A 72047	45	33
10927	49	12	A 72047	47	33
10934	49	3	A 72048	45	11
35012	39	3	A 72048	47	11
40035	9	20	A 72077	17	3
40035	11	28	A 72078	17	8
A 11538	39	24	A 72083	17	15
A 12652	41	59	A 72092	17	2
A 20965	49	1	A 72099	17	5
A 25423	47	9	A 72103	17	11
A 25441	47	31	A 72104	47	2
A 25447	45	20	B 50213	49	-
A 25447	47	20	B 50223	49	5
A 25461	47	4	B 50224	49	11
A 25546	45	36	B 50255	49	2
A 25546	47	36	B 50273	49	6
A 27001	9	23	B 50293	49	14
A 27251	49	17	C 10263	29	1
A 27287	39	26	C 10314	29	2
A 27365	11	39	C 10314	41	84
A 27999	41	55	C 10372	13	13
A 30881	29	10	C 10446	41	81
A 34046	49	21	C 10487	41	78
A 37247	21	1	C 10657	41	78
A 39519	21	8	C 10678	15	14
A 40702	45	4	C 10822	41	74
A 40702	47	40	C 10836	51	3
A 40736	45	21	C 11162	39	5
A 40736	45	22	C 11163	39	6
A 40736	47	21	C 11163	39	6
A 40736	47	22	C 11165	39	8
A 40855	49	4	C 11166	39	9
A 41927	45	13	C 11167	39	11
A 41959	45	27	C 11168	39	12
A 42127	45	25	C 11169	39	13
A 43182	49	-	C 11170	39	14
A 43356	45	31	C 11171	39	15
A 43494	45	2	C 11173	39	20
A 43495	45	2	C 11174	39	21
A 43495	45	23	C 11177	39	25
A 43498	45	37	C 11178	39	16
A 43498	47	37	C 11178	39	16
A 44433	45	29	C 11179	39	27
A 44433	47	29	C 11180	39	28
A 70062	29	9	C 11181	39	29
A 70090	5	5	C 11182	39	30
A 70185	29	8	C 11183	39	31
A 70202	49	8	C 11184	39	32
A 70221	49	7	C 11185	39	33
A 72038	45	7	C 11187	39	35
A 72038	47	7	C 11188	39	36
A 72039	45	5	C 11189	39	37
A 72039	47	5	C 11190	39	39
A 72040	45	6	C 11191	39	40
A 72040	47	6	C 11192	39	42
A 72041	47	23	C 11193	39	45
A 72042	45	10	C 11194	39	44
A 72042	47	10	C 11195	39	43
A 72043	45	17	C 11196	41	46
A 72043	47	17	C 11200	41	54
A 72046	45	32	C 11201	39	41
A 72046	47	32	C 11202	41	56
			C 11203	41	57
			C 11204	41	58

NUMERICAL INDEX

PART NO.	PAGE NO.	REF. NO.	PART NO.	PAGE NO.	REF. NO.
C 11205	41	61	C 15672	33	17
C 11206	41	60	C 15672	35	4
C 11207	41	62	C 15718	23	3
C 11208	41	72	C 15721	23	1
C 11209	41	64	C 16097	55	7
C 11210	41	65	C 16129	27	8
C 11211	41	66	C 16170	25	2
C 11212	41	67	C 16200	31	4
C 11216	41	71	C 16239	25	23
C 11219	39	2	C 16351	25	28
C 11222	39	38	C 16362	25	12
C 11223	41	73	C 16363	15	17
C 11529	15	18	C 16364	25	4
C 11545	15	19	C 16373	25	24
C 11906	29	5	C 16374	25	25
C 12081	29	3	C 16379	37	14
C 12102	29	13	C 16404	27	2
C 12110	29	5	C 16429	27	7
C 12111	29	6	C 16446	27	14
C 12224	19	2	C 16447	27	14
C 12975	29	9	C 16448	19	3
C 12975	31	20	C 16449	19	1
C 12975	37	18	C 16581	59	1
C 13176	29	7	C 16692	31	18
C 13360	43	1	C 16786	23	13
C 13605	29	16	C 16796	15	20
C 14060	51	1	C 16852	49	8
C 14066	53	6	C 17067	43	13
C 14157	15	15	C 17152	27	4
C 14200	31	6	C 17161	59	2
C 14201	31	7	C 17162	59	3
C 14291	23	6	C 17164	33	10
C 14304	51	9	C 17164	35	9
C 14305	51	8	C 17186	49	10
C 14334	29	12	C 17187	49	2
C 14344	45	34	C 17249	43	6
C 14344	47	34	C 17250	43	7
C 14345	15	7	C 17275	49	15
C 14399	11	26	C 17275	49	15
C 14500	25	14	C 17281	43	3
C 14506	19	4	C 17546	51	31
C 14525	43	14	C 17574	15	16
C 14534	27	12	C 17636	59	4
C 14537	49	9	C 17717	19	1
C 14553	49	6	C 17718	19	2
C 14565	49	3	C 17763	49	24
C 14566	49	4	C 17859	59	1
C 14568	55	6	C 17860	59	3
C 14599	51	21	C 17863	59	2
C 14690	15	23	C 17921	51	2
C 14906	11	44	C 18014	31	2
C 14906	21	11	C 18016	31	1
C 14953	11	38	C 18017	31	21
C 15096	31	16	C 18097	9	24
C 15183	25	5	C 18097	11	34
C 15184	25	6	C 18097	13	6
C 15410	27	9	C 18098	19	14
C 15514	33	23	C 18099	19	30
C 15515	23	7	C 18101	9	18
C 15557	23	8	C 18103	11	12
C 15564	43	11	C 18115	49	20
			C 18147	37	15
			C 18150	25	17
			C 18153	25	11
			C 18197	49	12
			C 18203	49	27
			C 18711	31	12
			C 18733	25	30
			C 18777	29	2
			C 18779	29	3
			C 18786	29	18
			C 18788	51	27
			C 18793	19	3
			C 18794	19	4
			C 18809	43	1
			C 18811	43	4
			C 18812	29	1
			C 18814	11	43
			C 18825	21	4
			C 18890	25	17
			C 18907	23	2
			C 18908	23	15
			C 18918	35	12
			C 18919	35	13
			C 18940	23	17
			C 18942	25	1
			C 18957	39	7
			C 18960	33	20
			C 18960	35	14
			C 18961	35	1
			C 18964	35	2
			C 18966	33	11
			C 18968	33	29
			C 18969	33	14
			C 18974	33	7
			C 18978	33	12
			C 18979	33	1
			C 18980	33	19
			C 18981	33	28
			C 18983	37	17
			C 18985	37	10
			C 18986	37	13
			C 18988	37	9
			C 18989	15	1
			C 18990	21	3
			C 18992	31	5
			C 18996	27	1
			C 18998	49	5
			C 18999	51	30
			C 19009	29	19
			C 19021	15	15
			C 19053	5	1
			C 19055	49	21
			C 19120	49	1
			C 19213	5	2
			C 19246	51	36
			C 19254	51	33
			C 19283	25	32
			C 19286	49	25
			C 19287	49	26
			C 19324	39	4
			C 19362	21	1
			C 19397	35	10
			C 19417	27	6
			C 19448	41	79
			C 19449	5	8
			C 19450	41	80
			C 19472	23	-
			C 19496	55	20
			C 19497	55	2
			C 19498	55	24
			C 19499	55	18
			C 19501	55	13
			C 19502	55	8
			C 19514	55	1
			C 19516	55	15
			C 19517	55	-
			C 19521	51	-
			C 19536	39	23
			C 19537	41	48
			C 19538	41	47
			C 19539	39	1
			C 19540	39	19
			C 19541	41	69
			C 19542	41	70
			C 19544	41	76
			C 19545	41	77
			C 19546	39	22
			C 19547	39	34
			C 19552	37	12
			C 19553	35	8
			C 19688	33	30
			C 19767	21	15
			C 19803	23	-
			C 19811	25	1
			C 19867	21	12
			C 19869	33	4
			C 20035	21	3
			C 20036	21	7
			C 20037	21	2
			C 20053	21	20
			C 20056	25	4
			C 20082	25	36
			C 20093	21	5
			C 20107	21	14
			C 21584	37	22
			C 21587	37	21
			C 21595	49	23
			C 21596	23	11
			C 21679	19	35
			C 21679	21	11
			C 21681	33	26
			C 21682	29	7
			C 21795	33	27
			C 21814	11	1
			C 21994	37	4
			C 22048	37	20
			C 22571	49	11
			C 22571	51	-
			C 22573	51	10
			C 22671	23	9
			C 22698	9	13
			C 22699	11	23
			C 22700	11	31
			C 22738	13	9

NUMERICAL INDEX

Table with 3 columns: PART NO., PAGE NO., REF. NO. containing numerical index data for parts 22738 through 235353.

Table with 3 columns: PART NO., PAGE NO., REF. NO. containing numerical index data for parts 15087 through 5063-S.

HARDWARE CODE NUMBERS

Table with 3 columns: PART NO., PAGE NO., REF. NO. containing hardware code numbers 13-48 through 92-6.

NUMERICAL INDEX

Table with 3 columns: PART NO., PAGE NO., REF. NO. containing numerical index data for parts 111-1 through 195-104.



## NUMERICAL INDEX

PART NO.	PAGE NO.	REF. NO.	PART NO.	PAGE NO.	REF. NO.	PART NO.	PAGE NO.	REF. NO.
195- 104	25	20						
195- 104	33	9						
195- 104	33	18						
195- 104	35	5						
195- 104	37	5						
195- 126	21	7						
195- 126	21	18						
195- 512	25	10						
195- 513	51	35						
195- 518	19	10						
195- 520	51	13						
195- 521	15	18						
195- 521	43	12						
195- 525	5	4						
195- 525	21	10						
195- 525	59	9						
195- 529	55	9						
195- 533	59	8						
195- 541	9	25						
195- 541	33	15						
195- 545	11	36						
195- 545	55	11						
195- 2021	27	10						
195- 2021	31	9						
195- 2069	31	15						
205- 27	11	30						
211- 5	39	10						
214- 251	15	4						
219- 17	29	20						
219- 403	29	4						
219- 404	29	6						
219- 404	31	19						
219- 404	43	2						
221- 13	41	75						
221- 672	41	52						
221- 1412	11	45						
223- 20	49	22						
321- 1423	53	4						
321- 1786	53	5						
321- 2110	53	8						
321- 2111	53	9						
321- 2487	53	7						
321- 2498	53	2						
321- 2499	53	1						
321- 2502	53	3						
321- 2623	53	3						
353- 442	21	13						
353- 462	21	4						

**INGERSOLL**  
Ingersoll Equipment Co., Inc.