

**CASE COMPACT TRACTORS**  
**Model 155 prior to S/N 9615882**  
**Model 195 prior to S/N 9620622**

Parts Catalog No. 989

Hi-Liter 1000 10-72

NOTE: For Models 155 & 195 after the above Serial Numbers,  
 equipped with Disk Type Brakes use Parts Catalog No. A997

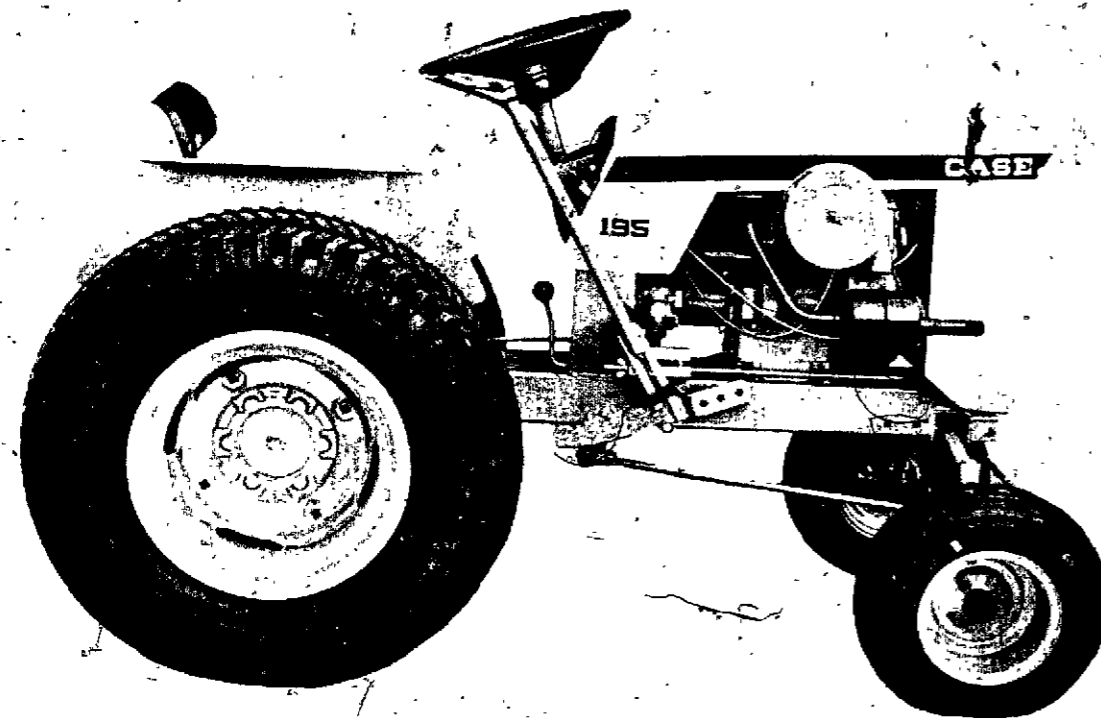
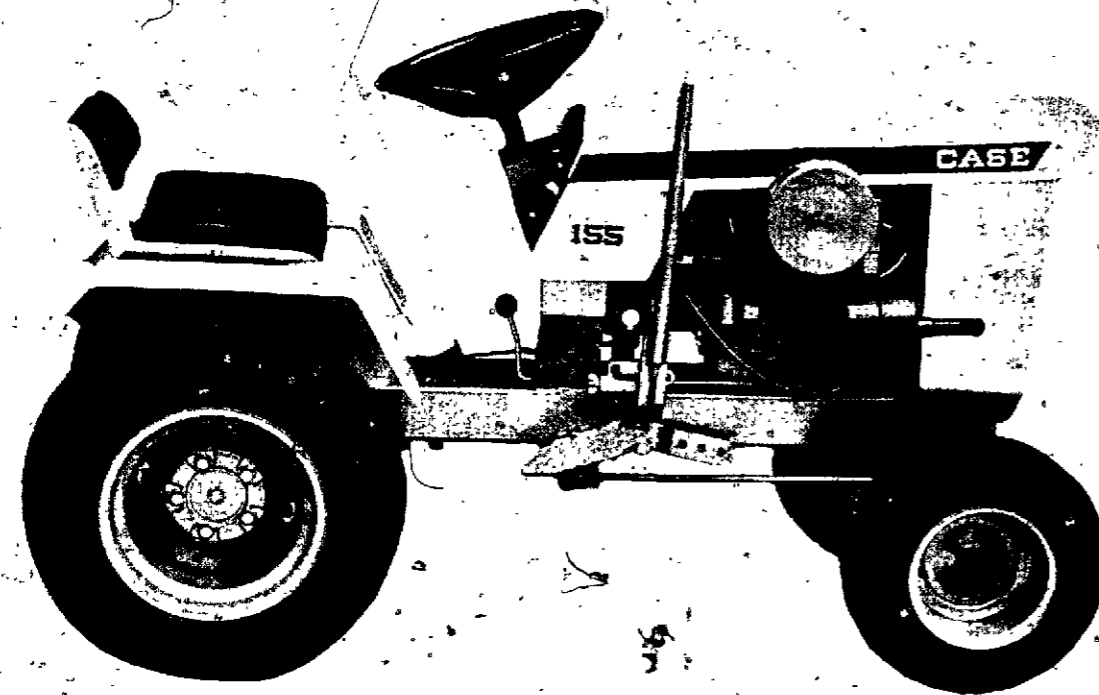

**ALPHABETICAL INDEX**

**ENGINE SECTION**

	PAGE	GRID		PAGE	GRID
Air Cleaner	5	A6	Filter, Breather	7	A8
Battery	51-53	D10-D12	Flywheel	13-15	A14-B2
Belt, Starter-Generator	25	B12	Fuel Strainer	21	B8
Breather, Crankcase	7	A8	Fuel System	19	B6
Camshaft	7	A8	Gasket Kits	13-15	A14-B2
Carburetor	21	B8	Governor	17	B4
Connecting Rod	9-11	A10-A12	Muffler	5	A6
Crankshaft	9-11	A10-A12	Oil Pan	13-15	A14-B2
Cylinder Block	13-15	A14-B2	Piston	9-11	A10-A12
Cylinder Head	13-15	A14-B2	PTG, Front	23	B10
Electrical System	51-53	D10-D12	Pulley, Clutch	23	B10
Engine Block & Attaching Parts	13-15	A14-B2	Spark Plug	51	D10
Exchanger, Heat	35	C8	Starter-Generator	25	B12
Exhaust System	5	A6	Tank, Fuel	19	B6
Fan	17	B4	Throttle Linkage	17	B4
			Valves	7	A8

**BASIC TRACTOR SECTION**

	PAGE	GRID		PAGE	GRID
Axle, Front	29	C2	Hydraulics (Continued)		
Rear	33	C6	Motor, Hydraulic Drive	41	C14
Baffles & Shrouds	17	B4	Pump	39	C12
Décalcs	43	D2	Valve, Control	37	C10
Fenders	43	D2	Valve, Control Linkage	37	C10
Frame	45	D4	Implement Lift Lever	47	D6
Grille	45	D4	Instruments	51-53	D10-D12
Headlights	51	D10	Seat, Operator's	43	D2
Hitch	47	D6	Steering Wheel & Gear	27	B14
Hood	45	D4	Tool Box	43	D2
Hydraulics	35-41	C8-C14	Transmission	33	C6
Coupling, Pump Drive	39	C12	Wheels, Front & Rear	31	C4
Hoses, Lines & Fittings	35	C8	Wheel Weights	55	D14

# GENERAL INFORMATION

Parts Catalog No. 989

## Indexes

This Parts Catalog is arranged for easy identification of Genuine CASE Service Parts. An alphabetical index is provided at the front of this Catalog to locate the major groups or assemblies. A numerical index at the rear of the Catalog gives the part numbers and the pages on which they are described.

## Illustrations

All parts are illustrated in "Exploded Views" which show the individual parts in their normal relationship to each other. Reference numbers are used in the illustrations. These numbers correspond to those in the "Reference Number" column and are followed by the part number, description and quantity required.

## Indented Description

Indented parts in the descriptive list are a part of the preceding assembly or sub-assembly. The quantity shown in the "Number Required" column is the number of parts used on a machine except where parts are indented in descriptive list. In this case the quantity shown is the number required for the preceding assembly or sub-assembly.

REF.	PART NO.	DESCRIPTION	REQ'D
	A 55159	CYLINDER ASSY - rear steering	1
28	A 56208	SOCKET ASSY - rear cylinder	1
29	A 55956	PLUG - adjusting, socket assy	1
30	A 55957	SEAT - socket ball	2
31	A 56210	SPRING - socket	1
32	A 56209	SEAT - socket spring	1
33	G 45175	CLAMP ASSY - socket assy	1
	16- 836	BOLT - 1/2" x 2-1/4" N.F. hex.	1
34	132- 104	PIN - cotter, 3/16" x 3"	1
35	A 55889	STUD - ball, socket & cylinder	2
36	13- 410	BOLT - 1/4" x 5/8" N.C., hex.	4
37	92- 4	LOCKWASHER - 1/4" SAE	4

## Terms "Right Hand" and "Left Hand"

"Right Hand" and "Left Hand" sides of this machine are determined by standing at the rear of the unit and facing in the direction of forward travel.

## Orders

Orders should plainly specify correct part number, full description, quantity required, machine model and engine model, machine and engine serial numbers, method of shipment and shipping address.

## Changes

When changes to the machine make it necessary, revised pages for this book will be issued. The revised pages will be issued with the same page number as those they replace and the "issue" number and date will be advanced.

It is imperative that revised Parts Book pages be inserted into their respective Parts Books as soon as received. Failure to do so will lead to confusion and defeat the purpose of the book.

## CASE 155 AND 195 GARDEN TRACTORS

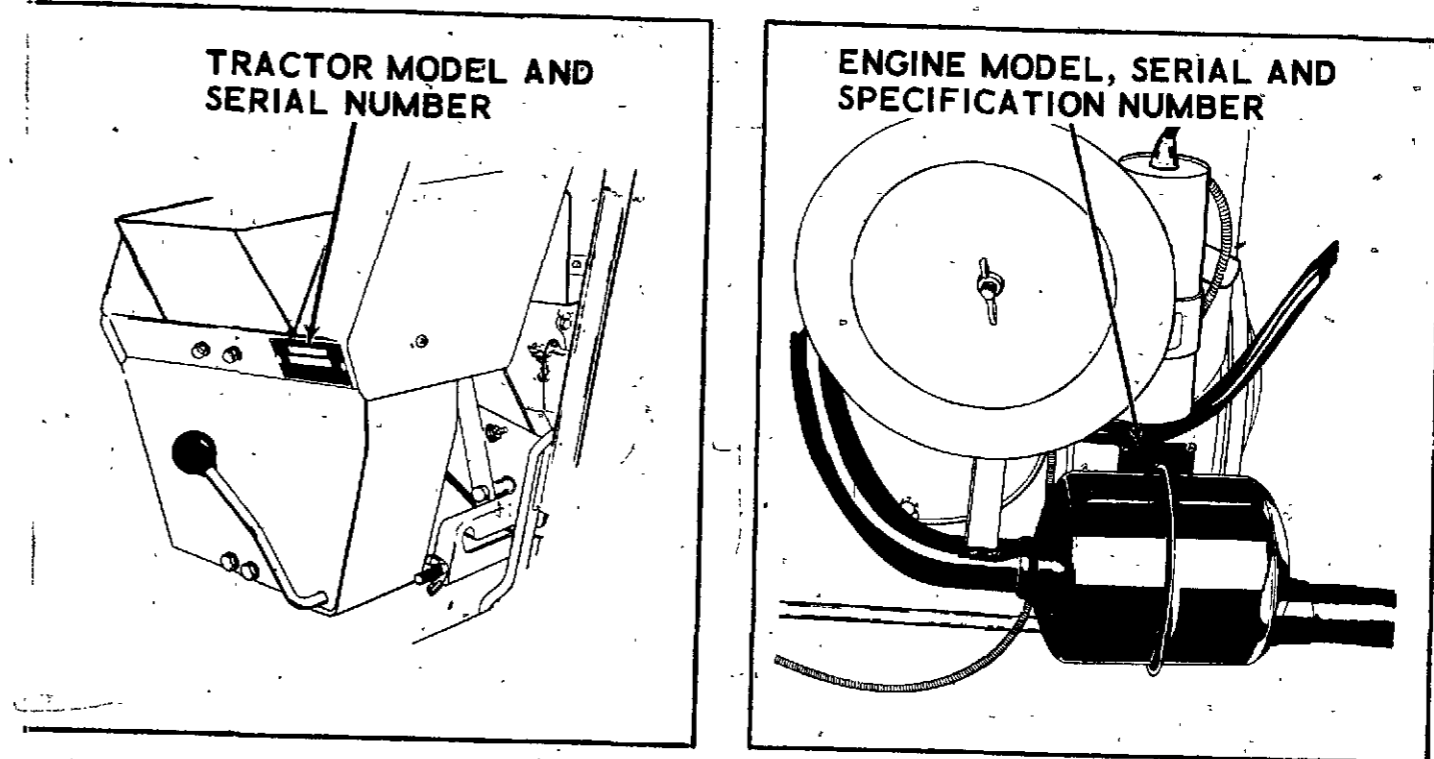

TRACTOR MODEL DESIGNATIONS	ENGINE MODEL DESIGNATIONS
155 TRACTOR	K241 A Engine
195 TRACTOR	K301 A Engine

## Serial Numbers

When using this catalog, notice the reference to serial numbers of various components noted here and listed in the "description" copy. By referring to correct serial numbers, proper parts identification will be assured.

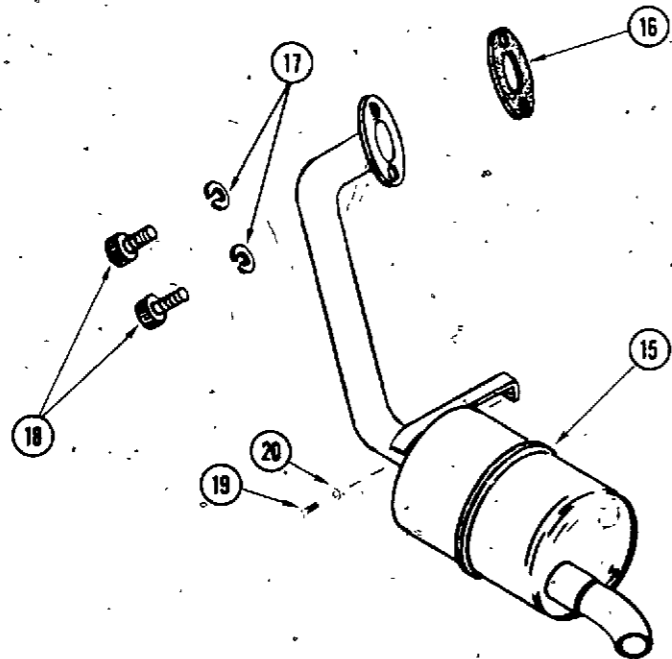
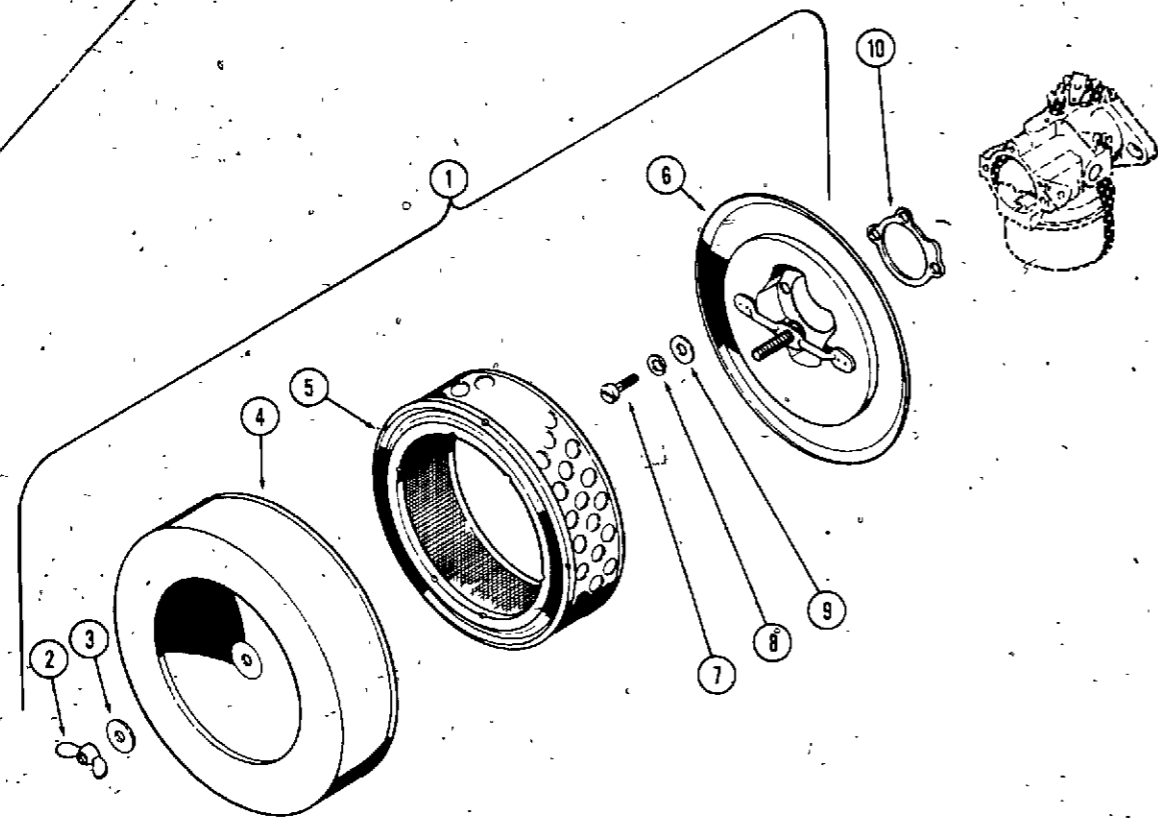

**AIR CLEANER**

REF. PART NO.	DESCRIPTION	REQ'D
1 KOA235100	AIR CLEANER ASSY	1
2 129- 409	NUT - wing, 3/8" N.C.	1
3 KOA 536	WASHER - copper	1
4 NSS	COVER - air cleaner	1
5 A 70090	ELEMENT - air cleaner	1
6 NSS	BASE - air cleaner	1
7 177- 131	SCREW - fill. hd. 10-32 x 1/2"	3
8 192- 18	LOCKWASHER - 3/16"	3
9 195- 512	WASHER - plain, 3/16" SAE	3
10 KO 275341	GASKET - air horn	1

**EXHAUST SYSTEM**

15 C 12071	MUFFLER - exhaust	1
16 C 10372	GASKET - exhaust pad	1
17 92- 5	WASHER - lock, 5/16" SAE	2
18 61- 510	SCREW - 5/16-18 x 5/8" socket hd.	2
19 71- 410	SCREW - 1/4" x 5/8" N.C., fillister head	1
20 193- 60	LOCKWASHER - 1/4" SAE, plated	1

**CRANKCASE BREATHER**

REF. PART NO.	DESCRIPTION	REQ'D
1 25-104	NUT - 1/4" N. C. hex	1
2 92-4	LOCKWASHER - 1/4" SAE	1
3 KO 275220	STUD - valve cover	1
4 KO 275143	COVER - valve	1
5 KO 231032	SEAL - breather	1
6 KO 235048	GASKET - valve cover	2
7 KO 235118	FILTER - breather	1
8 KO 235117	BAFFLE - breather	1
9 KO 235047	REED - breather	1
10 KO 235631	PLATE - breather	1

**155 CAMSHAFT AND VALVES**

14 KO 235826	VALVE - exhaust	1
15 KO 235008	VALVE - intake	1
16 KO 230170-S	INSERT - exhaust valve seat	1
17 KO 235007-S	GUIDE - valve	2
18 KO 235011	SEAT - valve spring	2
19 KO 235010	SPRING - valve	2
20 KO 230011	RETAINER - valve spring	2
21 KO 240013	LOCK - valve retainer	4
22 KOA235327	LIFTER ASSY	2
23 NSS	SCREW - tappet adjusting	1
24 NSS	LIFTER - valve	1
25 KOA235646	CAMSHAFT ASSY	1
26 KO 275066	SPACER - camshaft, .005"	UAR
26 KO 275067	SPACER - camshaft, .010"	UAR
27 KO 235053	PIN - camshaft	1

**195 CAMSHAFT AND VALVES**

37 KO 235826	VALVE - exhaust	1
38 KO 235008	VALVE - intake	1
39 KO 230170-S	INSERT - exhaust valve seat	1
40 KO 235007-S	GUIDE - valve	2
41 KO 235011	SEAT - valve spring	2
42 KO 235010	SPRING - valve	2
43 KO 230011	RETAINER - valve spring	2
44 KO 240013	LOCK - valve retainer	4
45 KOA235327	LIFTER ASSY	2
46 NSS	SCREW - tappet adjusting	1
47 NSS	LIFTER - valve	1
48 KOA235646	CAMSHAFT ASSY	1
49 KO 275066	SPACER - camshaft, .005"	UAR
49 KO 275067	SPACER - camshaft, .010"	UAR
50 KO 235053	PIN - camshaft	1

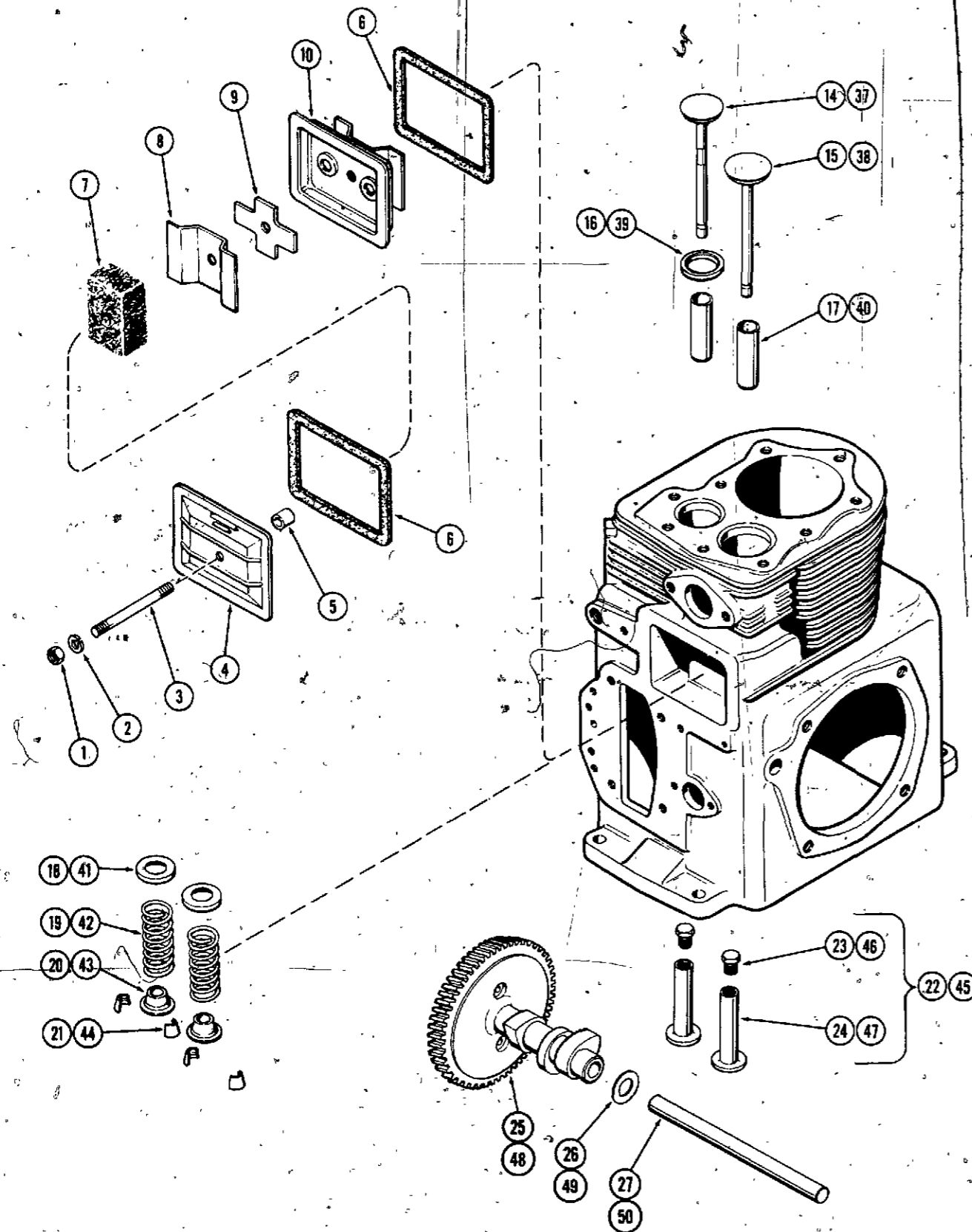

155 CRANKSHAFT, PISTON - CONNECTING ROD

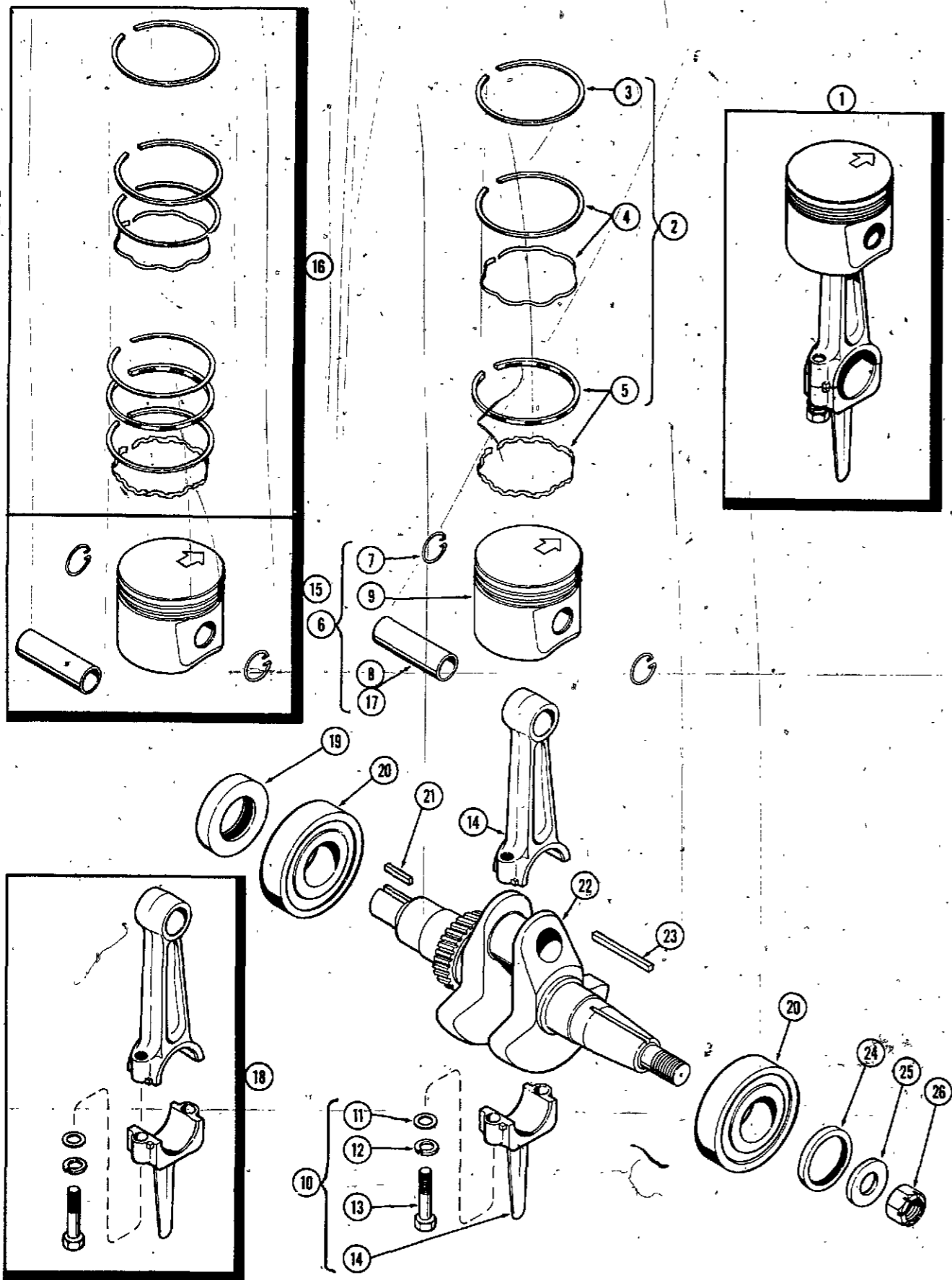

REF. PART NO.	DESCRIPTION	REQ'D
1	NSS PISTON AND ROD ASSY. (Std. size)	1
2	KO 235287 RING SET - piston (for oversize see item 16)	1
3	NSS RING - top compression	1
4	NSS RING - 2nd compression (incl. expander)	1
5	NSS RING - oil (incl. expander)	1
6	KOA235611 PISTON ASSY (for oversize see item 15)	1
7	KO 235004 RETAINER - piston pin	2
8	KO 235572 PIN - piston	1
9	NSS PISTON	1
10	KOA235139 CONNECTING ROD ASSY (for undersize see item 18)	1
11	KO 235003 WASHER - special	2
12	KOX 22-35 LOCKWASHER	2
13	KO 235526 SCREW - cap, connecting rod	2
14	NSS ROD - connecting	1
15	KOA235569 PISTON ASSY - .010" oversize	1
15	KOA235571 PISTON ASSY - .020" oversize	1
15	KOA235616 PISTON ASSY - .030" oversize	1
16	KO 235288 RING SET - piston .010" oversize	1
16	KO 235289 RING SET - piston .020" oversize	1
16	KO 235290 RING SET - piston .030" oversize	1
17	KO 235573 PIN - piston, .005" oversize	1
18	KOA235139-10 CONNECTING ROD ASSY. - .010" undersize	1
19	KOX379-6 OIL SEAL - crankshaft rear	1
20	40035 BEARING - crankshaft ball	2
21	W 5063-S KEY - 1/4" square x 3/4" (pump eplg)	1
22	KOA235711 CRANKSHAFT	1
23	KOX 366-1 KEY - flat 1/4" x 3/16" x 1-3/4" (flywheel)	1
24	KOX 271-30 OIL SEAL - crankshaft front	1
25	KOX 25-71 WASHER - 3/4"	1
26	KOX 119-14 NUT - special Marsden 3/4" NF	1

195 CRANKSHAFT, PISTON - CONNECTING ROD

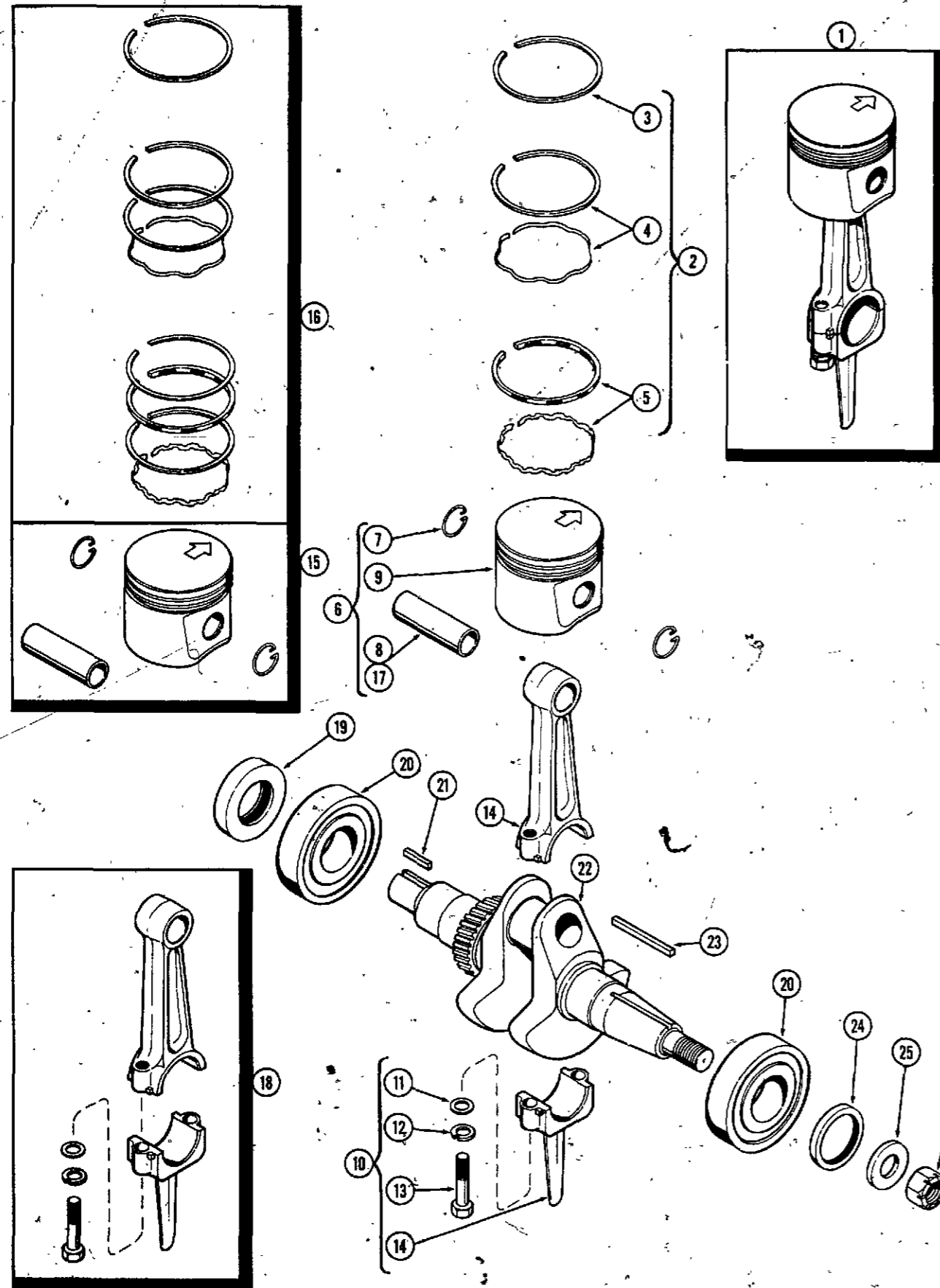

REF. PART NO.	DESCRIPTION	REQ'D
1	NSS PISTON AND ROD ASSY. (Std. size)	1
2	KO 235889 RING SET - piston (for oversize see item 16)	1
3	NSS RING - top compression	1
4	NSS RING - 2nd compression (incl. expander)	1
5	NSS RING - oil (incl. expander)	1
6	KOA235827 PISTON ASSY (for oversize see item 15)	1
7	KO 235811 RETAINER - piston pin	2
8	KO 235803 PIN - piston	1
9	NSS PISTON	1
10	KOA235828 CONNECTING ROD ASSY (for undersize see item 18)	1
11	KO 235003 WASHER - special	2
12	KOX 22-35 LOCKWASHER	2
13	KO 235526 SCREW - cap, connecting rod	2
14	NSS ROD - connecting	1
15	KOA235865 PISTON ASSY - .010" oversize	1
15	KOA235866 PISTON ASSY - .020" oversize	1
15	KOA235867 PISTON ASSY - .030" oversize	1
16	KO 235890 RING SET - piston .010" oversize	1
16	KO 235891 RING SET - piston .020" oversize	1
16	KO 235892 RING SET - piston .030" oversize	1
17	KO 235868 PIN - piston .005" oversize	1
18	KOA235828-10 CONNECTING ROD ASSY. - .010" undersize	1
19	KOX 379-6 OIL SEAL - crankshaft rear	1
20	40035 BEARING - crankshaft ball	2
21	W 5063-S KEY - 1/4" square x 3/4" (pump cplg.)	1
22	KOA235949 CRANKSHAFT	1
23	KOX 366-1 KEY - flat 1/4" x 3/16" x 1-3/4" (flywheel)	1
24	KOX271-30 OIL SEAL - crankshaft front	1
25	KOX 25-71 WASHER - 3/4"	1
26	KOX119-16 NUT - special Marsden 3/4" NF	1

155 ENGINE BLOCK AND ATTACHING PARTS

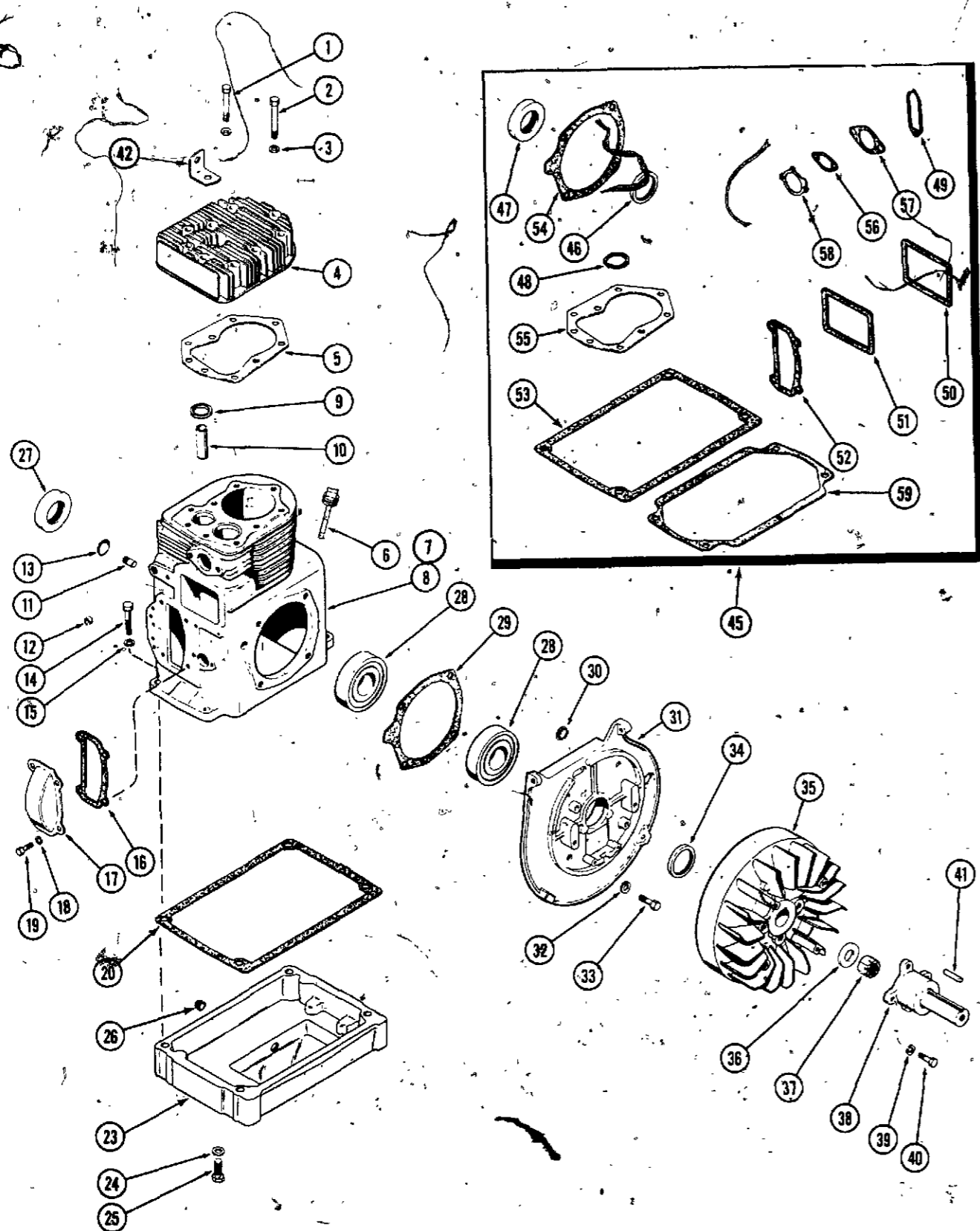

REF. PART NO.	DESCRIPTION	REQ'D
1	KO 271077 BOLT - cyl. hd. (length 2-1/4")	6
2	KO 235175 BOLT - cyl. hd. (length 2-1/2")	3
3	KO 270889 WASHER - cyl. hd. bolt	9
4	KO 235656 HEAD - cylinder	1
5	KO 235810 GASKET - head	1
6	KOA235747 DIPSTICK ASSY	1
7	KOA236303 BLOCK ASSY - cyl., short (incl. crankshaft, rod assy governor, camshaft, valves, bearings and plate)	1
8	KOA235737 BLOCK ASSY - cyl., stripped (Std. bore)	1
9	KO 230170-S INSERT - exhaust valve	1
10	KO 235007-S GUIDE - valve	2
11	KO 235125-S SHAFT - stub, governor	1
12	KOX293-4 BEARING - needle, governor shaft	1
13	41- 18 PLUG - expansion	1
14	113- 26 BOLT - 3/8" x 7/8" N.C. hex plated	4
15	192- 21 LOCKWASHER - 3/8" SAE plated	4
16	KO 235025 GASKET - camshaft cover	1
17	KO 235026 COVER - camshaft gear	1
18	192- 9 LOCKWASHER - 1/4" plated	4
19	113- 6 BOLT - 1/4" x 1/2" UNC, plated	4
20	KO 235353 GASKET - oil pan	1
21	KO 235950 BASE - oil pan	1
22	192- 21 LOCKWASHER - 3/8" plated	4
23	115- 204 BOLT - 3/8" x 1" N.C. hex plated	4
24	221- 2 PLUG - pipe, 1/4" sq. hd.	1
25	KOX 379-6 OIL SEAL - crankshaft rear	1
26	40035 BEARING - crankshaft ball	2
27	KO 235757 GASKET - shim, bearing plate, .010"	6
28	KO 235070 GASKET - shim, .010"	1
29	205- 27 PLUG - button, timing hole	1
30	KO 235062 PLATE - bearing (can use KO235815)	1
31	192- 21 LOCKWASHER - 3/8" plated	4
32	113- 207 BOLT - 3/8" x 1" N.C. plated	4
33	KOX 271-30 OIL SEAL - crankshaft front	1
34	KO 235818 FLYWHEEL	1
35	195- 545 WASHER - special, plated	1
36	KOX 119-16 NUT - special Marsden	1
37	KO 235954 SHAFT - frt. drive stub	1
38	192- 21 LOCKWASHER - 3/8" SAE plated	4
39	113- 208 BOLT - 3/8" x 1-1/4" N.C. hex	4
40	W 5063-S KEY - 1/4" sq. x 3/4"	1
41	KO 235748 STRAP - lifting	1

ENGINE GASKET AND SEAL KIT

45	KO 235165 KIT - engine gasket and seal	1
46	KOX271-30 SEAL - crankshaft front oil	1
47	KOX 379-6 SEAL - crankshaft rear oil	1
48	B 59393 GASKET - fuel strainer bowl	1
49	KO 220174 GASKET - breaker cover	1
50	KO 231032 SEAL - breather	1
51	KO 235048 GASKET - valve cover	2
52	KO 235025 GASKET - camshaft gear cover	1
53	KO 235353 GASKET - oil pan	1
54	KO 235757 GASKET - shim, bearing plate .010"	6
54	KO 235070 GASKET - shim, .010"	1
55	KO 235810 GASKET - cyl. head	1
56	A 72108 GASKET - fuel pump flange	1
57	A 72100 GASKET - carburetor flange	1
58	KO 275341 GASKET - carburetor air horn	1
59	KO 235057 GASKET - oil pan (not used on this model)	1

195 ENGINE BLOCK AND ATTACHING PARTS

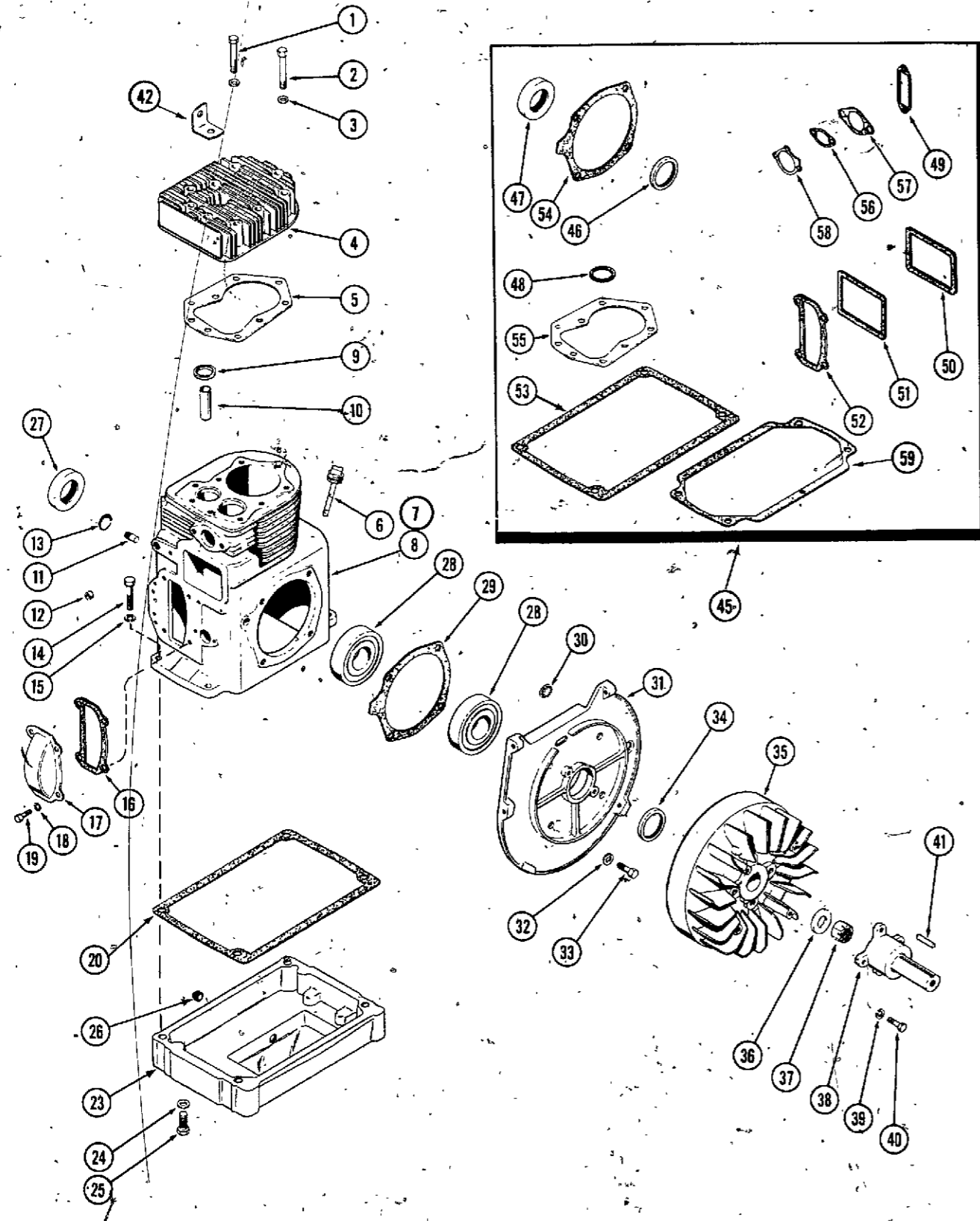

REF. PART NO.	DESCRIPTION	REQ'D
1 KO 271077	BOLT - cyl. hd. (length 2-1/4")	6
2 KO 235175	BOLT - cyl. hd. (length 2-1/2")	3
3 KO 270889	WASHER - cyl. hd. bolt	9
4 KO 235820	HEAD - cyl.	1
5 KO 235810	GASKET - head	1
6 KOA235747	DIPSTICK ASSY	1
7 KOA236293	BLOCK ASSY - cyl., short (incl. crankshaft, rod assy governor, camshaft, valves, bearings and plate)	1
8 KOA235952	BLOCK ASSY - cyl., standard bore	1
9 KO 230170-S	INSERT - exhaust valve	1
10 KO 235007-S	GUIDE - valve	2
11 KO 235125-S	SHAFT - stub, governor	1
12 KOX 293-4	BEARING - needle, governor shaft	1
13 41- 18	PLUG - expansion	1
14 113- 206	BOLT - 3/8" x 1-1/4" N.C. hex plated	4
15 192- 21	LOCKWASHER - 3/8" plated	4
16 KO 235025	GASKET - camshaft cover	1
17 KO 235026	COVER - camshaft gear	1
18 192- 19	LOCKWASHER - 1/4" plated	4
19 113- 6	BOLT - 1/4" x 1/2" UNC plated	4
20 KO 235353	GASKET - oil pan	1
23 KO 235950	BASE - oil pan	1
24 192- 21	LOCKWASHER - 3/8" plated	4
25 115- 204	BOLT - 3/8" x 1" N.C. hex plated	4
26 221- 2	PLUG - pipe, 1/4" sq. hd.	1
27 KOX379-6	OIL SEAL - crankshaft rear	1
28 40035	BEARING - crankshaft ball	2
29 KO 235757	GASKET - shim, bearing plate .010"	6
29 KO 235070	GASKET - shim, .010"	UAR
30 205- 27	PLUG - button, timing hole	1
31 KO 235815	PLATE - bearing	1
32 192- 21	LOCKWASHER - 3/8" plated	4
33 113- 207	BOLT - 3/8" x 1" N.C. plated	4
34 KOX271-30	OIL SEAL - crankshaft front	1
35 KO 235818	FLYWHEEL	1
36 195- 545	WASHER - special, plated	1
37 KOX119-16	NUT - special Marsden	1
38 KO 235954	SHAFT - frt. drive stub	1
39 192- 21	LOCKWASHER - 3/8" SAE plated	4
40 113- 208	BOLT - 3/8" x 1-1/4" N. C. hex plated	4
41 W 5063-S	KEY - 1/4" sq. x 3/4"	1
42 KO 235748	STRAP - lifting	1

ENGINE GASKET AND SEAL KIT

45 KO 235165	KIT - engine gasket and seal	1
46 KOX271-30	SEAL - crankshaft front oil	1
47 KOX 379-6	SEAL - crankshaft rear oil	1
48 B 59393	GASKET - fuel strainer bowl	1
49 KO 220174	GASKET - breaker cover	1
50 KO 231032	SEAL - breather	1
51 KO 235048	GASKET - valve cover	2
52 KO 235025	GASKET - camshaft gear cover	1
53 KO 235353	GASKET - oil pan	1
54 KO 235757	GASKET - shim, bearing plate, .010"	6
54 KO 235070	GASKET - shim, .010"	UAR
55 KO 235810	GASKET - cyl. head	1
56 A 72108	GASKET - fuel pump flange	1
57 A 72160	GASKET - carburetor flange	1
58 KO 275341	GASKET - carburetor air horn	1
59 KO 235057	GASKET - oil pan (not used on this model)	1



**BAFFLES, SHROUDS AND CLUTCH PULLEY**

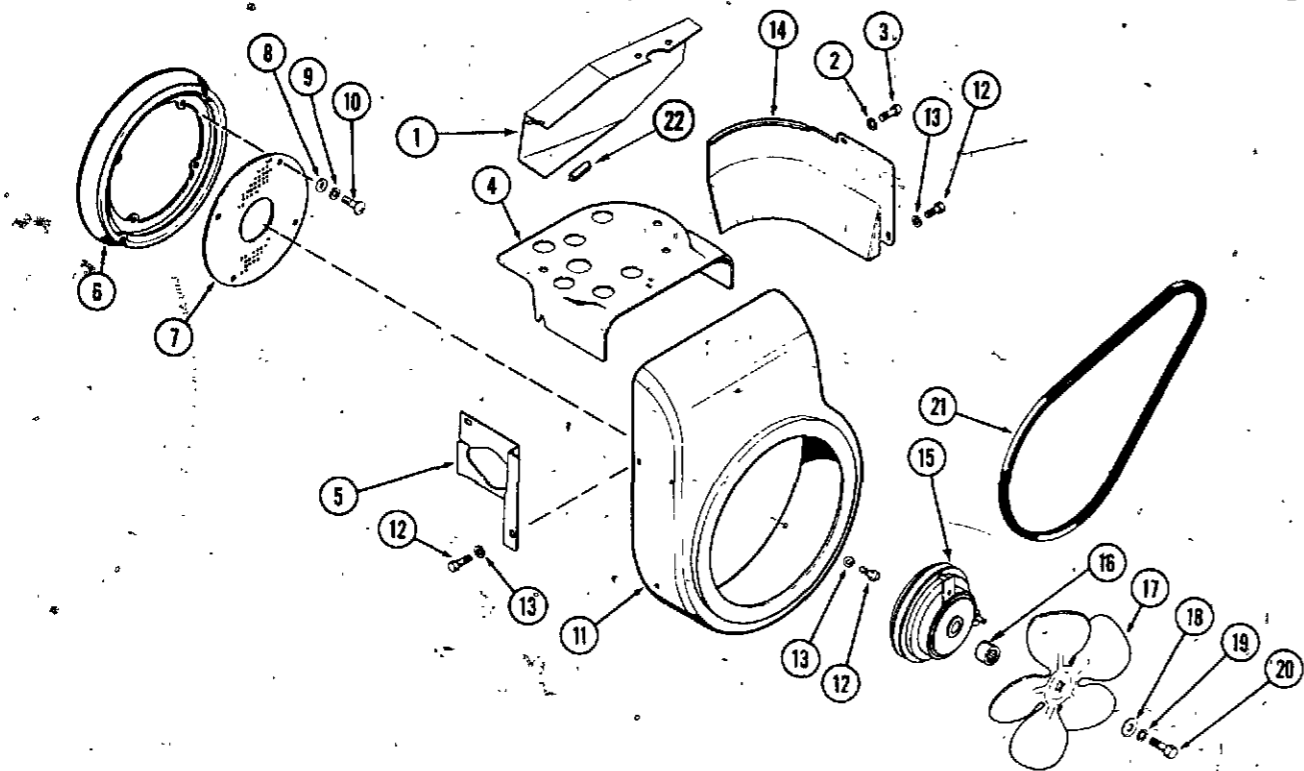

REF. PART NO.	DESCRIPTION	REQ'D
1 C 10492	DEFLECTOR - engine air	1
2 192- 19	LOCKWASHER - 1/4", plated	2
3 113- 6	BOLT - 1/4" x 1/2" N.C. hex plated	2
4 KO 235955	BAFFLE - cyl. head	1
5 KO 235368	BAFFLE - carburetor side air	1
6 KO 235207	PULLEY - starter	1
7 KO 235052	SCREEN - blower air intake	1
8 195- 515	WASHER - 1/4" plated	4
9 192- 19	LOCKWASHER - 1/4" plated	4
10 175- 436	SCREW - 1/4" x 5/8" N.C. truss hd. Phillips, plated	4
11 KO 235951	HOUSING - blower	1
12 113- 2	BOLT - 1/4" x 3/4" N.C., hex hd. plated	4
13 192- 19	LOCKWASHER - 1/4" plated	4
14 KO 235054	BAFFLE - cylinder	1
15 C 10311	CLUTCH - pulley	1
16 C 10312	SPACER - short	1
17 A 70084	FAN - engine	1
18 195- 104	WASHER - 3/8" plain	1
19 192- 21	LOCKWASHER - 3/8" SAE	1
20 115- 208	BOLT - 3/8" x 3-1/2" N.C., hex (for pulley clutch)	1
21 A 70205	BELT - drive, starter, generator	1
22 C 12603	CHANNEL - deflector	1

**CHOKE, THROTTLE AND GOVERNOR**

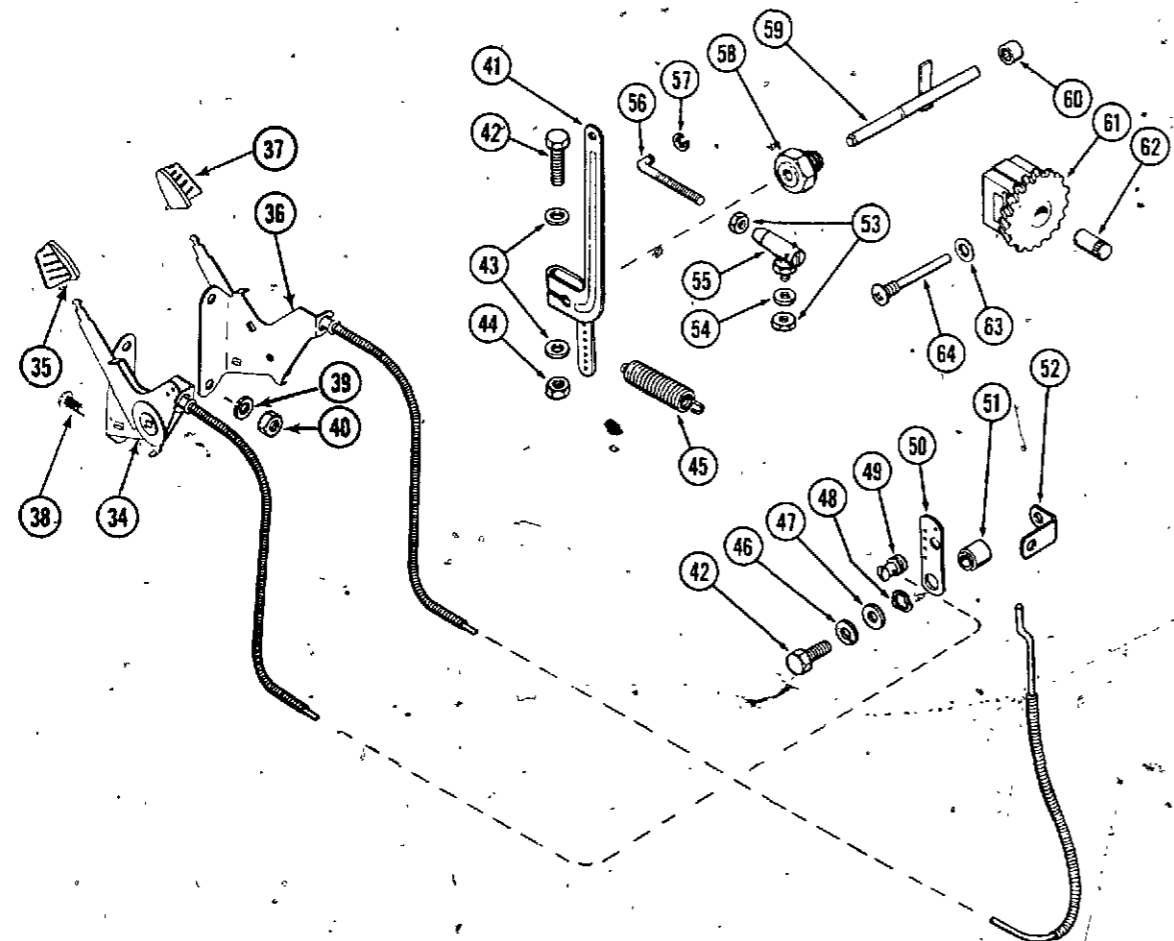

34 C 12189	CONTROL - throttle	1
35 C 12224	HANDLE - throttle control	1
36 C 12187	CONTROL - choke	1
37 C 12223	HANDLE - choke control	1
38 173- 212	SCREW - 10-24 x 1/2" rd. hd. machine, plated	2
39 192- 18	LOCKWASHER - #10 std. plated	2
40 129- 7	NUT - #10-24 plated	2
41 KO 235494	LEVER - governor	1
42 15- 420	BOLT - 1/4" x 1-1/4" N.C. hex	2
43 195- 515	WASHER - 1/4" plated	2
44 25- 104	NUT - 1/4" hex	1
45 KO 235496	SPRING - governor	1
46 192- 19	LOCKWASHER - 1/4" plated	1
47 KOX 25-67	WASHER - thrust	1
48 KO 275690	WASHER - wavy	1
49 KO 231052	CLAMP - swivel, wire	1
50 KO 235086	LEVER - speed control	1
51 KO 235085	SPACER - speed control bracket	1
52 KO 235084	BRACKET - high speed stop	1
53 129- 37	NUT - #10-32, hex	2
54 192- 18	LOCKWASHER - 3/16" plated	1
55 A 10326	JOINT - ball	1
56 KO 235277	ROD - throttle	1
57 KO 235278	RING - retaining, throttle rod	1
58 KO 235476	BUSHING - governor cross shaft	1
59 KOA235256	SHAFT ASSY - governor cross	1
60 KOX 293-4	BEARING - needle governor shaft	1
61 KOA235743	GEAR ASSY - governor	1
62 KO 235125-S	SHAFT - governor stub	1
63 KOX 25-55	WASHER - governor stop pin	1
64 KO 231355	PIN - governor stop	1

FUEL SYSTEM

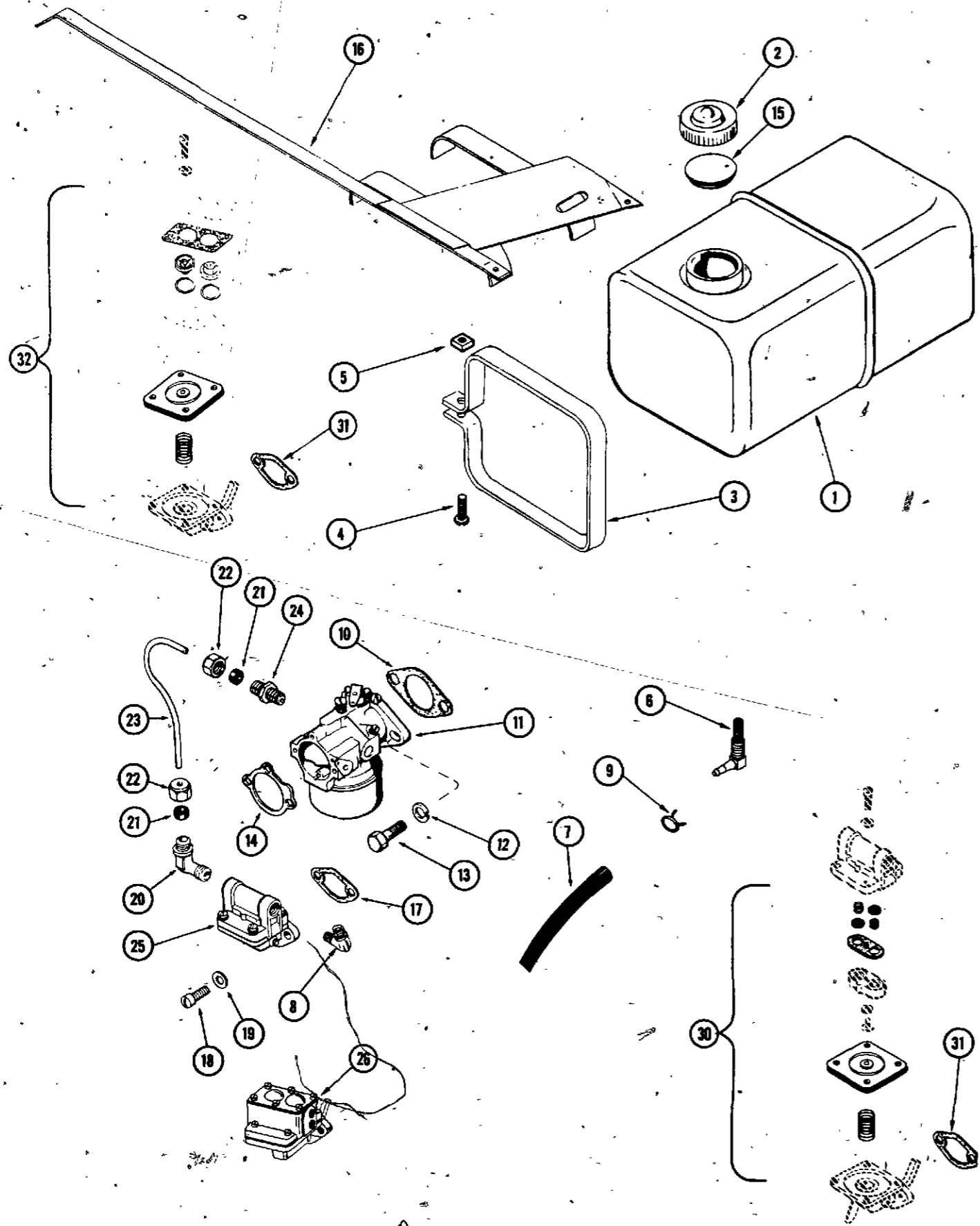

REF. PART NO.	DESCRIPTION	REQ'D
1 C 10479	TANK - fuel	1
2 C 11529	CAP - fuel tank	1
3 A 70100	STRAP - fuel tank mounting	1
4 173- 215	SCREW - 1/4" x 1-1/4" rd. hd.	2
5 131- 350	NUT - 1/4" square	2
6 C 10657	ELBOW - fuel line	1
7 C 12211	HOSE - fuel line	1
8 C 10678	FITTING - elbow, fuel line, nylon	1
9 214- 253	CLAMP - 1/2" hose	1
10 A 72100	GASKET - carburetor flange	2
11 A 72073	CARBURETOR ASSEMBLY (Repairs Page 21)	1
12 192- 20	LOCKWASHER - 5/16" SAE std.	1
13 113- 103	BOLT - 5/16" x 1" N.C. hex head	2
14 KO275341	GASKET - air horn	2
15 C 11545	INSERT - fuel cap	1
16 C 12203	BRACKET - fuel tank mounting	1
17 A 72108	GASKET - fuel pump mounting	1
18 71- 410	SCREW - 1/4" x 5/8" N.C. fillister head	1
19 193- 60	LOCKWASHER - 1/4" SAE std.	2
20 222- 41	ELBOW - includes sleeve and nut	1
21 222- 101	SLEEVE - for 3/16" O.D. tube	1
22 222- 112	NUT - for 3/16" O.D. tube	2
23 KO235097	LINE - fuel pump to carburetor	1
24 222- 4021	CONNECTOR ASSEMBLY - includes sleeve and nut	1
25 KOA235845	FUEL PUMP - (for 10 HP model) (155)	1
26 KOA236205	FUEL PUMP - (for 12 HP model) (195)	1

FUEL PUMP

30 KO 230675	FUEL PUMP KIT - for KOA235845 pump	1
NSS	SPRING - fuel pump valve	2
NSS	VALVE - fuel pump	2
NSS	GASKET - valve	1
NSS	DIAPHRAGM ASSEMBLY	1
NSS	SPRING - diaphragm	1
31 A 72108	GASKET - fuel pump mounting	1
32 KO 236387	FUEL PUMP KIT - for KOA236205 pump	1
NSS	GASKET - valve housing	1
NSS	VALVE ASSEMBLY	2
NSS	GASKET - valve	2
NSS	DISPHRAGM ASSEMBLY	1
NSS	SPRING - diaphragm	1
31 A 72108	GASKET - fuel pump mounting	1

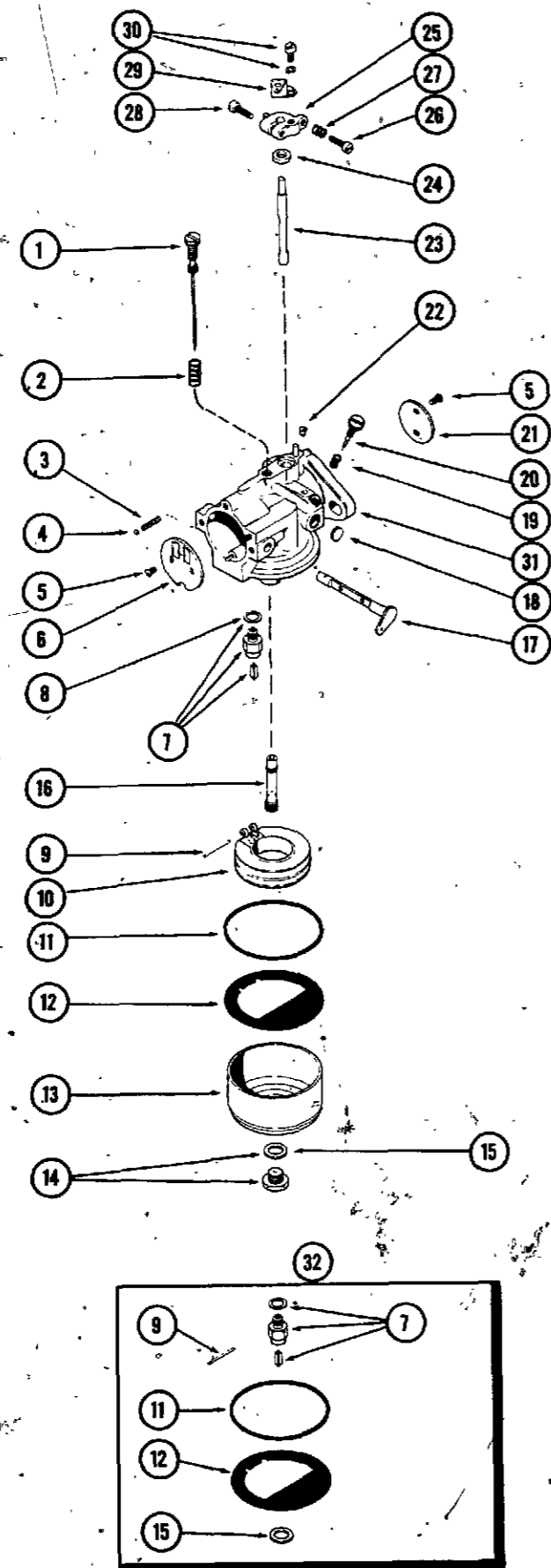

**A72073 CARBURETOR**

REF. PART NO.	DESCRIPTION	REQ'D
	CARBURETOR ASSY .....	1
1 A 72077	JET ASSY - high speed & idle adj. ....	1
2 A 72076	SPRING - idle jet. ....	1
3 A 72085	SPRING - choke detent ball. ....	1
4 211- 3	BALL - 1/8" steel. ....	1
5 A 72091	SCREW - #3-48 rd. hd. mach., brass. ....	4
6 A 72074	VALVE ASSY - choke disc. ....	1
7 A 72086	INLET NEEDLE & SEAT ASSY. ....	1
8 A 72102	GASKET - needle seat. ....	1
9 A 72079	PIN - carburetor float. ....	1
10 A 72078	FLOAT ASSY. ....	1
11 A 72081	GASKET - carburetor bowl ring. ....	1
12 A 72082	GASKET - carburetor bowl. ....	1
13 A 72080	BOWL - carburetor. ....	1
14 A 72084	NUT & GASKET ASSY - bowl. ....	1
15 A 72083	GASKET - bowl screw. ....	1
16 A 72101	SEAT - high idle jet. ....	1
17 A 72075	SHAFT & LEVER ASSY - choke. ....	1
18 A 72087	PLUG - 3/8" expansion. ....	1
19 A 72098	SPRING - lean-rich adjusting screw. ....	1
20 A 72099	SCREW - adjusting (lean-rich). ....	1
21 A 72090	VALVE - throttle disc. ....	1
22 A 72088	PLUG - carb. body passage. ....	1
23 A 72089	SHAFT - throttle lever. ....	1
24 A 72097	SEAL - throttle shaft. ....	1
25 A 72094	DOG ASSY - throttle shaft. ....	1
26 A 72092	SCREW - idle stop. ....	1
27 A 72093	SPRING - idle screw tension. ....	1
28 169- 77	SCREW - throttle dog clamp #8 x 1/2" N.C. fill. hd. ....	1
29 A 72096	LEVER - throttle. ....	1
30 A 72095	SCREW ASSY - throttle lever. ....	1
31 NSS	BODY - carb. (Order A72073 Carb. Assy) ....	1
32 A 72103	KIT - carburetor repair. ....	1

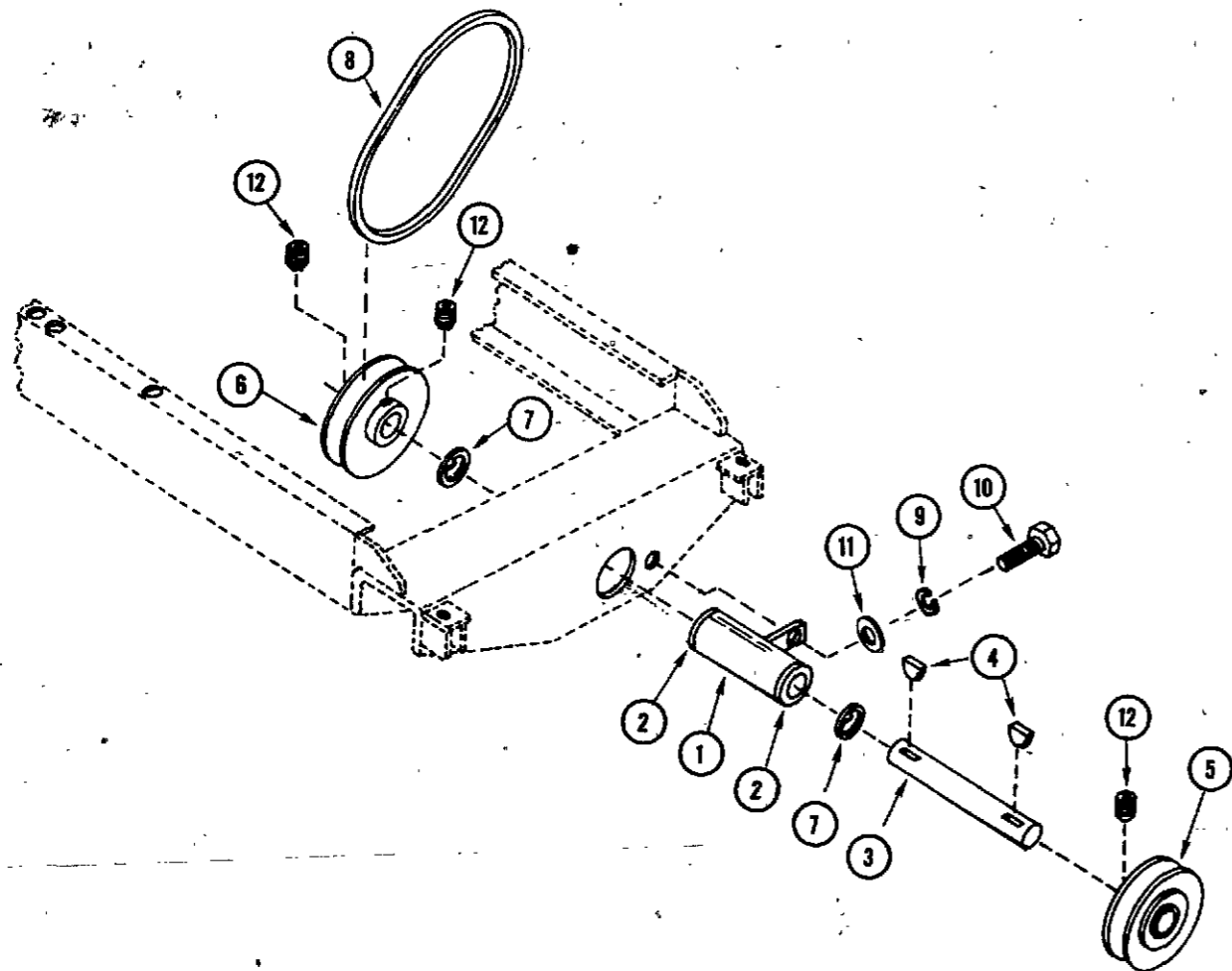
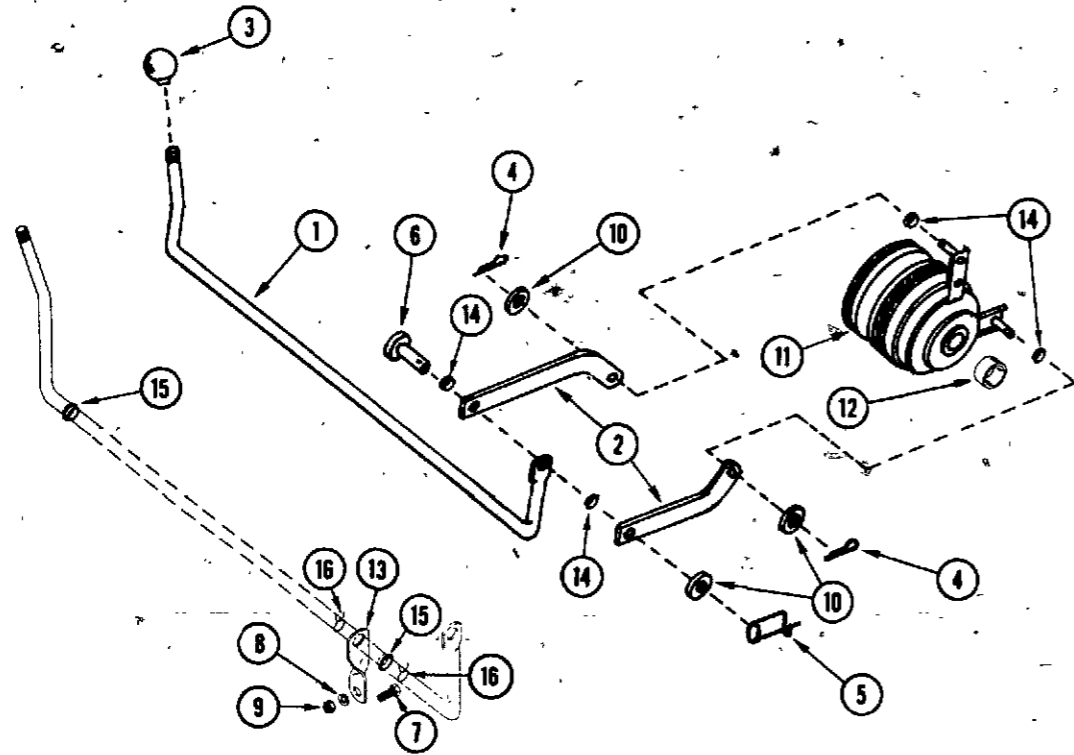

**PULLEY CLUTCH.**

REF. PART NO.	DESCRIPTION	REQ'D
1 C 12096	LEVER - clutch control	1
2 C 12094	LINK - clutch control	2
3 C 10487	KNOB - lever	1
4 132- 24	PIN - cotter 3/32" x 1/2"	2
5 C 10883	PIN - safety	1
6 141- 2	PIN - clevis, 1/4" x 3/4"	1
7 115- 103	BOLT - 5/16"-18 N.C. x 3/4" plated	1
8 192- 20	LOCKWASHER - 5/16" SAE plated	1
9 129- 102	NUT - 5/16"-18 N.C. plated	1
10 195- 517	WASHER - 1/4" plain plated	3
11 C 10311	CLUTCH - PTO "V" belt (parts not serviced)	1
12 C 10312	SPACER - fan, short	1
13 C 10827	BRACKET - PTO control	1
14	BUSHING - (not used)	
15	BUSHING - (not used)	
16 214- 101	CLAMP - 3/8" LD.	2

**FRONT P. T. O. (OPTIONAL)**

1 C 10500	CARRIER - pivot and bearing	1
2 C 10502	BEARING - sintered bronze	2
3 C 10503	SHAFT - PTO pulley	1
4 126- 22	KEY - Woodruff #13 SAE	2
5 C 10504	PULLEY - drive	1
6 C 10505	PULLEY - driven adjustable	1
7 C 10506	WASHER - thrust	2
8 C 10507	BELT - 3 V section 30"	1
9 192- 21	LOCKWASHER - 3/8" SAE	1
10 113- 221	BOLT - 3/8"-16 x 7/8" hex head	1
11 195- 522	WASHER - 3/8" SAE plain	1
12 83- 56	SETSCREW - 5/16" x 3/8" socket head	3

**A70202 STARTER-GENERATOR**

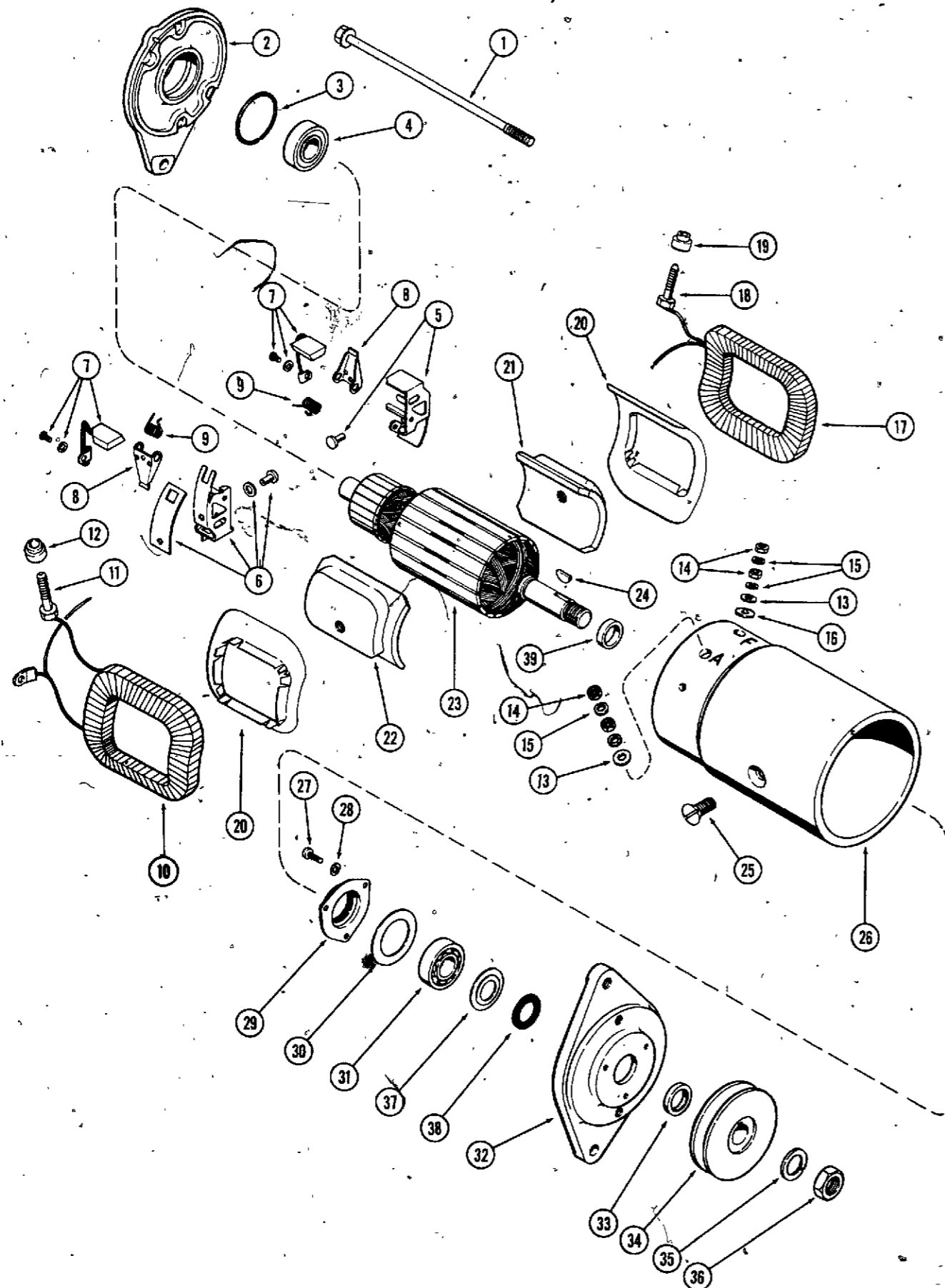

REF. PART NO.	DESCRIPTION	REQ'D
1 R 15106	BOLT - thru (includes washer)	2
2 A 72104	FRAME ASSY - commutator end	1
3 R 15087	RING - bearing retainer	1
4 A 25461	BEARING - commutator end ball	1
5 A 72039	HOLDER KIT - ground brush	1
6 A 72040	HOLDER KIT - insulated brush	1
7 A 72038	BRUSH ASSY	2
8 R 15090	ARM - brush pressure	2
9 A 25423	SPRING - brush arm	2
10 A 72042	COIL ASSY - field R.H.	1
11 A 72048	STUD - armature terminal	1
12 R 16147	BUSHING - insulated, armature stud	1
13 R 15079	WASHER - armature stud	1
14 192- 8	NUT - terminal stud 12-24 hex	2
15 192- 17	LOCKWASHER - terminal stud #12	4
16 R 16148	WASHER - insulated, field stud	4
17 A 72043	COIL ASSY - field, L.H.	1
18 A 72049	STUD - field terminal	1
19 R 15077	BUSHING - insulated, field stud	1
20 A 25447	INSULATOR - field coil	1
21 A 72044	SHOE - pole, plain	2
22 A 40736	SHOE - pole, notched	1
23 A 72041	ARMATURE	1
24 126- 111	KEY - Woodruff, armature	1
25 D 32477	SCREW - pole	1
26 NSS	BODY - starter generator (Order A70202)	2
27 173- 237	SCREW - 10-32 x 1/2" rd. Hd.	1
28 192- 18	LOCKWASHER - 3/16" plated	3
29 A 72050	RETAINER ASSY - bearing (includes ref. 37 & 38)	3
30 R 16170	GASKET - bearing retainer	1
31 A 25441	BEARING - ball, drive end	1
32 A 72046	FRAME ASSY - drive end	1
33 A 72047	SPACER - pulley	1
34 KO 235260	PULLEY - starter - generator drive	1
35 192- 26	LOCKWASHER - 11/16" plated	1
36 R 15105	NUT - armature shaft, drive end	1
37 NSS	RETAINER - grease (Order A72050)	1
38 NSS	SEAL - felt (Order A72050)	1
39 NSS	SPACER - armature shaft, inner	1

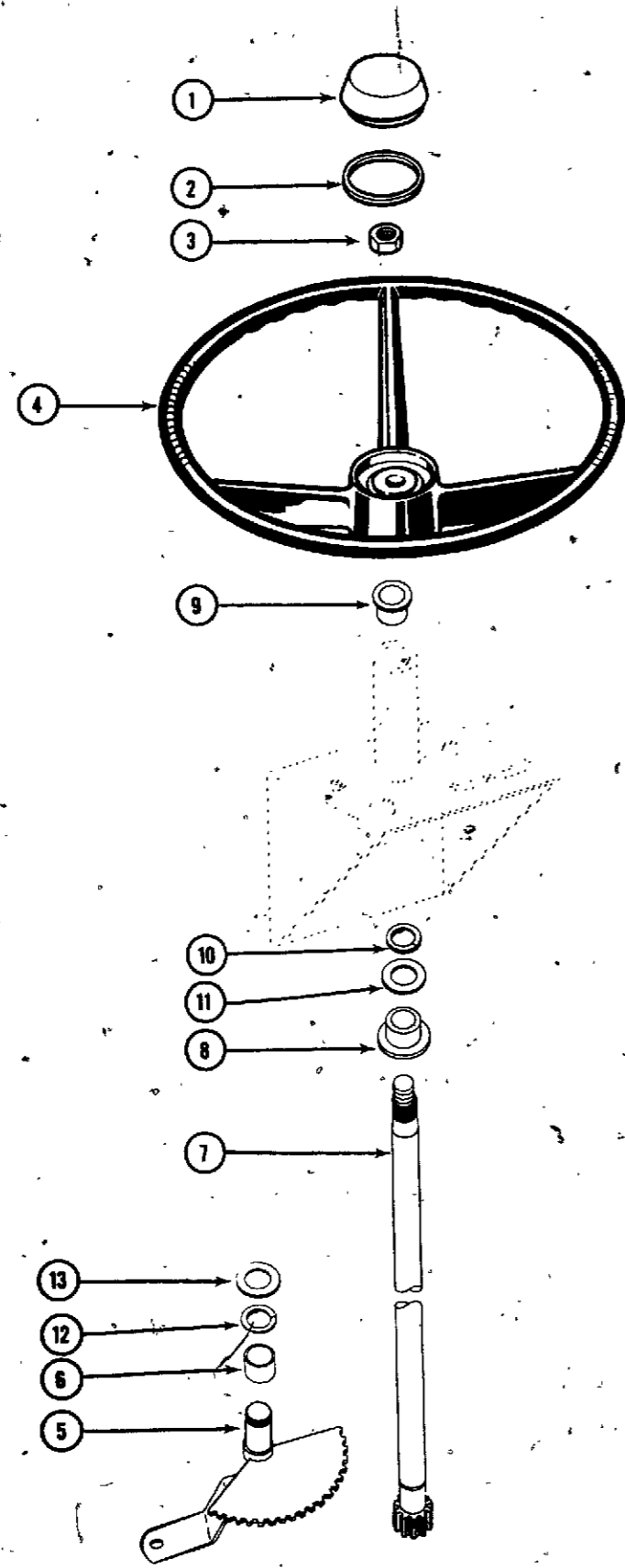

STEERING GEAR

REF. PART NO.	DESCRIPTION	REQ'D
1 C 10569	CAP - steering wheel	1
2 C 10570	RING - cap retainer	1
3 25- 1510	NUT - jam, 5/8"-18 FHNUNF.	1
4 A .70058	WHEEL - steering	1
5 C 11676	GEAR - steering	1
6 C 12206	BUSHING - bronze 3/4" I.D. x 7/8" O.D. x 7/8" long	1
7 C 11685	SHAFT - steering (195)	1
7 C 12116	SHAFT - steering (155)	1
8 C 12205	BUSHING - flange	1
9 C 12126	BUSHING - nylon	1
10 T 25683	RING - retaining	1
11 C 12125	WASHER - thrust	1
12 C 12007	RING - external retaining	1
13 195- 2082	WASHER	1

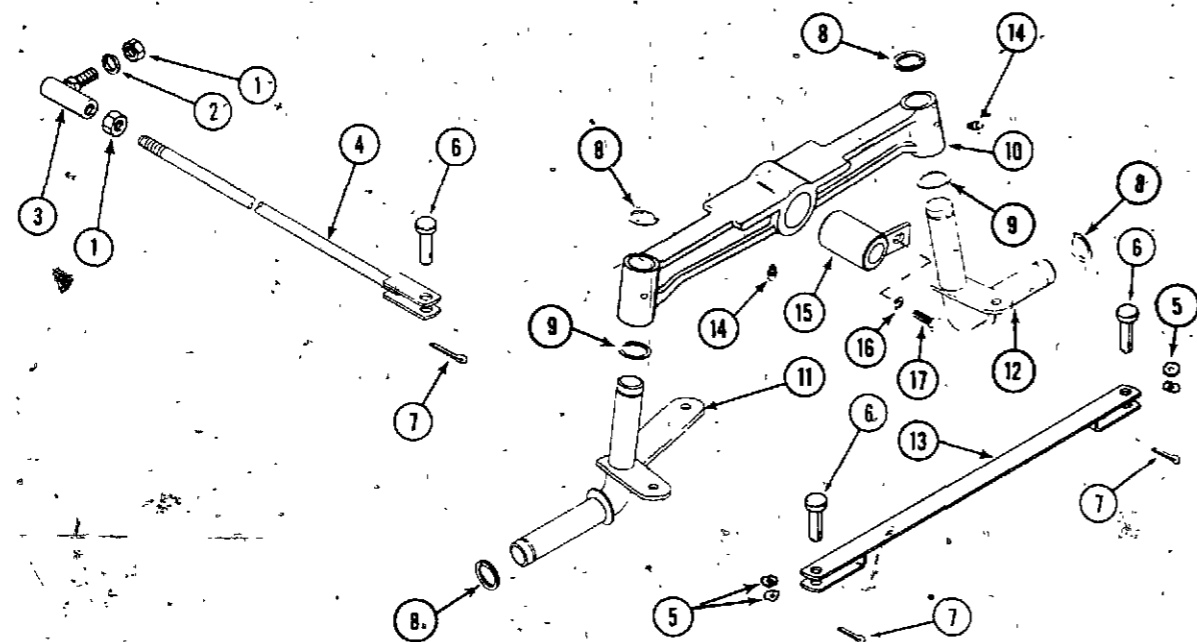

**155 FRONT AXLE**

REF. PART NO.	DESCRIPTION	REQ'D
1 25- 118	NUT - 1/2" FHNUNC	
2 92- 8	LOCKWASHER - 1/2" SAE std.	2
3 C 12102	JOINT, ball, 1/2"	2
4 C 12527	ROD - drag link	1
5 C 12115	WASHER - spring	1
6 141- 6	PIN - tie bar and drag link	4
7 132- 47	PIN - cotter, 1/8" x 7/8"	3
8 C 12007	RING - external retaining	3
9 C 11906	WASHER - thrust, 3/4"	4
10 C 11999	AXLE - front	2
11 C 11842	SPINDLE - right hand	1
12 C 11841	SPINDLE - left hand	1
13 C 10235	TIE BAR - spindle	1
14 219- 8	FITTING - lube, 1/8"-28	1
15 C 12003	PIN - axle pivot (See C12005 for tractor w/PTO)	3
16 192- 21	LOCKWASHER - 3/8" SAE	1
17 113- 205	BOLT - 3/8"-16 x 5/8" hex head	1

**195 FRONT AXLE**

20 25- 118	NUT - 1/2" FHNUNC	6
21 92- 8	LOCKWASHER - 1/2" SAE std.	6
22 C 12102	JOINT - ball, 1/2"	3
23 C 12104	ROD - drag link	1
24 132- 47	PIN - cotter, 1/8" x 7/8"	3
25 141- 6	PIN - drag link	1
26 C 12007	RING - external retaining	1
27 C 12000	AXLE - front	2
28 C 11902	SPINDLE - right hand	1
29 C 11953	SPINDLE - left hand	1
30 C 10246	TIE ROD	1
31 219- 8	FITTING - lube, 1/8"-28	1
32 C 12003	PIN - axle pivot (See C12005 for tractor w/PTO)	3
33 192- 21	LOCKWASHER - 3/8" SAE	1
34 113- 205	BOLT - 3/8"-16 x 5/8" hex head.	1
35 C 12008	RING - external retaining	2
36 W 8433-S	WASHER - thrust, 1"	2

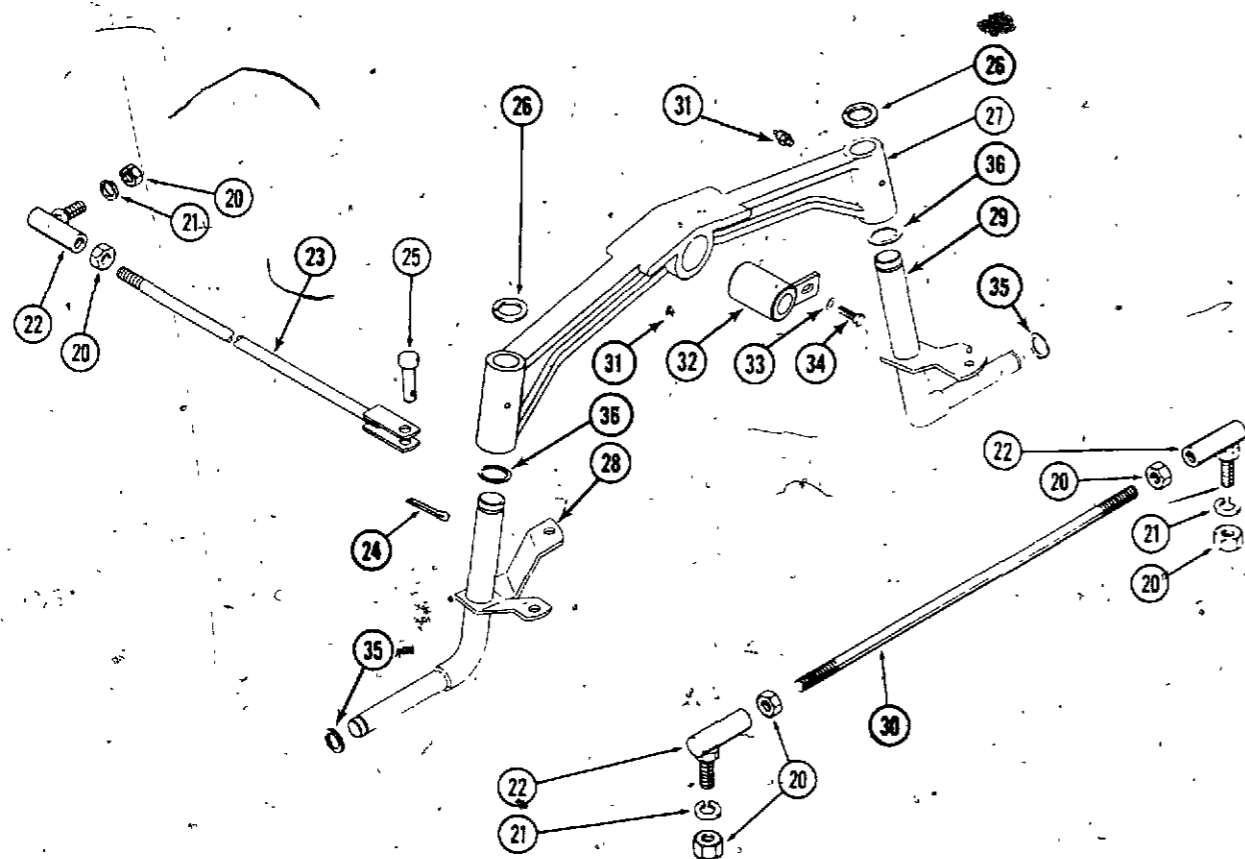

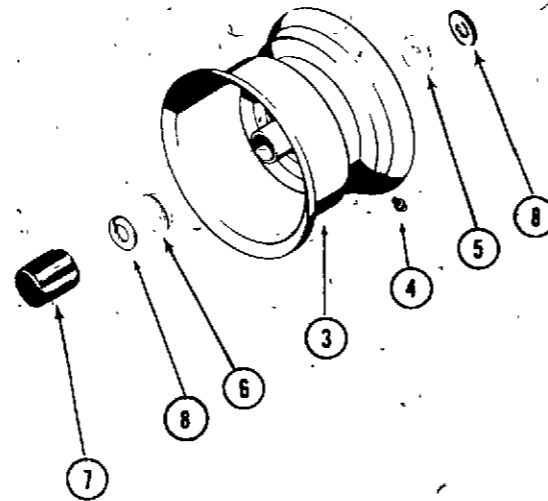
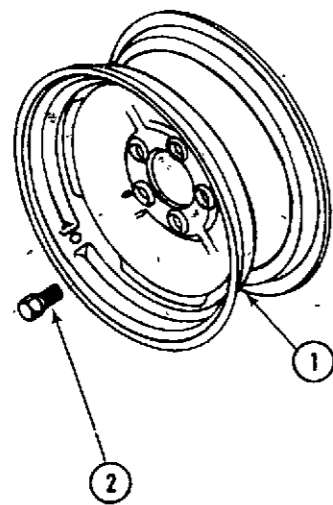

155 FRONT AND REAR WHEELS

REF. PART NO.	DESCRIPTION	REQ'D
1 C 10263	WHEEL - rear	2
2 C 10314	BOLT - rear wheel	10
3 C 12081	WHEEL - front	2
4 219- 1	FITTING - lube, 1/8" NPT	2
5 C 12110	BEARING - front wheel (inner)	2
6 C 12111	BEARING - front wheel (outer)	2
7 C 12370	CAP - plastic, front wheel	2
8 C 12007	RING - external retainer	2

195 FRONT AND REAR WHEELS

11 C 10317	WHEEL - rear	2
12 A 30064	BOLT - rear wheel	12
13 C 12081	WHEEL - front	2
14 219- 1	FITTING - lube, 1/8" NPT	2
15 C 12110	BEARING - front wheel (inner)	2
16 C 12111	BEARING - front wheel (outer)	2
17 C 12370	CAP - plastic, front wheel	2
18 C 12007	RING - external retainer	2

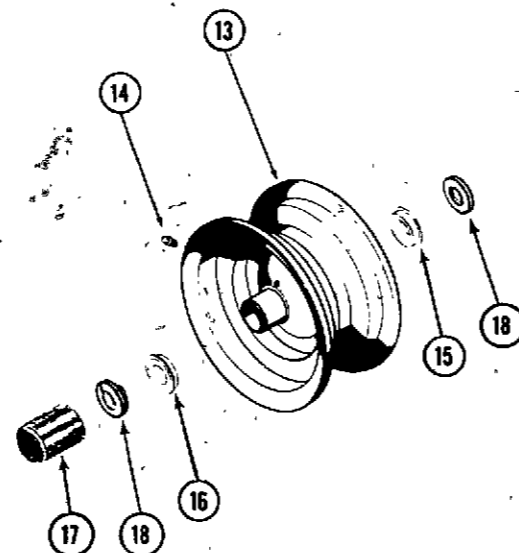
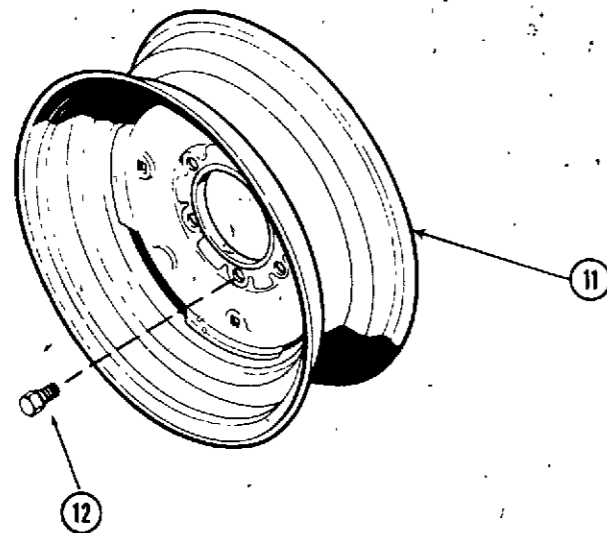



TRANSMISSION AND FINAL DRIVE

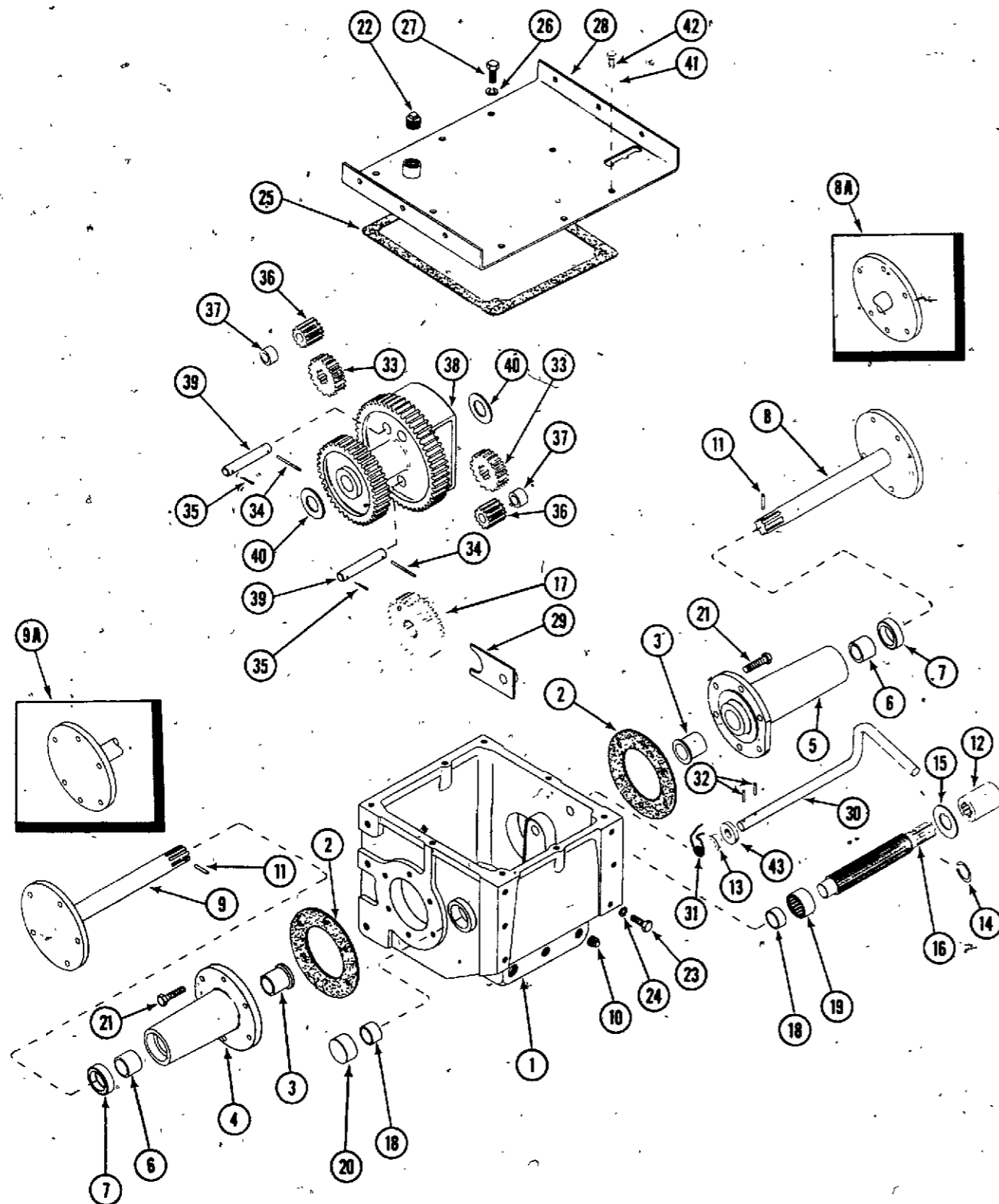

REF. PART NO.	DESCRIPTION	REQ'D
1 C 11640	CASE - transmission	1
2 A 70137	GASKET - housing to case	2
3 A 70142	BUSHING - flanged, rear axle housing	2
4 C 10294	HOUSING - rear axle, right hand	1
5 C 10295	HOUSING - rear axle, left hand	1
6 A 70141	BUSHING - plain, rear axle housing	2
7 A 70143	SEAL - rear axle housing	2
8 C 10287	SHAFT - axle, left hand (155)	1
8A C 10289	SHAFT - axle, left hand (195)	1
9 C 10286	SHAFT - axle, right hand (155)	1
9A C 10288	SHAFT - axle, right hand (195)	1
10 221- 4	PLUG - pipe, 1/2" square head	1
11 138- 102	PIN - axle retaining	2
12 C 10259	COUPLING - motor input	1
13 C 12156	BUSHING - nylon	1
14 B 18208	RING - coupling, retaining	1
15 C 10291	WASHER - input shaft stop	1
16 C 11998	SHAFT, transmission input	1
17 C 12009	CLUSTER - input gear	1
18 C 10299	RACE - bearing inner	2
19 F 19478	BEARING - input shaft, middle	1
20 C 12013	BEARING - input shaft, end	1
21 A 70127	BOLT - 3/8" x 1-1/4" N.C., special sealing	12
22 C 10303	PLUG - breather, transmission	1
23 13- 820	BOLT - 1/2" x 1-1/4" case to frame	6
24 92- 8	LOCKWASHER, 1/2" SAE	6
25 C 10302	GASKET - transmission case cover	1
26 92- 5	LOCKWASHER - 5/16" SAE	7
27 13- 512	BOLT - 5/16" x 3/4" N.C., trans. cover	7
28 C 10296	COVER - transmission case	1
29 C 12011	FORK - gear shift	1
30 C 10254	LEVER - shift	1
31 C 10261	SPRING - shift lever	1
32 138- 2002	PIN - shift fork, locating	2
33 C 10253	GEAR - differential	2
34 138- 2036	PIN - differential pin, locking	2
35 132- 91	PIN - cotter, 3/16" x 1"	4
36 C 10252	PINION - differential	4
37 A 70131	SPACER - differential pinion	4
38 C 10243	HOUSING - differential gear	1
39 C 10298	PIN - differential pinion	4
40 C 10292	WASHER - transmission	2
41 95- 5	WASHER - 5/16" SAE, plain	3
42 13- 510	BOLT - 5/16" x 5/8" trans. cover	1
43 C 11332	SEAL - shift shaft oil	1

HYDRAULIC SYSTEM

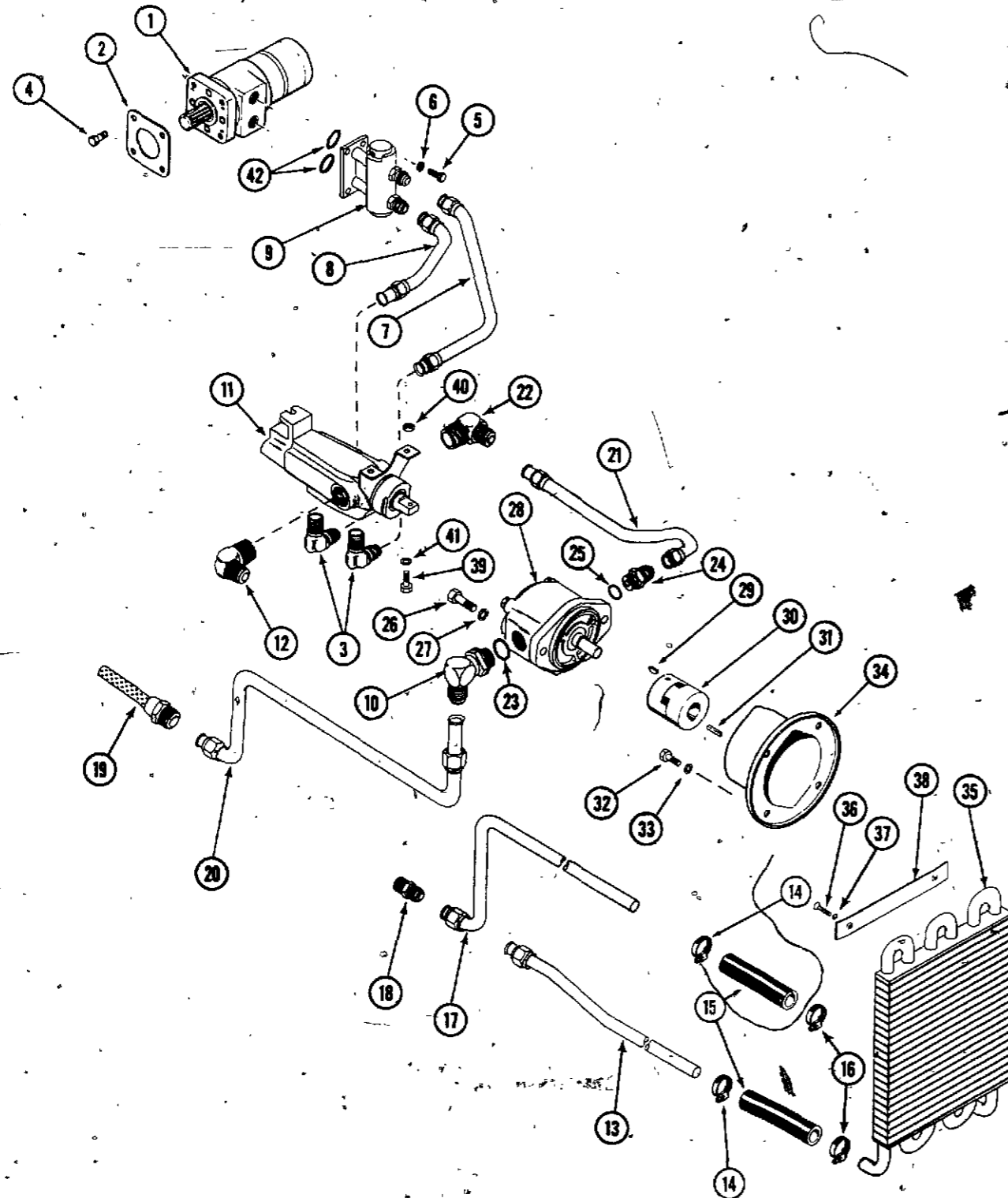

REF. PART NO.	DESCRIPTION	REQ'D
1 C 10270	MOTOR - hydraulic (195) Repairs Page 41	1
1 C 10271	MOTOR - hydraulic (155) Repairs Page 41	1
2 A 70128	GASKET - motor to transfer case	1
3* 218- 493	FITTING - 90°, 1/2" tube x 1/2" NPT	1
3** 218- 5106	FITTING - 90° elbow, 1/2" tube x 3/4"-16 "O" ring	2
4 A 70127	BOLT - special, Jay-Lock	4
5 166- 23	BOLT - 5/16"-18 x 5/8" N.C.	4
6 193- 29	LOCKWASHER - 5/16" internal tooth	4
7 C 12049	TUBE - frt. valve port to brake (195)	1
7 C 12051	TUBE - frt. valve port to brake (155)	1
8 C 12050	TUBE - rear valve port to brake (195)	1
8 C 12052	TUBE - rear valve port to brake (155)	1
9 C 10528	VALVE - park and brake (Repairs Page 49)	1
10 218- 5108	FITTING - 90°, 3/4" tube x 1-1/16" thread	1
11* C 10495	VALVE - control NPT ports (Repairs Page 37)	1
11** C 12149	VALVE - control SAE ports (Repairs Page 37)	1
12 218- 494	FITTING - 90°, 5/8" tube x 3/4" NPT	1
13 C 10266	TUBE - heat exchanger to valve	1
14 C 10418	CLAMP - hose (tube end)	2
15 C 10419	HOSE	2
16 C 10677	CLAMP - hose (heat exchanger end)	2
17 C 10267	TUBE - trans. to heat exchanger (195)	1
17 C 12067	TUBE - trans. to heat exchanger (155)	1
18 218- 445	FITTING - 3/4" tube x 3/4" NPT	1
19 A 70117	FITTING - w/filter	1
20 C 10264	TUBE - pump to transmission (195)	1
20 C 12070	TUBE - pump to transmission (155)	1
21 C 10265	TUBE - pump to valve	1
22 218- 1056	FITTING - 90° elbow, 1/2" tube x 3/4" thread	1
23 218- 5006	"O" RING - 1/2"	1
24 218- 5059	FITTING - "O" ring, 1/2" tube x 3/4" thread	1
25 218- 5008	"O" RING - 3/4"	1
26 166- 561	SCREW - ferry cap, 7/16"-20 x 1"	2
27 193- 31	LOCKWASHER - 7/16" external tooth	2
28 C 10493	PUMP - hydraulic (195) (Repairs Page 39)	1
28 C 10258	PUMP - hydraulic (155) (Repairs Page 39)	1
29 126- 12	KEY - Woodruff	1
30 A 70111	COUPLING - (Repairs Page 39)	1
31 W 5063-S	KEY - 1/4" square x 3/4"	1
32 113- 207	BOLT - 3/8" x 1" N.C. hex plated	4
33 192- 21	WASHER - 3/8" plated	4
34 A 70109	SUPPORT - hydraulic pump mounting	1
35 C 12072	EXCHANGER - heat	1
36 171- 209	SCREW - 1/4" x 1" N.C. hex plated	4
37 193- 52	LOCKWASHER - 1/4" external tooth	4
38 C 10348	BRACKET - heat exchanger	2
39 73- 410	SCREW - 1/4"-20 x 5/8" N.C. flat head	2
40 25- 104	NUT - 1/4"-20 N.C.	2
41 92- 4	LOCKWASHER - 1/4" SAE	2
42 A 27410	"O" RING-	2

\* Used on Model 155 tractors with serial numbers beginning with 9615251 and ending with 9615379. Used on Model 195 tractors with serial numbers beginning with 9620251 and ending with 9620323.

\*\* Used on Model 155 tractors with serial numbers 9615380 and up.  
Used on Model 195 tractors with serial numbers 9620324 and up.  
Printed in U. S. A.

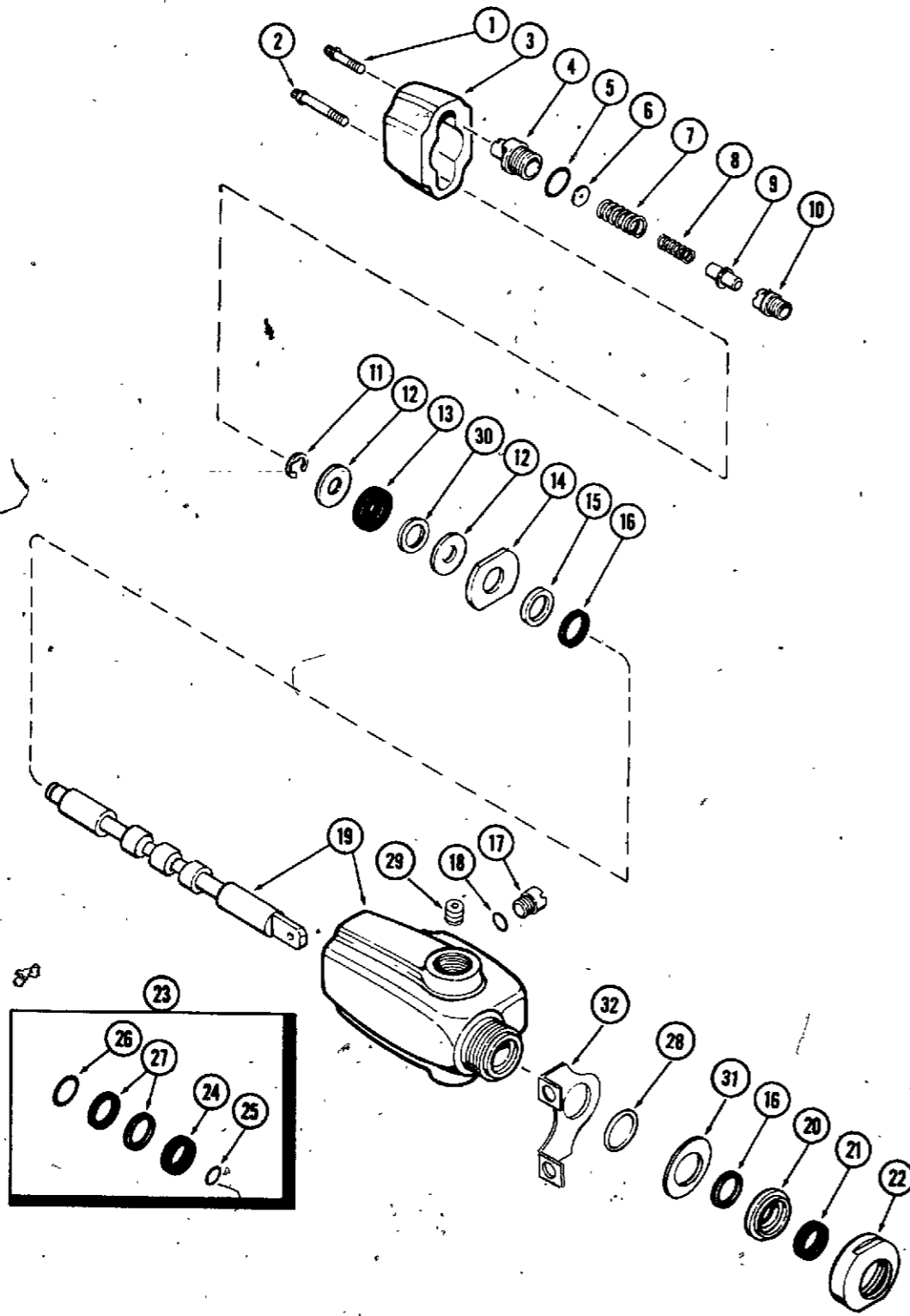

HYDRAULIC CONTROL VALVE

REF. PART NO.	DESCRIPTION	REQ'D
1 166- 6	CAPSCREW - 1/4" x 1" N.C. ferry hd.	1
2 166- 8	CAPSCREW - 1/4" x 1-1/2" N. C. ferry hd.	1
3 A 72065	CAP - valve end	1
4 A 72059	PLUG - relief valve	1
5 A 7982	"O" RING - relief valve plug	1
6 A 72069	SHIM - relief valve	2
7 A 72058	SPRING - relief valve (outer)	1
8 A 72071	SPRING - valve relief (inner)	1
9 A 72057	SPOOL - relief valve poppet	1
10 A 72055	SEAT - relief valve	1
11 O 9638 AB	SNAP RING - valve	1
12 A 72060	WASHER - valve spool end spacer	2
13 A 72063	SPACER - valve spool end	1
14 A 72066	WASHER - retainer relief valve plug	1
15 A 72067	RING - back up	1
16 A 72062	SEAL - quad ring	2
17 A 72056	PLUG	1
18 A 72061	"O" RING - plug	1
19* A 72052	BODY AND SPOOL ASSY, NPT Ports	1
19** C 12524	BODY AND SPOOL ASSY-SAE Ports	1
20 A 72068	RETAINER - seal	1
21 A 72070	SEAL - vee	1
22 A 72064	CAP - valve end	1
23 A 72072	KIT - valve seal repair	1
24 A 72070	SEAL - vee	1
25 A 72061	"O" RING - 5/8"	1
26 A 7982	"O" RING - 13/16"	1
27 A 72062	QUAD RING	2
28 T 13224	SEAL - "O" ring	1
29 C 10990	PLUG - conversion	1
30 C 10989	WASHER	1
31 C 10988	WASHER - special	1
32 C 10987	BRACKET MOUNTING	1

\* Used on Model 155 tractors with serial numbers beginning with 9615251 and ending with 9615379. Used on Model 195 tractors with serial numbers beginning with 9620251 and ending with 9620323.

\*\* Used on Model 155 tractors with serial numbers 9615380 and up. Used on Model 195 tractors with serial numbers 9620324 and up.

HYDRAULIC PUMP

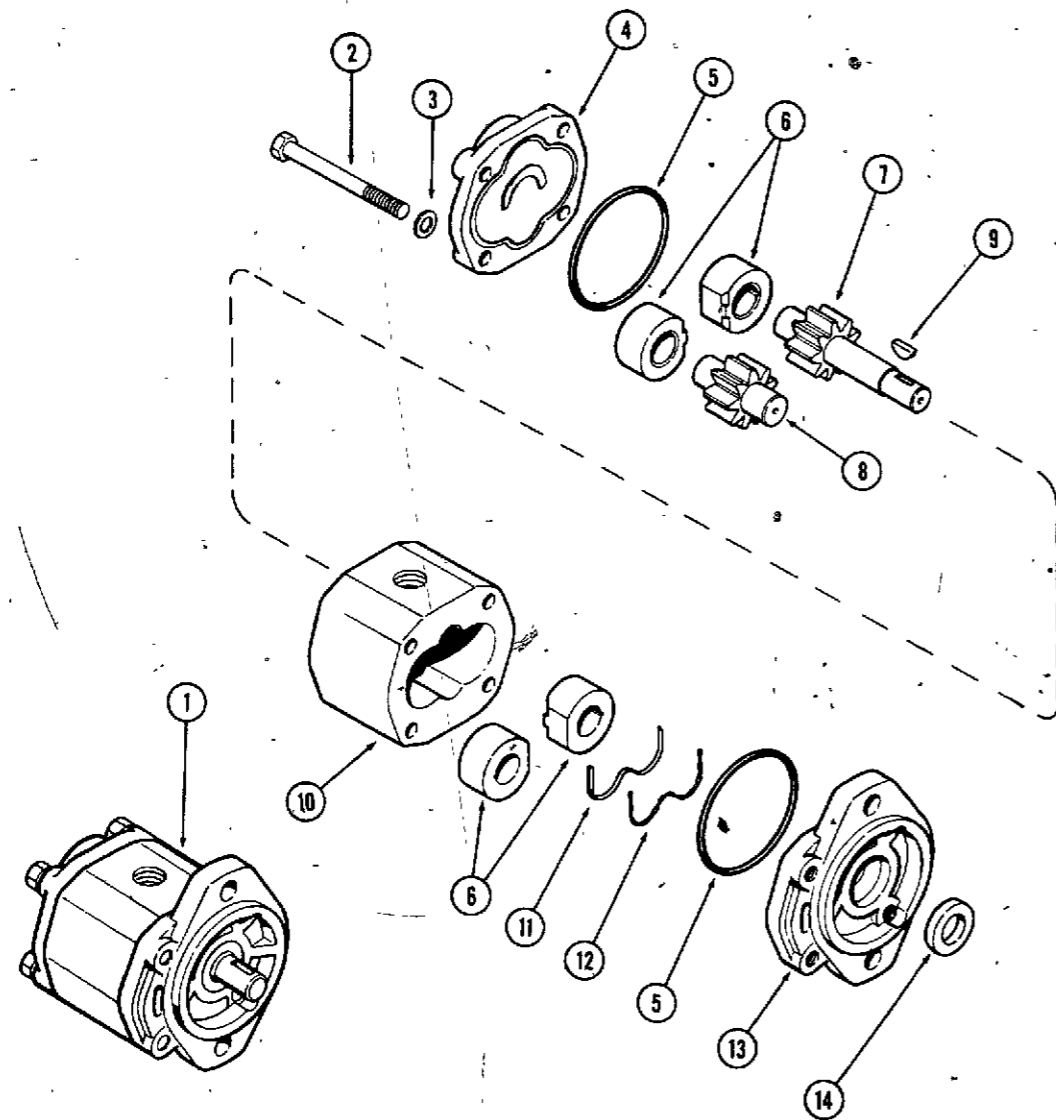

REF. PART NO.	DESCRIPTION	REQ'D
1 C 10493	PUMP - hydraulic (195)	1
1 C 10258	PUMP - hydraulic (155)	1
2 13- 652	BOLT - 3/8" x 3-1/4" N.C. hex head	4
3 A 72000	WASHER - special	4
4 C 11644	COVER - rear, pump body	1
5 A 72003	SEAL - pump cover	2
6 A 35956	BEARING - pump gear	4
7 C 11642	GEAR - pump drive (For C10258 pump on Model 155)	1
7 A 72005	GEAR - pump drive (For C10493 pump on Model 195)	1
8 C 11643	GEAR - pump driven (For C10258 pump on Model 155)	1
8 A 72004	GEAR - pump driven (For C10493 pump on Model 195)	1
9 126- 12	KEY - Woodruff #6	1
10 NSS	BODY - pump (Order C10258 or C10493)	1
11 A 72001	GASKET - brass, front cover	1
12 A 72002	SPACER - gasket, front cover	1
13 A 72007	COVER - front pump body	1
14 G 13827	SEAL - pump shaft	1

PUMP DRIVE COUPLING

18 A 70111	COUPLING - pump drive	1
19 83- 55	SCREW - 5/16" x 5/16" N.C. socket head set	2
20 NSS	HUB - half, 5/8" dia. bore (Order A70111)	1
21 A 70112	SPIDER - coupling	1
22 NSS	HUB - half, 1" dia. bore (Order A70111)	1

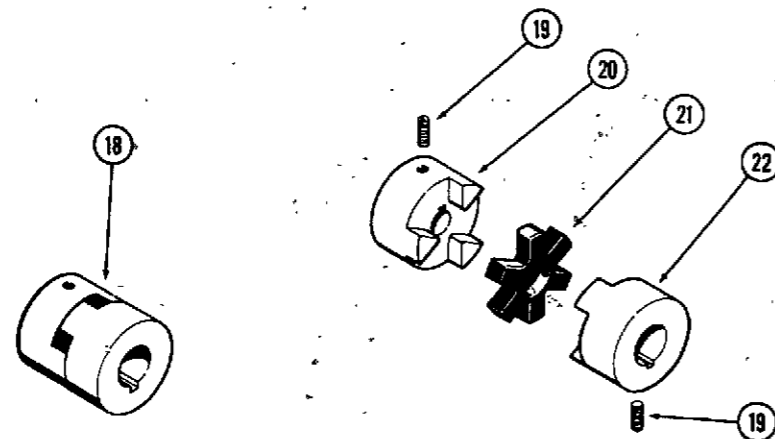

155 HYDRAULIC DRIVE MOTOR

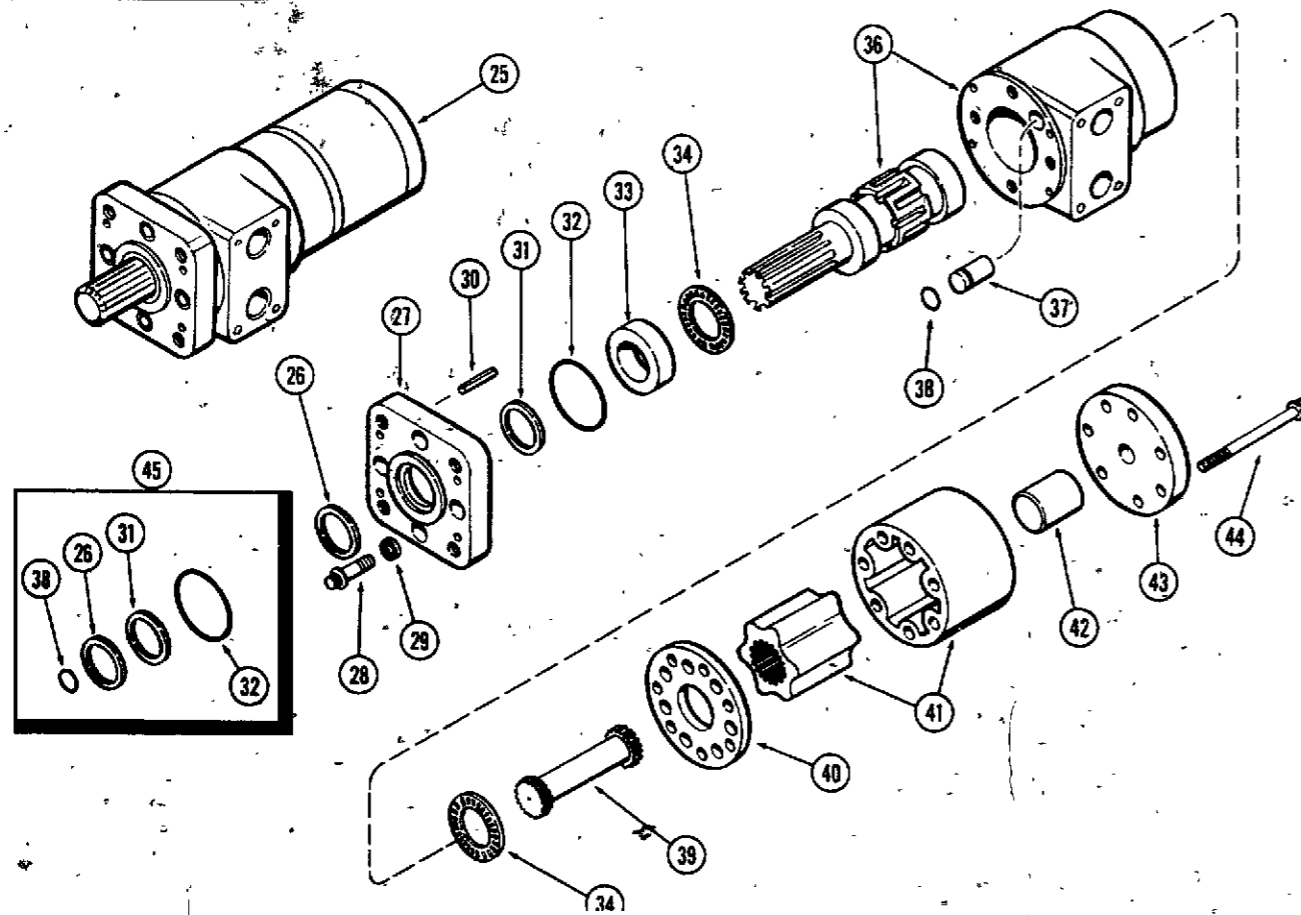
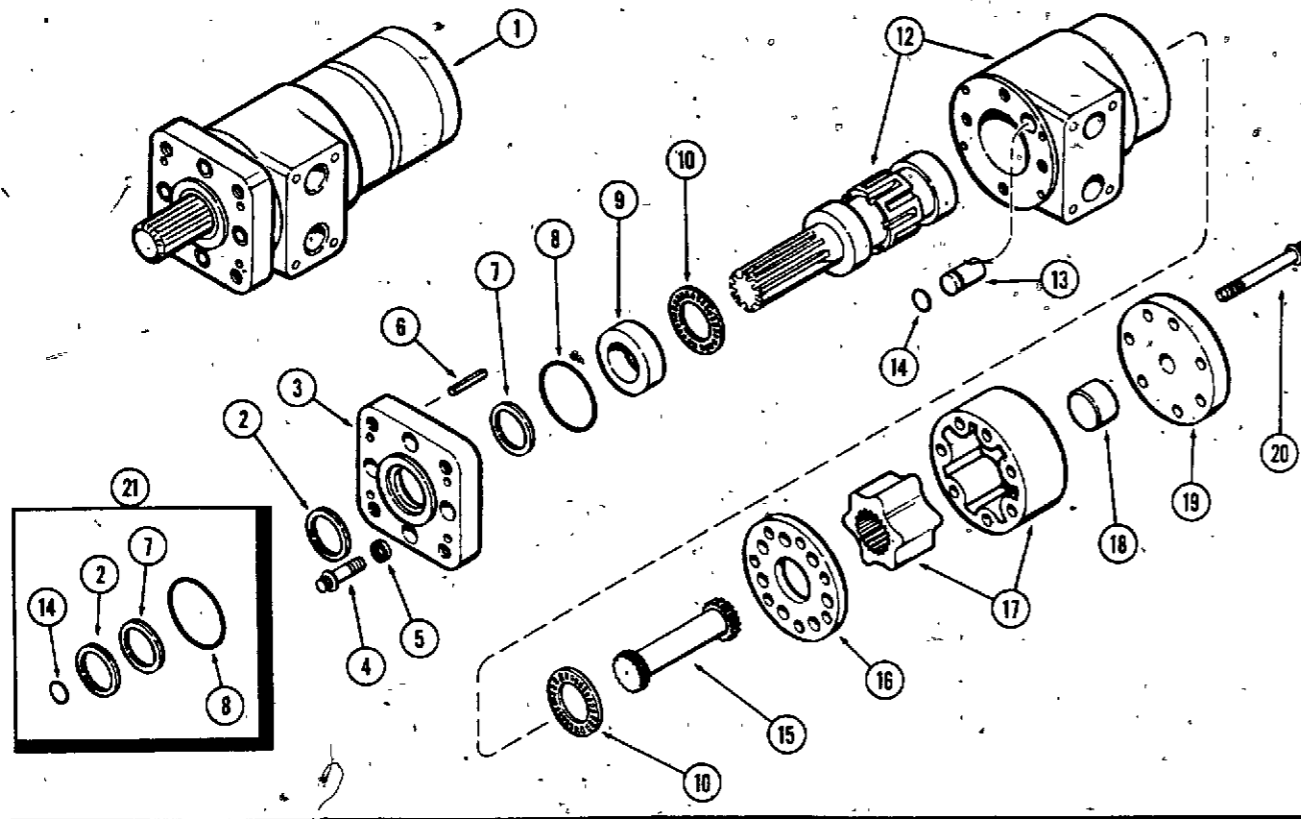

REF. PART NO.	DESCRIPTION	REQ'D
1	C 10271	MOTOR - hydraulic drive (155) . . . . . 1
2*	NSS	OIL SEAL - mtg. plate (See ref. 21) . . . . . 1
3	A 72028	PLATE - mounting . . . . . 1
4	166- 23	CAPSCREW - ferry 5/16" x 5/8" N.C. . . . . 4
5	193- 29	LOCKWASHER - int. shakeproof 5/16" . . . . . 4
6	138- 134	PIN - roll 1/4" x 1" . . . . . 4
7*	NSS	QUAD RING - mtg. plate (See ref. 21) . . . . . 1
8*	NSS	"O" RING - mtg. plate to hsg. (See ref. 21) Case A17528) . . . . . 1
9	A 72030	RACE - output shaft bearing . . . . . 1
10	A 72031	BEARING - thrust, output shaft . . . . . 2
12	C 11645	SHAFT AND HOUSING . . . . . 1
13	A 72034	PLUG - housing . . . . . 1
14*	NSS	"O" RING - hsg. plug (See ref. 21) . . . . . 1
15	A 72027	COUPLING - drive . . . . . 1
16	A 72026	PLATE - spacer . . . . . 1
17	A 72025	GEROTOR SET (1-1/4" thick) . . . . . 1
18	A 72051	SPACER - cplg. drive (3/4" thick) . . . . . 1
19	A 72024	CAP - end . . . . . 1
20	166- 531	CAPSCREW - ferry 5/16" x 2-1/2" N.F. . . . . 7
21	A 72036	KIT - "O" ring and seal (incl. items marked w/*) . . . . . 1

195 HYDRAULIC DRIVE MOTOR

25	C 10270	MOTOR - hydraulic drive (195) . . . . . 1
26*	NSS	OIL SEAL - mtg. plate (See ref. 45) . . . . . 1
27	A 72028	PLATE - mounting . . . . . 1
28	166- 23	CAPSCREW - ferry 5/16" x 5/8" N.C. . . . . 4
29	193- 29	LOCKWASHER - int. shakeproof 5/16" . . . . . 4
30	138- 134	PIN - roll, 1/4" x 1" . . . . . 4
31*	NSS	QUAD RING - mtg. plate (See ref. 45) . . . . . 1
32*	NSS	"O" RING - (See ref. 45) . . . . . 1
33	A 72030	RACE - output shaft bearing . . . . . 1
34	A 72031	BEARING - thrust, output shaft . . . . . 2
36	C 11645	SHAFT AND HOUSING . . . . . 1
37	A 72034	PLUG - housing . . . . . 1
38*	NSS	"O" RING - housing plug (See ref. 45) . . . . . 1
39	A 72027	COUPLING - drive . . . . . 1
40	A 72026	PLATE - spacer . . . . . 1
41	A 72112	GEROTOR SET (2" thick) . . . . . 1
42	A 72113	SPACER - cplg. drv. (1-1/2" thick) . . . . . 1
43	A 72024	CAP - end . . . . . 1
44	166- 532	CAPSCREW - ferry, 5/16" x 3-1/4" N.F. . . . . 7
45	A 72036	KIT - "O" ring and seal (incl. item marked w/*) . . . . . 1

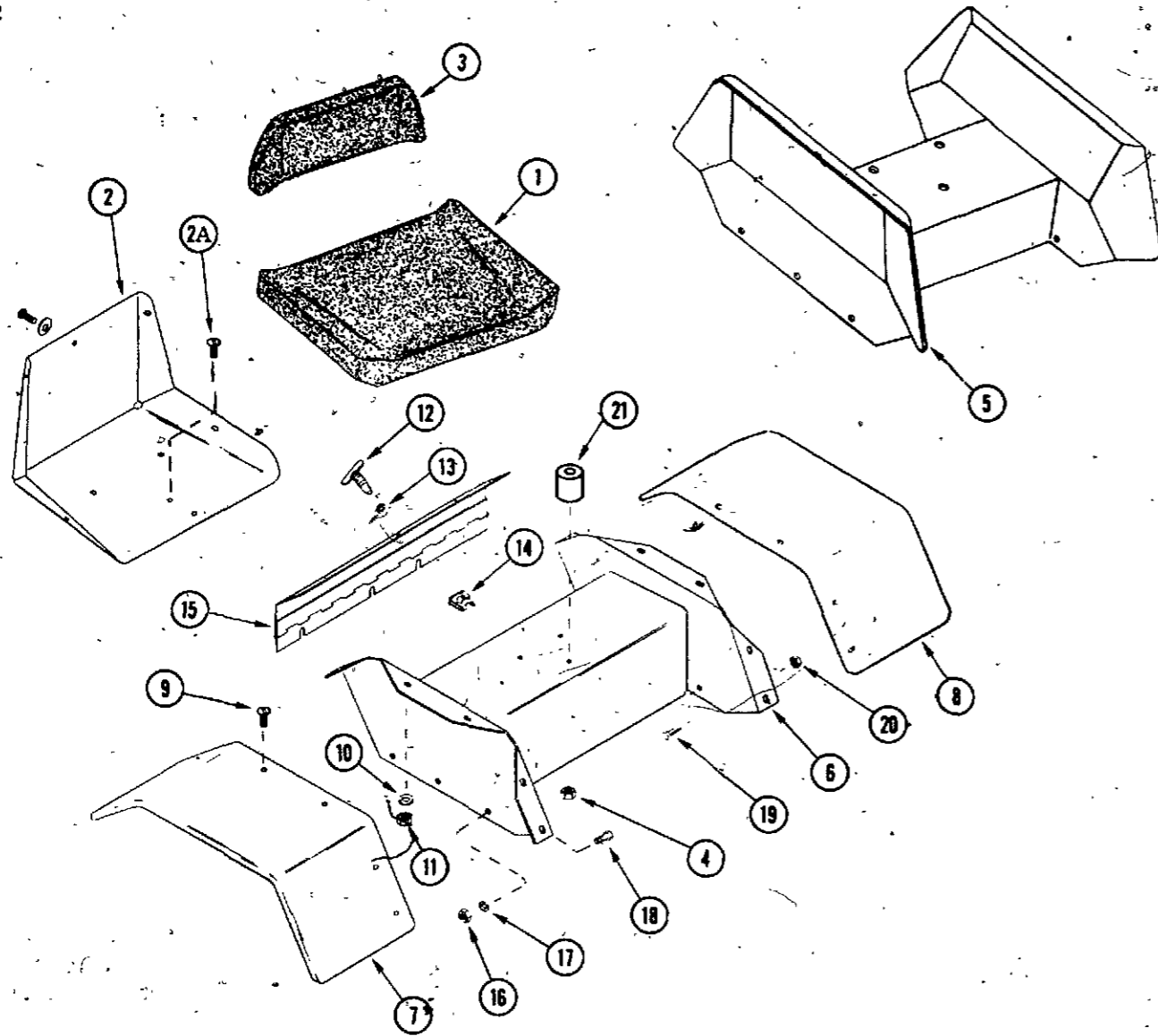

SEAT, FENDERS AND TOOL BOX

REF. PART NO.	DESCRIPTION	REQ'D
C 10421	SEAT ASSEMBLY	1
1 C 11636	CUSHION - seat	1
2 C 11637	PAN - seat	1
2A 111- 207	BOLT - Rd. Hd. Short Sq. Neck, 5/16" x 2" N.C.	3
3 C 11635	CUSHION - back	1
4 131- 351	NUT - 5/16"-18 N.C.	3
5 C 10429	SUPPORT - seat (195)	1
6 C 10380	SUPPORT - seat (155)	1
7 C 10395	FENDER - right hand (155)	1
8 C 10396	FENDER - left hand (155)	1
9 175- 400	SCREW - 1/4"-20 x 1/2" truss head	10
10 192- 19	LOCKWASHER - 1/4" SAE, plated	10
11 129- 101	NUT - 1/4"-20 N.C., fl. head plated	10
12 C 10423	STUD - tool box latch	1
13 C 10489	WASHER - stud retainer	1
14 C 10490	RECEPTACLE - stud clip-on	1
15 C 10424	DOOR - tool box	1
16 129- 102	NUT - 5/8"-18 N.C., fl. hd., plated	5
17 192- 20	LOCKWASHER - 5/16" SAE, plated	5
18 115- 103	BOLT - 5/16"-18 x 3/4" rd. hd., plated	5
19 115- 104	BOLT - 5/16"-18 x 1/2" rd. hd., plated	1
20 131- 176	NUT - 5/16"-18 N.C. Gripco, plated	1
21 C 10433	MOUNTS - seat	3

DECALS

30 C 12180	DECAL - Model 155	2
31 C 12181	DECAL - Model 195	2
32 C 12212	DECAL - instrument panel (large)	1
33 C 12213	DECAL - instrument panel (small)	1
34 A 70233	DECAL - Hi-Lo shift	1
35 C 12276	DECAL - hood stripe, R. H.	1
36 C 12277	DECAL - hood stripe, L. H.	1
37 C 10936	DECAL - PTO ON-OFF	1
38 C 12506	DECAL - level indicator	1

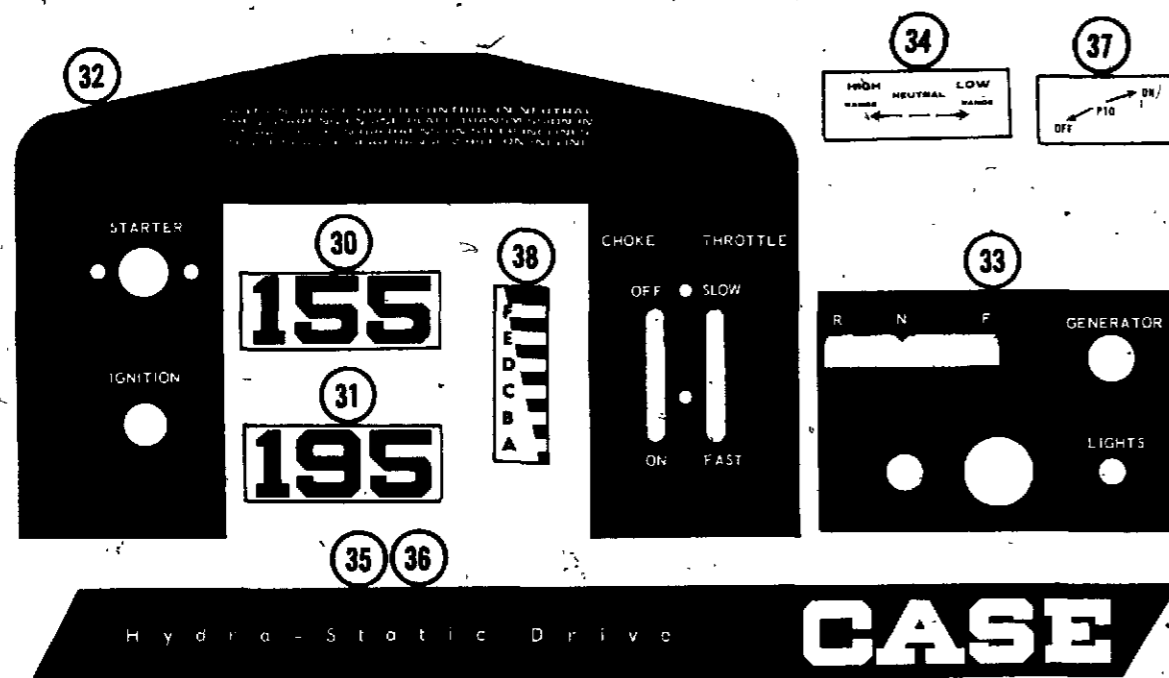

HOOD, FRAME AND GRILLE

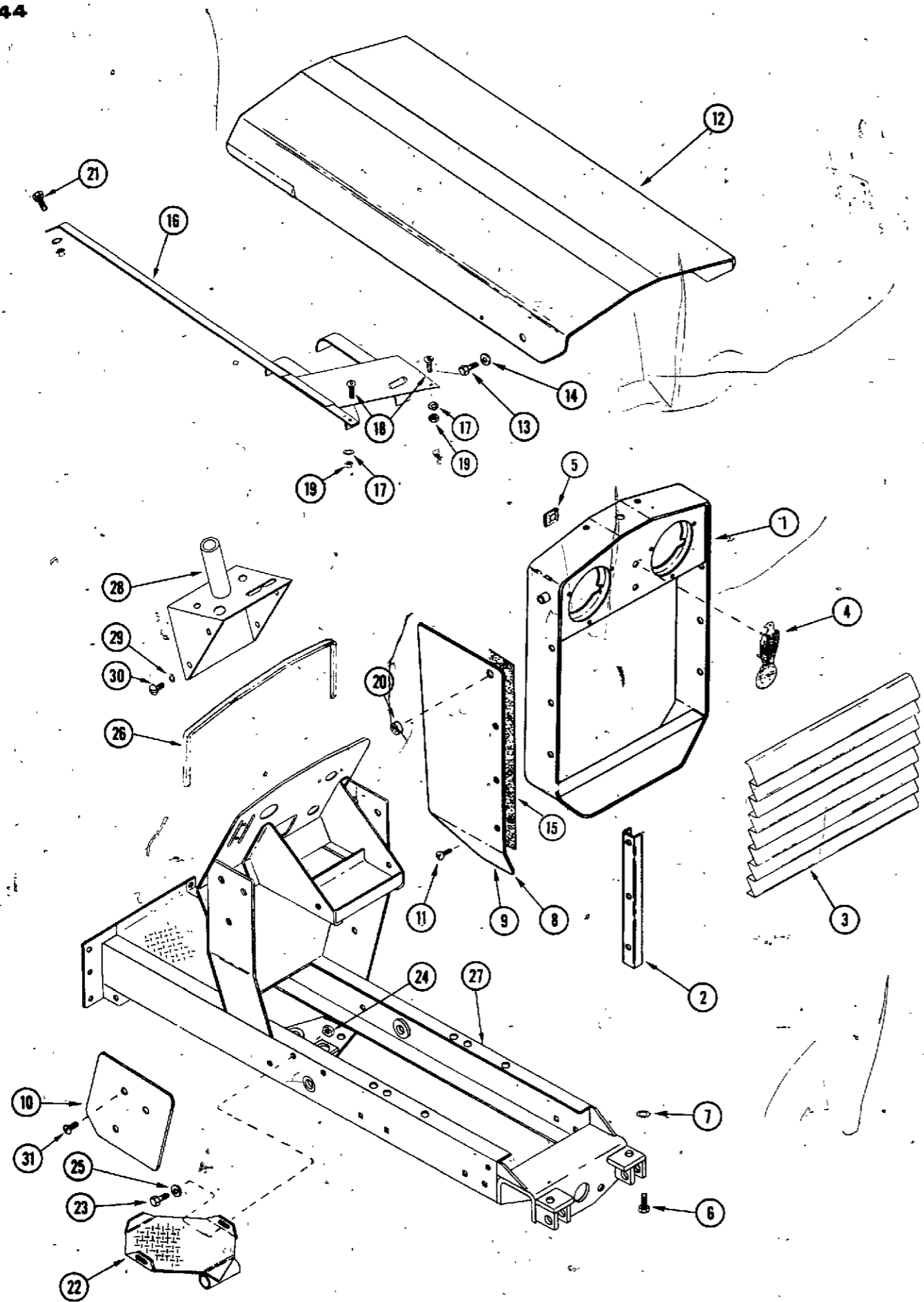

REF. PART NO.	DESCRIPTION	REQ'D
1 C 11295	GRILLE	1
2 C 10349	BRACKET - grille mounting	2
3 C 10413	PANEL - grille	1
4 A 24526	MEDALLION - radiator grille	1
5 131- 138	NUT - 1/4" Timmerman	2
6 182- 509	SCREW - 5/16"-18 x 1" pan head, Phillips	2
7 193- 9	LOCKWASHER - 5/16" SAE external tooth	2
8 C 10370	PANEL - front, side, right hand	1
9 C 10371	PANEL - front, side, left hand	1
10 C 12234	PANEL - rear, side, right hand	2
10 C 12114	PANEL - rear, side, left hand	2
11 C 10596	SCREW - #10 Phillips pan head	6
12 C 10360	HOOD	1
13 C 10361	SCREW - 1/4"-20 x 1/2", lock, plated	2
14 C 11534	BUSHING - hood	2
15 C 12165	WRAPPER - front panel	2
16 C 12203	BRACKET - fuel tank mounting	1
17 193- 8	WASHER - 1/4" shakeproof	3
18 173- 207	SCREW - 1/4" x 5/8" rd. hd. machine	3
19 129- 101	NUT - 1/4" N.C., zinc plated	1
20 C 11533	SPACER - hood	2
21 113- 3	BOLT - 1/4"-20 x 3/4" plated	1
22 C 10283	FOOTPAD	2
23 15- 514	BOLT - 5/16" x 7/8" N.C., rd. hd.	2
24 25- 105	NUT - 5/16"	2
25 92- 5	LOCKWASHER - 5/16" SAE	2
26 C 11582	CHANNEL - instrument panel liner	1
27 C 12047	FRAME - main (195)	1
27 C 12048	FRAME - main (155)	1
28 C 11483	SUPPORT - steering (195)	1
28 C 12057	SUPPORT - steering (155)	1
29 192- 19	LOCKWASHER - 1/4" SAE std. plated	4
30 172- 225	SCREW - 1/4"-20 x 3/8" rd. hd. plated	4
31 187- 1036	SCREW - 1/4"-20 x 1/2" self-tapping	6

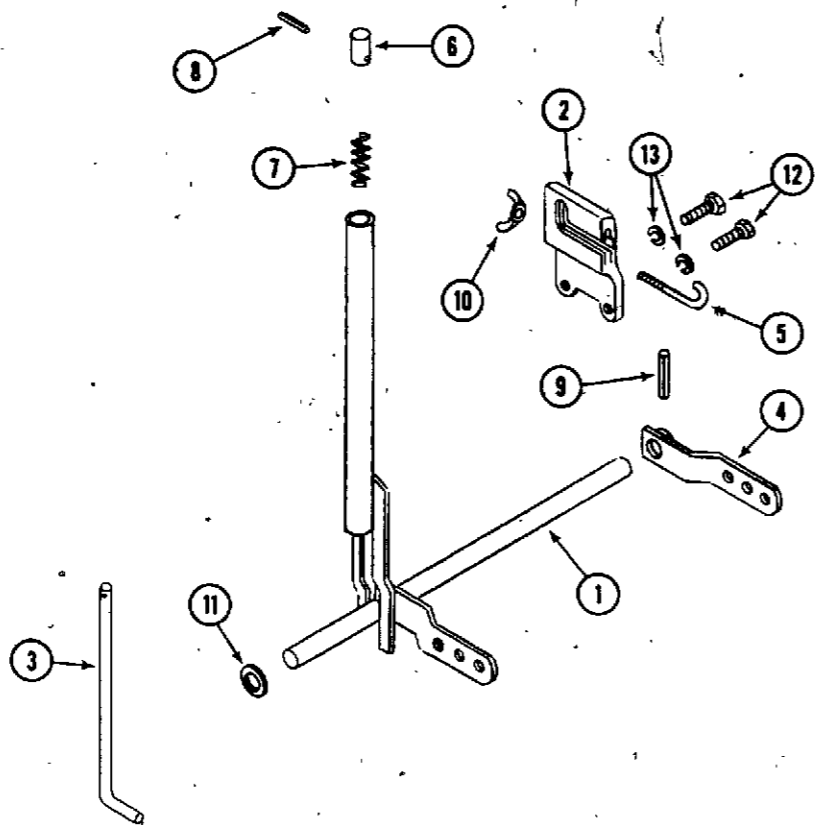

**IMPLEMENT LIFT**

REF. PART NO.	DESCRIPTION	REQ'D
1	C 12570 LEVER - implement lift (includes items 4 and 9)	1
2	C 10336 PAD - lift lever	1
3	C 10338 ROD - lift lever	1
4	NSS LEVER - pivot (use C12570)	1
5	C 12280 ROD - depth adjusting	1
6	C 10356 BUTTON - thumb	1
7	C 10482 SPRING, compression	1
8	C 10485 PIN - spiral, 1/8" x 3/4"	1
9	138- 2033 PIN - spiral, 1/4" x 1-3/8"	1
10	129- 410 NUT - wing	1
11	195- 45 WASHER - 13/16 SAE, plain	1
12	15- 612 BOLT - 3/8"-16 x 3/4" N.C. hex head	2
13	92- 6 LOCKWASHER - 3/8" SAE	2

**DRAWBAR AND TOW HITCH**

15	C 10449	DRAWBAR - hitch	1
16	15- 816	BOLT - 1/2"-13 N.C. x 1"	1
17	92- 8	LOCKWASHER - 1/2" SAE	2
18	15- 824	BOLT - 1/2"-13 N.C. x 2-1/4"	1
19	25- 108	NUT - 1/2"-13 N.C., hex	1

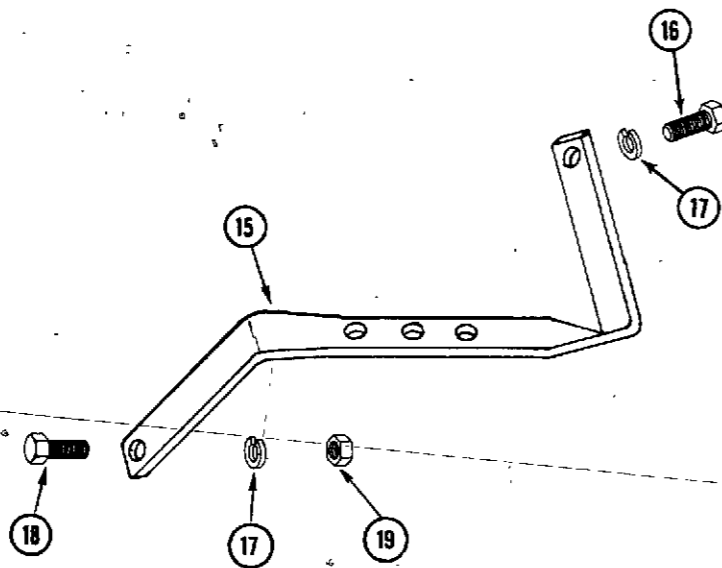



**SPEED CONTROL**

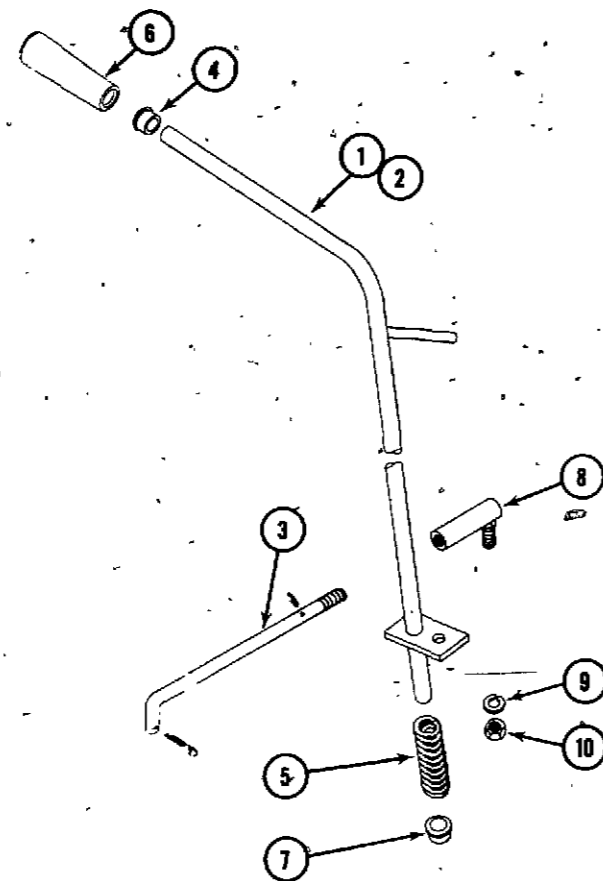

REF. PART NO.	DESCRIPTION	REQ'D
1 C 12208	LEVER - speed control (195)	1
2 C 11907	LEVER - speed control (155)	1
3 C 11943	ROD - speed control	1
4 C 12093	BUSHING - fliplok	1
5 C 11942	SPRING - compression	1
6 A 37247	KNOB - speed control lever	1
7 C 12127	BUSHING - nylon	1
8 C 12168	JOINT - ball	1
9 192- 20	LOCKWASHER - 5/16" std. plated	1
10 129- 102	NUT - 5/16" FHNUNC plated	1

**BRAKE**

20 C 12016	PEDAL - brake	1
21 C 12019	ROD - brake-lock	1
22 132- 26	PIN - cotter, 3/32" x 3/4"	2
23 C 11620	LEVER - brake lock	1
24 131- 352	NUT - 3/8"-16, self-locking	1
25 C 10467	ROD-EYE	1
26 C 11531	ANCHOR, spring	1
27 C 11523	SPRING, extension	1
28 C 10528	VALVE - park and brake	1
29 NSS	SPOOL	1
30 F 62075	"O" RING	3
31 B 18208	SNAP RING	1
32 C 11792	STOP - brake rod	1
33 178- 26	SCREW - set, 1/4" x 3/8" N.C. Cone Pt.	1
34 113- 206	BOLT-3/8 x 3/4 FHBUNC plated	1
35 A 27410	"O" RING - brake valve to hydraulic motor	2

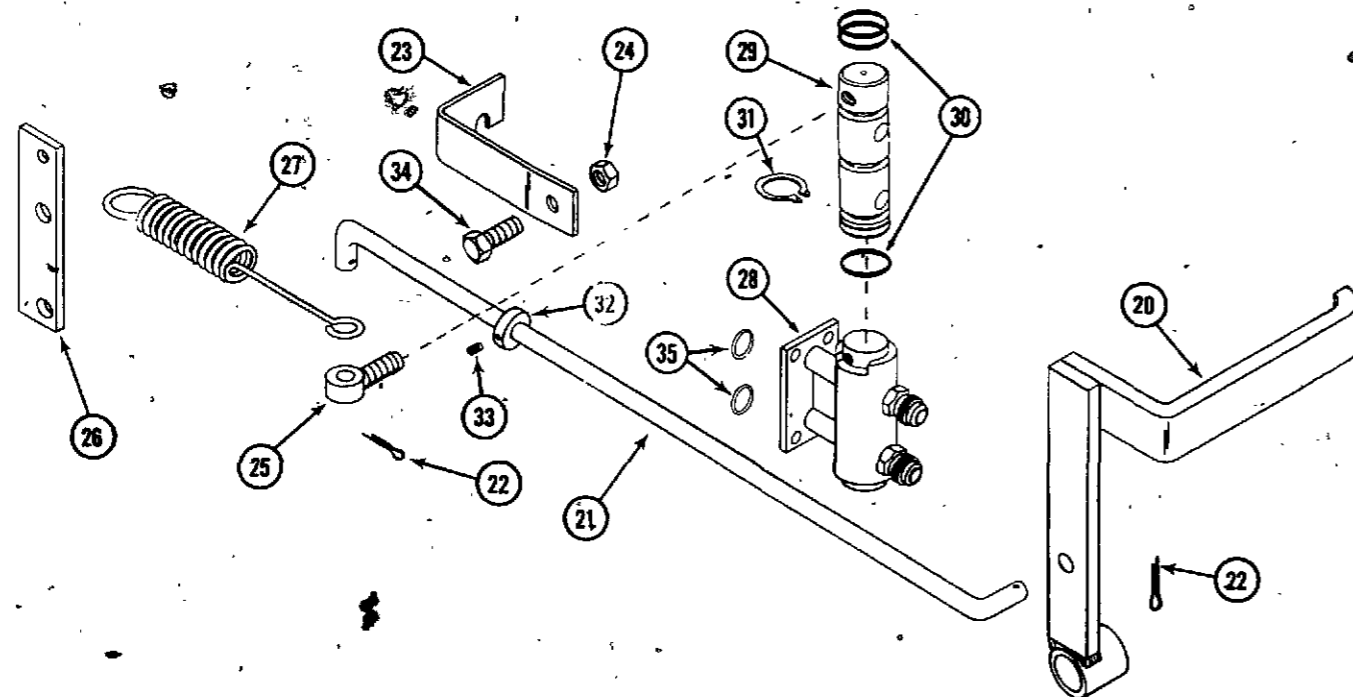

ELECTRICAL WIRING AND HARDWARE

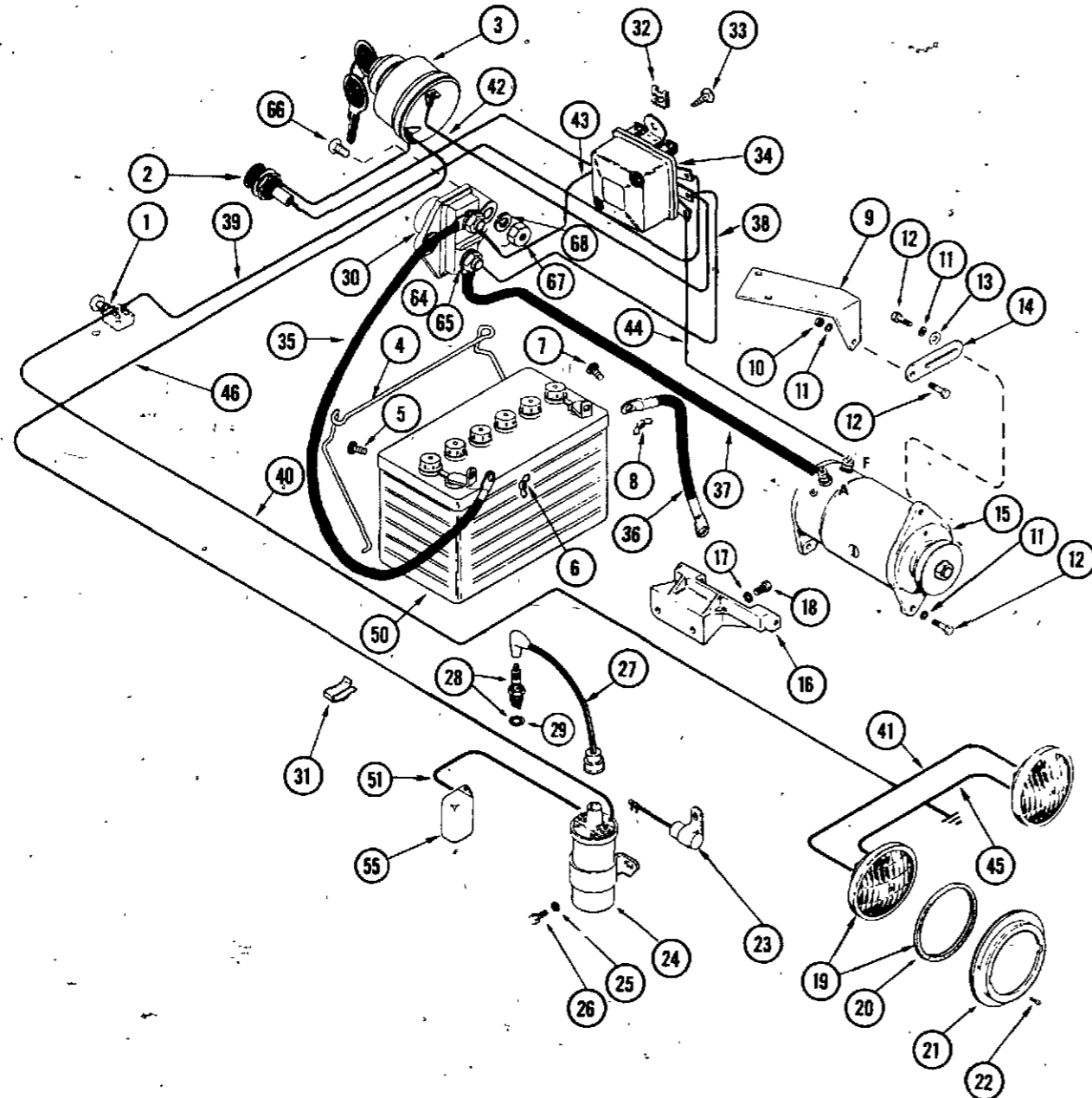

REF. PART NO.	DESCRIPTION	REQ'D
1 C 10474	SWITCH - light	1
2 C 12209	LIGHT - generator indicator (with leads)	1
3 C 11249	SWITCH - ignition (incl. key and nut) Replacement keys not furnished. Must be made locally	1
4 C 10549	STRAP - battery hold-down	1
5 11- 512	BOLT - carriage, battery positive	1
6 129- 419	NUT - wing, battery positive	1
7 11- 412	BOLT - carriage, battery negative	1
8 129- 409	NUT - wing, battery negative	1
9 KO235197	SUPPORT - starter generator adj. bracket	1
10 129- 102	NUT - 5/16" N.C. hex plated	4
11 192- 20	LOCKWASHER - 5/16" SAE std.	5
12 113- 113	BOLT - 5/16" x 1" N.C. hex head plated	3
13 195- 520	WASHER - 5/16" SAE plain	1
14 KO235203	BRACKET - adjusting, starter generator	1
15 A 70202	STARTER-GENERATOR - Delco No. 1101970	1
16 KO235196	SUPPORT - starter generator	1
17 192- 21	LOCKWASHER - 3/8" SAE std. plated	2
18 113- 221	BOLT - 3/8" x 7/8" N.C. hex head plated	2
19 A 11280	HEADLAMP - 12 volt	2
20 A 11276	GASKET - retainer ring	2
21 A 11275	RING - headlamp retainer	2
22 187- 1008	SCREW - #6 x 1/2" pan head self-tapping	6
23 KO230722	CONDENSER	1
24 KO231281	COIL - ignition	1
25 192- 19	LOCKWASHER - 1/4" plated	2
26 113- 1	BOLT - 1/4" x 1/2" N.C. hex head plated	2
27 KOA235095	CABLE - high tension	1
28 M 20007	SPARK PLUG - (includes gasket)	1
29 A 27251	GASKET - spark plug	1
30 C 11247	SWITCH - starter	1
31 C 10472	CLIP - wire holder	2
32 C 10836	NUT - speed type "U"	2
33 187- 131	SCREW - #10 x 1/2" flat head self-tapping	2

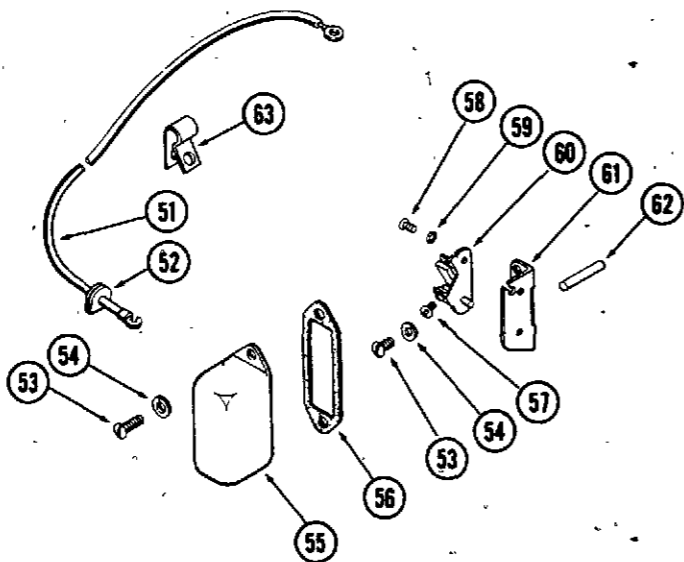
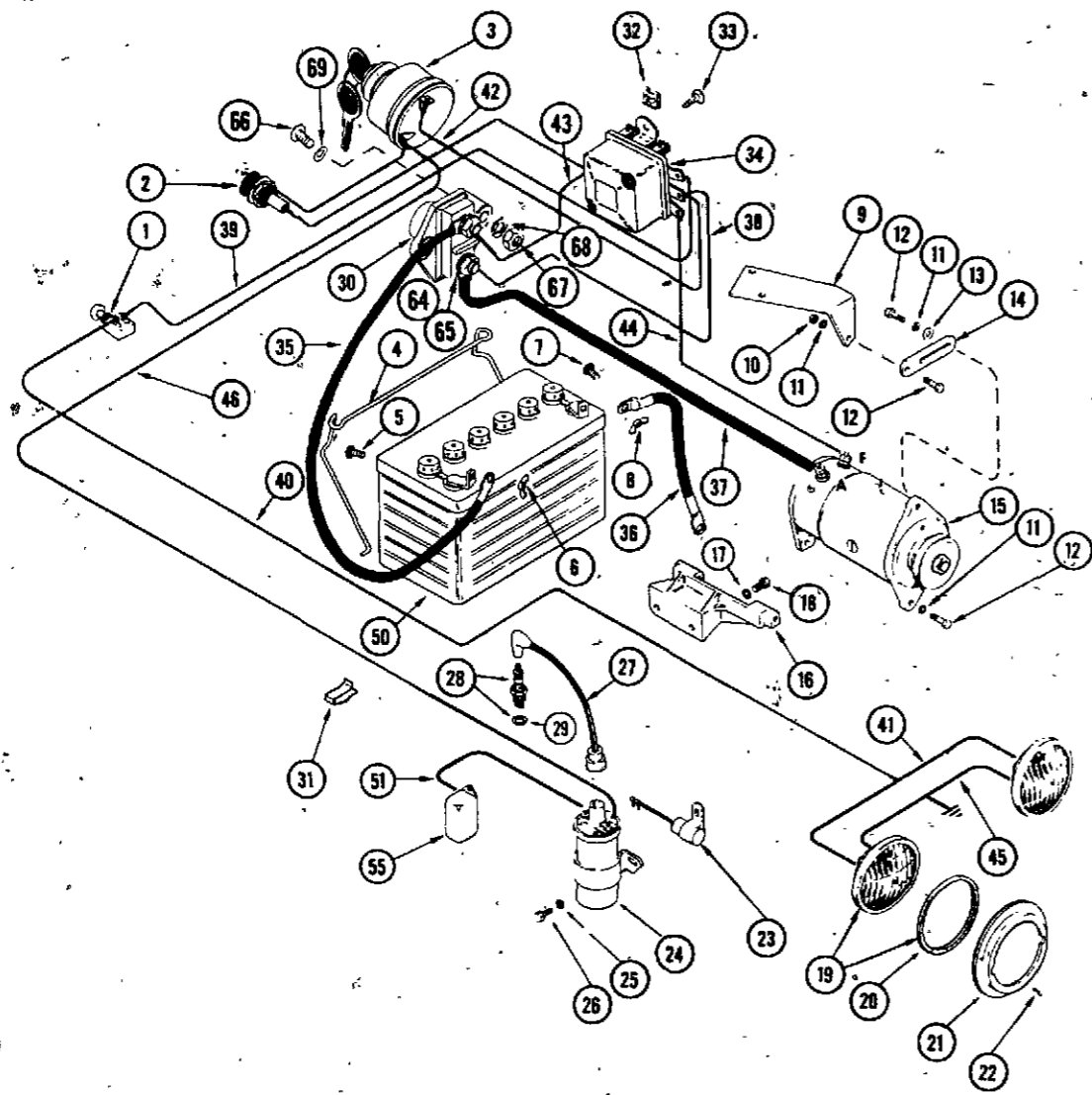

**ELECTRICAL WIRING AND HARDWARE**

REF. PART NO.	DESCRIPTION	REQ'D.
34 A 70221	REGULATOR - voltage, Delco No. 1118988	1
35 C 12197	CABLE - battery to starter button	1
36 C 12198	CABLE - battery to ground	1
37 C 12199	CABLE - starter button to generator	1
38 C 12193	WIRE - regulator ground to starter button, white, 12"	1
39 C 12194	WIRE - regulator to light switch, yellow, 19"	1
40 C 12269	WIRE - connector to lights, black	1
41 C 12270	WIRE - lights to connector	1
42 C 12195	WIRE - ignition switch to regulator, red, 8-3/4"	1
43 C 12196	WIRE - regulator to starter button, black, 13"	1
44 C 12192	WIRE - regulator to generator, black, 17"	1
45 C 10985	WIRE ASSEMBLY - headlight to ground	1
46 C 10592	WIRE - ignition switch to coil, green, 36"	1
50 M 20164	BATTERY - 12 volt	1
51 KOA231533	LEAD - breaker contact (includes grommet)	1
52 KO 220297	GROMMET - breaker contact lead	1
53 173- 210	SCREW - #10-24 x 3/8" rd. hd. plated	4
54 192- 18	LOCKWASHER - 3/16" plated	4
55 KO 232535	COVER - breaker contact	1
56 KO 220174	GASKET - cover, breaker contact	1
57 187- 408	SCREW - terminal, #6-32 x 3/8" self-tapping	1
58 173- 224	SCREW - breaker contact mtg. #8 x 1/4" N.C. rd. hd.	1
59 193- 5	LOCKWASHER - #8 internal shakeproof	1
60 KO 220475	POINT SET - breaker contact	1
61 KO 220476	BRACKET - mounting breaker contacts	1
62 KOX389-1	ROD - breaker contact push	1
63 KO 275303	CLIP - breaker contact wire	1
64 124- 102	NUT - FHNUNC 5/16 plated	2
65 192- 20	LOCKWASHER - 5/16 SAE std. plated	2
66 175- 403	SCREW - 1/4" N.C. x 3/4" truss head plated	2
67 129- 101	NUT - 1/4" FHNUNC plated	2
68 192- 19	LOCKWASHER - 1/4" plated	2
69 195- 517	WASHER - plain 1/4" plated	1

**D8 WHEEL WEIGHTS - MODEL 155**

REF. PART NO.	DESCRIPTION	REQ'D
1 NSS	WEIGHT - wheel, 12" (order as machinery item) . . . . .	4
2 111- 532	BOLT - carriage, 1/2" x 3-3/4" plated . . . . .	8
3 192- 23	LOCKWASHER - 1/2" SAE std. plated . . . . .	8
4 129- 105	NUT - FHNUNC 1/2"-13" plated . . . . .	8

**D10 WHEEL WEIGHTS - MODEL 195**

REF. PART NO.	DESCRIPTION	REQ'D
10 NSS	WEIGHT - wheel, 15" & 16" (order as machinery item) . . . . .	4
11 111- 530	BOLT - carriage, 1/2"-13 x 2-1/2" plated . . . . .	4
12 111- 531	BOLT - carriage, 1/2"-13 x 2-3/4" plated . . . . .	4
13 92- 8	LOCKWASHER - 1/2" SAE std. plated . . . . .	8
14 129- 105	NUT - FHNUNC 1/2"-13" plated . . . . .	8

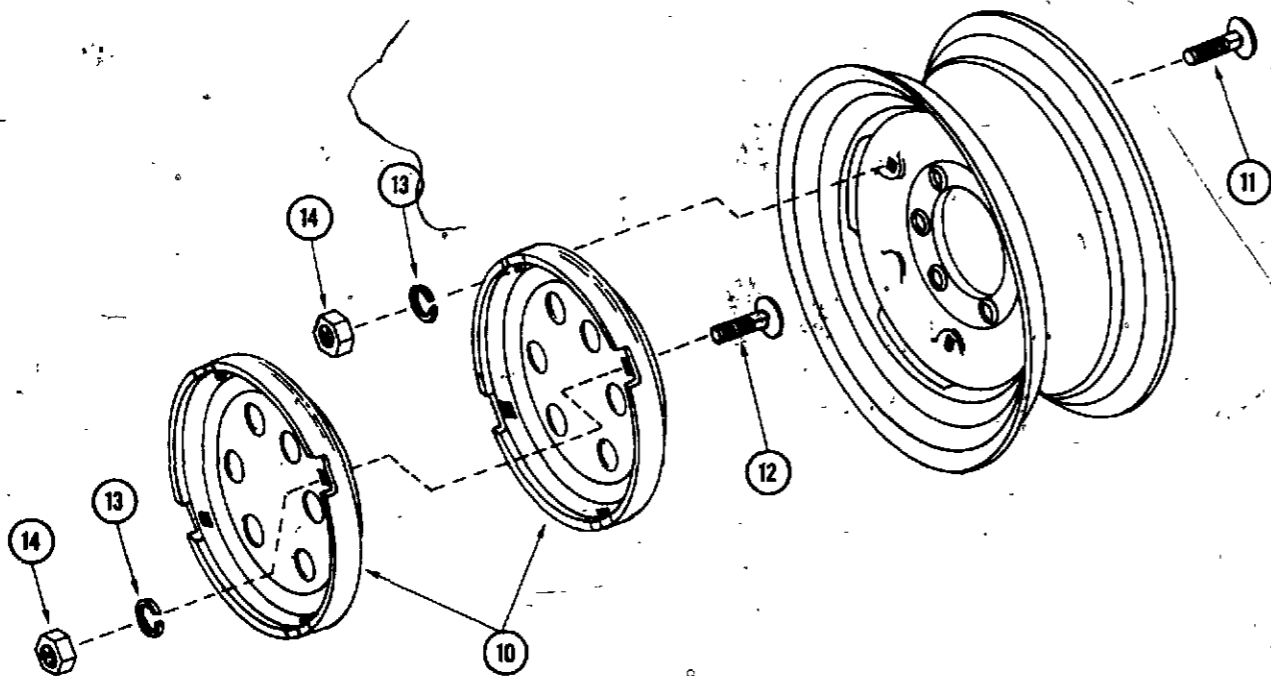
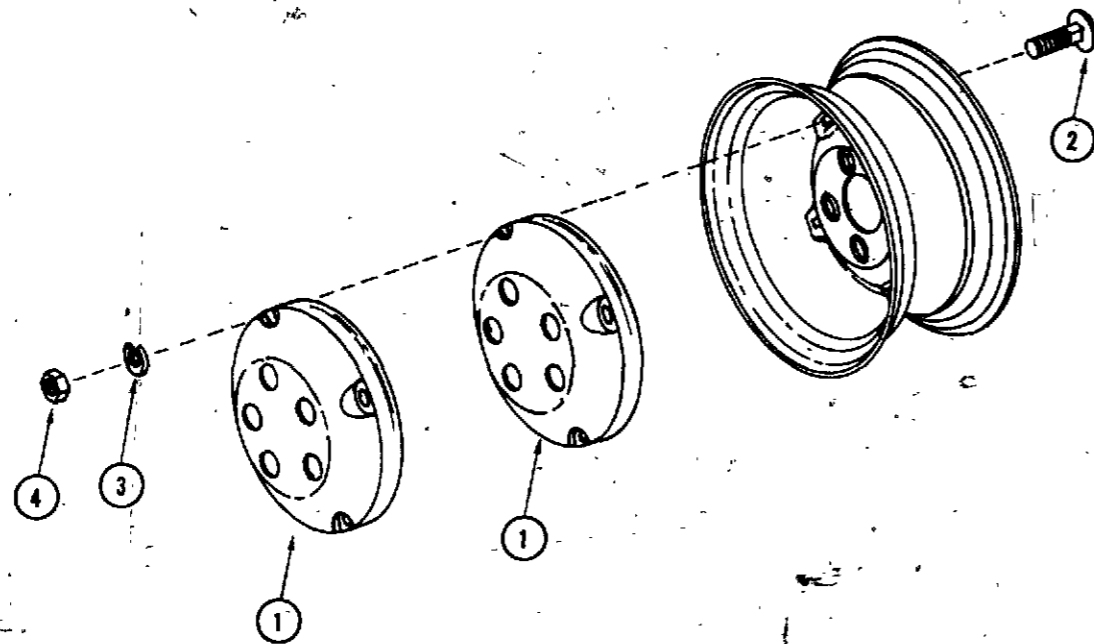





## NUMERICAL INDEX

PART NO.	PAGE NO.	REF. NO.	PART NO.	PAGE NO.	REF. NO.	PART NO.	PAGE NO.	REF. NO.
192- 18	5	8	211- 3	21	4			
192- 18	17	39	214- 101	23	16			
192- 18	17	54	214- 253	19	9			
192- 18	53	54	218- 445	35	18			
192- 18	25	28	218- 493	35	3*			
192- 19	13	18	218- 494	35	12			
192- 19	15	18	218- 1056	35	22			
192- 19	17	2	218- 5006	35	23			
192- 19	17	9	218- 5008	35	25			
192- 19	17	13	218- 5059	35	24			
192- 19	17	46	218- 5106	35	3**			
192- 19	43	10	218- 5108	35	10			
192- 19	45	29	219- 1	31	4			
192- 19	51	25	219- 1	31	14			
192- 19	53	68	219- 8	29	14			
192- 20	19	12	219- 8	29	31			
192- 20	23	8	221- 2	13	26			
192- 20	43	17	221- 2	15	26			
192- 20	49	9	221- 4	33	10			
192- 20	51	11	222- 41	19	20			
192- 20	53	65	222- 101	19	21			
192- 21	13	15	222- 112	19	22			
192- 21	13	24	222- 4021	19	24			
192- 21	13	32	40035	9	20			
192- 21	13	39	40035	11	20			
192- 21	15	15	40035	13	28			
192- 21	15	24	40035	15	28			
192- 21	15	32						
192- 21	15	39						
192- 21	17	19						
192- 21	23	9						
192- 21	29	16						
192- 21	29	33						
192- 21	35	33						
192- 21	51	17						
192- 23	55	3						
192- 26	25	35						
193- 5	53	59						
193- 8	45	17						
193- 9	45	7						
193- 29	35	6						
193- 29	41	5						
193- 29	41	29						
193- 31	35	27						
193- 52	35	37						
193- 60	5	20						
193- 60	19	19						
195- 45	47	11						
195- 104	17	18						
195- 512	5	9						
195- 515	17	8						
195- 515	17	43						
195- 517	23	10						
195- 517	53	69						
195- 520	51	13						
195- 522	23	11						
195- 545	13	36						
195- 545	15	36						
195-2082	27	13						
205- 27	13	30						
205- 27	15	30						

# INGERSOLL

Ingersoll Equipment Co., Inc.