



Ingersoll

**Front Cut Attachments
Parts and Operators Manual
Catalog 8-59960
BC14 Cab**

HOME

ATTACHMENTS

ALPHABETICAL INDEX

Contents	1
Steps 1 and 2,.....	2
Step 3	3
Step 4	4
Step 5	5
Step 6	6
Step 7	7
Step 8, 9	8
Step 10,11	9
Step 12, 13	10
Step 14	11

CAB MODEL BC14

FOR INGERSOLL 5000 SERIES, GRAZER GROUNDS MOWER, M&W LAWN CLIPPER, AND WHITE TURF BOSS

THIS CAB IS FOR UNITS WITH TAIL PIPE EXHAUST ONLY. DO NOT
INSTALL ON ANY UNIT THAT HAS A SIDE DISCHARGE EXHAUST SYSTEM.

CARTON CONTENTS

KEY#	PART #	QTY	DESCRIPTION
1	10511	1	WINDSHIELD SUPPORT, upper
2	10544	1	WINDSHIELD SUPPORT, lower
3	10517	1	BACKING PLATE, 4 hole
4	10545	1	BACKING PLATE, 2 hole
5	10514	1	FRONT FOOT
6	10512	1	REAR BRACKET, right
7	10513	1	REAR BRACKET, left
8	10515	1	REAR BRACE
9	10304	1	FRONT POST
10	10516	1	REAR POST, right (w/o latch)
11	10034	1	REAR POST, left
12	10522	1	RIGHT PANEL SUPPORT, rear
13	10523	1	RIGHT PANEL SUPPORT, front
14	10524	1	RIGHT PANEL SUPPORT, lower
15	10198	1	REAR BOXING POST, right
16	10199	1	REAR BOXING POST, left
17	10001	1	TOP FRAME
18	10521	1	UPPER BRACE
19	10305	1	WINDSHIELD
20	10518	1	FRONT BRACE
21	10529-B	1	FRONT PANEL VINYL
22	10528-B	1	REAR CURTAIN
23	10526-B	1	RIGHT PANEL
24	10527-B	1	DOOR
25	10534	1	DOOR BOTTOM
26	10000	1	PLASTIC TOP
27	09510	1	WINDSHIELD WIPER KIT
28	10525	1	HARDWARE PACKAGE
	0926	2	1/4"-20 x 1" CAPSCREW, hex
	0788	18	1/4"-20 x 3/4" CAPSCREW, hex
	0786	2	1/4"-20 X 5/8" CAPSCREW, hex
	0730	22	1/4"-20 LOCKNUT
	3951	3	1/4" FLAT WASHER
	6654	2	1/4"-20 X 1 3/4" CAPSCREW, hex
	0908	1	1/4"-20 X 1 1/2" CAPSCREW, hex
	0785	5	5/16"-18 X 1" CAPSCREW, hex
	0729	5	5/16"-18 LOCKNUT
	6772	3	3/8"-16 X 1" CAPSCREW, hex
	0790	3	3/8"-16 LOCKNUT
	0317	2	5/16" FLATWASHER
	0007	1	5/16" LOCKWASHER
	7227	1	1/2" O.D. X 1/4" SPACER
	9625	2	1/2"-13 X 2" CAPSCREW, hex
	9626	2	1/2"-13 NYLOCK NUT
	9627	2	1/2" FENDER WASHER
	9628	2	RUBBER BODY MOUNT
	4902	2	PLASTIC PROTECTOR
	0015	2	DOOR HINGE

INDEX

READ THESE INSTRUCTIONS COMPLETELY BEFORE BEGINNING INSTALLATION.

THE RIGHT SIDE OF THE TRACTOR IS DETERMINED AS BEING SEATED IN THE OPERATORS POSITION.

IN THESE INSTRUCTIONS "BOLT" MEANS 1/4-20" X 3/4" BOLT AND "NUT" MEANS 1/4" LOCKNUT, UNLESS SPECIFIED OTHERWISE.

SET ASIDE THE 1/4" X 1" AND THE 1/4" X 5/8" BOLTS SO THAT THEY WILL NOT BE USED IN THE WRONG LOCATION.

STEP 1; SEE FIGURE 1:

A. Identify all of the steel parts using FIGURE 1 as an example.

FIGURE 1

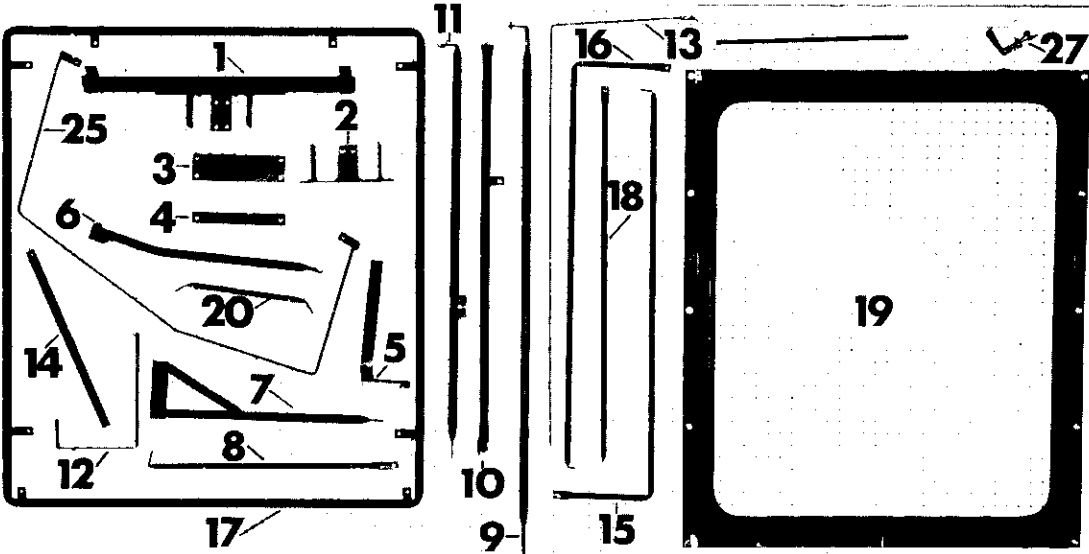

STEP 2; SEE FIGURE 2:

- A. Place the drilling template from the back of this manual, on the control tower. Align the side of the page with the bottom edge of the tower. Then align the lines on the page with the folds on the sides of the tower.
- B. Use a center punch to mark the holes. Drill 13/32" holes through the tower.

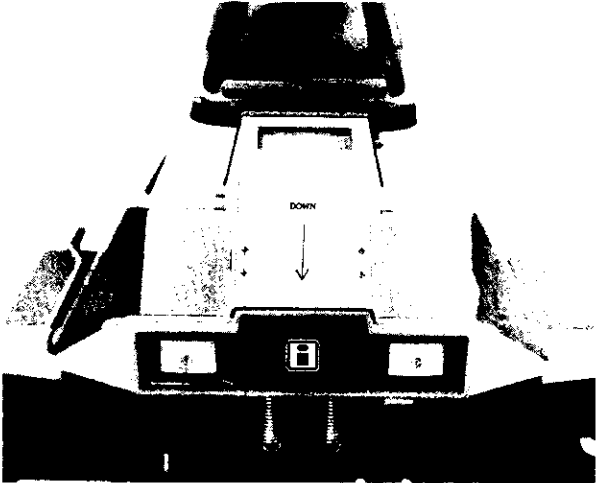

FIGURE 2

INDEX

STEP 3; SEE FIGURE 3:

NOTE: Measure the distance from the bottom of the foot rests to the front of the control tower. Some models have a 12" tower, other models have a 10" tower.

Models with the 12" tower must have the windshield support assembled in the short position. Models with a 10" control tower must be assembled in the tall position.

- A. Use three $\frac{3}{8}$ " x 1" bolts and locknuts to assemble the UPPER WINDSHIELD SUPPORT (1) to the LOWER WINDSHIELD SUPPORT (2) in the proper position for your machine.

NOTE: To complete step 3B below you must determine which backing plate to use. Manual lift models require the 4 hole backing plate. Hydraulic lift models require the 2 hole backing plate.

- B. Place the backing plate under the control tower. Insert four $\frac{5}{16}$ " x 1" bolts up through the holes. Place the assembled windshield support over the bolts add $\frac{5}{16}$ " locknuts and tighten.
- C. Remove the body mount bolt at REFERENCE A. Place the FRONT FOOT (5) over the hole on top of the washer and rubber mount. Replace the bolt and tighten.

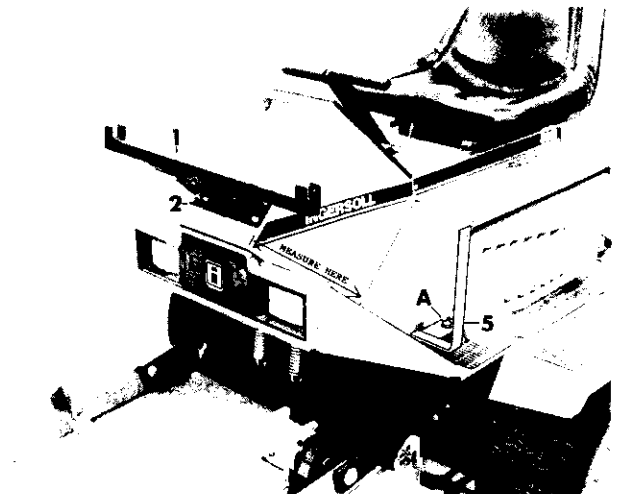

FIGURE 3

STEP 4; SEE FIGURE 4:**FOR DIESEL MODELS ONLY**

- A. To mount the REAR BRACKETS (6 & 7) a $\frac{1}{2}$ " hole must be drilled $26\frac{1}{2}$ " behind the front body mounts and $1\frac{3}{4}$ " out from the engine compartment. Use the large washers, rubber mounts $1\frac{1}{2}$ " x 2" bolts and $\frac{1}{2}$ " nylock nuts to attach the rear brackets to the machine.
- B. To mount the REAR BRACE (8) drill an $\frac{11}{32}$ " hole 4" forward of the $\frac{1}{2}$ " hole and just inside the edge of the body. (SEE STEP 6)
- C. Follow the instructions for gasoline units to attach remaining parts.

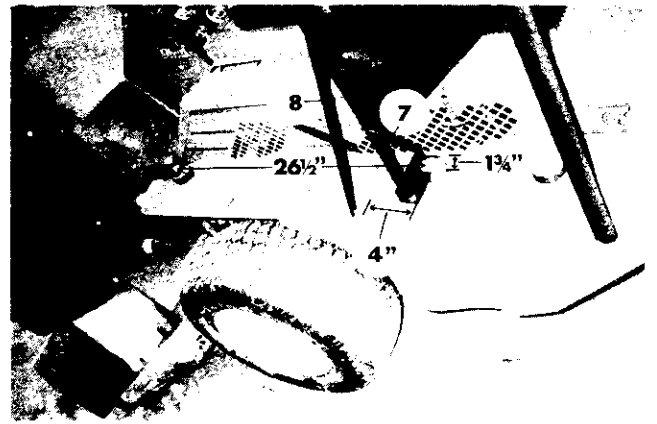

FIGURE 4

FOR DIESEL MODELS ONLY

STEP 5; SEE FIGURE 5:**FOR GAS MODELS:**

Remove the body mount bolt at REFERENCE B. Place the right REAR BRACKET (6) on the mount replace the bolt and tighten.

- B. Assemble the two halves of the RIGHT PANEL SUPPORT (12 & 13) with two bolts inserted outwards and two locknuts.
- C. Insert a 1/4" x 1" bolt outwards through the lower end of the right REAR BOXING POST (15), the upper end of the right REAR BRACKET (6) the lower end of the right REAR POST (10), and then the rear of the assembled RIGHT PANEL SUPPORT. Add a nut.

NOTE: FOR DIESEL MODELS; The lower tab on the exhaust pipe will go between parts 10 and 12.

- D. Insert a 1/4" x 1 3/4" bolt through the forward end of right panel support and tabs on the windshield support to hold it in place. Tighten the 1" bolt keeping the posts vertical.
- E. Fasten the lower RIGHT PANEL SUPPORT (14) to the rear right panel support with a bolt and nut.

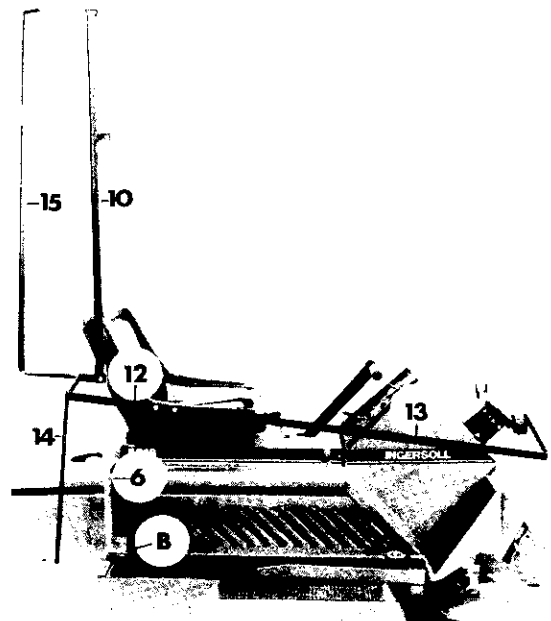

FIGURE 5

STEP 6; SEE FIGURE 6:**FOR GAS MODELS:**

- A. Remove the body mount bolt at REFERENCE C. Place the left REAR BRACKET (7) on the body mount, replace the bolt and tighten the nut.
- B. Remove the bolt at REFERENCE D. Place two $\frac{5}{16}$ " flat washers over the hole and then the bent end of the REAR BRACE (8). Insert a $\frac{5}{16}$ " x 1" bolt with a $\frac{5}{16}$ " lockwasher into the hole do not tighten yet. (Add a $\frac{5}{16}$ " locknut for models with drilled hole.)

NOTE: See instructions for step 4B for drilling hole for brace in some gasoline models.

- C. Insert a $\frac{1}{4}$ " x $1\frac{1}{2}$ " bolt through the upper end of the rear brace. Place a $\frac{1}{2}$ " x $\frac{1}{4}$ " spacer over the bolt. Insert the bolt through the left REAR BOXING POST (16), the upper end of the REAR BRACKET (7) and then the left REAR POST (11).
- D. Add a nut and tighten the bolt keeping the posts vertical. Tighten the bolt that holds the rear brace to the machine.

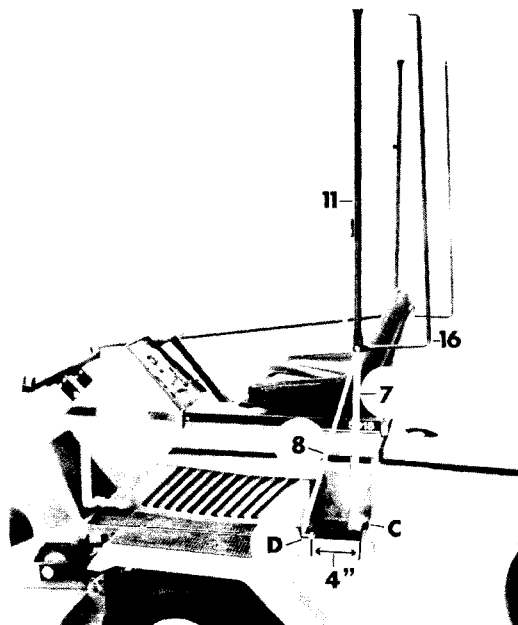

FIGURE 6

INDEX

STEP 7; SEE FIGURE 7:

- A. Insert a bolt through the least bent end of the FRONT BRACE (20). Insert the bolt through the FRONT FOOT (5) and then the lower end of the FRONT POST (9). Add a nut.
- B. Insert a $\frac{1}{4}$ " x $1\frac{3}{4}$ " bolt through the other end of the front brace and the tabs welded to the windshield support to hold it in position. Tighten the bolt from step 7A to keep the front post vertical.
- C. Use a bolt and nut to fasten a door hinge to the second hole from the bottom of the front post. (see inset)
- D. Place the TOP FRAME (17) onto the bent ends of the posts. Insert 5 bolts upwards add nuts do not tighten yet.
- E. Use two bolts and nuts to attach the UPPER BRACE (18) to the welded tab on the right rear post and the tab on the top frame.

Place a plastic protector over the bent ends of each rear post. (see inset)

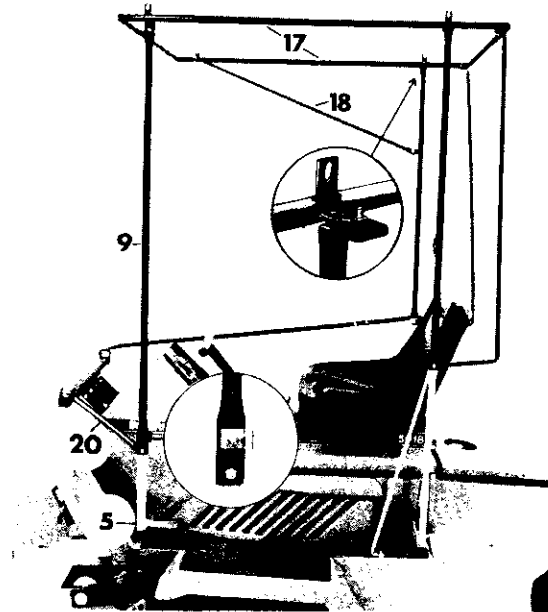

FIGURE 7

STEP 8; SEE FIGURE 8:

- A. Remove both 1/4" x 1 3/4" bolts from the windshield support.
- B. Set the WINDSHIELD (19) into the windshield support. Line up the welded tabs on the top frame with the tabs on the windshield. Insert two bolts upwards and add nuts.
- C. Insert a 1/4" x 1 3/4" bolt through the front brace and then the windshield and windshield support on the left side, add a nut.
- D. On the right side insert another 1/4" x 1 3/4" bolt through the windshield and windshield support. Place the forward end of the right panel support over the bolt. Add a nut and tighten these two bolts and all of the bolts that hold the top frame in place.

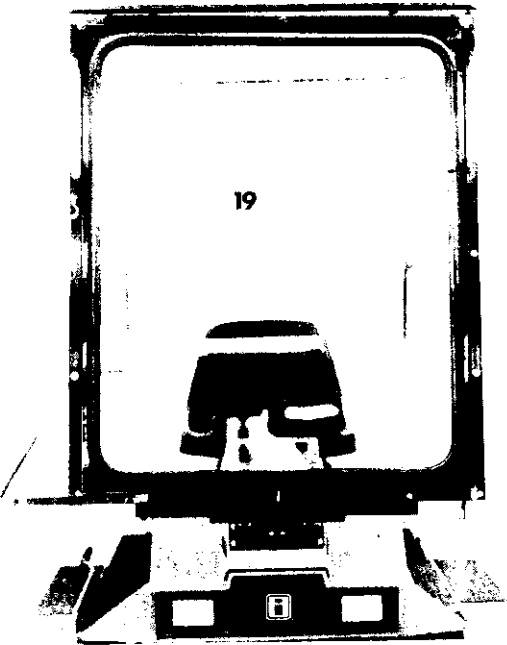

FIGURE 8

STEP 9; SEE FIGURE 9:

- A. Snap the FRONT PANEL VINYL (21) to the windshield. Close the snap flaps around the top frame, front post and front foot. Snap the center piece to the windshield support.

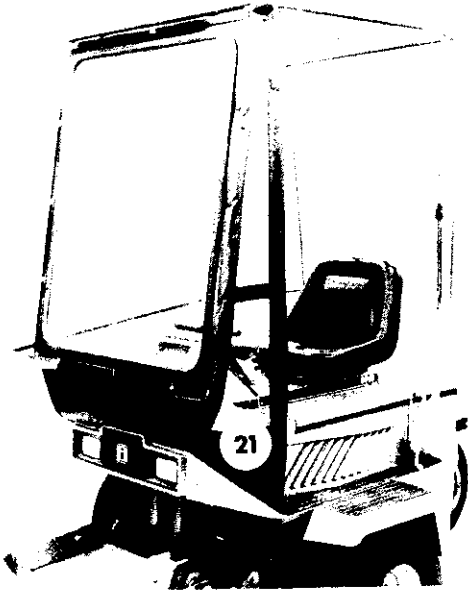

FIGURE 9

STEP 10; SEE FIGURE 10:

- A. Close the snap flaps at the top of the **RIGHT PANEL (23)**, around the top frame. Connect the snaps on the windshield to the vinyl. Fasten the velcro strips on the front panel vinyl and right panel together.

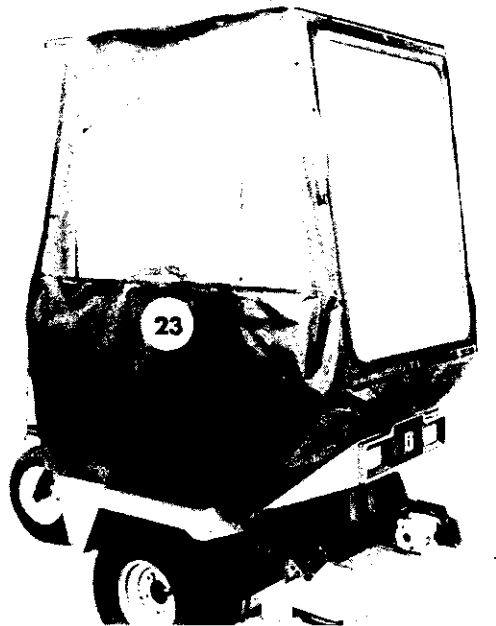

FIGURE 10

STEP 11; SEE FIGURE 11:

Remove the rear deck lid on gasoline models or open the rear cover on diesel models. Close the snap flaps on the upper corners of the **REAR CURTAIN (22)** around the rear of the top frame.

- B. Close the flaps on the left side around the left post. Connect the velcro strip on the right side to the velcro strip on the right panel.
- C. The velcro slit on the right side may be opened to install the exhaust pipe on the right side of the cab for diesel models.
- D. Replace the deck lid or close the cover so that the bottom flap of the rear curtain is held in place.

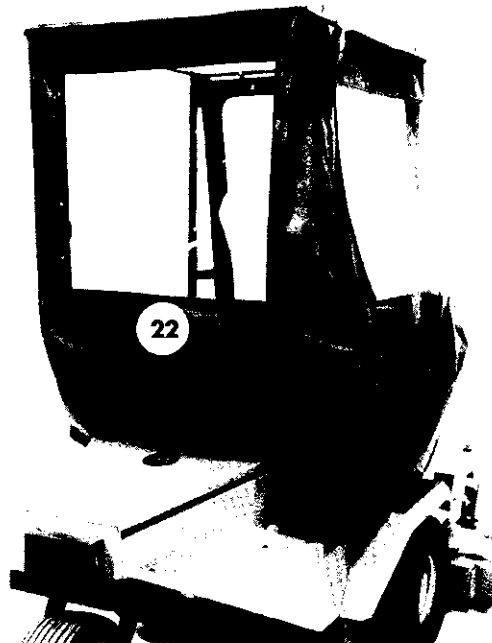

FIGURE 11

STEP 12; SEE FIGURE 12:

- A. Insert the rod at the bottom of the DOOR (24) into the door hinge at REFERENCE E. Slip a door hinge over the rod at the top of the door and secure it to the front post with a bolt and nut at REFERENCE F.
- B. Swing the door into the latch. If it does not line up, loosen the bolt that holds the bottom of the post in place. Move the bottom of the post forward or backward to raise or lower the door. Tighten the bolt.

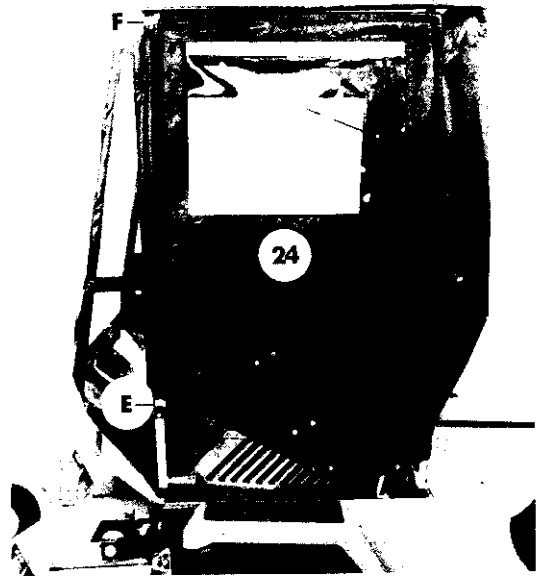

FIGURE 12

STEP 13; SEE FIGURE 13:

- A. Insert two $\frac{1}{4}$ " x $\frac{5}{8}$ " bolts through the holes in the bottom of the door frame with the heads against the vinyl.
- B. Place the DOOR BOTTOM (25) over the bolts add nuts and tighten. Close the snap flaps around the rod.

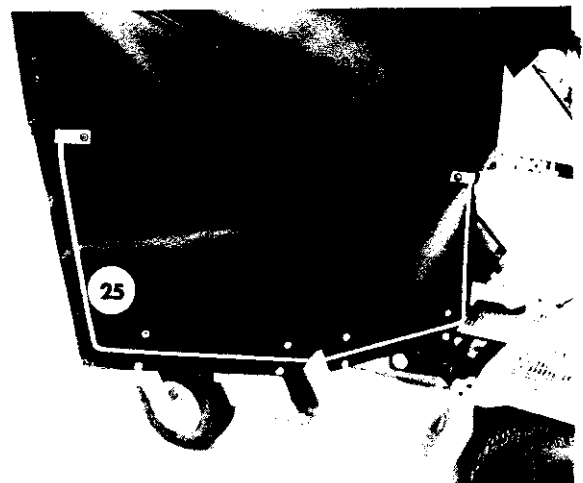

FIGURE 13

INDEX

STEP 14; SEE FIGURE 14:

- A. Place the rod sewn-into the rear curtain over the top frame. Place the PLASTIC TOP (26) onto the top frame so that the rod is held in place.

NOTE: At this time install the exhaust kit on the right side for diesel models, and left side for gasoline models. Use the $\frac{1}{4}$ " x 1" bolt to attach the top strap of the exhaust pipe to the cab top.

- B. Place a $\frac{1}{4}$ " flat washer over each of 3 bolts. Insert the bolts inwards in the remaining holes. Add nuts and tighten.

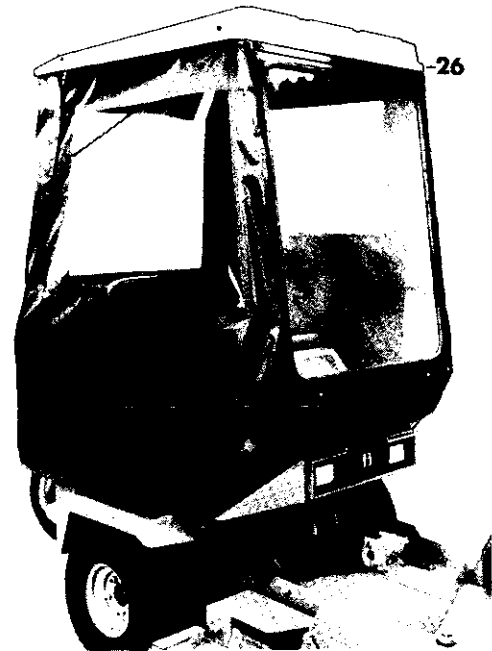

FIGURE 14