



**Ingersoll**

**FRONT CUT TRACTORS  
MODEL 5118D  
Parts Catalog 8-58040**

[HOME](#)

[TRACTORS](#)

[ATTACHMENTS](#)

[INDEX](#)

[PAINT](#)

[ENGINES](#)

[GENERAL INFO](#)

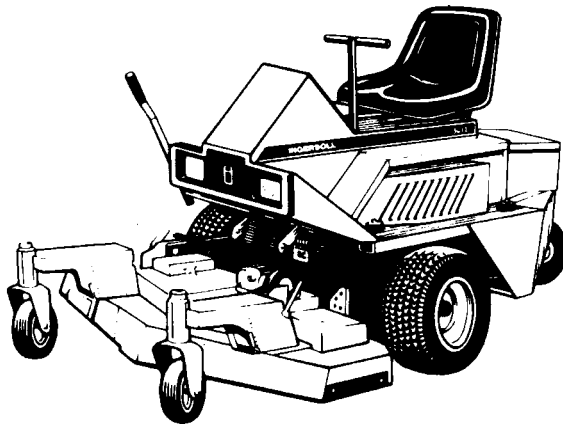

**INDEX**

There is an index at the front of this catalog. The front index is an alphabetical index of the major groups or assemblies.

**ILLUSTRATION**

Each illustration in this catalog shows a group of parts or components. These parts and components are aligned approximately as the parts and components on your machine. Each part and component in an illustration has a reference number. These reference numbers are in a list on the page opposite of the illustration. Next to the reference number is the part number, description and required quantity of the part shown in the illustration.

UAR - "Use as required" indicates that the part quantity is variable.

NSS - "Not sold separately" indicates that the part is only available as component of an assembly or the part must be purchased locally. If the part is an assembly component, the description will be indented under the assembly description in the parts list.

O/L - "Obtain locally"

- "Footnotes" are added to a part number when more information is needed for identification. They only relate to the part numbers indicated. All orders must include the following information:

1. Correct part number.

**PARTS ORDERS**

2. Complete description of part or component.
3. Total quantity of each part or component.
4. Product model number.
5. All necessary product identification numbers.
6. Method for sending the parts.
7. Complete and correct address.

**CATALOG REVISIONS**

As the product changes, new pages will be available for your catalog. A notice will be issued.

**IMPORTANT:** Put all revisions into the catalog as soon as possible.

**RIGHT HAND AND LEFT HAND IDENTIFICATION**

The words right hand (RH) and left hand (LH) as used in this catalog indicate the direction while you are in the operator's seat in the normal operating position.

**INDENTED DESCRIPTIONS**

An assembly can have many components. The components of an assembly are indicated by an indented description. The quantity for an indented part is the total needed for that complete assembly. See the example.

REF.	PART NO.	DESCRIPTION	REQ'D
	C 55159	CYLINDER ASSY - rear steering .....	1
28	C 56208	SOCKET ASSY - rear cylinder .....	1
29	C 55956	PLUG - adjusting, socket assy .....	1
30	C 55957	SEAT- socket, ball.....	2
31	C 56210	SPRING-socket .....	1
32	C 56209	SEAT - socket spring .....	1
33	G 45175	CLAMP ASSY - socket assy .....	1
	16- 836	BOLT-1/2"x2-1/4" N.F. hex.....	1
34	132- 104	PIN-cotter, 3/16"x3" .....	1
35	C 55889	STUD - ball, socket & cylinder .....	2
36	13- 410	BOLT-1/4"x5/8"N.C.,hex .....	4
37	92- 4	LOCK WASHER - 1/4"SAE .....	4

**ENGINE IDENTIFICATION**

**TRACTOR MODEL**

5118D

**ENGINE MODEL**

INGERSOLL NO. C42982  
PERKINS NO.  
TYPE – 103.07  
MODEL – KL70264

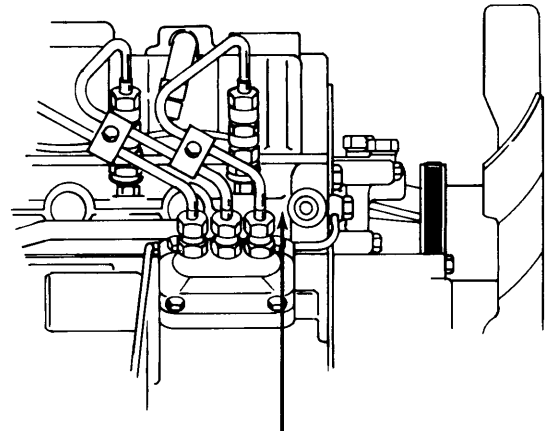

**ENGINE MODEL, SERIAL, AND SPECIFICATION NUMBERS ARE LOCATED BY FUEL INJECTION PUMP**

# ALPHABETICAL INDEX

## ENGINE

Cylinder Block ..... 23  
Flywheel, Crankshaft, Pistons and Rings ..... 25  
Cylinder Head ..... 27  
Rocker Shaft ..... 27  
Timing Gear and Camshaft..... 29  
Camshaft Case and Throttle Linkage ..... 29  
Oil Pump ..... 31  
Throttle Control ..... 31  
Lubrication Components ..... 33  
Glow Plugs ..... 35  
Tachometer ..... 35  
Fuel System ..... 37  
Fuel Pump..... 37  
Fuel Injection System..... 39  
Fuel Injection Pump ..... 41  
Atomizer ..... 41  
Exhaust System ..... 43  
Water Pump, Thermostat, Temperature Sender ..... 49  
Air Cleaner ..... 51  
Engine Mounts ..... 51  
Starter, Plate and Flywheel Shield..... 53  
Alternator and Belt ..... 55  
Alternator Assembly ..... 55  
Gasket Kit..... 57

## TRACTOR

Fuel System (tractor) .....43  
Exhaust System .....43  
Radiator and Shroud.....45  
Radiator Fan Assembly .....47  
Base and Lift Arms.....59  
Body and Attaching Parts .....61  
Seat, Lid and Rear Cover .....63  
Parking Brake .....65  
Drive Wheels.....65  
Single Tail Wheel .....67  
Steering.....69  
Transmission Controls and Cross Shaft .....69  
Drive Idler.....71  
Electric Clutch (PTO) .....71  
Hydraulic System (Drive) .....73  
Hydraulic Lift Assembly .....75  
Electric System .....77  
Decals .....79

## MOWER DECKS

52" Deck, covers, gage wheels, roller.....81  
52" Drive pulleys, blades, spindles, gearbox .....83  
62" Deck, covers, gage wheels, roller.....85  
62" Drive pulleys, blades, spindles, gearbox .....87  
Gear Box – parts detail .....89



**Ingersoll**

## Paint & Oil

**INDEX**

### PAINT

#### **Power Red Gloss**

16-ounce Aerosol Can..... C28484  
Quart ..... C28485

#### **Power White**

16-ounce Aerosol Can..... C28812  
Quart ..... C28845

#### **Power Yellow** (Older 600 Series)

16-ounce Aerosol Can..... C28847  
Quart ..... C28848

#### **Power Tan** (6000 Series)

16-ounce Aerosol Can..... C28853  
Quart ..... C28854

#### **Desert Sunset** (Older 400 Series)

16-ounce Aerosol Can..... C28846  
Quart ..... C28852

#### **Black, Semi Gloss**

16-ounce Aerosol Can..... C28849  
Quart ..... C28850

#### **Black, High Heat**

16-ounce Aerosol Can..... C28851

#### **Silver**

16-ounce Aerosol Can..... C30870

#### **M & W Plum**

16-ounce Aerosol Can..... 10-5688

#### **Grazer Grey**

16-ounce Aerosol Can..... C38444  
Quart ..... C38982

#### **Odyssey Charcoal Grey**

16-ounce Aerosol Can..... C47171

### HYDRAULIC OIL

**20W40**, Use 32 Degrees and above.  
12-Quart Case..... C32778

**5W20**, Use Below 32 Degrees.  
12-Quart Case..... C32777

INDEX

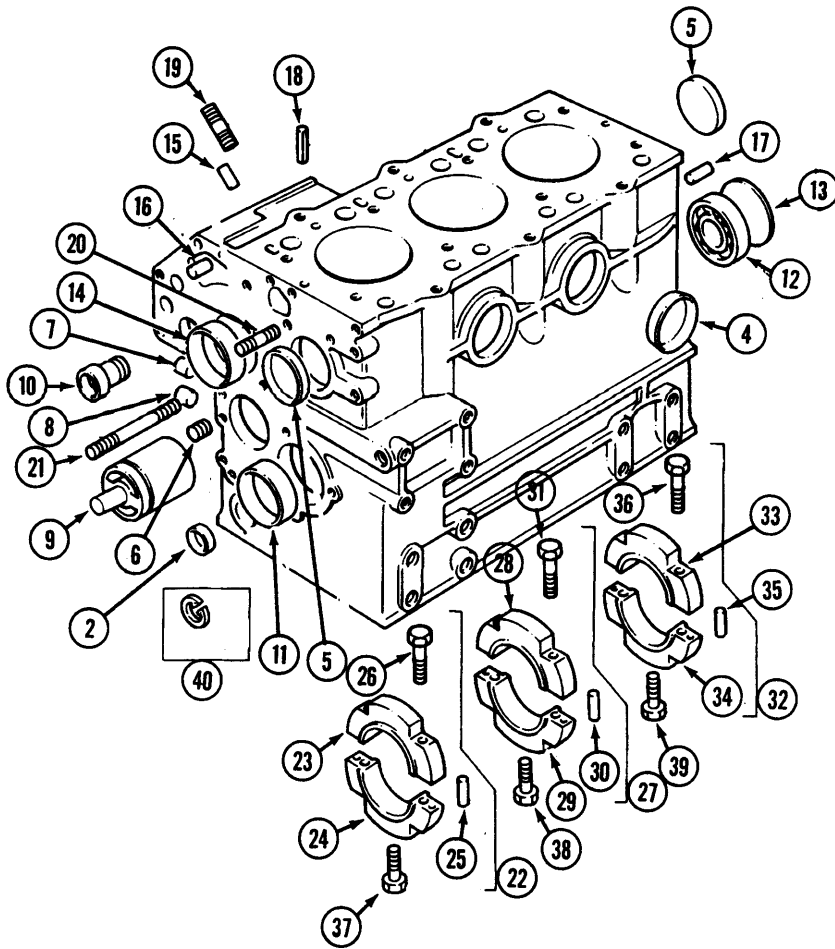
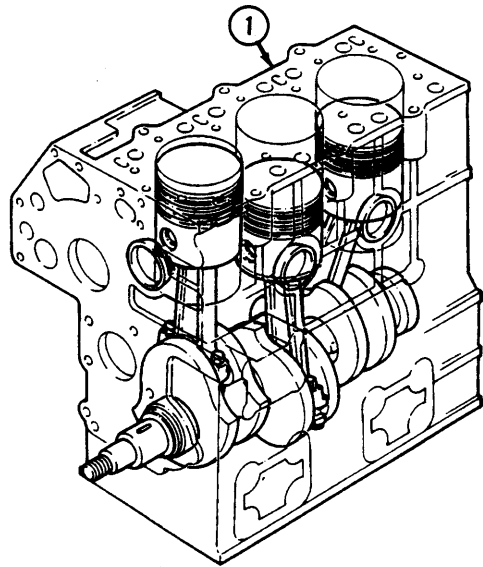

**INDEX**

**CYLINDER BLOCK**  
**NOTE: FOR COMPLETE ENGINE ORDER C42982**

REF.	PART NO.	DESCRIPTION	REQ'D
1	P110006670	BLOCK - cylinder, short .....	1
2	P064200015	PLUG.....	1
4	P064200040	PLUG.....	2
5	P064200040	PLUG.....	2
6	P198466050	PLUG.....	3
7	P198466010	PLUG.....	4
8	P198466070	PLUG.....	2
9	P165296160	SHAFT.....	1
10	P198517090	BUSHING .....	1
11	P198517300	BUSHING - standard.....	1
11	P198517304	BUSHING - 0.25 mm undersize.....	UAR
11	P198517307	BUSHING - 0.50 mm undersize.....	UAR
12	P040106203	BEARING - ball .....	1
13	P064100045	PLUG.....	1
14	P042303015	BUSHING .....	1
15	P030500512	DOWEL .....	2
16	P030500616	DOWEL .....	2
17	P030500820	DOWEL .....	2
18	P030309005	PIN .....	2
19	P012100620	STUD.....	2
20	P012100635	STUD.....	1
21	P012100660	STUD.....	1
22	P110156220	HOLDER .....	1
23	NSS	CAP.....	1
24	NSS	CAP.....	1
25	P030500612	DOWEL.....	2
26	P010810840	SCREW .....	2
27	P110156230	HOLDER .....	1
28	NSS	CAP.....	1
29	NSS	CAP.....	1
30	P030500612	DOWEL.....	2
31	P010810840	SCREW .....	2
32	P110156240	HOLDER .....	1
33	NSS	CAP.....	1
34	NSS	CAP.....	1
35	P030500612	DOWEL.....	2
36	P010810840	SCREW .....	2
37	P011310850	SCREW .....	1
38	P011310850	SCREW .....	1
39	P010700845	SCREW .....	2
40	P036509005	CIRCLIP.....	1
41	P064200018	PLUG .....	2

INDEX

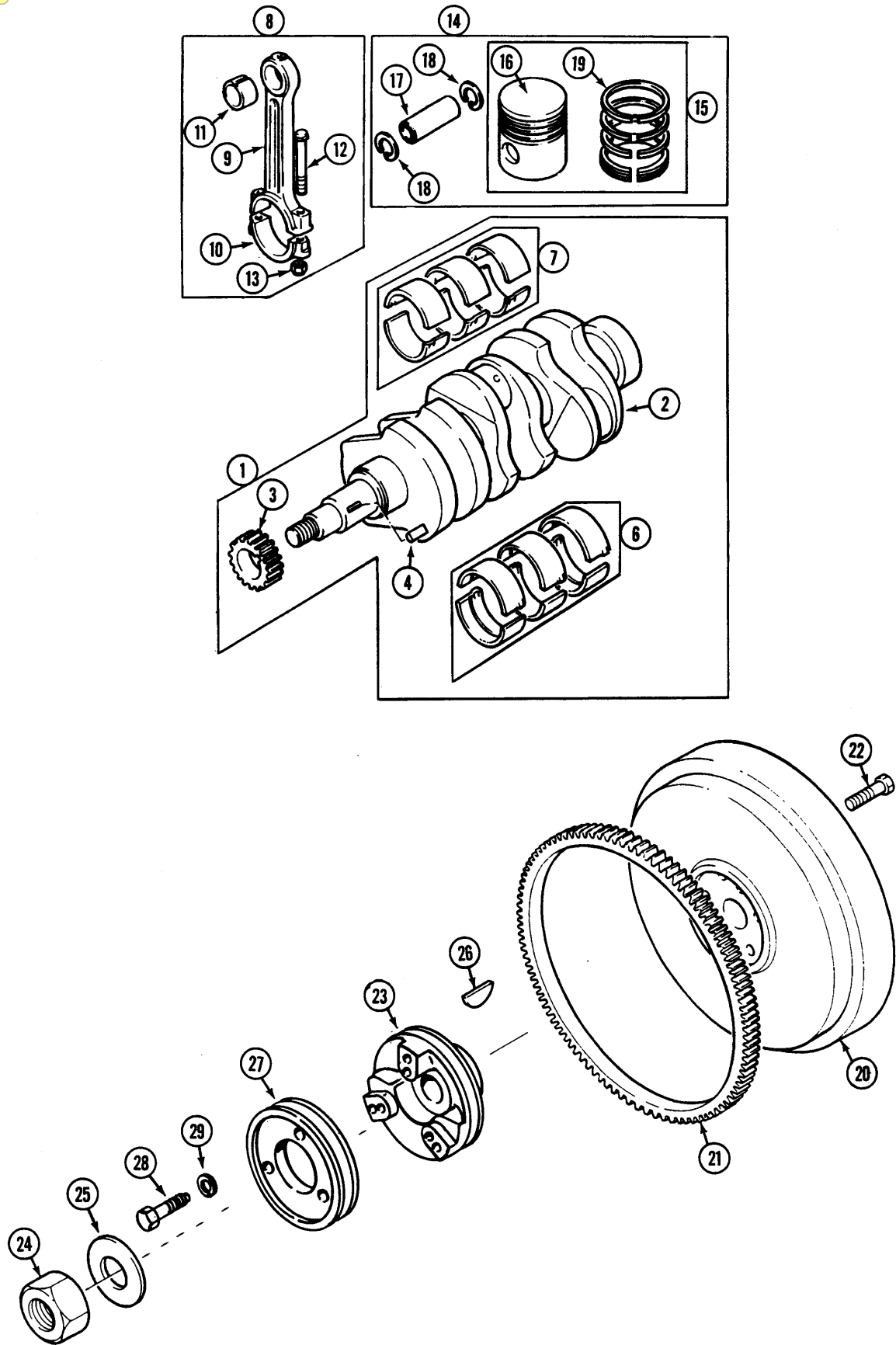



**INDEX**

**FLYWHEEL, CRANKSHAFT, PISTONS AND RINGS**

REF.	PART NO.	DESCRIPTION	REQ'D
1	P115236020	KIT - crankshaft.....	1
2	NSS	CRANKSHAFT.....	1
3	P115276210	GEAR.....	1
4	P030509020	KEY.....	1
6	P198586030	KIT - bearing (standard).....	1
6	P198586034	KIT - bearing (0.25mm undersize).....	UAR
6	P198586037	KIT - bearing (0.50mm undersize).....	UAR
7	P198586060	KIT - bearing (standard).....	1
7	P198586064	KIT - bearing (0.2 5mm undersize).....	UAR
7	P198586067	KIT - bearing (0.50mm undersize).....	UAR
8	P115026240	ROD - connecting.....	3
9	NSS	ROD.....	1
10	NSS	CAP.....	1
11	P198517325	BUSHING.....	1
12	P115176130	SCREW.....	2
13	P020109103	NUT.....	2
14	P115017090	KIT - piston (standard).....	3
14	P115017100	KIT - piston (0.50mm oversize).....	UAR
15	NSS	PISTON ASSEMBLY.....	1
16	NSS	PISTON.....	1
17	P115326260	PIN.....	1
18	P036500019	CIRCLIP.....	2
19	P115107400	KIT - rings (standard).....	1
19	P115107410	KIT - rings (0.50mm oversize).....	1
20	P115357260	FLYWHEEL.....	1
21	P115376150	RING.....	1
22	P010109330	SCREW.....	4
23	C 45367	PULLEY.....	1
24	P020800018	NUT.....	1
25	P026200018	WASHER.....	1
26	P034100508	KEY.....	1
27	C 45369	PULLEY - engine.....	1
28	113-104	BOLT - 5/16" - 18 x 1-1/4.....	3
29	192-20	LOCKWASHER - 5/16".....	3

INDEX

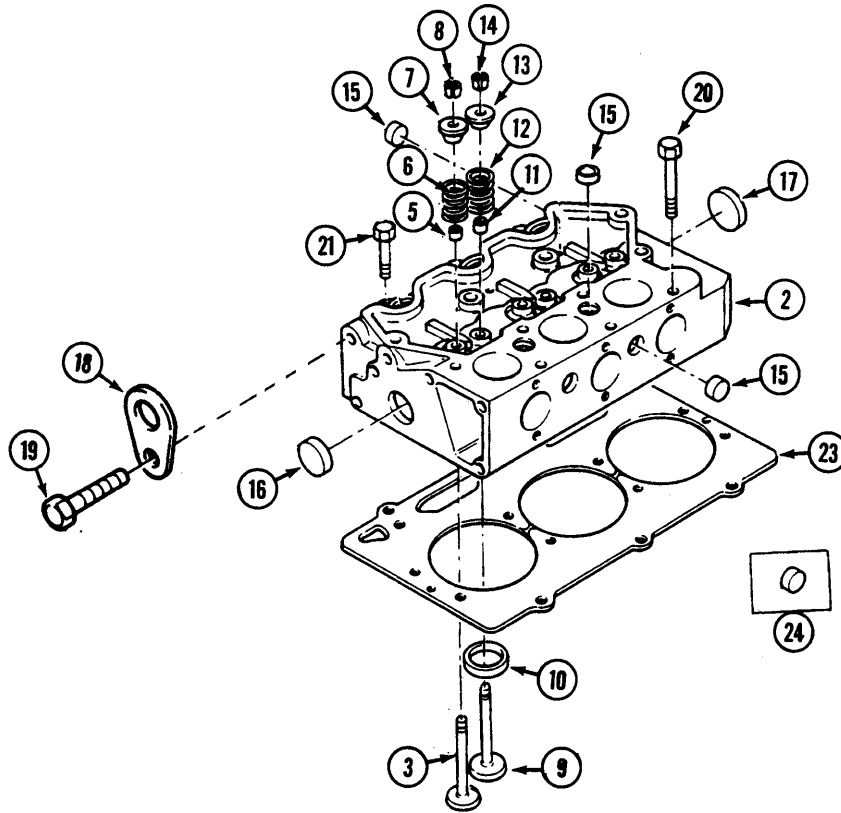

INDEX

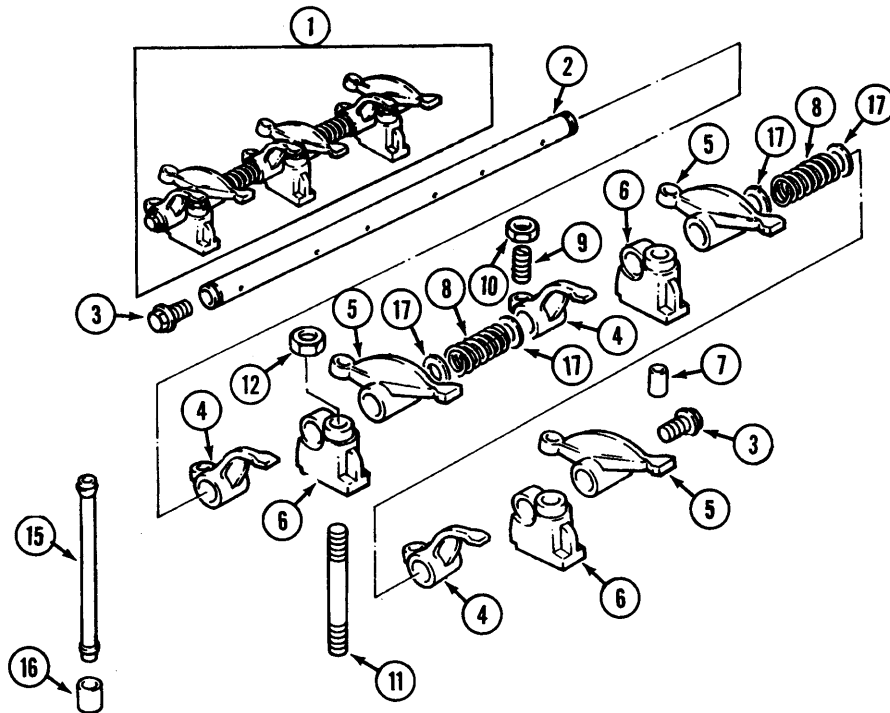

**INDEX****CYLINDER HEAD**

REF.	PART NO.	DESCRIPTION	REQ'D
	P111016911	KIT - cylinder head .....	1
2	P111086030	HEAD - cylinder (includes ref. 15, 16, 17 and 24) .....	1
3	P120166280	VALVE - inlet .....	3
5	P120406080	SEAL .....	3
6	P198217070	SPRING .....	3
7	P120186100	CAP .....	3
8	P120226080	RETAINERS .....	6
9	P120176290	VALVE - exhaust .....	3
10	P110136290	INSERT .....	3
11	P120406080	SEAL .....	3
12	P198217070	SPRING .....	3
13	P120186100	CAP .....	3
14	P120226080	RETAINERS .....	6
15	P198466070	PLUG .....	4
16	P064200022	PLUG .....	3
17	P064200022	PLUG .....	3
18	P195816200	PLATE - lifting .....	2
19	P011310816	SCREW .....	2
20	P111136340	SCREW .....	11
21	P111136350	SCREW .....	3
23	C43611	GASKET .....	1
23	P111147390	GASKET - (0.5mm oversize) .....	UAR
24	P064200018	PLUG - included in cylinder head kit .....	2

**INDEX****ROCKER SHAFT**

1	P120036330	SHAFT ASSEMBLY - rocker .....	1
2	P120316190	SHAFT .....	1
3	P064609006	PLUG .....	2
4	P120356120	LEVER-L.H .....	3
5	P120356110	LEVER - R.H. ....	3
6	P120346170	BRACKET .....	3
7	P030300325	PIN .....	1
8	P198217080	SPRING .....	2
9	P199486220	SCREW - adjusting .....	6
10	P020109076	NUT .....	6
11	P012109177	STUD .....	3
12	P023100008	NUT .....	3
15	P120456240	ROD .....	6
16	P120116100	TAPPET .....	6
17	P199280280	WASHER - included with shaft assembly .....	4

INDEX

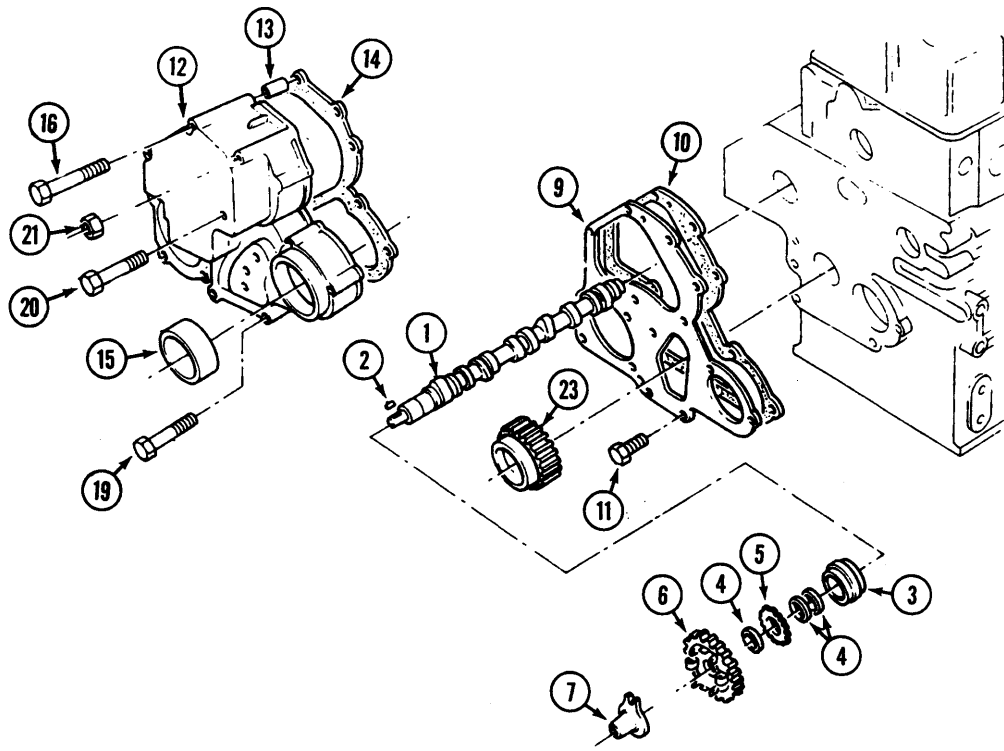

INDEX

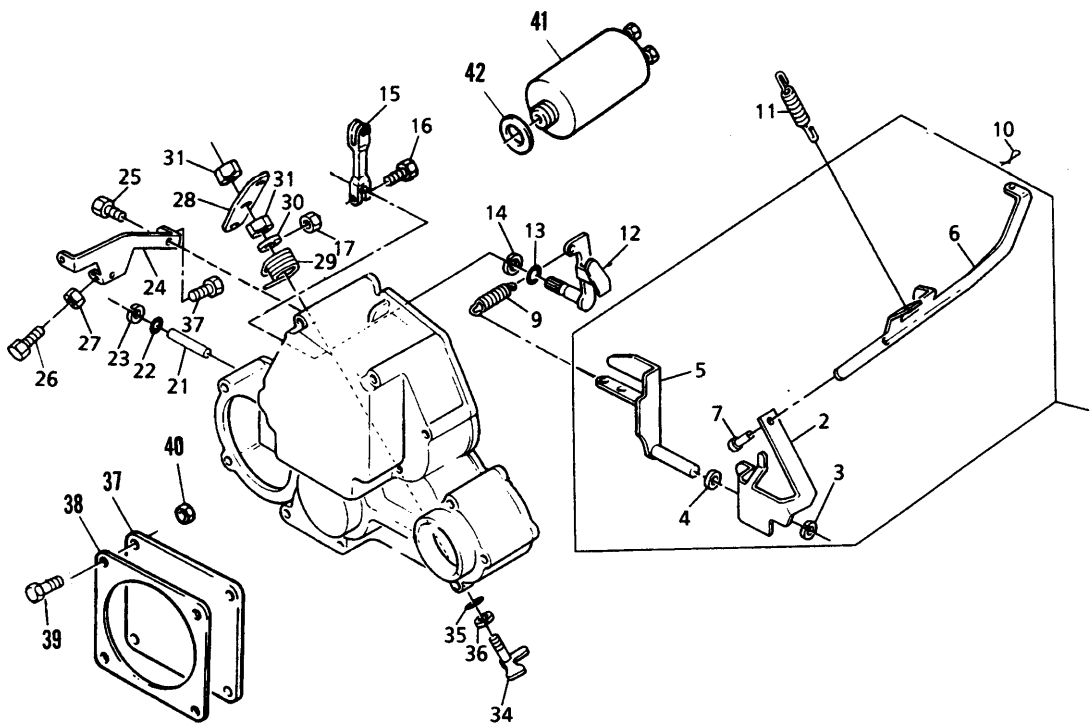

**INDEX**

**TIMING GEAR AND CAMSHAFT**

REF.	PART NO.	DESCRIPTION	REQ'D
1	P120026120	CAMSHAFT .....	1
2	P034100508	KEY .....	1
3	P040109059	BEARING .....	1
4	P199216230	SPACER .....	3
5	P120736081	GEAR .....	1
6	P120016030	GEAR .....	1
7	P125256120	TAPPET .....	1
9	P165166260	PLATE .....	1
10	C43612	GASKET .....	1
11	P011300612	BOLT .....	3
12	P165106131	CASE .....	1
13	P030300414	PIN.....	12
14	C43613	GASKET .....	1
15	P198636090	SEAL .....	1
16	P011300680	SCREW .....	2
19	P011300640	SCREW .....	4
20	P011300660	SCREW .....	2
21	P023100006	NUT .....	1
23	NSS	GEAR - <a href="#">see oil pump page 31</a> .....	1

**INDEX**

**CAMSHAFT CASE AND THROTTLE LINKAGE**

1	P125046140	LEVER ASSEMBLY.....	1
2	NSS	LEVER .....	1
3	P036800008	CIRCLIP .....	1
4	P026200010	WASHER .....	1
5	P125406071	LEVER .....	1
6	NSS	LINK.....	1
7	NSS	PIN.....	1
9	P198217110	SPRING .....	1
10	P031100004	PIN.....	1
11	P198216731	SPRING.....	1
12	P125156170	ARM.....	1
13	P052100070	"O" RING .....	1
14	P036800008	CIRCLIP .....	1
15	P125416020	LEVER .....	1
16	P010110630	SCREW .....	1
17	P023100006	NUT .....	1
21	P125116130	SHAFT.....	1
22	P052100030	"O" RING .....	1
23	P036800005	CIRCLIP .....	1
24	P125976120	STAY .....	1
25	P011300616	SCREW .....	2
26	P010109264	SCREW .....	2
27	P023100006	NUT .....	2
28	P125176080	LEVER.....	1
29	P198216760	SPRING.....	1
30	P026200008	WASHER.....	1
31	P020300008	NUT .....	2
34	P125156180	ARM.....	1
35	P052100050	"O" RING .....	1
36	P036800006	CIRCLIP.....	1
37	P165206360	PLATE .....	1
38	P165996420	GASKET .....	1
39	P010110850	SCREW .....	4
40	P023100008	NUT .....	4
41	P185206082	SOLENOID - fuel shut off .....	1
42	P025100016	WASHER.....	1

INDEX

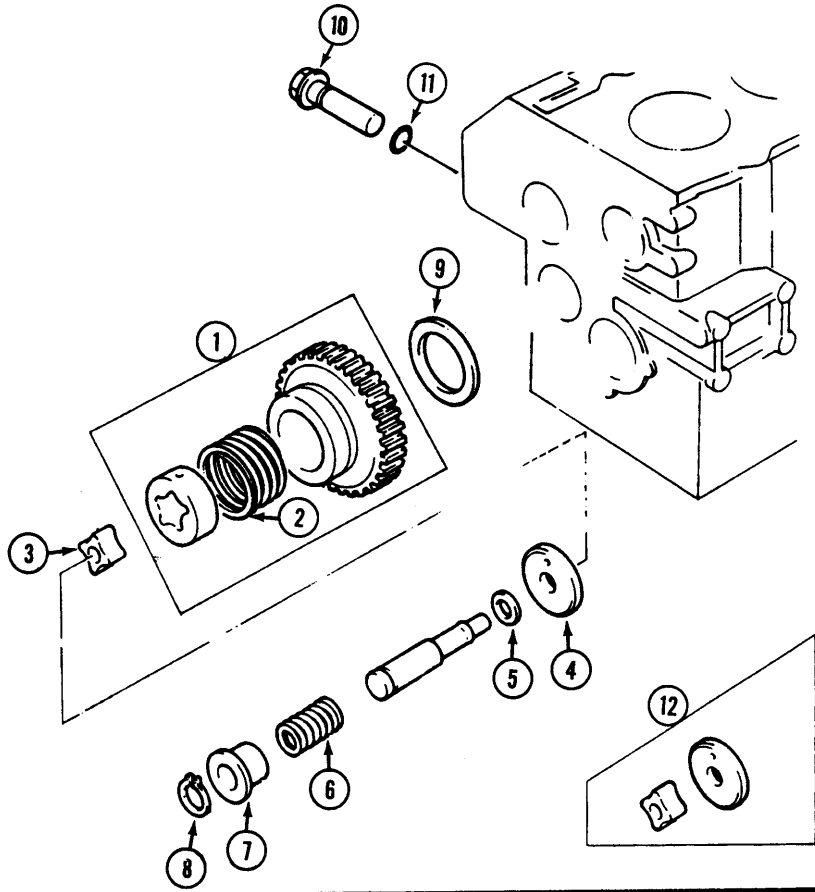

INDEX

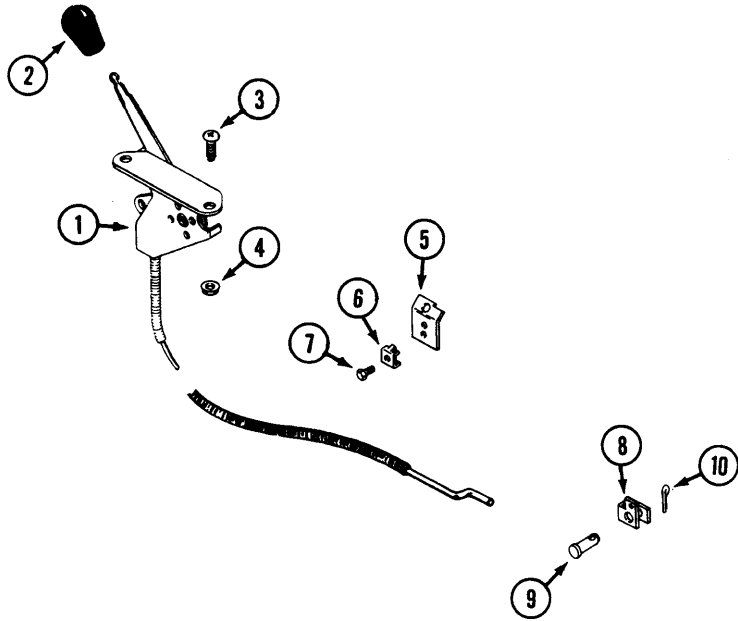

**INDEX****OIL PUMP**

REF.	PART NO.	DESCRIPTION	REQ'D
1	P165026110	GEAR ASSEMBLY .....	1
2	P198216821	SPRING .....	1
3	P140166130	ROTOR .....	1
4	P140116140	COVER.....	1
5	P199286150	SHIM - 0.10mm .....	UAR
5	P199286160	SHIM - 0.15mm .....	UAR
5	P199286170	SHIM - 0.20mm .....	UAR
5	P199286180	SHIM - 0.50mm .....	UAR
6	P198216720	SPRING.....	1
7	P199236540	COLLAR.....	1
8	P036800010	CIRCLIP .....	1
9	P199266180	WASHER.....	1
10	P140036120	VALVE.....	1
11	P052100150	"O" RING .....	1
12	P140186010	KIT - repair .....	1

**INDEX****THROTTLE CONTROL**

1	C43177	THROTTLE .....	1
2	C35291	KNOB - throttle.....	1
3	182-559	SCREW - #10 - 24 x 3/4" .....	2
4	C34117	NUT - #10 - 24 flange lock .....	2
5	C45339	BRACKET - throttle .....	1
6	C34273	CLAMP - casing .....	1
7	182-559	SCREW - #10-24 x 3/4" .....	1
8	C43059	CLEVIS - extension.....	1
9	C45478	PIN - clevis 5/16" x 7/8" .....	1
10	132-320	PIN - cotter 3/32" x 3/4" .....	1

INDEX

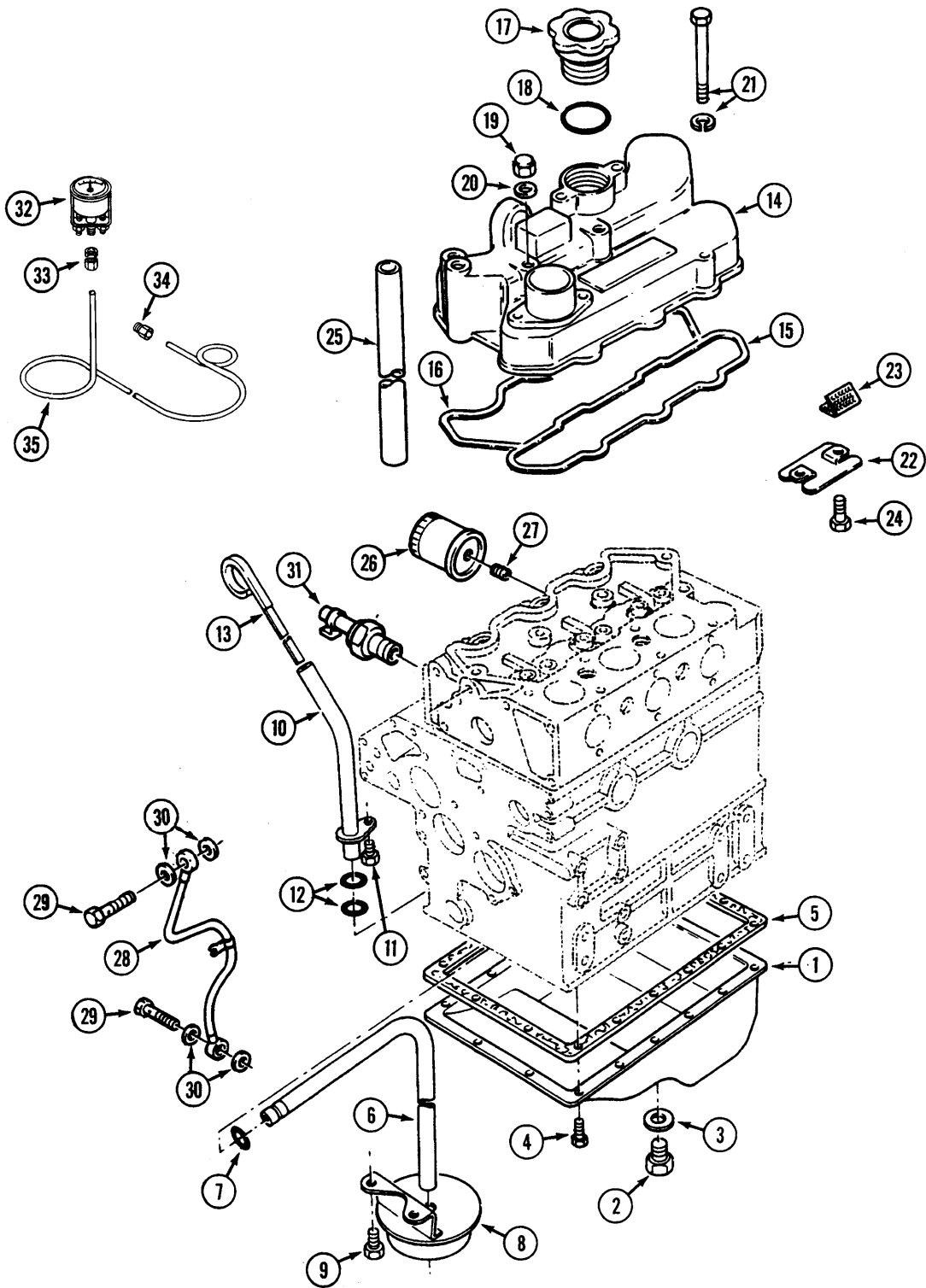



**INDEX**

**LUBRICATION COMPONENTS**

REF.	PART NO.	DESCRIPTION	REQ'D
1	P110706860	SUMP .....	1
2	C43607	PLUG.....	1
3	C43608	WASHER.....	1
4	P010109235	SCREW .....	18
5	C43614	GASKET .....	1
6	P140986590	PIPE .....	1
7	P052109076	"O" RING .....	1
8	P140406310	STRAINER .....	1
9	P011300612	BOLT .....	2
10	C43997	TUBE .....	1
11	P011300612	BOLT .....	1
12	C43999	"O" RING .....	1
13	C43207	DIPSTICK.....	1
14	P111026371	COVER.....	1
15	C43615	GASKET .....	1
16	C43616	GASKET .....	1
17	C43605	CAP .....	1
18	C43606	"O" RING .....	1
19	P024500008	NUT .....	3
20	P198996060	WASHER.....	3
21	P011300650	SCREW .....	2
22	P110666110	PLATE .....	1
23	P110666120	GAUZE .....	1
24	P011300612	BOLT .....	2
25	P068122560	HOSE .....	1
26	C43443	FILTER - oil .....	1
27	P140546020	CONNECTOR .....	1
28	P140606680	PIPE .....	1
29	P198486780	BOLT .....	1
30	P198996060	WASHER.....	4
31	C43601	SWITCH - oil pressure .....	1
32	C38122	GAGE - pressure, oil .....	1
33	C45606	FITTING - 1/8" tube .....	1
34	222-681	FITTING - 1/8" x 1/8" .....	1
35	C45544	TUBE - 1/8" x 58" copper .....	1

**INDEX**

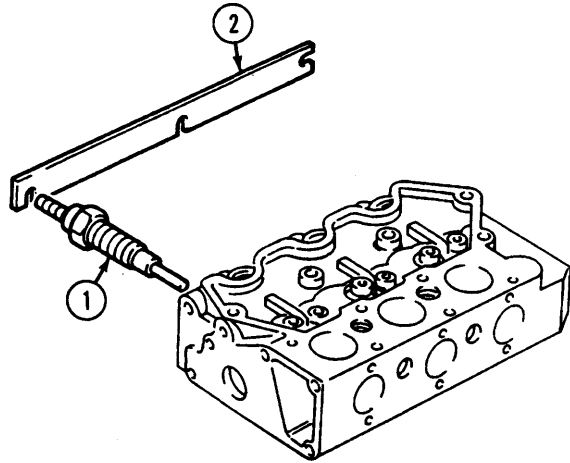

---

**INDEX**

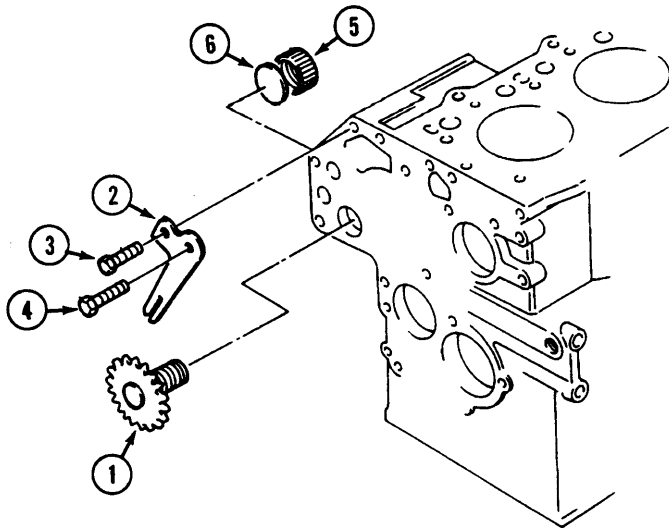

**INDEX**

**GLOW PLUGS**

REF.	PART NO.	DESCRIPTION	REQ'D
1	C43603	HEATER - glow plugs .....	3
2	P185376170	BAR .....	1

**TACHOMETER**

1	P120076070	SHAFT.....	1
2	P199566651	PLATE .....	1
3	P011310612	SCREW .....	1
4	P010700610	SCREW .....	1
5	P199376230	CAP .....	1
6	P120996060	SEAL .....	1

INDEX

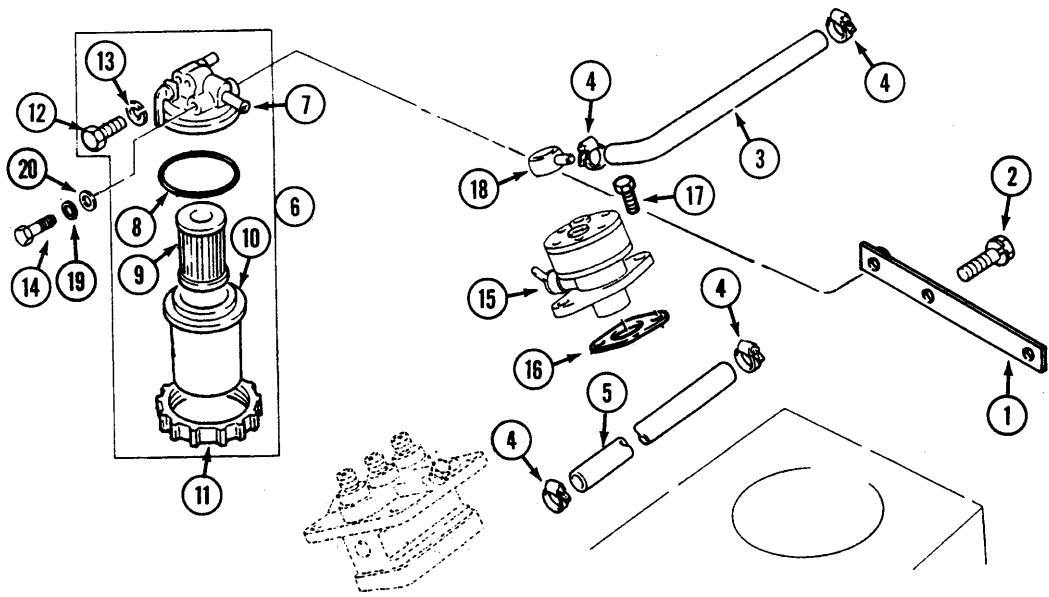

INDEX

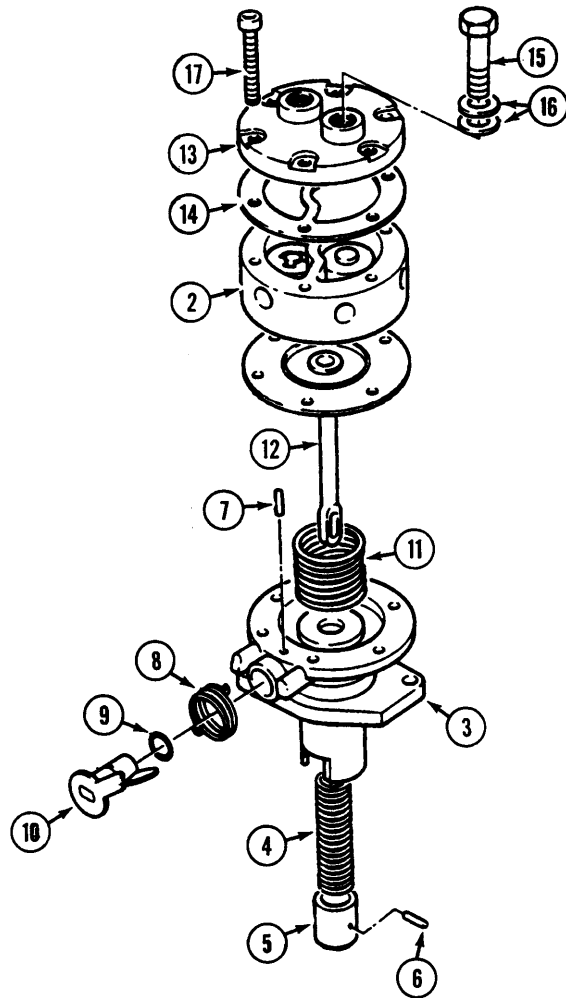

**INDEX****FUEL SYSTEM (ENGINE)**

REF.	PART NO.	DESCRIPTION	REQ'D
1	C45468	BRACKET - fuel filter mounting .....	1
2	P011310816	SCREW .....	2
3	C45470	HOSE - fuel (pump to filter) 5.5" .....	1
4	P198346020	CLAMP-hose .....	4
5	C42988	HOSE - filter to injection pump .....	1
6	P130306041	FILTER ASSEMBLY - fuel .....	1
7	NSS	HEAD .....	1
8	C43597	"O" RING .....	1
9	C43444	ELEMENT - fuel filter .....	1
10	P130336031	CONTAINER .....	1
11	P130446090	RING .....	1
12	P130446080	PLUG .....	2
13	P130326120	WASHER .....	2
14	113-111	BOLT - 5/16" - 18 x 2-1/2" .....	1
15	C43604	PUMP - fuel (repairs below) .....	1
16	P130996070	GASKET .....	1
17	P011140616	SCREW .....	2
18	P198486840	CONNECTOR .....	2
19	192-20	LOCKWASHER - 5/16" .....	1
20	195-521	WASHER - 5/16" .....	1

**INDEX****FUEL PUMP**

1	C43604	PUMP - fuel .....	1
2	NSS	BODY - upper .....	1
3	P130516080	BODY - lower .....	1
4	P130516081	SPRING .....	1
5	P130516082	PLUNGER .....	1
6	P130516085	PIN .....	1
7	P130516088	PIN .....	1
8	P130516083	SPRING .....	1
9	P131226180	"O" RING .....	1
10	P130516086	LEVER .....	1
11	P130516087	SPRING .....	1
12	P130516084	DIAPHRAGM .....	1
13	P130516090	CAP .....	1
14	P130516089	GASKET .....	1
15	P130516092	BOLT .....	2
16	P130516069	WASHER .....	4
17	P130516091	SCREW .....	6

INDEX

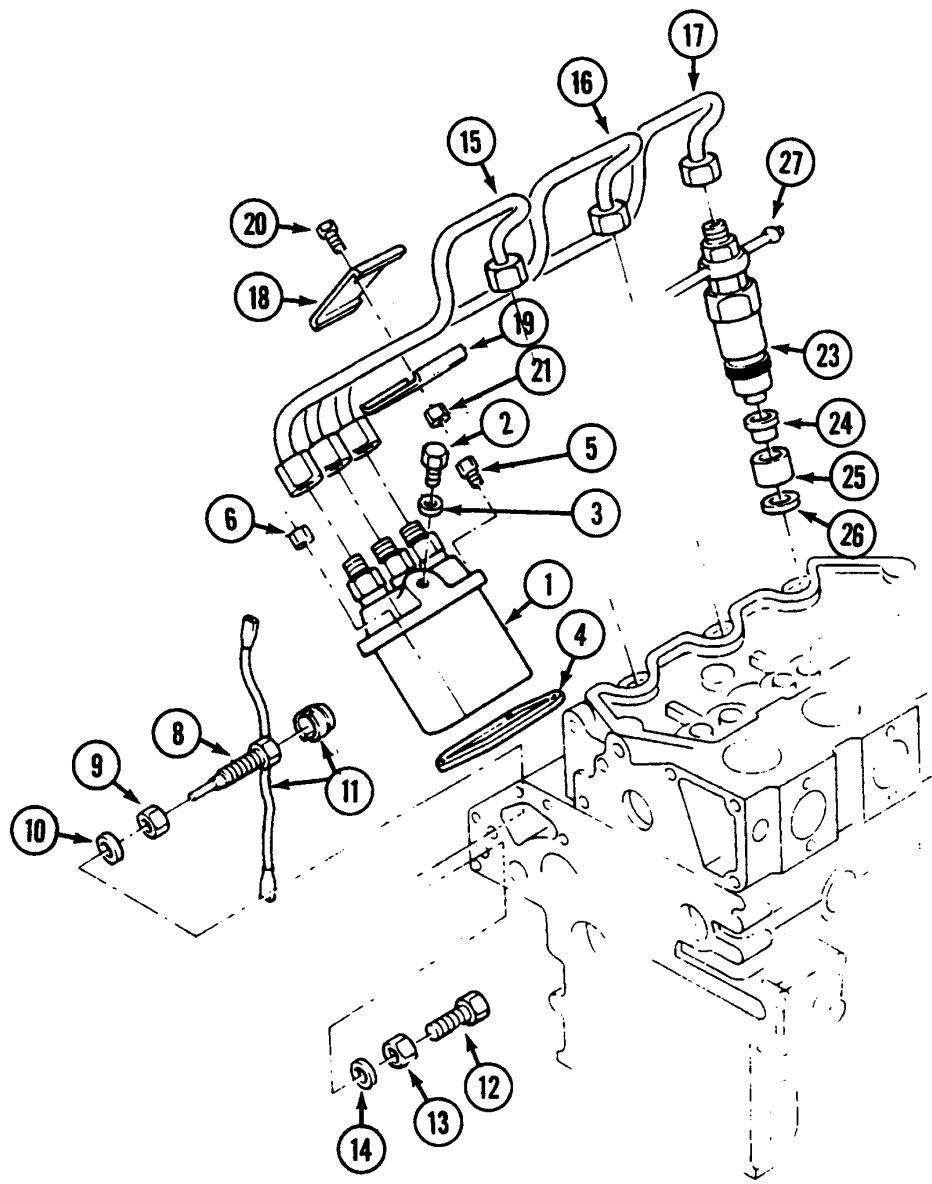

**INDEX**

**FUEL INJECTION SYSTEM**

REF.	PART NO.	DESCRIPTION	REQ'D
1	P131017390	PUMP - injection (repairs page 23) .....	1
2	P131236280	SCREW .....	1
3	P025100006	WASHER.....	1
4	P131437310	SHIM - 0.2mm .....	UAR
4	P131437320	SHIM - 0.3mm .....	UAR
4	P131437330	SHIM - 0.4mm .....	UAR
4	P131437340	SHIM - 0.5mm .....	UAR
5	P011300620	SCREW .....	2
6	P023100006	NUT .....	6
8	P131046160	SCREW .....	1
9	P023109002	NUT .....	1
10	P025100010	WASHER.....	1
11	P198236030	WIRE .....	1
12	P010109270	SCREW .....	1
13	P023109002	NUT .....	1
14	P025100010	WASHER.....	1
15	P131507010	PIPE - injection (No. 1 cylinder) .....	1
16	P131507020	PIPE - injection (No. 2 cylinder) .....	1
17	P131507030	PIPE - injection (No. 3 cylinder) .....	1
18	P199106020	DAMPER .....	2
19	P199106020	DAMPER .....	2
20	P010100625	SCREW .....	2
21	P023100006	NUT .....	2
23	P131406340	ATOMIZER - fuel (repairs page 23).....	3
24	P131426200	GASKET .....	3
25	P111316280	INSERT .....	3
26	P198996090	SEAL .....	3
27	P131606260	PIPE .....	1

INDEX

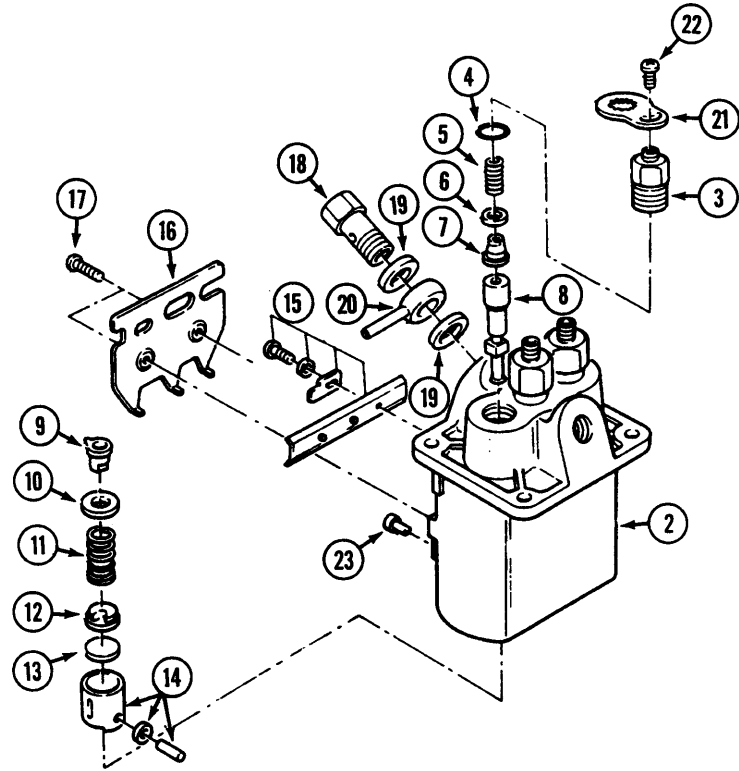

INDEX

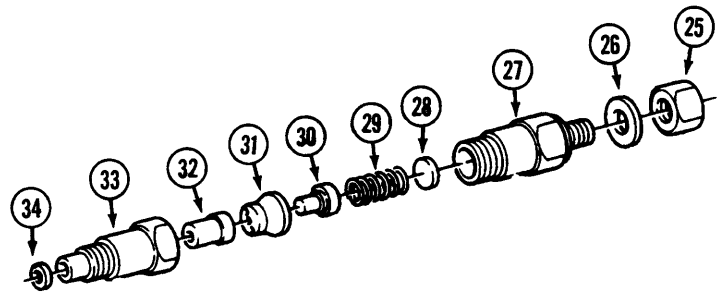



**INDEX**

**FUEL INJECTION PUMP**

REF.	PART NO.	DESCRIPTION	REQ'D
	P131017390	PUMP - fuel injection.....	1
2	P131296665	HOUSING.....	1
3	P131196130	HOLDER.....	3
4	P131226170	"O" RING.....	3
5	P131176430	SPRING.....	3
6	P131186050	GASKET.....	3
7	P131156160	VALVE.....	3
8	P131116410	ELEMENT.....	3
9	P131296951	SLEEVE.....	3
10	P131296620	SEAT.....	3
11	P131176440	SPRING.....	3
12	P131296621	SEAT.....	3
13	P131296622	PLATE - shim 1.85mm.....	UAR
13	P131296623	PLATE - shim 1.90mm.....	UAR
13	P131296624	PLATE - shim 1.95mm.....	UAR
13	P131296625	PLATE - shim 2.00mm.....	UAR
13	P131296626	PLATE - shim 2.05mm.....	UAR
13	P131296627	PLATE - shim 2.10mm.....	UAR
13	P131296628	PLATE - shim 2.15mm.....	UAR
13	P131296629	PLATE - shim 2.20mm.....	UAR
13	P131296630	PLATE - shim 2.25mm.....	UAR
13	P131296631	PLATE - shim 2.30mm.....	UAR
13	P131296632	PLATE - shim 2.35mm.....	UAR
13	P131296633	PLATE - shim 2.40mm.....	UAR
13	P131296634	PLATE - shim 2.45mm.....	UAR
13	P131296635	PLATE - shim 2.50mm.....	UAR
14	P131256120	TAPPET.....	3
15	P131296636	RACK.....	1
16	P131296650	BRACKET.....	1
17	P131136320	SCREW.....	2
18	P131236190	BOLT.....	1
19	P131426180	WASHER.....	2
20	P131246130	NIPPLE.....	1
21	P131296662	PLATE.....	3
22	P131136330	SCREW.....	3
23	P131296651	PIN.....	3

**INDEX**

**ATOMIZER**

	P131406340	ATOMIZER.....	3
25	P131446069	NUT.....	1
26	P131426210	WASHER.....	1
27	P131446065	BODY.....	1
28	P131437250	SHIM - 0.90mm.....	UAR
28	P131437251	SHIM - 0.925mm.....	UAR
28	P131437252	SHIM - 0.95mm.....	UAR
28	P131437253	SHIM - 0.975mm.....	UAR
28	P131437254	SHIM - 1.00mm.....	UAR
28	P131437255	SHIM - 1.025mm.....	UAR
28	P131437256	SHIM - 1.05mm.....	UAR
28	P131437257	SHIM - 1.075mm.....	UAR
28	P131437258	SHIM - 1.10mm.....	UAR
28	P131437259	SHIM - 1.125mm.....	UAR
28	P131437260	SHIM - 1.15mm.....	UAR
28	P131437261	SHIM - 1.175mm.....	UAR
28	P131437262	SHIM - 1.20mm.....	UAR
28	P131437263	SHIM - 1.225mm.....	UAR
28	P131437264	SHIM - 1.250mm.....	UAR
28	P131437265	SHIM - 1.275mm.....	UAR
28	P131437266	SHIM - 1.30mm.....	UAR
28	P131437267	SHIM - 1.325mm.....	UAR
28	P131437268	SHIM - 1.35mm.....	UAR
28	P131437269	SHIM - 1.375mm.....	UAR
28	P131437270	SHIM - 1.40mm.....	UAR
28	P131437271	SHIM - 1.425mm.....	UAR
28	P131437272	SHIM - 1.45mm.....	UAR
29	P131446066	SPRING.....	1
30	P131446070	PIN.....	1
31	P131446068	SPACER.....	1
32	P131416150	NOZZLE.....	1
33	P131446067	NUT.....	1

INDEX

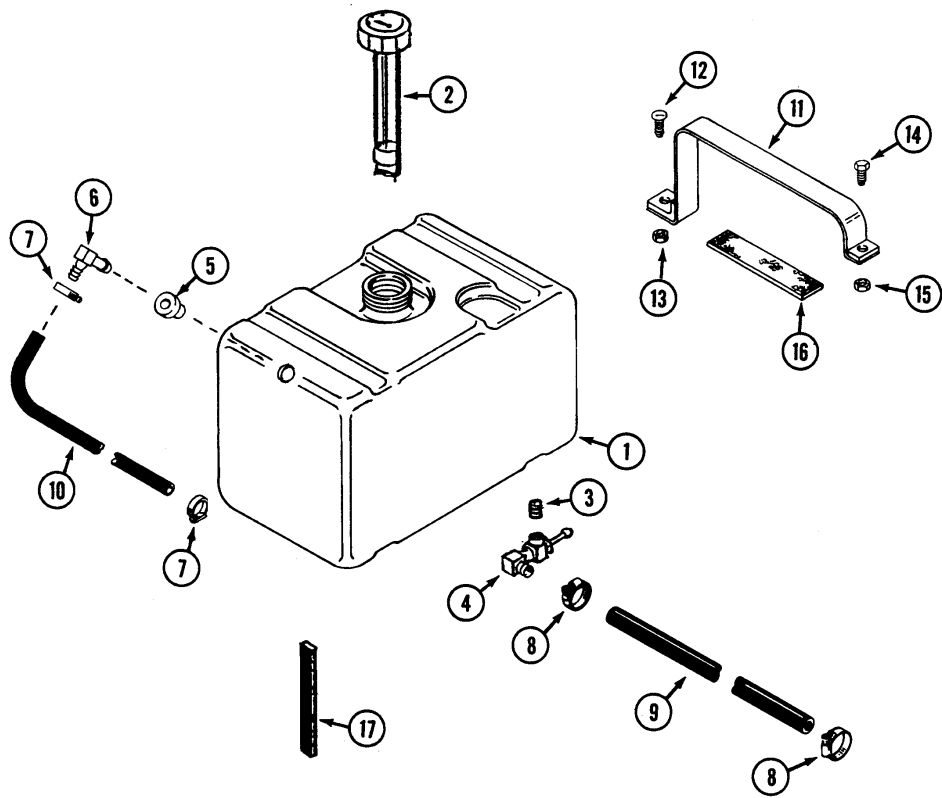

INDEX

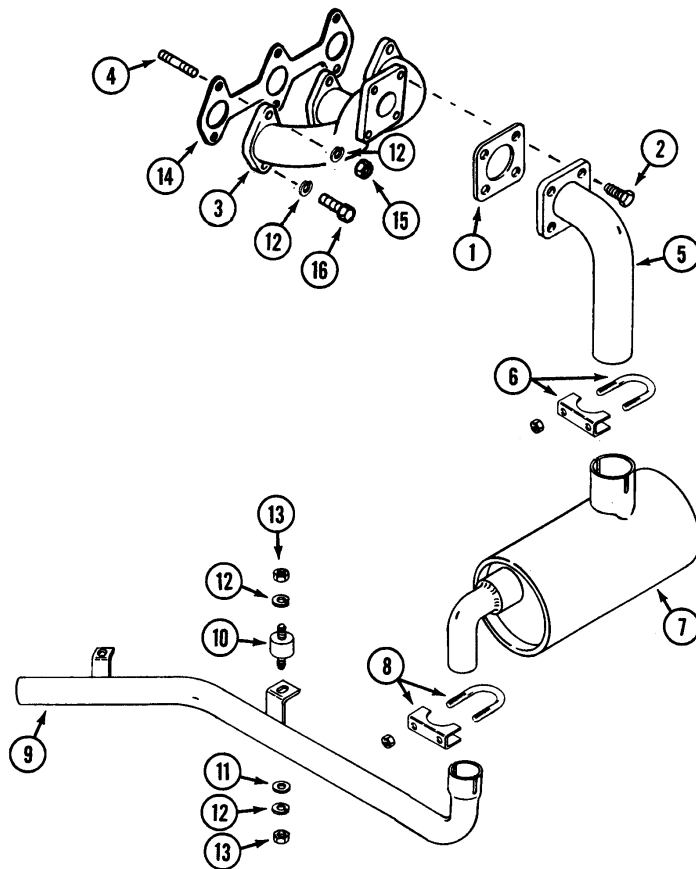

**INDEX****FUEL SYSTEM (TRACTOR)**

REF.	PART NO.	DESCRIPTION	REQ'D
1	C45312	TANK - fuel.....	1
2	C45334	CAP - fuel gauge.....	1
3	221-1101	NIPPLE - pipe 1/8".....	1
4	C37811	FITTING - valve 1/8" x 90°.....	1
5	C43052	GROMMET - tank.....	1
6	C43053	FITTING - return 90°.....	1
7	214-274	CLAMP - hose #4.....	2
8	214-103	CLAMP - hose #8.....	2
9	C43270	HOSE - fuel 1/4" x 45".....	1
10	C43271	HOSE - return 3/16" x 51".....	1
11	C45313	STRAP - fuel tank.....	2
12	113-103	BOLT-5/16"-18x1".....	2
13	131-69	NUT - 5/16" - 18 lock.....	2
14	113-3	BOLT - 1/4" - 20 x 3/4".....	2
15	131-71	NUT - 1/4" -20 lock.....	2
16	C34189	CUSHION.....	4
17	C44584	FOAM - tank cushion.....	1

**INDEX****EXHAUST SYSTEM**

1	C42833	GASKET - exhaust.....	1
2	C42834	BOLT - M8-1.25 x 25.....	4
3	C45769	MANIFOLD - exhaust.....	1
4	C45770	STUD - manifold.....	3
5	C43135	PIPE - engine to muffler.....	1
6	C42055	CLAMP - muffler 1-3/4".....	1
7	C45461	MUFFLER ASSEMBLY.....	1
8	C31417	CLAMP - muffler 1-3/8".....	1
9	C45444	PIPE - exhaust.....	1
10	C43012	MOUNT - rubber.....	1
11	195-518	WASHER - 1/4".....	2
12	192-19	LOCKWASHER - 1/4".....	10
13	129-101	NUT - 1/4" -20.....	4
14	C43988	GASKET - manifold.....	1
15	825-1106	NUT - M6-1.0.....	3
16	814-6025	BOLT - M6-1.0 x 25.....	3

INDEX

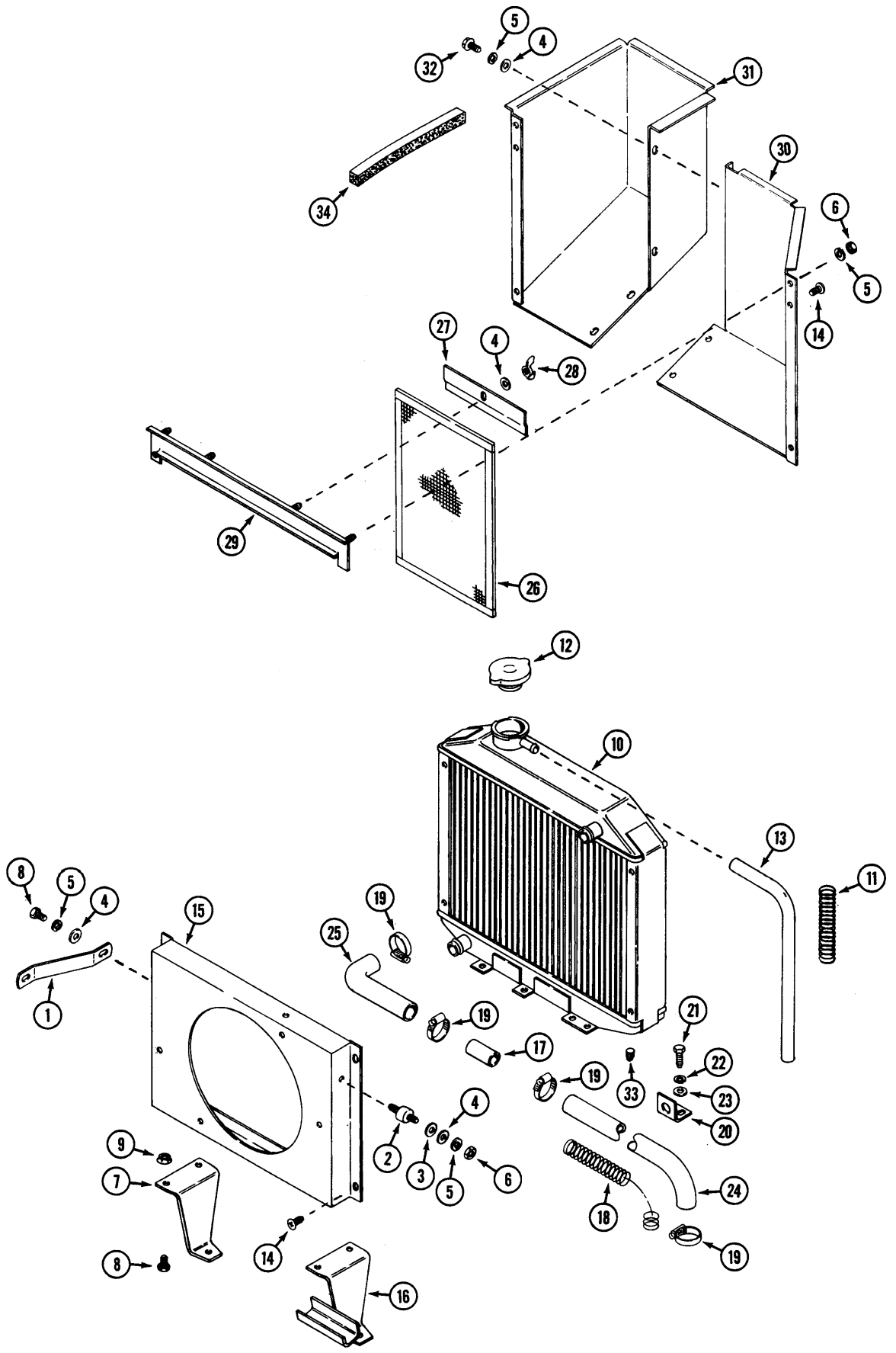

**INDEX****RADIATOR AND SHROUD**

REF.	PART NO.	DESCRIPTION	REQ'D
1	C45310	STRAP - radiator mount.....	1
2	C43012	MOUNT - rubber .....	3
3	C37704	WASHER - .33" x .69" .....	1
4	195-518	WASHER - 1/4" .....	7
5	192-19	LOCKWASHER - 1/4" .....	9
6	129-101	NUT - 1/4".....	5
7	C45206	BRACKET - radiator - support, rear .....	1
8	113-1	BOLT - 1/4" - 20 x 1/2" .....	4
9	131-934	NUT - 1/4" - 20 flange lock .....	4
10	C43211	RADIATOR.....	1
11	C45633	SPRING - hose liner.....	1
12	C43009	CAP - radiator .....	1
13	C43011	HOSE - overflow .....	1
14	C33576	SCREW - 1/4" - 20 x 5/16" .....	5
15	C45308	SHROUD - fan .....	1
16	C45464	BRACKET - radiator support, front .....	1
17	C43367	TUBE - .88" x 2" .....	2
18	C44567	SPRING - hose liner.....	2
19	214-255	CLAMP - hose #16.....	9
19	214-256	CLAMP - hose #20.....	2
20	C45311	BRACKET - hose support, upper .....	1
20	C44604	BRACKET - hose support, lower .....	1
21	814-8016	BOLT - M8 - 1.25 x 16.....	3
22	192-20	LOCKWASHER - 5/16" .....	3
23	195-102	WASHER - .312" x .75" .....	2
24	C43368	HOSE - .88" x 13.5" top engine.....	1
24	C43369	HOSE - .88 x 32" lower engine .....	1
25	C33551	HOSE - 90° .....	2
26	C45447	SCREEN - radiator.....	2
27	C45450	BRACKET - screen mounting .....	2
28	129-409	NUT - wing 1/4" - 20.....	2
29	C45451	RAIL - upper, screen mounting .....	1
30	C45453	DUCT - air, front.....	1
31	C45457	DUCT - air, rear.....	1
32	187-1036	SCREW - 1/4" - 20 x 1/2" flange .....	4
33	C43010	PLUG - drain (included with radiator).....	1
34	C42772	SEAL - air intake 13.2" .....	1

INDEX

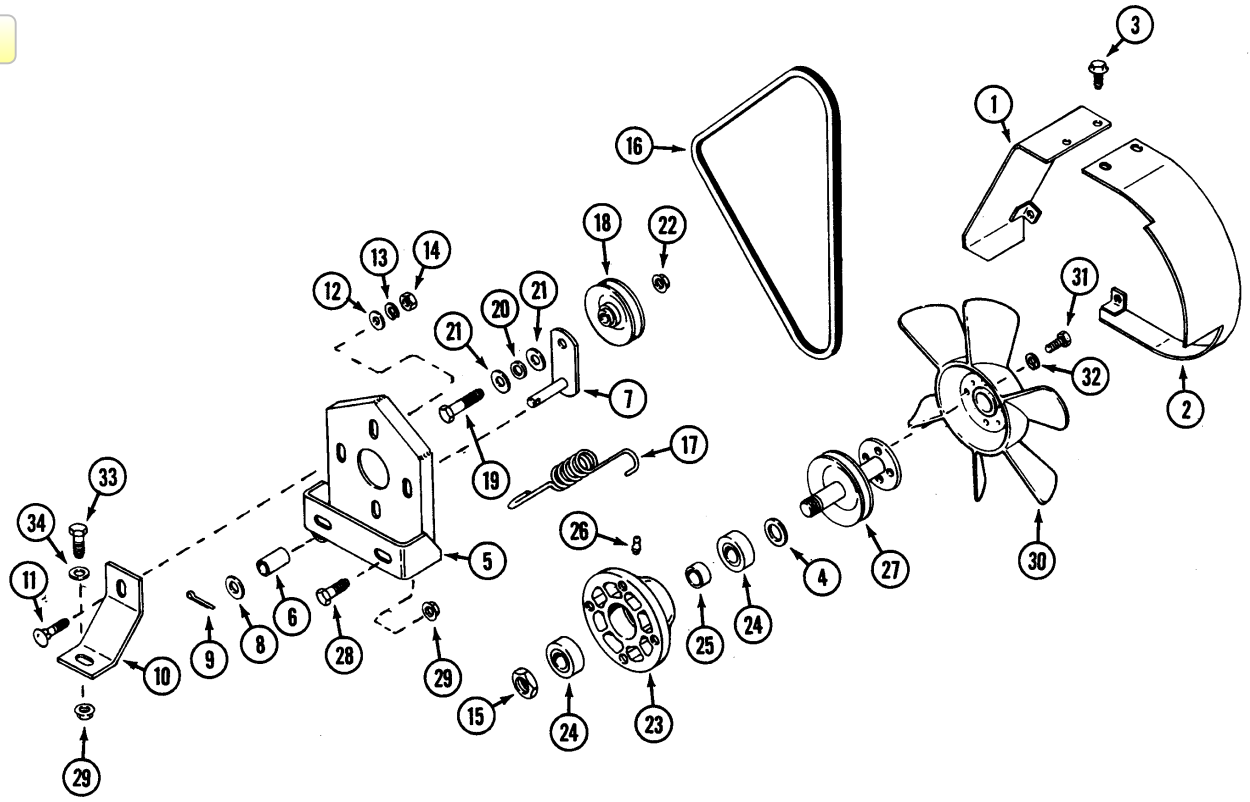

**INDEX**

**RADIATOR FAN ASSEMBLY**

REF.	PART NO.	DESCRIPTION	REQ'D
1	C45436	COWLING - fan, rear .....	1
2	C45439	COWLING - fan, front.....	1
3	187-1036	SCREW - 1/4" - 20 x 1/2" flange .....	6
4	C12975	WASHER - 3/4" - 1-1/8" .....	1
5	C45419	BRACKET - fan mounting .....	1
6	C16714	BUSHING - 1/2" .....	1
7	C45230	ARM - idler .....	1
8	195-2067	WASHER - 1/2" x 7/8" .....	1
9	132-320	PIN - cotter 3/32" x 3/4" .....	1
10	C45205	BRACE - fan mount.....	2
11	111-256	BOLT - 5/16" - 18 x 1-1/4" carriage .....	4
12	195-521	WASHER - .344" x .688" .....	4
13	192-20	LOCKWASHER - 5/16" .....	4
14	129-102	NUT - 5/16" - 18 .....	4
15	131-1331	NUT - 3/4" - 16 lock .....	1
16	C45412	BELT - 3L x 36" .....	1
17	C45413	SPRING - tension.....	1
18	C45338	PULLEY - idler .....	1
19	113-233	BOLT - 3/8" - 16 x 1-3/4" .....	1
20	C30155	WASHER - .39" x .625" .....	1
21	195-525	WASHER - .40"x.81" .....	2
22	131-1352	NUT - 3/8" - 16 flange lock .....	1
23	C45414	HOUSING ASSEMBLY .....	1
24	C28971	BEARING - ball 3/4" .....	2
25	C43208	SPACER - bearing.....	1
26	219-20	FITTING - 1/4" - 28 lubrication .....	1
27	C45415	SPINDLE - fan mounting.....	1
28	113-104	BOLT - 5/16" - 18 x 1-1/4" .....	2
29	131-911	NUT - 5/16" - 18 flange lock .....	4
30	C42984	FAN - 11" .....	1
31	131-1	BOLT - 1/4" - 20 x 1/2" .....	4
32	192-19	LOCKWASHER - 1/4" .....	4
33	113-103	BOLT - 5/16" - 18 x 1" .....	2
34	195-103	WASHER - .375" x .875" .....	2

INDEX

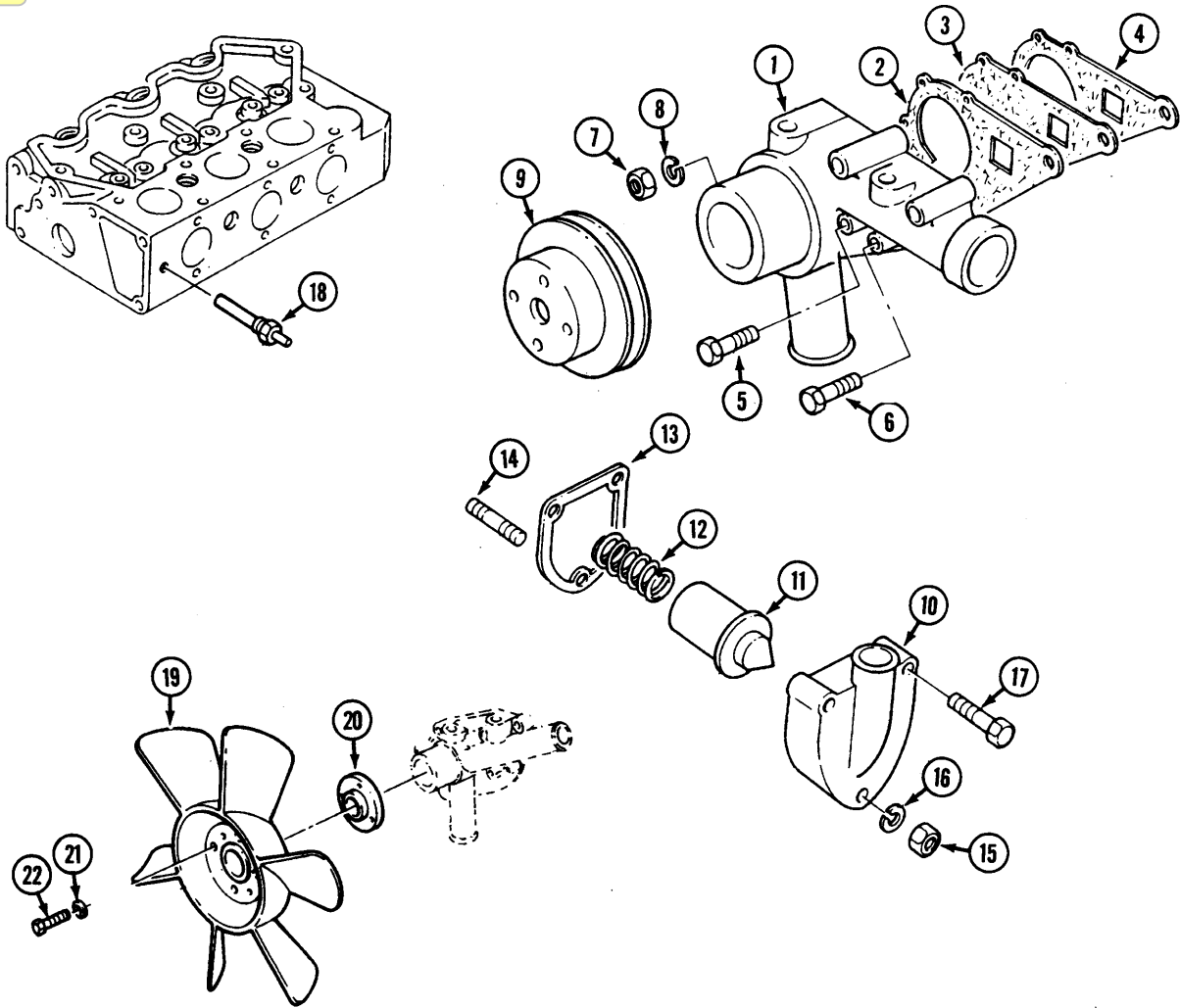



**INDEX**

**WATER PUMP, THERMOSTAT, TEMPERATURE SENDER**

REF.	PART NO.	DESCRIPTION	REQ'D
1	P145016840	PUMP - water.....	1
2	C43617	GASKET.....	1
3	C43618	BACKPLATE.....	1
4	C43619	GASKET.....	1
5	P011300635	SCREW.....	3
6	P011300650	SCREW.....	4
7	P023100006	NUT.....	1
8	P027100006	WASHER.....	1
9	P145336490	PULLEY.....	1
10	P145216161	HOUSING.....	1
11	C43598	THERMOSTAT.....	1
12	C43599	SPRING.....	1
13	C43600	GASKET.....	1
14	P012100650	STUD.....	1
15	P023100006	NUT.....	1
16	P027100006	WASHER.....	1
17	P011300650	SCREW.....	2
18	C43602	SENDER - temperature.....	1
19	C45491	FAN.....	1
20	C42986	SPACER - fan.....	1
21	192-19	LOCKWASHER - 1/4".....	4
22	814-6045	SCREW - M6 - 1.0 x 45.....	4

INDEX

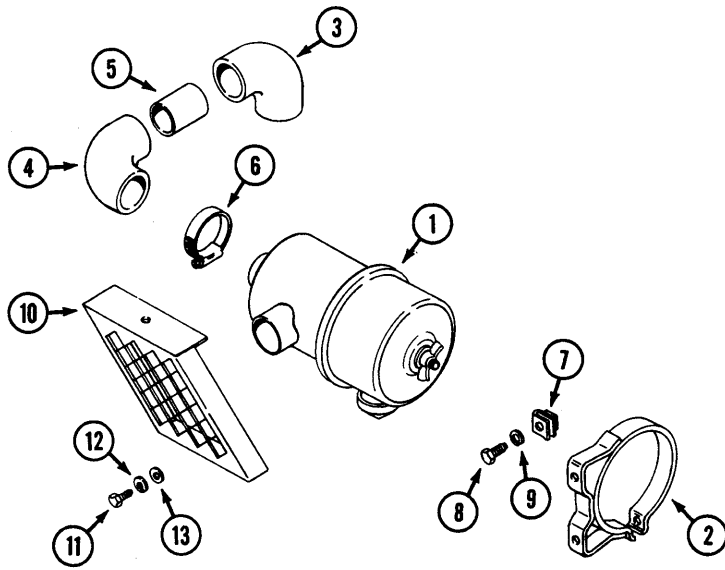

---

INDEX

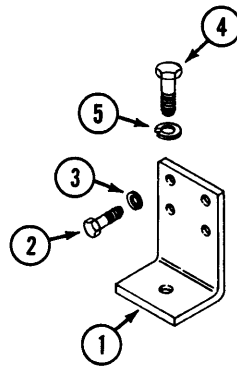

**INDEX**

**AIR CLEANER**

REF.	PART NO.	DESCRIPTION	REQ'D
1	C43030	AIR CLEANER ASSEMBLY.....	1
	C43445	ELEMENT - air cleaner.....	1
	C43594	WING NUT - element.....	1
	C43595	WING NUT - cup.....	1
	C43596	WASHER - cup.....	1
2	C43033	BRACKET - air cleaner.....	1
3	C45305	HOSE - engine.....	1
4	C45340	HOSE - air cleaner.....	1
5	C43366	TUBE - air.....	1
6	214-258	CLAMP - hose.....	4
7	C31973	NUT - "J" 1/4" - 20.....	2
8	113-2	BOLT - 1/4" - 20 x 5/8".....	2
9	192-19	LOCKWASHER - 1/4".....	2
10	C45306	INTAKE - air.....	1
11	113-1	BOLT - 1/4" - 20 x 1/2".....	2
12	192-19	LOCKWASHER - 1/4".....	2
13	195-518	WASHER - 1/4".....	1

**ENGINE MOUNTS**

1	C45303	BRACKET - engine mount.....	2
2	814-10025	BOLT - M10 x 1.5 x 25.....	16
3	192-22	LOCKWASHER - 7/16".....	16
4	113-1	BOLT - 1/2" - 13 x 1-1/4".....	4
5	192-23	LOCKWASHER - 1/2".....	4

INDEX

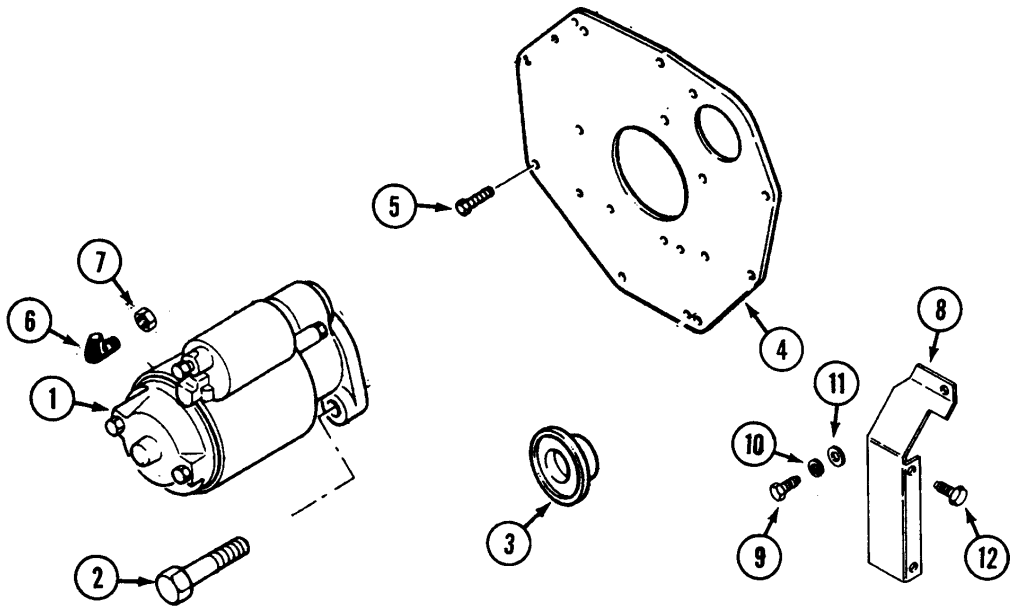

INDEX

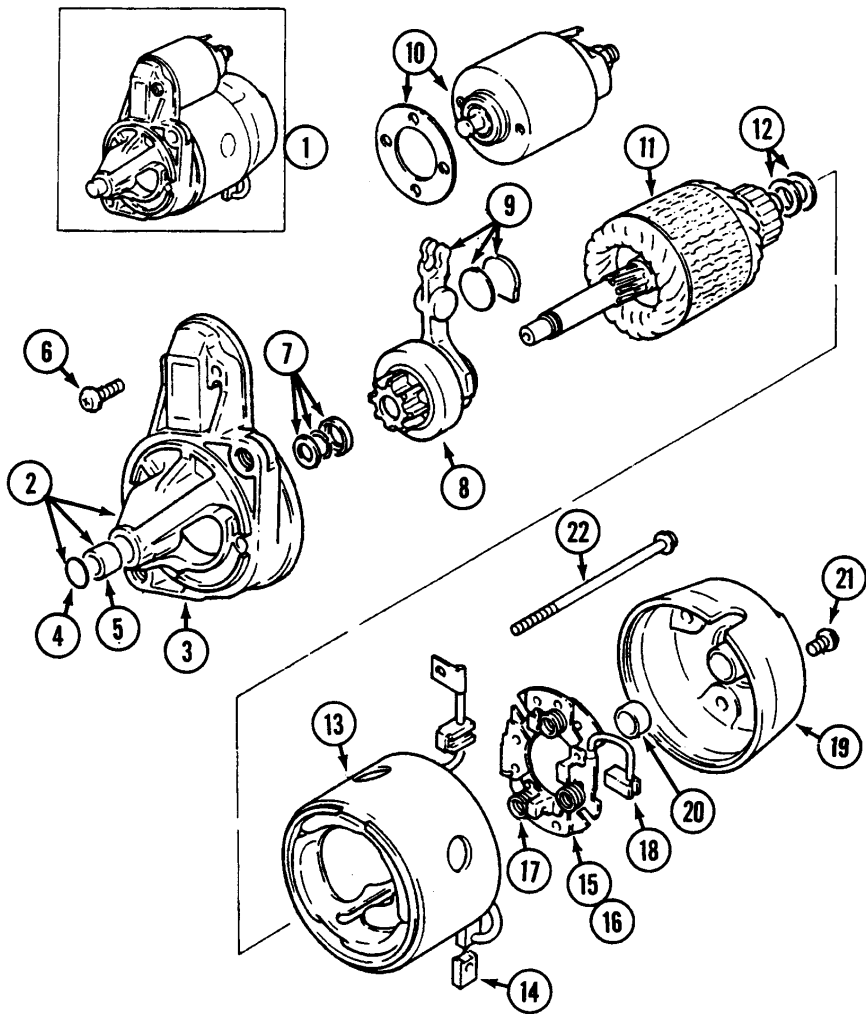

**INDEX****STARTER, PLATE AND FLYWHEEL SHIELD**

REF.	PART NO.	DESCRIPTION	REQ'D
1	C43609	STARTER - repairs below.....	1
2	P011601020	SCREW.....	2
3	P198636080	SEAL - rear.....	1
4	P110366700	PLATE.....	1
5	P011310816	SCREW.....	10
6	C44079	INSULATOR - terminal.....	1
7	C42835	NUT-M8.....	1
8	C43307	SHIELD - flywheel R.H.....	1
9	814-8016	BOLT - M8 - 1.25.....	1
10	192-20	LOCKWASHER - 5/16".....	1
11	195-102	WASHER - 5/16" x 3/4".....	1
12	121-21	BOLT - 1/4" - 20 x 1/2" flange lock.....	2

**INDEX****STARTER ASSEMBLY**

1	C43609	STARTER.....	1
2	P185846471	COVER ASSEMBLY.....	1
3	NSS	COVER.....	1
4	NSS	RING.....	1
5	P185846472	BUSHING.....	1
6	P185846468	SCREW.....	2
7	P185846473	WASHER.....	1
8	P185866240	PINION.....	1
9	P185846469	LEVER.....	1
10	P185816220	SWITCH.....	1
11	P185846474	ARMATURE.....	1
12	P185846475	WASHER.....	1
13	P185846476	YOKE.....	1
14	P185416400	BRUSH.....	1
15	P185416390	HOLDER ASSEMBLY.....	1
16	NSS	HOLDER.....	1
17	P185886010	SPRING.....	1
18	P185416410	BRUSH.....	1
19	P185846477	COVER.....	1
20	P185846478	BUSHING.....	1
21	P185846468	SCREW.....	3
22	P185846470	SCREW.....	2

INDEX

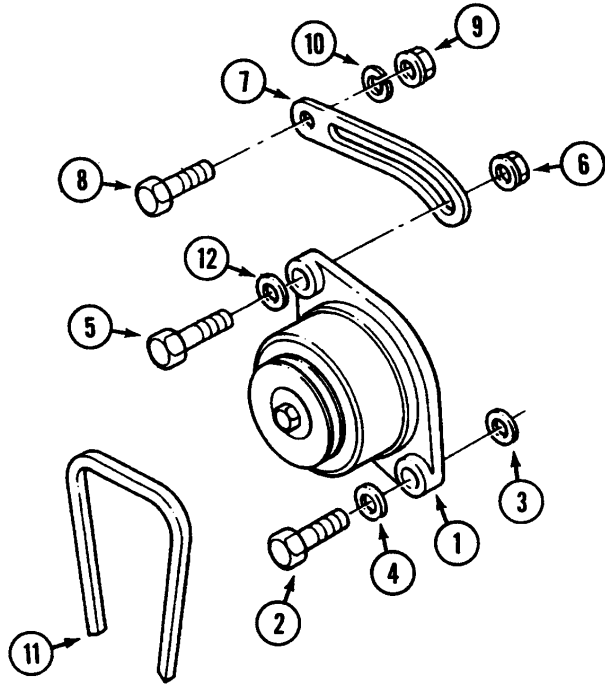

INDEX

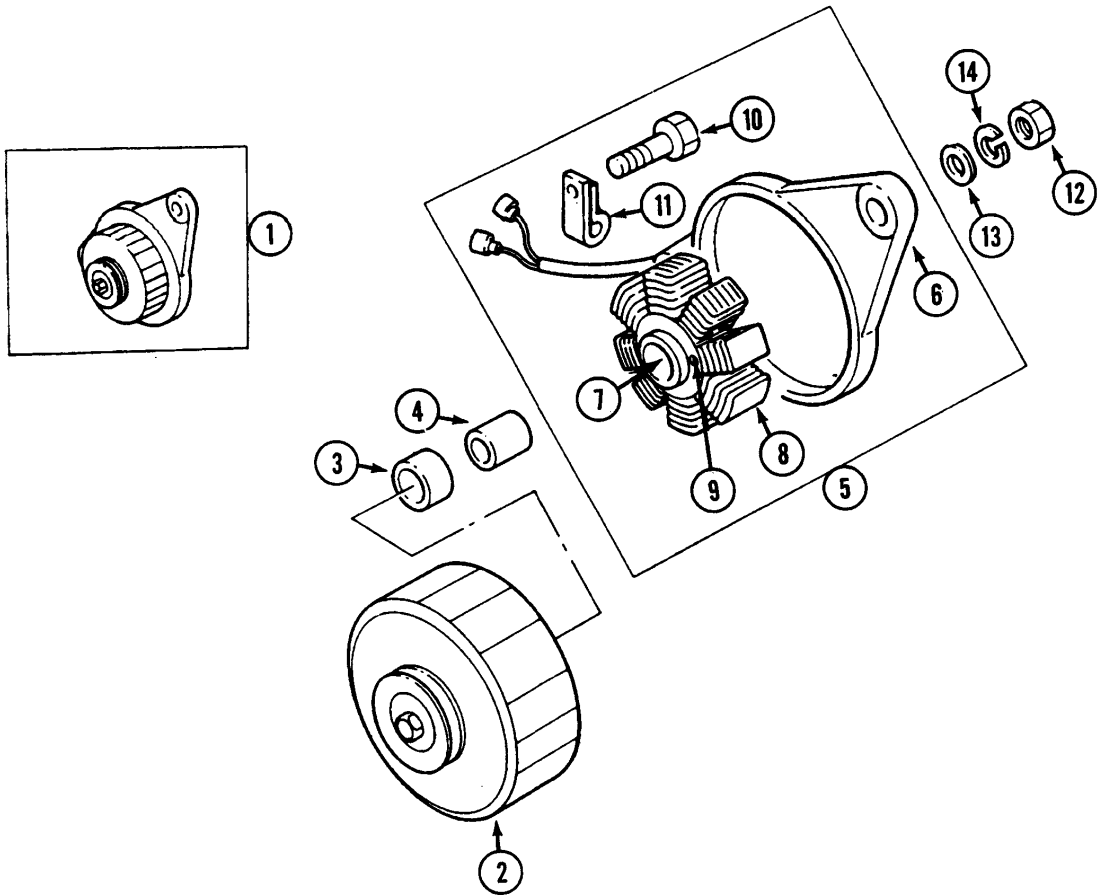

**INDEX**

**ALTERNATOR AND BELT**

REF.	PART NO.	DESCRIPTION	REQ'D
1	C43610	ALTERNATOR - <a href="#">see below for service</a> .....	1
2	P010110850	SCREW .....	1
3	P026109011	WASHER.....	1
4	P026200008	WASHER.....	1
5	P012800840	SCREW .....	1
6	P023100008	NUT .....	1
7	P185726431	LEVER.....	1
8	P011300816	SCREW .....	1
9	P023100008	NUT .....	1
10	P027100008	WASHER.....	1
11	P080109048	BELT .....	1
12	P026109017	WASHER.....	1

**INDEX**

**ALTERNATOR ASSEMBLY**

1	C43610	ALTERNATOR .....	1
2	P185446219	PULLEY .....	1
3	P040126201	BEARING .....	1
4	P199236510	COLLAR .....	1
5	P185446217	PLATE ASSEMBLY .....	1
6	P185716200	PLATE .....	1
7	P040126201	BEARING .....	1
8	P185446218	STATOR .....	1
9	P015140425	SCREW .....	2
10	P015140408	SCREW .....	1
11	P185446220	CLIP .....	5
12	P020210010	NUT.....	1
13	P026100010	WASHER .....	1
14	P027100010	WASHER .....	1

INDEX

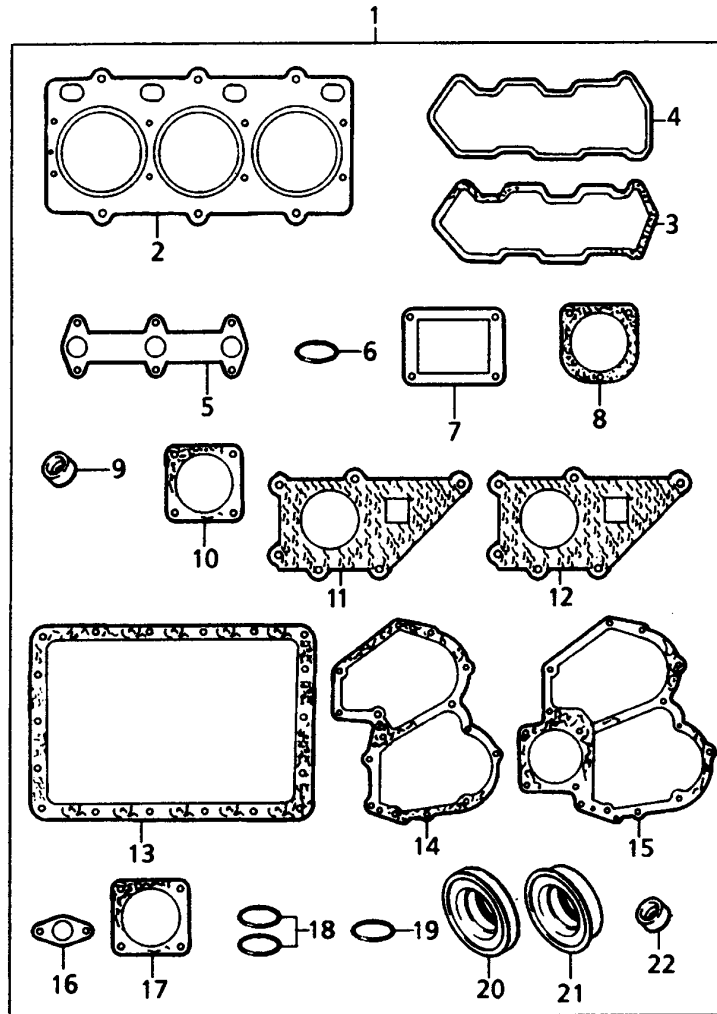



**INDEX**

**GASKET KIT**

REF.	PART NO.	DESCRIPTION	REQ'D
1	P195906840	KIT - gasket, complete .....	1
2	P111147390	GASKET-head .....	1
3	C43615	GASKET - cover .....	1
4	C43616	GASKET - cover .....	1
5	C43988	GASKET - exhaust .....	1
6	C43606	"O" RING - cap.....	1
7	P130996070	GASKET - fuel pump .....	1
8	C43600	GASKET - thermostat.....	1
9	P120406080	SEAL - valve stem .....	3
10	P314990013	GASKET - (not used).....	1
11	C43619	GASKET - water pump .....	1
12	C43617	GASKET - water pump .....	1
13	C43614	GASKET - sump, oil.....	1
14	C43612	GASKET - case .....	1
15	C43613	GASKET - plate .....	1
16	P130996070	GASKET - fuel pump .....	1
17	P165996420	GASKET - plate .....	1
18	C43999	"O" RING - oil tube.....	2
19	P052109076	"O" RING - oil pipe .....	1
20	P198636090	SEAL-case.....	1
21	P198636080	SEAL - plate, rear .....	1
22	P131426200	GASKET - atomizer .....	3

INDEX

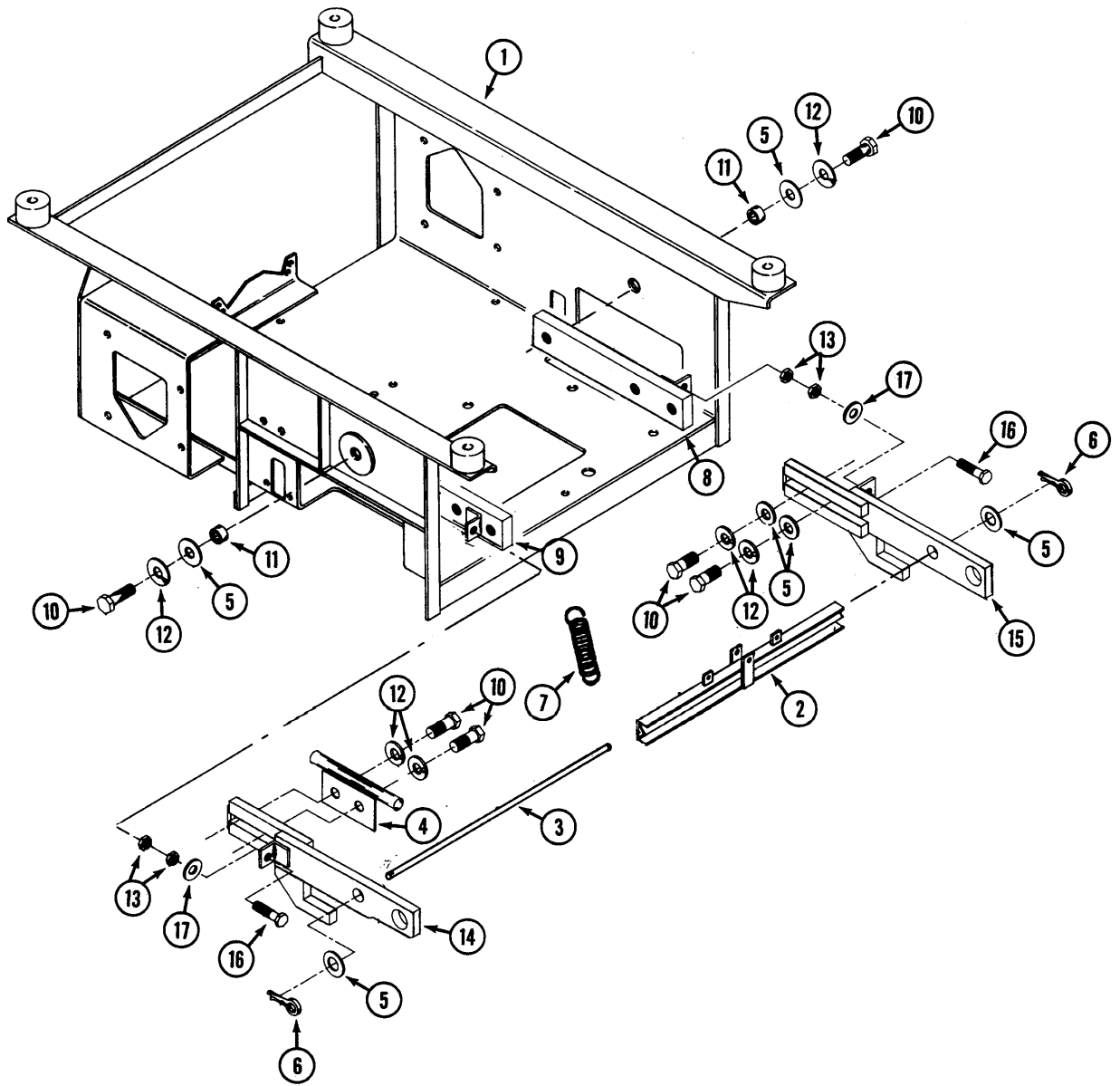

**INDEX**

**BASE AND LIFT ARMS**

REF.	PART NO.	DESCRIPTION	REQ'D
1	C45207	BASE .....	1
2	C37600	BAR - lift .....	1
3	C37578	PIN - lift bar .....	1
4	C37577	TUBE - wire .....	1
5	195-106	WASHER - .56" x 1.38" .....	6
6	132-310	PIN - cotter .....	2
7	C37815	SPRING - deck lift .....	2
8	C38996	ARM - deck lift, rear L.H. ....	1
9	C39006	ARM - deck lift, rear R.H. ....	1
10	113-417	BOLT - 1/2"-13 x1-1/4" .....	6
11	C37576	BUSHING - .38" .....	2
12	192-23	LOCKWASHER - 1/2" .....	6
13	129-103	NUT - 3/8" - 16 .....	4
14	C37573	ARM - deck lift, front R.H. ....	1
15	C37574	ARM - deck lift, front, L.H. ....	1
16	113-241	BOLT - 3/8" - 16 x 3" .....	2
17	195-104	WASHER - 3/8" .....	2

INDEX

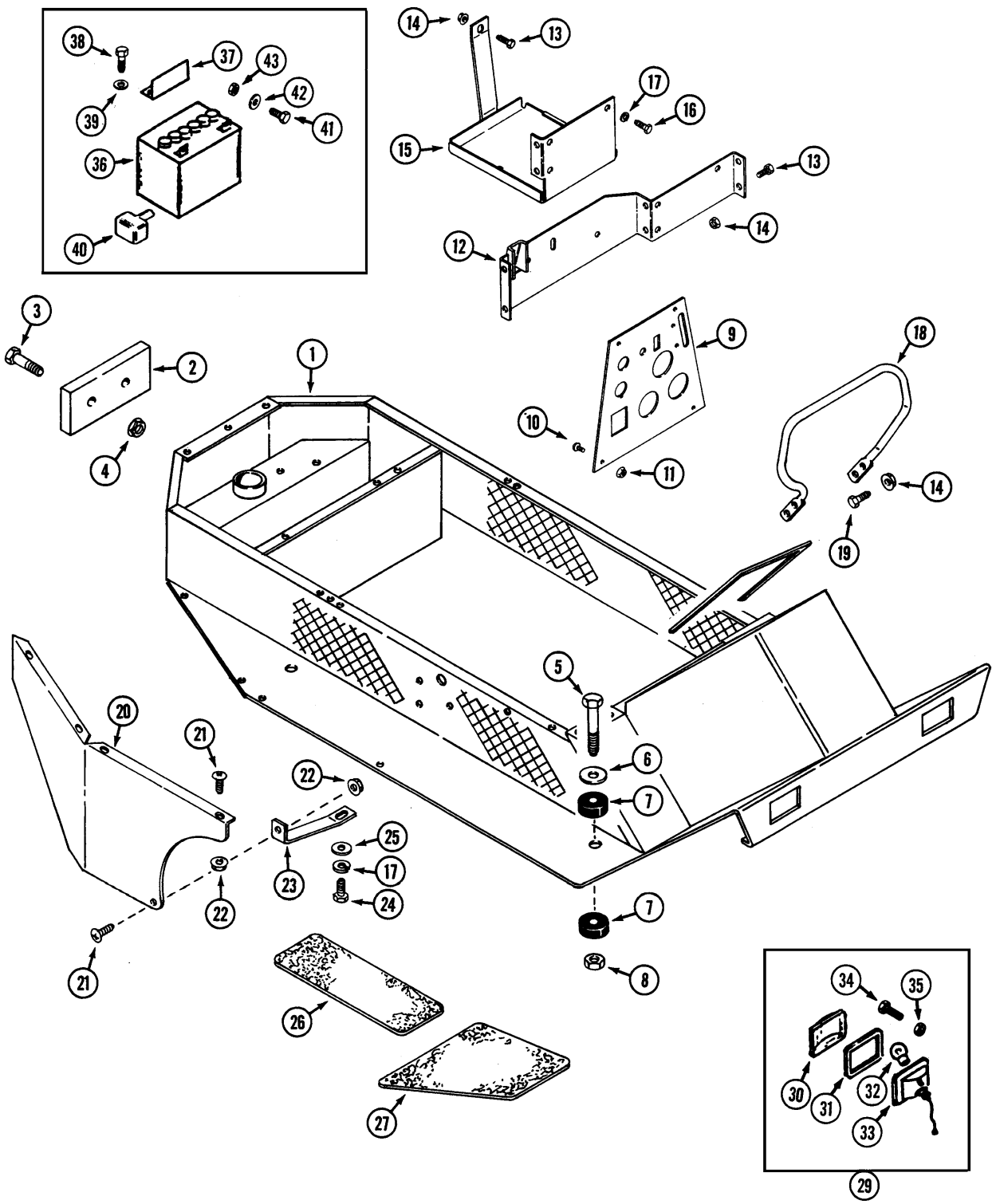

**INDEX**

**BODY AND ATTACHING PARTS**

REF.	PART NO.	DESCRIPTION	REQ'D
1	C45252	BODY .....	1
2	C45299	PLATE - weight .....	4
3	113-248	BOLT - 3/8" - 16 x 2-3/4" .....	4
4	131-1352	NUT - 3/8" - 16 flange lock .....	4
5	113-429	BOLT - 1/2" - 13 x 5" .....	4
6	C37581	WASHER - 1/2" x 2" .....	4
7	C37818	MOUNT - rubber, body.....	8
8	131-70	NUT - 1/2" - 13 lock .....	4
9	C45164	PANEL - instrument .....	1
10	182-573	SCREW - #10 - 24 x 1/2" .....	4
11	C34117	NUT - #10 - 24 flange lock .....	2
12	C45354	CROSSM EMBER - body.....	1
13	113-118	BOLT - 5/16" - 18 x 5/8" .....	5
14	131-911	NUT - 5/16" - 18 flange lock .....	9
15	C45349	TRAY - battery .....	1
16	113-101	BOLT-5/16"-18x1/2" .....	5
17	192-20	LOCKWASHER-5/16" .....	7
18	C44844	RAIL - guard .....	1
19	113-102	BOLT - 5/16" - 18 x 3/4" .....	4
20	C45346	SKIRT - fender L.H.....	1
20	C45347	SKIRT - fender R.H. (shown) .....	1
21	182-547	SCREW - 1/4" - 20 x 1/2" .....	10
22	131-934	NUT - 1/4" - 20 flange lock .....	10
23	C45348	BRACE - fender .....	2
24	113-103	BOLT - 5/16" - 18 x 1" .....	2
25	195-103	WASHER - 3/8" x 7/8" .....	2
26	C43382	PAD - footrest, side .....	2
27	C43419	PAD - foot, front L.H.....	1
27	C43420	PAD - foot, front R.H. (shown) .....	1
28	C44035	TRIM - instrument panel.....	1
29	C32178	HEADLIGHT.....	2
30	C22573	LENS.....	1
31	C14304	GASKET .....	1
32	C28932	BULB.....	1
33	NSS	REFLECTOR .....	1
34	113-4	BOLT - 1/4" - 20 x 1" .....	2
35	129-101	NUT - 1/4" -20 .....	2
36	C44071	BATTERY - 12V, 450 CCA .....	1
37	C44004	RETAINER - battery.....	1
38	113-17	BOLT - 1/4" - 20 x 1-1/4" .....	1
39	195-518	WASHER - .28" x .62" .....	1
40	C43046	INSULATOR - post.....	1
41	113-3	BOLT - 1/4" - 20 x 3/4" .....	2
42	195-102	WASHER - 1/4" .....	2
43	131-71	NUT - 1/4" - 20 lock.....	2

INDEX

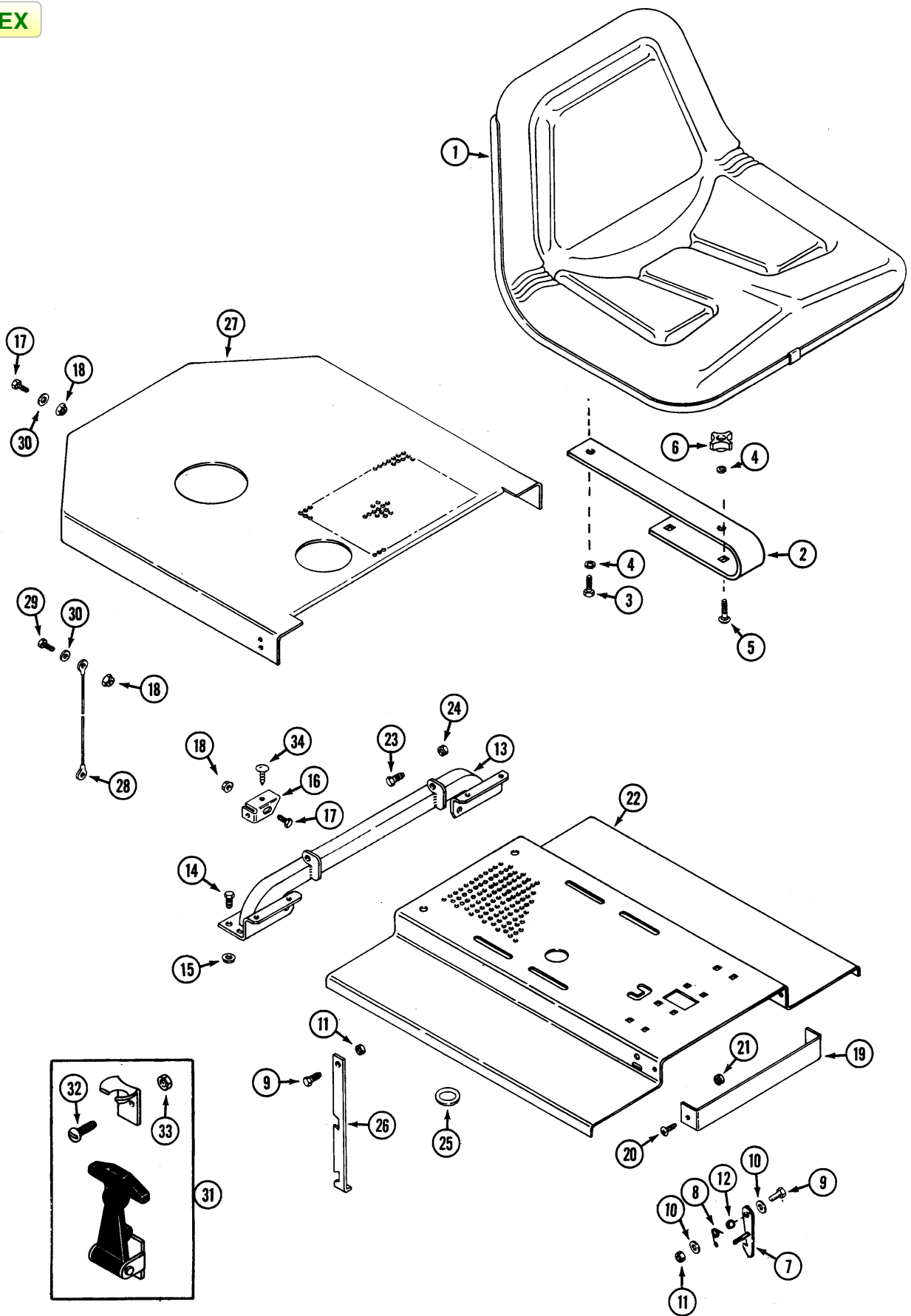

**INDEX**

**SEAT, LID AND REAR COVER**

REF.	PART NO.	DESCRIPTION	REQ'D
1	C43202	SEAT .....	1
2	C43137	SPRING-seat .....	2
3	113-102	BOLT - 5/16" -18 x 3/4" .....	4
4	192-20	LOCKWASHER - 5/16" .....	8
5	111-204	BOLT - carriage 5/16" - 18 x 1-1/4" .....	4
6	C43438	KNOB - seat adjust .....	4
7	C44481	LATCH - lid.....	1
8	C37851	SPRING - latch.....	1
9	113-4	BOLT - 1/4" - 20 x 1" .....	2
10	195-102	WASHER - 1/4" .....	2
11	131-71	NUT - 1/4" - 20 lock.....	2
12	C44498	SPACER - latch.....	1
13	C45318	TUBE - seat support.....	1
14	113-118	BOLT - 5/16" - 18 x 5/8" .....	4
15	131-911	NUT - 5/16" - 18 flange lock.....	4
16	C45336	BRACKET - retainer R.H. (shown).....	1
16	C45337	BRACKET - retainer L.H .....	1
17	113-1	BOLT - 1/4" - 20 x 1/2" .....	4
18	131-934	NUT - 1/4" - 20 flange lock .....	4
19	C37826	PLATE - filler .....	1
20	182-528	SCREW - #10 - 32 x 1/2" .....	2
21	193-1000	NUT - #10-32 lock .....	2
22	C45352	LID - seat.....	1
23	113-103	BOLT - 5/16" - 18 x 1" .....	2
24	131-69	NUT - lock .....	2
25	C25165	GROMMET - 1" x 1-3/4" .....	1
26	C45471	PROP - seat lid .....	1
27	C45300	COVER - rear.....	1
28	C45472	LANYARD .....	1
29	113-3	BOLT - 1/4" - 20 x 3/4" .....	1
30	195-518	WASHER - .281" x .625 .....	3
31	C43326	LATCH - "T" handle.....	2
32	182-571	SCREW - #6 - 32 x 1/2" .....	8
33	193-1003	NUT - #6 - 32 lock .....	8
34	C35067	RETAINER - plastic.....	12

INDEX

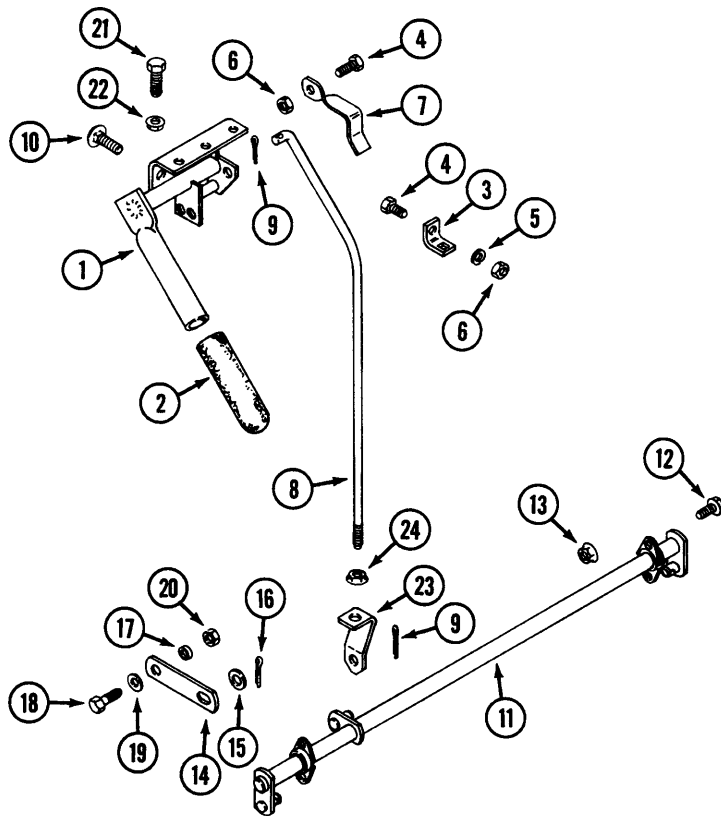

INDEX

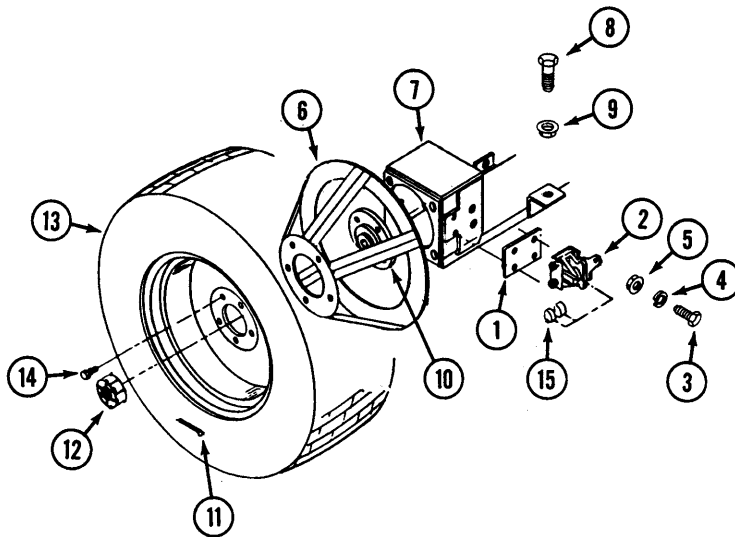



**INDEX****PARKING BRAKE**

REF.	PART NO.	DESCRIPTION	REQ'D
1	C45370	LEVER - brake .....	1
2	C37631	GRIP - handle .....	1
3	C45387	STOP - lever .....	1
4	113-3	BOLT - 1/4" - 20 x 3/4" .....	2
5	192-19	LOCKWASHER - 1/4" .....	2
6	129-101	NUT - 1/4" - 20 .....	3
7	C45432	ARM - actuator .....	1
8	C45375	ROD - brake .....	1
9	132-310	PIN - cotter 1/8" x 1" .....	2
10	111-111	BOLT - 1/4" - 20 x 1" carriage .....	1
11	C45324	SHAFT - cross.....	1
12	187-1036	BOLT - 1/4" - 20 x 1/2" flange .....	4
13	131-934	NUT - 1/4" - 20 flange lock .....	4
14	C45503	BAR - brake link .....	2
15	195-525	WASHER - .40" x .81" .....	2
16	132-321	PIN - cotter 1/8" -1.....	2
17	C42895	BUSHING .....	2
18	113-4	BOLT - 1/4" - 20 x 1" .....	2
19	195-102	WASHER - .31" x .75" .....	2
20	131-71	NUT - 1/4" - 20 lock.....	2
21	113-118	BOLT - 5/16" - 18 x 5/8" .....	1
22	131-911	NUT - 5/16" - 18 flange lock.....	1
23	C45501	CLEVIS - brake .....	1
24	131-938	NUT - 3/8" - 18 flange lock.....	1

**INDEX****DRIVE WHEELS**

1	C45277	MOUNT - caliper .....	2
2	C45485	BRAKE - caliper L.H.....	1
2	C45486	BRAKE - caliper R.H.....	1
3	113-102	BOLT - 5/16" - 18 x 3/4" .....	8
4	192-20	LOCKWASHER - 5/16" .....	4
5	131-911	NUT - 5/16" - 18 flange lock.....	4
6	C37611	DISC - brake .....	2
7	C45274	AXLE - drive .....	1
8	113-417	BOLT - 1/2" - 13 x 1-1/4" (axle mounting) .....	6
9	131-930	NUT - 1/2" - 13 flange lock (axle mounting) .....	6
10	C44847	HUB - mounting.....	2
11	132-337	PIN - cotter 1/8" x 1-3/4".....	2
12	C37628	NUT - hub.....	2
13	NSS	WHEEL ASSEMBLY - 20 x 10-10.....	2
	C44850	RIM .....	1
14	C44848	BOLT - lug 1/2" - 20 x 1" .....	10
15	C37627	PUCKS - brake (1 pair) .....	2

INDEX

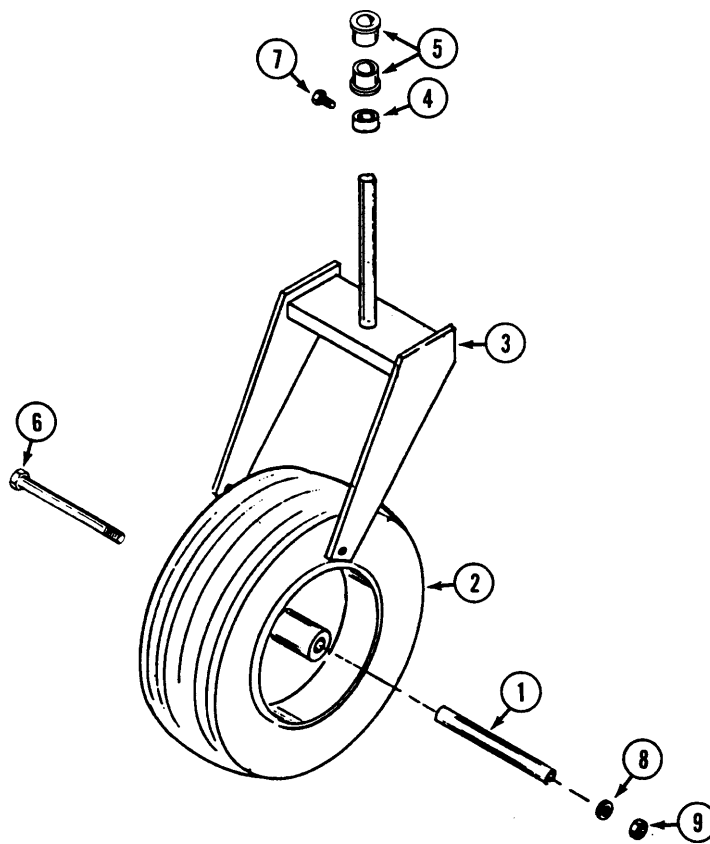

**INDEX**

**SINGLE TAIL WHEEL**

REF.	PART NO.	DESCRIPTION	REQ'D
1	C37854	AXLE - wheel .....	1
2	C37855	WHEEL ASSEMBLY - tail .....	1
	C37856	BEARING - wheel .....	2
	C37857	TIRE - 15 x 6.50-8 .....	8
	C37858	RIM - 8" .....	1
3	C45297	FORK - tail wheel .....	1
4	C37860	COLLAR - set 1" .....	1
5	C37861	SPACER - tail wheel fork .....	1
6	113-452	BOLT - 1/2" - 13 x 9-1/2" .....	1
7	85-58	SCREW -set 5/16" - 18 x 1/2" square head .....	1
8	192-23	LOCKWASHER - 1/2" .....	1
9	129-105	NUT - 1/2" - 13 .....	1
10	C37824	BEARING - ball 1" .....	2
	219-20	FITTING - grease 1/4" - 28 (caster pivot).....	1

INDEX

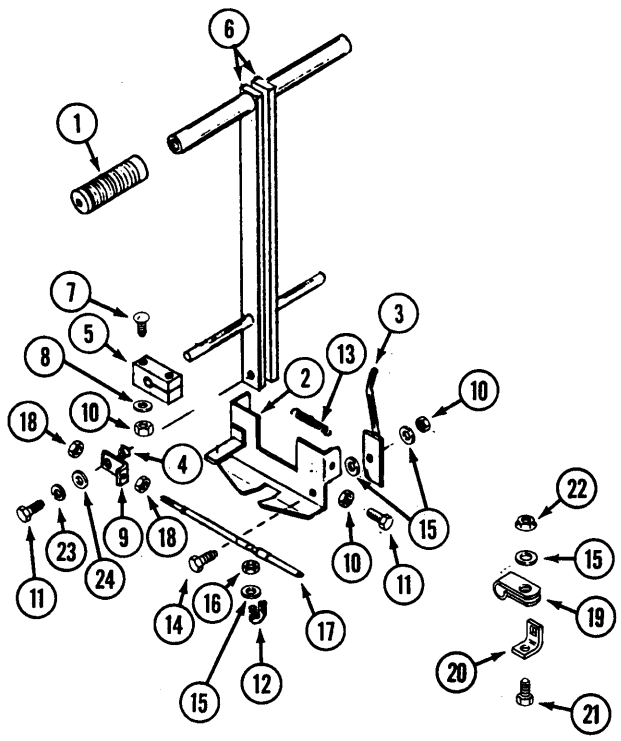

INDEX

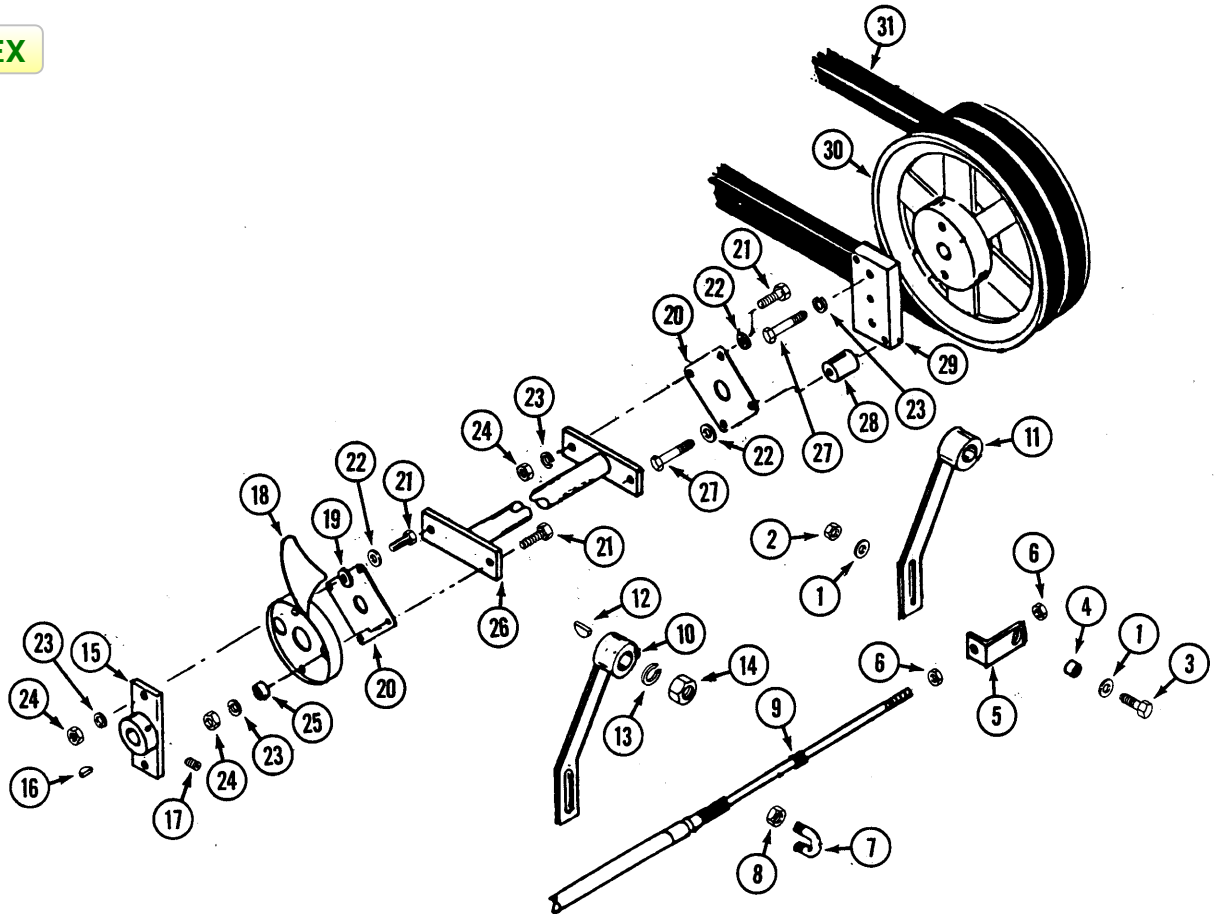

**INDEX****STEERING**

REF.	PART NO.	DESCRIPTION	REQ'D
1	C37631	GRIP - handle .....	2
2	C37840	BRACKET - lever lock.....	1
3	C37841	LATCH - lever lock.....	1
4	C42895	BUSHING - steering cable .....	2
5	C37842	BLOCK - bearing.....	2
6	C44915	LEVER - steering .....	2
7	111-114	BOLT - 1/4" - 20 x 1-1/2" carriage.....	8
8	195-102	WASHER - 1/4" .....	8
9	C37713	BRACKET - steering cable end .....	2
10	131-71	NUT - 1/4" - 20 lock.....	11
11	113-3	BOLT - 1/4" - 20 x 3/4" .....	4
12	C37718	CLAMP - cable .....	2
13	C37837	SPRING - lever lock.....	1
14	C42359	BOLT - 1/4" - 20 x 2" .....	1
15	195-102	WASHER - 1/4" .....	7
16	131-69	NUT - 5/16" - 18 lock.....	4
17	C43180	CABLE - steering .....	2
18	193-1001	NUT - 1/4" - 28" .....	4
19	C33218	CLAMP .....	2
20	C45387	STOP - brake lever .....	1
21	113-1	BOLT - 1/4" - 20 x 1/2" .....	1
22	131-934	NUT - 1/4" - 20 flange lock.....	1
23	192-19	LOCKWASHER - 1/4" .....	2
24	195-520	WASHER - 1/4" .....	2

**INDEX****TRANSMISSION CONTROLS AND CROSS SHAFT**

1	195-520	WASHER - 1/4" .....	4
2	131-71	NUT - 1/4" - 20 lock.....	2
3	113-4	BOLT - 1/4" - 20 x 1" .....	2
4	C42895	BUSHING - steering cable .....	2
5	C37713	BRACKET - steering cable end .....	2
6	193-1001	NUT - 1/4" - 20 lock.....	4
7	C37718	CLAMP - cable .....	2
8	131-69	NUT - 5/16" - 18 lock.....	4
9	C43180	CABLE - steering .....	2
10	C45233	ARM - control L.H.....	1
11	C45234	ARM - control R.H.....	1
12	126-11	KEY - 1/8" x 5/8" woodruff.....	2
13	192-23	LOCKWASHER - 1/2" .....	2
14	129-105	NUT - 1/2" - 13 .....	2
15	C37708	HUB - drive.....	1
16	126-16	KEY - 3/16" x 3/4" woodruff.....	2
17	83-55	SETSCREW - 5/16" - 18 x 5/16" .....	2
18	C37696	FAN .....	1
19	C37704	WASHER - .33" x .69" x .13" .....	2
20	C37700	PLATE - drive.....	2
21	113-103	BOLT - 5/16" - 18 x 1" .....	6
22	195-102	WASHER - .312" x .75" .....	6
23	192-20	LOCKWASHER - 5/16" .....	8
24	129-102	NUT - 5/16" - 18 .....	6
25	C37702	SPACER - 1/4 .....	2
26	C38015	SHAFT - cross.....	1
27	113-104	BOLT - 5/16" - 18 x 1-1/4" .....	4
28	C45378	SPACER - 3/4" .....	2
29	C37710	BLOCK - cross shaft .....	1
30	C45154	PULLEY - pump drive .....	1
31	C37716	BELT - engine to transmission.....	1

INDEX

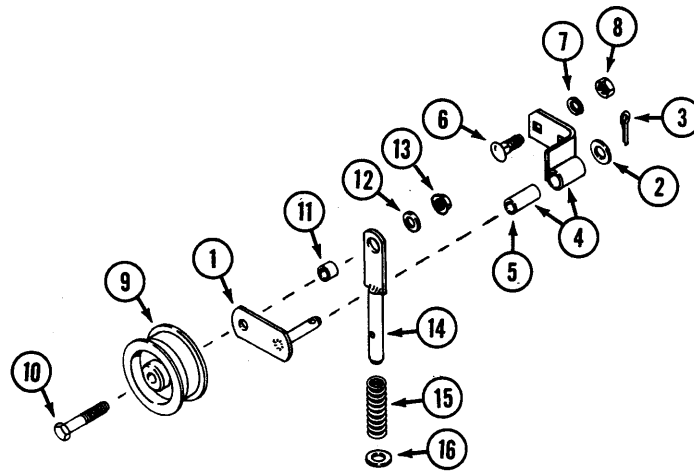

INDEX

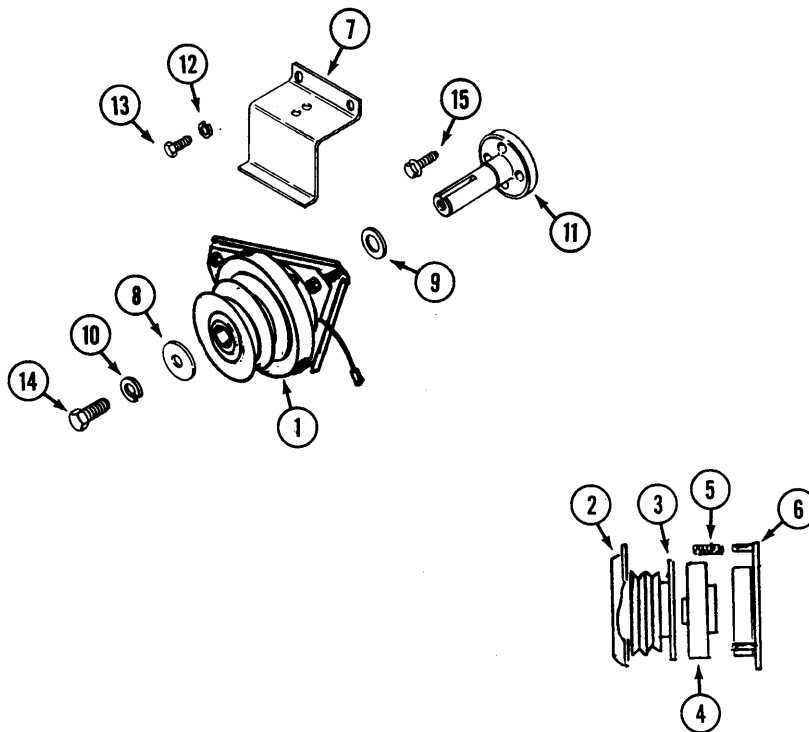

**INDEX****DRIVE IDLER**

REF.	PART NO.	DESCRIPTION	REQ'D
1	C45230	ARM - idler .....	1
2	195-2067	WASHER - 1/2" x 7/8" .....	1
3	132-320	PIN - cotter 3/32" x 3/4" .....	1
4	C45400	BRACKET - pivot (includes bushing) .....	1
5	C16714	BUSHING - .50" x .62" x 1.5" .....	1
6	111-342	BOLT - carriage 3/8" - 16 x 1" .....	2
7	192-21	LOCKWASHER - 3/8" .....	2
8	129-103	NUT - 3/8" - 16 .....	2
9	C38445	PULLEY - 3.25" x 1.38" .....	1
10	113-213	BOLT - 3/8" - 16 x 2-1/4" .....	1
11	C16573	SPACER - .38" x .62" x .41" .....	1
12	195-525	WASHER - 3/8" .....	2
13	131-1352	NUT - 3/8" - 16 flange lock .....	1
14	C45403	GUIDE - spring .....	1
15	C45407	SPRING - compression .....	1
16	C44383	WASHER - thrust .....	1

**INDEX****ELECTRIC CLUTCH (PTO)**

1	C37569	CLUTCH - electric .....	1
2	C37549	BRAKE - clutch .....	1
3	C37570	ARMATURE - clutch .....	1
4	C37551	ROTOR - clutch .....	1
5	C37552	KIT - spring and nut (3 each) .....	1
6	C37553	COIL - clutch .....	1
7	C45357	BRACKET - clutch stop .....	1
8	C31615	WASHER - .47" x 1.75" x 1/4" .....	1
9	C13716	WASHER - thrust 1" x 1.5" .....	1
10	192-21	LOCKWASHER - 3/8" .....	1
11	C44009	ADAPTER - clutch .....	1
12	192-20	LOCKWASHER - 5/16" .....	2
13	814-8016	BOLT - M8 - 1.25 x 16 .....	2
14	114-201	BOLT - 3/8" - 24 x 1-1/4" .....	1
15	C42828	SCREW - M10 - 1.25 x 34 .....	4

INDEX

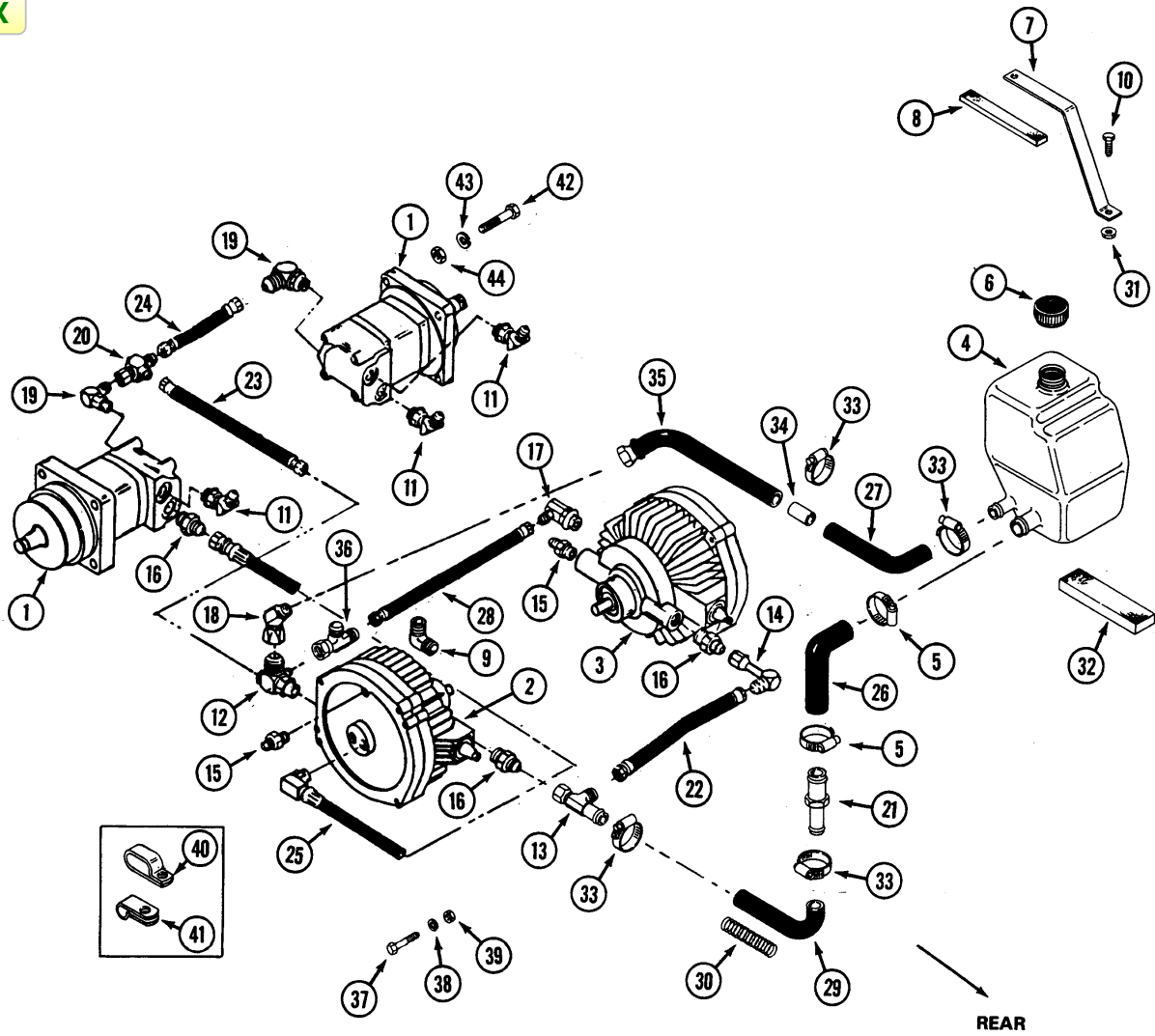



**INDEX**

**HYDRAULIC SYSTEM (DRIVE)**

REF.	PART NO.	DESCRIPTION	REQ'D
1	C37667	WHEEL MOTOR .....	2
2	C44376	PUMP - L.H. CW (Eaton No. 1120-016) .....	1
3	C44375	PUMP - R.H. CCW (Eaton No. 1120-017) .....	1
4	C37228	TANK - hydraulic oil .....	1
5	214-255	HOSE CLAMP - #16 (for 1" hose).....	2
6	C37093	CAP ASSEMBLY - tank .....	1
7	C45317	BRACKET - hold down.....	1
8	C34189	CUSHION - tank.....	3
9	218-5105	FITTING - 90° 9/16" .....	1
10	113-3	BOLT - 1/4" - 20 x 3/4" .....	2
11	218-5146	FITTING - male tube, 45° male O-ring adapter .....	3
12	C37678	FITTING - special cross .....	1
13	C45284	FITTING - tee .....	1
14	C37680	FITTING - male tube, 90° female swivel adapter.....	1
1 5	218-5057	FITTING - male tube, male O-ring adapter.....	4
16	218-5060	FITTING - male tube, male O-ring adapter.....	3
17	218-5121	FITTING - male tube, 90° male O-ring adapter .....	1
18	218-5175	FITTING - male tube, 45° female swivel adapter.....	1
19	218-5103	FITTING - male tube, 90° male O-ring adapter .....	2
20	218-5478	FITTING - male tube, female swivel tee .....	1
21	C45283	CONNECTOR - 3/4" x 1".....	1
22	C45290	HOSE - 3/4" x 18" long.....	1
23	C45295	HOSE - 1/4" ID x 14" long, easy couple.....	1
24	C45293	HOSE - 7/16" x 18" long.....	1
25	C44465	HOSE - 1/2" ID x 36-1/2" long (L.H. pump).....	2
25	C45286	HOSE - 1/2" ID x 26-1/2" long (R.H. pump) .....	2
26	C33551	HOSE - suction 90° x 1" .....	1
27	C43372	HOSE - 90° x 3/4" .....	1
28	C37693	HOSE - 1/2" ID x 20" long, easy couple.....	1
29	C44286	HOSE - 3/4" x 9".....	1
30	C15564	SPRING - hose liner.....	1
31	131-934	NUT - 1/4" - 20 flange lock .....	2
32	C44584	FOAM - cushion .....	3
33	214-254	CLAMP - hose #12 (for 3/4" hose) .....	5
34	C43377	TUBE - connector 3/4" x 1-1/2" .....	1
35	C45289	HOSE - 3/4" x 14-1/4" .....	1
36	218-845	FITTING - tee 3/4" .....	1
37	113-257	BOLT - 3/8" - 16 x 2-1/2" .....	1
38	192-21	LOCKWASHER - 3/8" .....	8
39	129-103	NUT - 3/8" - 16 .....	8
40	C33213	CLAMP - double tube.....	2
41	C33218	CLAMP - single tube .....	1
42	113-421	BOLT - 1/2" - 13 x 2" .....	8
43	192-23	LOCKWASHER - 1/2" .....	8
44	129-105	NUT - 1/2" - 13 .....	8

INDEX

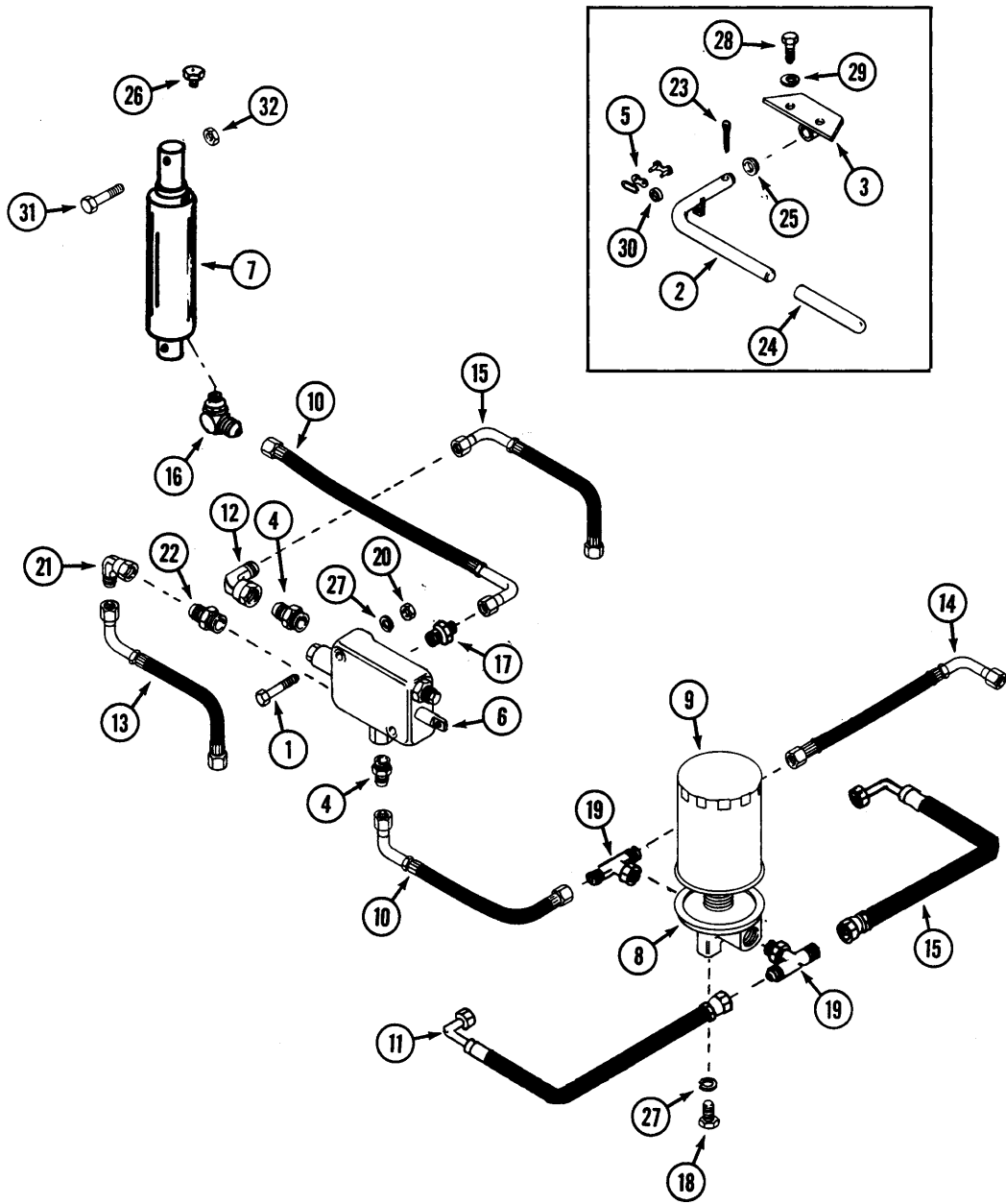

**INDEX**

**HYDRAULIC LIFT ASSEMBLY**

REF.	PART NO.	DESCRIPTION	REQ'D
1	113-14	BOLT - 1/4" -20 x 2" .....	2
2	C45341	LEVER - actuator .....	1
3	C45343	PIVOT - lever .....	1
4	218-5058	FITTING - 9/16" x 3/4" .....	2
5	C37791	CONNECTING LINK - #50 .....	1
6	C42937	VALVE - lift .....	1
7	C44030	CYLINDER - lift .....	1
8	C37636	HOUSING - oil filter .....	1
9	C37637	ELEMENT - oil filter .....	1
10	C37794	HOSE - 3/8" ID x 26" long .....	2
11	C37795	HOSE - 3/8" ID x 31" long .....	1
12	218-980	FITTING - 90° 9/16" .....	1
13	C45292	HOSE - 90°, 3/4" x 19" .....	1
14	C45287	HOSE - 3/8" ID x 11.5" long .....	1
15	C37799	HOSE - 3/8" ID x 21" long .....	1
16	218-5278	FITTING - 90° male tube adapter .....	2
17	218-5057	FITTING - straight .....	3
18	113-2	BOLT - 1/4" - 20 x 5/8" .....	2
19	218-5182	FITTING-tee .....	1
20	129-101	NUT - 1/4" - 20 .....	2
21	218-5230	FITTING - 90°, 3/4" .....	1
22	218-5059	FITTING - straight .....	1
23	132-310	PIN - cotter 1/8" x 1" .....	1
24	C26020	GRIP - handle .....	1
25	C37787	GROMMET - lever .....	1
27	192-19	LOCKWASHER - 1/4" .....	4
28	113-101	BOLT - 5/16" - 18 x 1/2" .....	2
29	192-20	LOCKWASHER - 5/16" .....	2
30	C42895	BUSHING .....	2
31	113-422	BOLT - 1/2" - 13 x 2-1/2" .....	1
32	131-70	NUT - 1/2" - 13 lock .....	1

# INDEX

## COLOR CODE

- BR - Brown
- B - Black
- G/B - Green/Black
- BL/W - Blue/White
- R/B - Red/Black
- R/W - Red/White
- G - Green
- B/W - Black/White
- BL - Blue
- Y/B - Yellow/Black
- G - Gray
- L/BL - Lite Blue
- D/BL - Dark Blue
- L/G - Lite Green
- R - Red
- T - Tan
- W - White
- Y - Yellow

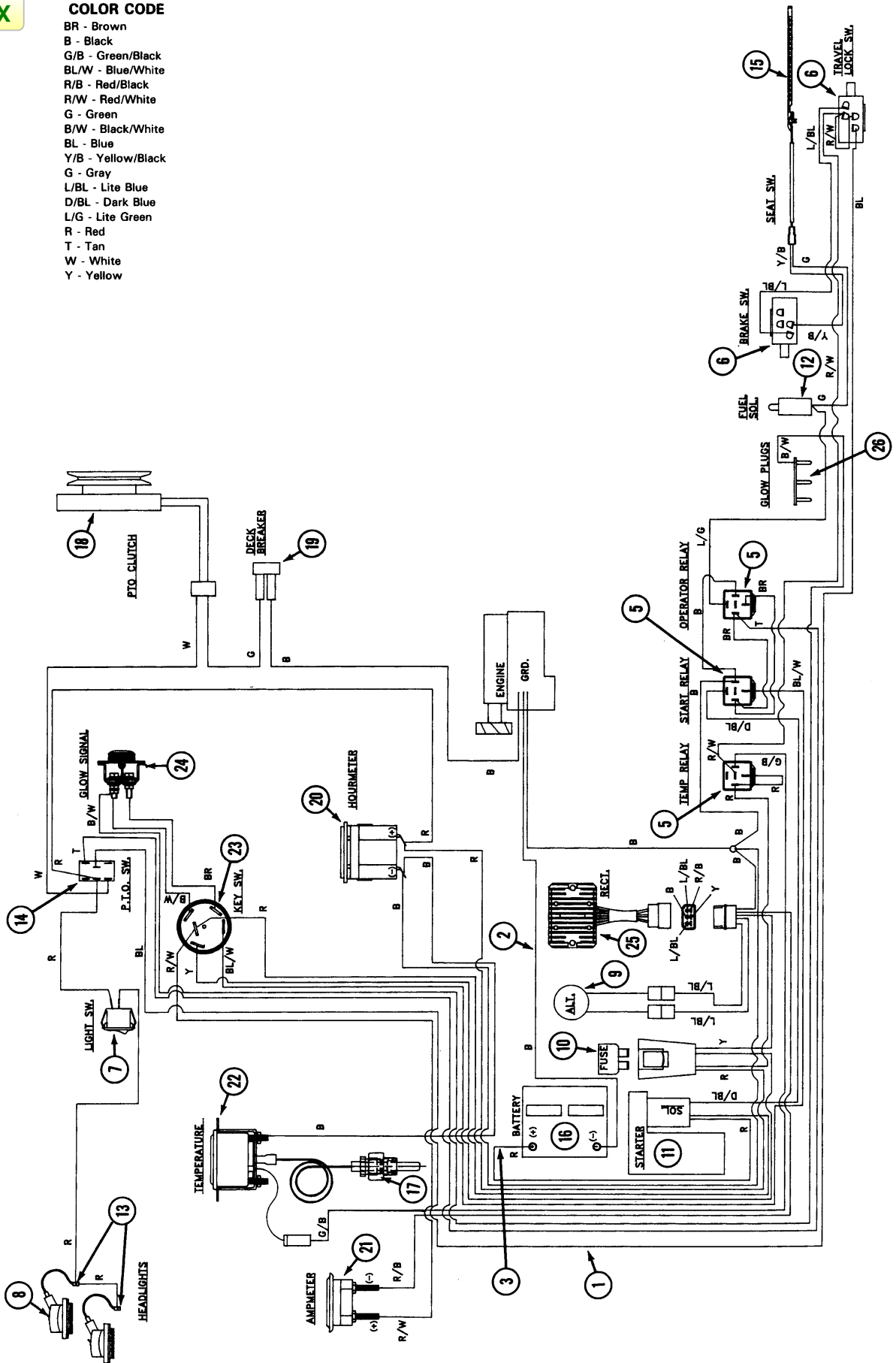

**INDEX**

**ELECTRICAL SYSTEM**

REF.	PART NO.	DESCRIPTION	REQ'D
1	C45359	HARNESS - main.....	1
2	C43350	CABLE - battery (—).....	1
3	C43349	CABLE - battery (+).....	1
4	C43046	INSULATOR - battery post.....	1
5	C37515	RELAY.....	3
	182-573	SCREW - #10 - 24 x 1/2" (relay mount).....	3
	192-18	LOCKWASHER - #10 (relay mount).....	3
6	C37521	SWITCH - 2 circuit.....	2
	182-525	SCREW - #10 - 32 x 3/8" (2 circuit switch mount).....	1
	182-528	SCREW - #10 - 32 x 1/2" (2 circuit switch mount).....	1
	192-18	LOCKWASHER - #10 (2 circuit switch mount).....	2
	193-1000	NUT - #10 - 32 lock (2 circuit switch mount).....	2
7	C43044	SWITCH - light.....	1
8	C32178	HEADLIGHT - <a href="#">(see page 61)</a> .....	2
9	C43610	ALTERNATOR - <a href="#">repairs page 55</a> .....	1
10	C31947	KIT - fuse holder.....	1
10	C30260	FUSE - 30 amp.....	1
11	C43609	STARTER - <a href="#">repair page 53</a> .....	1
12	P185206082	SOLENOID - fuel shut off.....	1
13	C44169	CONNECTOR - headlight terminal.....	2
14	C31937	SWITCH - PTO.....	1
	C31620	NUT - 1/2" - 27 black (PTO switch mount).....	1
	C31619	CAP - PTO switch.....	1
15	C44012	SWITCH - seat (N.O.).....	1
16	C44071	BATTERY - 12 volt, 450 CCA (see page 61).....	1
17	C43602	SENDER - temperature, water.....	1
18	C37511	CLUTCH - PTO, electric.....	1
19	C37505	BREAKER - circuit, 10 amp.....	1
20	C42929	HOURLY METER.....	1
21	C29413	AMMETER.....	1
22	C45363	GAGE - temperatures.....	1
	C45364	TERMINAL - temperature gage.....	1
	C44169	CONNECTOR - temperature gage.....	1
	C31977	CLAMP - temperature tube.....	1
23	C42829	SWITCH - ignition.....	1
23	C42855	KEY - ignition.....	1
24	C42830	INDICATOR - glow plug.....	1
25	C42831	REGULATOR - voltage.....	1
	113-17	BOLT - 1/4" - 20 x 1-1/4" (regulator mount).....	2
	192-19	LOCKWASHER - 1/4" (regulator mount).....	2
	129-101	NUT - 1/4" - 20 (regulator mount).....	2
26	C43603	HEATER - glow plug.....	3



**WARNING**

READ OPERATOR'S MANUALS.  
KNOW LOCATION & FUNCTION OF ALL CONTROLS.  
KEEP ALL GUARDS, SHIELDS & SAFETY SWITCHES IN PLACE & WORKING.  
CLEAN WORK AREA OF THINGS THAT COULD BE THROWN BY THE BLADES.  
DO NOT SHOW WHEN CHILDREN OR OTHERS ARE AROUND.  
NEVER CARRY CHILDREN.  
LOOK DOWN & BEHIND BEFORE AND WHILE BACKING.  
GO UP AND DOWN SLOPES, NOT ACROSS.  
IF MACHINE STOPS GOING UPHILL, STOP BLADES AND BACK DOWN SLOWLY.  
AVOID SLIDING TURNS.  
FAILURE TO OBSERVE THESE PRECAUTIONS COULD RESULT IN SERIOUS INJURY OR DEATH.

21

13

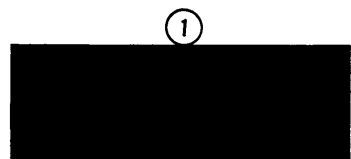
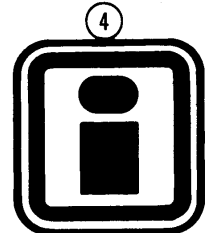

10

**OPERATION OF CONTROLS**

**CAUTION!** READ OPERATING MANUAL BEFORE OPERATING THIS MACHINE.

CONTROL THE SPEED THROUGH THE USE OF TRANSMISSION CONTROL ONLY.

• FORWARD •	•
• NEUTRAL •	•
• REVERSE •	•

12

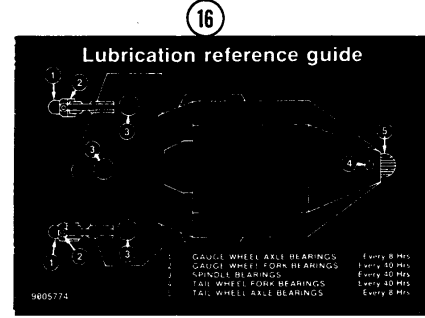
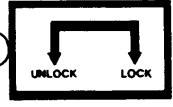

11

**CAUTION**

THIS MACHINE HAS AN IGNITION INTER-LOCK SAFETY SYSTEM. ALL CONTROLS MUST BE IN NEUTRAL BEFORE THE ENGINE WILL START.

17

**HYDRAULIC OIL**

23

**CAUTION**

WHEN THE VACUUM BLOWER IS REMOVED FROM THE MOWER DECK, REPLACE IT WITH THE DISCHARGE CHUTE.

14

**CAUTION**

WHEN MOVING OR TRANSPORTING KEEP HYDRAULIC VALVE IN FLOAT POSITION.

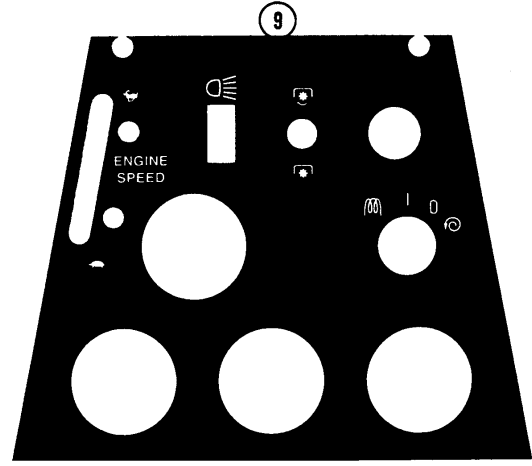

22

**CAUTION**

**WHIRLING BLADES**

KEEP HANDS AND FEET CLEAR

24

**CAUTION**

DO NOT OPERATE THIS MACHINE WITHOUT ENTIRE GRASS CHUTE OR VACUUM ASSEMBLY FURNISHED BY THE MANUFACTURER.

25

DO NOT OPERATE MOWER UNLESS THIS GUARD OR ENTIRE GRASS-CATCHER IS IN ITS PROPER PLACE.

**DANGER**

KEEP HANDS and FEET AWAY

8

*Diesel*

18

**DIESEL FUEL ONLY**

20

**CAUTION**

DO NOT USE ETHER OR STARTING FLUID. SEVERE ENGINE DAMAGE WILL OCCUR.

19

**CAUTION**

A SOLUTION OF 50% ANTI-FREEZE AND 50% WATER MUST BE USED IN THIS ENGINE. (FREEZING POINT ABOUT -34°F). DO NOT USE 100% ANTI-FREEZE. OR SEVERE DAMAGE WILL OCCUR.

15

**DANGER**

ENGINES PRODUCE CARBON MONOXIDE WHICH IS AN ODORLESS DEADLY POISON. DO NOT OPERATE IN AN ENCLOSED AREA.

**INDEX**

**DECALS**

<b>REF.</b>	<b>PART NO.</b>	<b>DESCRIPTION</b>	<b>REQ'D</b>
1	C44589	DECAL - front.....	1
2	C45466	DECAL - side, rear.....	2
3	C43947	DECAL - logo L.H.....	1
3	C43948	DECAL - logo R.H.....	1
4	C37464	MEDALLION - "Ingersoll".....	1
6	C43970	DECAL - rear R.H. (not shown).....	1
6	C43971	DECAL - rear L.H. (not shown).....	1
8	C43410	DECAL - "Diesel".....	3
9	C45163	DECAL - instrument panel.....	1
10	C37495	DECAL - operation.....	1
11	C37496	DECAL - "CAUTION" interlock.....	1
12	C37502	DECAL - unlock/lock.....	1
13	C37498	DECAL - run/park.....	1
14	C37503	DECAL - "CAUTION" hydraulic lift.....	1
15	C37500	DECAL - "DANGER" carbon monoxide.....	1
16	C38807	DECAL - lubrication.....	1
17	C37499	DECAL - hydraulic oil.....	1
18	C37497	DECAL - diesel fuel only.....	2
19	C43091	DECAL - anti-freeze.....	1
20	C43092	DECAL - ether.....	1
21	C44340	DECAL - "WARNING".....	1
22	C37491	DECAL - "WHIRLING BLADES".....	1
23	C37492	DECAL - "CAUTION" discharge.....	1
24	C37493	DECAL - "CAUTION" grass chute.....	1
25	C37494	DECAL - "DANGER".....	1

**INDEX**

**MOWER DECK AND ATTACHING PARTS (52")**

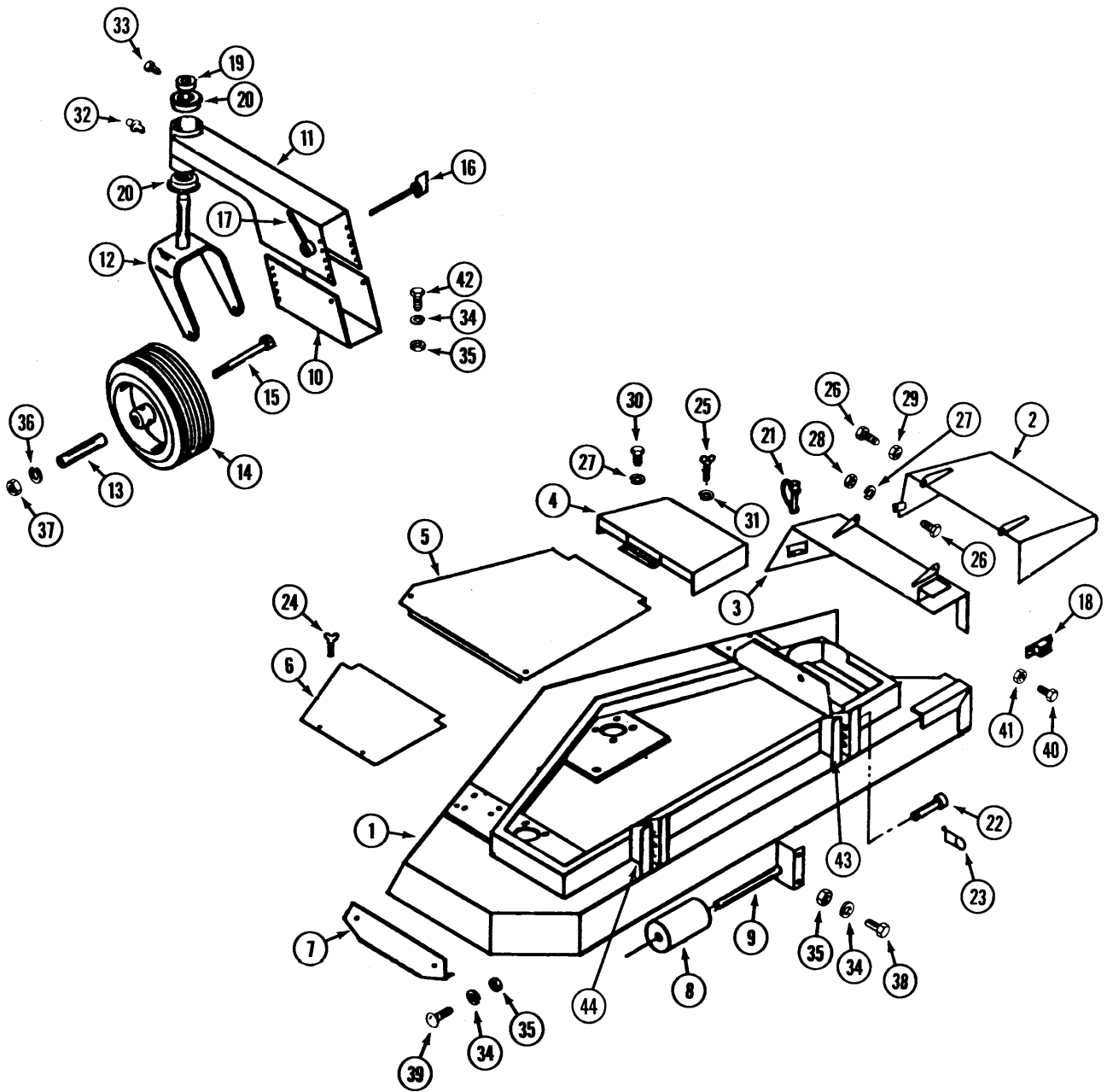



**INDEX**

**52" MOWER DECK AND ATTACHING PARTS**

REF.	PART NO.	DESCRIPTION	REQ'D
1	C44086	DECK - 52" .....	1
2	C39208	CHUTE - foot guard .....	1
3	C39209	MOUNT - foot guard.....	1
4	C39204	COVER - pulley.....	1
5	C39203	COVER - center .....	1
6	C39200	COVER - L.H.....	1
7	C37942	SHOE - skid .....	1
8	C37910	ROLLER - anti-scalp .....	1
9	C37911	SHAFT - roller .....	1
10	C37912	BRACKET - gauge wheel mount .....	2
11	C37913	MOUNT - gauge wheel .....	2
12	C37914	FORK .....	2
13	C37915	AXLE - wheel .....	2
14	C37916	WHEEL - gauge .....	2
	C37917	TIRE - 11 x 4.00 - 5 .....	1
	C37918	RIM - 5" .....	1
	C44499	BEARING - wheel.....	2
15	113-2419	BOLT - 1/2" - 13 x 6-1/2" .....	2
16	C37920	BOLT - wing .....	4
17	C37921	NUT - gauge wheel handle .....	4
18	C37505	BREAKER - circuit, 10 amp .....	1
19	C37860	COLLAR - set.....	2
20	C37824	BEARING - 1".....	4
21	C37922	PIN - "fas-tatch" .....	1
22	C10821	PIN - deck.....	1
23	C29029	PIN - cotter, hair .....	2
24	NSS	SCREW - thumb 1/4" - 20 x 1/2" (use 113-3 and 192-19) .....	4
25	NSS	SCREW - wing 1/4" -20 x 1" (use 113-3) .....	1
26	113-3	BOLT - 1/4" - 20 x 3/4" .....	4
27	192-19	LOCKWASHER - 1/4" .....	2
28	129-101	NUT - 1/4" -20 .....	2
29	131-71	NUT - 1/4" - 20 lock.....	2
30	113-1	BOLT - 1/4" - 20 x 1" .....	2
31	195-102	WASHER - 1/4" .....	1
32	C37993	FITTING - grease .....	2
33	C37756	SCREW - set 5/16" - 18 x 1/2" square head .....	2
34	192-20	LOCKWASHER - 5/16" .....	6
35	129-102	NUT - 5/16" - 18 .....	6
36	192-23	LOCKWASHER - 1/2" .....	2
37	129-105	NUT- 1/2" -13 .....	2
38	113-102	BOLT - 5/16" - 18 x 3/4" .....	2
39	111-202	BOLT - 5/16" - 18 x 3/4" carriage .....	2
40	182-528	SCREW - #10 - 32 x 1/2" .....	2
41	C37598	NUT - #10-32 .....	2
42	111-203	BOLT - 5/16" - 18 x 1" carriage .....	6

52" MOWER DRIVE

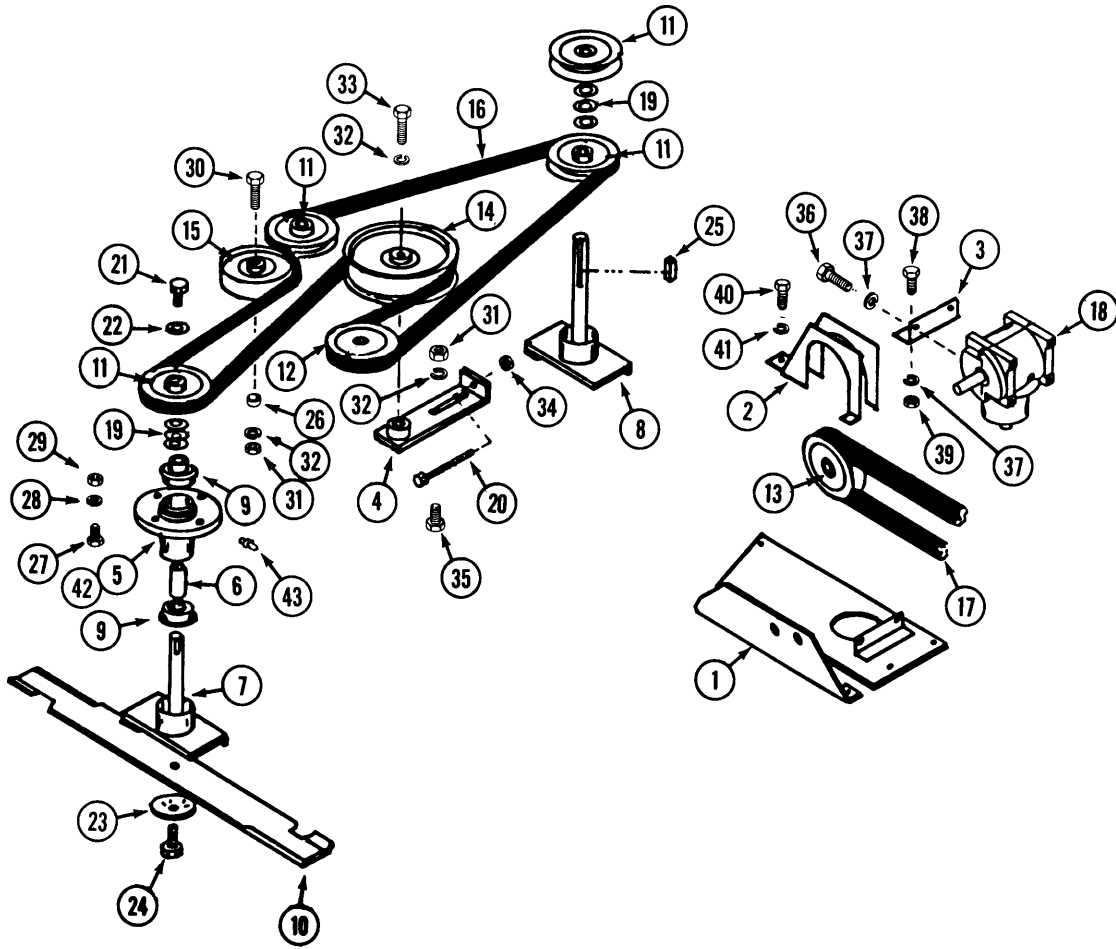

REF.	PART NO.	DESCRIPTION	REQ'D
1	C39205	MOUNT - gear box.....	1
2	C37875	GUARD - belt.....	1
3	C37877	ANGLE - gear box mount.....	1
4	C37929	TIGHTENER - belt.....	1
5	C37880	HOUSING - spindle.....	3
6	C37881	SPACER - spindle.....	3
7	C37883 *	SHAFT - spindle, short.....	2
7	C44128 **	SHAFT - spindle, short.....	1
8	C37884 *	SHAFT - spindle, long.....	1
8	C44130 **	SHAFT - spindle, long.....	1
9	C42786 *	BEARING - spindle.....	3
10	C37930	BLADE - mower.....	3
10	C44136 **	BLADE - mower.....	1
11	C37931	PULLEY - spindle.....	4
12	C37932	PULLEY - gear box output.....	1
13	C37893	PULLEY - gear box input.....	1
14	C37933	PULLEY - idler, large.....	1
15	C37934	PULLEY - idler, small.....	1
16	C37935	BELT - deck.....	1
17	C37895	BELT - drive.....	2
18	C37898	GEAR BOX - angle drive (see page 83 for repairs) (Curtis model).....	1
18	C42775	GEAR BOX - angle drive (see page 83 for repairs) (Superior model).....	1
19	C37888	SPACER - washer.....	12
20	C37901	BOLT - 1/4" - 20 x 4".....	1
21	C39386	BOLT - 5/16" - 24 x 3/4" lock.....	3
22	C37900	WASHER - 5/16" - 10 gage.....	3
23	C37886 *	WASHER - blade.....	3
24	C37557 *	BOLT - 3/8" - 24 x 1-1/4".....	3
24	113-268 **	BOLT - 3/8" - 16 x 1" (also required 131-1216 locknut).....	6
25	C29581	KEY - 3/16" x 1".....	6
26	C37937	SPACER - idler pulley.....	1
27	113-312	BOLT - 7/16" - 14 x 1-1/4".....	12
28	192-22	LOCKWASHER - 7/16".....	12
29	129-104	NUT - 7/16" - 14.....	12
30	113-257	BOLT - 3/8" - 16 x 2-1/2".....	1
31	129-103	NUT - 3/8".....	1
32	192-21	LOCKWASHER - 3/8".....	1
33	113-208	BOLT - 3/8" - 16 x 1-1/4".....	1
34	131-71	NUT - 1/4" - 20 lock.....	1
35	111-371	BOLT - 3/8" - 16 x 1" carriage.....	1
36	113-103	BOLT - 5/16" - 18 x 1".....	4
37	192-20	LOCKWASHER - 5/16".....	5
38	113-102	BOLT - 5/16" - 18 x 3/4".....	1
39	129-102	NUT - 5/16" - 18.....	1
40	113-1	BOLT - 1/4" - 20 x 1/2".....	2
41	192-19	LOCKWASHER - 1/4".....	2
42	C37902	HOUSING ASSEMBLY - spindle (includes ref. 5, 6, 9).....	3
43	219-20	FITTING - grease 1/4" - 28.....	3

\* Use before S/N: 013306046

\*\* Use S/N: 013306046 and after

**INDEX**

**62" MOWER DECK AND ATTACHING PARTS**

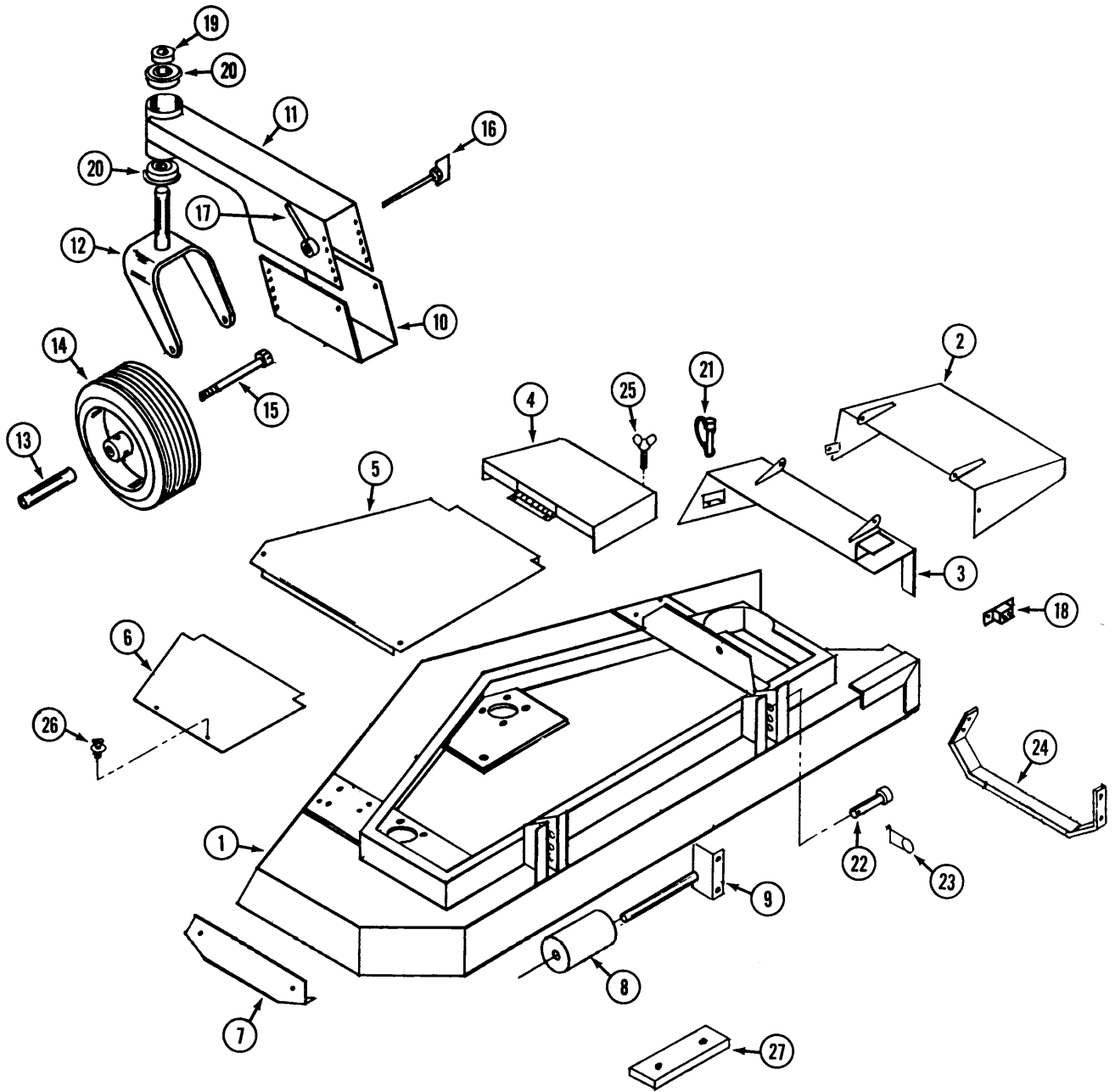

**INDEX**

**62" MOWER DECK AND ATTACHING PARTS**

REF.	PART NO.	DESCRIPTION	REQ'D
1	C44088	DECK - 62" .....	1
2	C41396	CHUTE - foot guard .....	1
3	C41400	MOUNT - foot guard.....	1
4	C41392	COVER - pulley.....	1
5	C41378	COVER - center .....	1
6	C41373	COVER - L.H.....	1
7	C37956	SHOE - skid L.H.....	1
8	C37910	ROLLER - anti-skid .....	1
9	C37911	SHAFT - roller .....	1
10	C37912	BRACKET - gauge wheel mount .....	2
11	C37913	MOUNT - gauge wheel .....	2
12	C37914	FORK - gauge wheel.....	2
13	C37915	AXLE - gauge wheel .....	2
14	C37916	WHEEL - gauge .....	2
	C37917	TIRE - 11 x 4.00-5 .....	1
	C37918	RIM - 5 .....	1
	C44499	BEARING - wheel.....	2
15	113-2419	BOLT - 1/2" - 13 x 6-1/2" .....	2
16	C37920	BOLT-wing .....	4
17	C37921	NUT - gauge wheel handle .....	4
18	C37505	BREAKER - circuit - 10 amp .....	1
19	C37860	COLLAR - set 1".....	2
20	C37824	BEARING - 1".....	4
21	C37922	PIN - "fas-tatch" .....	1
22	C10821	PIN - deck.....	2
23	C29029	PIN - cotter, hair .....	2
24	C37957	SHOE - skid R.H .....	1
25	NSS	SCREW - thumb 1/4" -20 x 1/2" (use 113-3 and 192-19).....	4
26	NSS	SCREW - wing 1/4" - 20 x 1" (use 113-3) .....	1
27	C37958	WEIGHT - tail, 13 lb .....	3

62" MOWER DRIVE

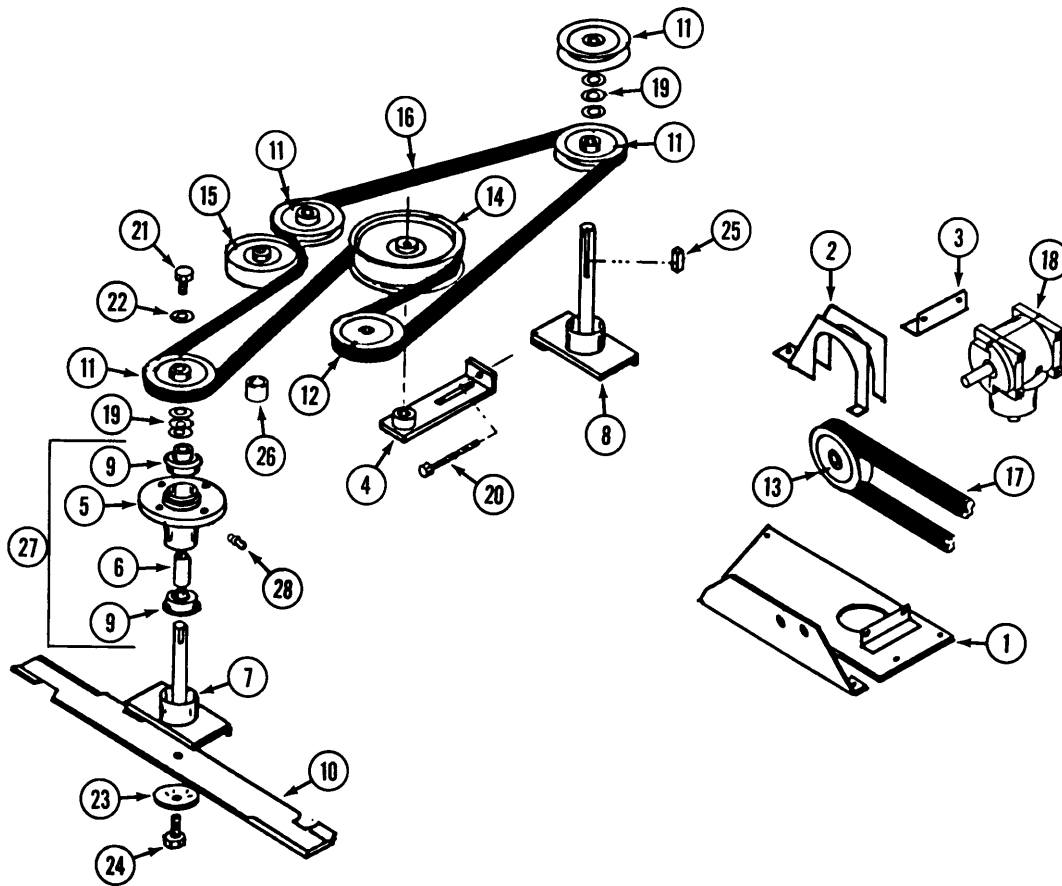

**INDEX**

**62" MOWER DRIVE**

REF.	PART NO.	DESCRIPTION	REQ'D
1	C41757	MOUNT - gearbox.....	1
2	C37876	GUARD - belt.....	1
3	C37877	ANGLE - gear box mount.....	1
4	C37929	TIGHTENER - belt.....	1
5	C37945	HOUSING - spindle.....	3
6	C37946	SPACER - spindle.....	3
7	C37947 *	SHAFT - spindle, short.....	2
7	C44132 **	SHAFT - spindle, short.....	2
8	C37948 *	SHAFT - spindle, long.....	1
8	C44134 **	SHAFT - spindle, long.....	1
9	C42786	BEARING - spindle.....	6
10	C37949 *	BLADE.....	3
10	C44138 **	BLADE.....	3
11	C37950	PULLEY - spindle.....	4
12	C37932	PULLEY - gear box output.....	1
13	C37893	PULLEY - gear box input.....	1
14	C37933	PULLEY - idler, large.....	1
15	C37934	PULLEY - idler, small.....	1
16	C38929	BELT - deck.....	1
17	C38566	BELT - drive.....	2
18	C37898	GEAR BOX - angle drive (see page 83 for service) (Curtis model).....	1
18	C42775	GEAR BOX - angle drive (see page 83 for service) (Superior model).....	1
19	C37888	WASHER - spacer.....	12
20	C37901	BOLT - 1/4" - 20 x 4".....	1
21	C39386	BOLT - 5/16" - 24 x 3/4".....	3
22	C37900	WASHER - 5/16", 10 gage.....	3
23	C37886 *	WASHER - blade.....	3
24	C37557 *	BOLT - 3/8" - 24 x 1-1/4".....	3
24	113-268 **	BOLT - 3/8" - 16 x 1" (also requires 131-1216 locknut).....	6
25	C29581	KEY - 3/16" x 3/16" x 1".....	6
26	C37937	SPACER - idler pulley.....	1
27	C37951	HOUSING ASSEMBLY - spindle (includes ref. 5, 6, 9).....	3
28	219-20	FITTING - grease 1/4" - 28.....	3

For model 62TCSS  
 \* Use before S/N 013306063  
 \*\* Use S/N 013306063 and after

For model 62TCII  
 \* Use before S/N 013307056  
 \*\* Use S/N 013307056 and after

INDEX

### GEAR BOX (Curtis)

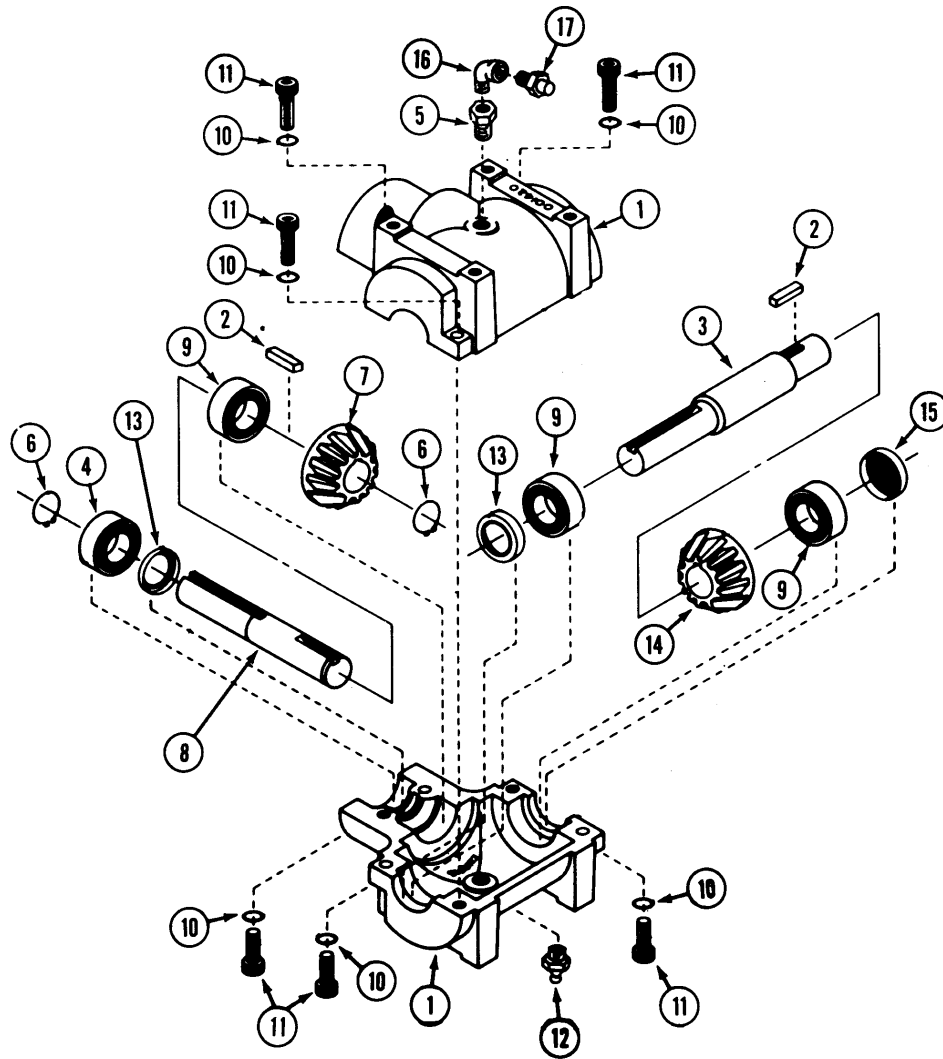

INDEX

### GEAR BOX (Superior)

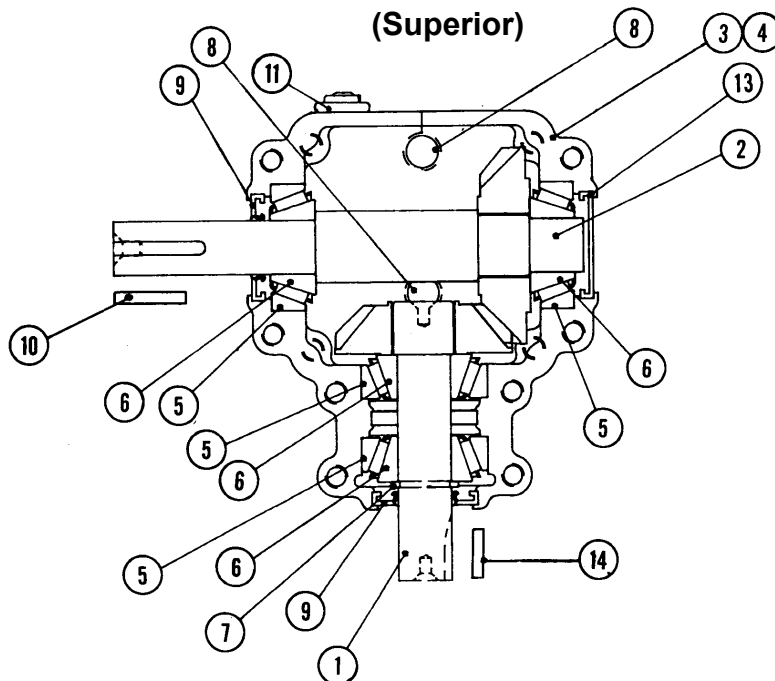



**INDEX****GEAR BOX  
(Curtis)**

REF.	PART NO.	DESCRIPTION	REQ'D
	C44917	GEARBOX.....	1
1	C37959	HOUSING - half.....	2
2	C29581	KEY - 3/16" x 3/16" x 1".....	2
3	C37960	SHAFT - input.....	1
4	C37961	BEARING - ball.....	1
5	221-84	BUSHING - pipe 1/4" x 1/8".....	1
6	C37963	RING - retaining.....	2
7	C37964	GEAR - output shaft.....	1
8	C37965	SHAFT - output.....	1
9	C37966	BEARING - ball.....	3
10	C37967	LOCKWASHER.....	6
11	C37968	CAP SCREW - allen head.....	6
12	219-23	FITTING - grease 1/4" NPT.....	1
13	C37969	SEAL - shaft.....	2
14	C37970	GEAR - input shaft.....	1
15	C37971	PLUG - expansion.....	1
16	221-441	ELBOW - Street 1/8" x 900.....	1
17	C28241	VALVE - relief.....	1
	C37975	GREASE - synthetic, cartridge.....	1

**INDEX****GEAR BOX  
(Superior)**

	NSS	GEAR BOX - (use C44917 for service).....	1
1	C42924	SHAFT - pinion, with gear.....	1
2	C42923	SHAFT - cross, with gear.....	1
3	C42917	HOUSING - with tapped holes.....	1
4	C42927	HOUSING with thru holes (not shown).....	1
5	C42918	CUP - bearing.....	4
6	C42921	CONE - bearing.....	4
7	C42919	RING - retaining.....	1
8	C42920	PLUG - pipe 1/4".....	3
9	C42922	SEAL - shaft.....	2
10	C29581	KEY - 3/16" x 1" input shaft.....	1
11	C42928	PIPE - vent.....	1
12	C42926	BOLT - 5/16" x 1" socket head (not shown).....	8
13	C42925	CAP - end.....	1
14	C28215	KEY - 3/16" x 5/8" output shaft.....	1