



Ingersoll

HOME

TRACTORS

**Ameriquip Backhoe
Model 80A
Parts Listing**

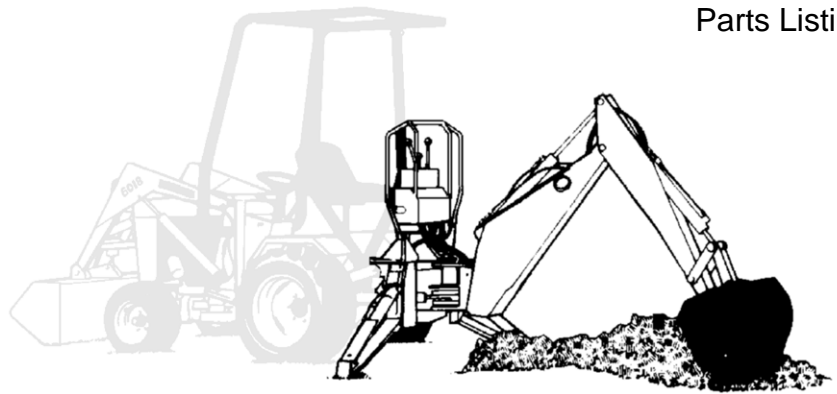

INDEX

Control Valve Section – Lift Circuit	22-23
Control Valve Section – Crowd Circuit.....	24-25
Control Valve Section – Bucket, Swing and Stabilizer	26-27
Main Relief	28
Valve Assembly, Shroud, Cover Plate and Handles	29
Boom, Dipperstick, Bucket and Cylinders.....	30-31
Swing Cylinders and Frame Assembly	32
Stabilizer, Mainframe and Stabilizer Cylinders	33
Hoses – Bucket Dipperstick and Boom	34
Hoses – Stabilizer and Swing	35
Cylinder Kits and Parts	36-37

CONTROL VALVE SECTION
TYPICAL SECTION FOR LIFT CIRCUIT

FIG 10

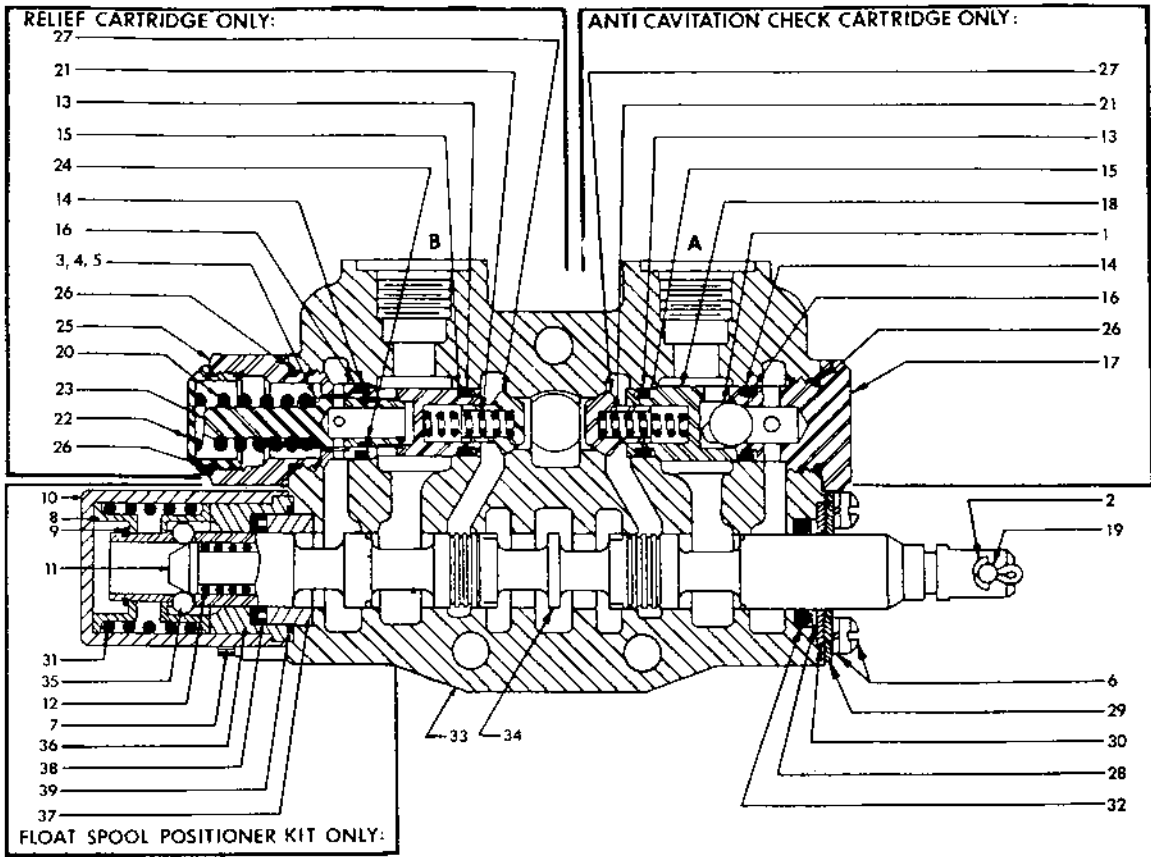

**Model 80A
Control Valve Section – Lift Circuit**

Index	Part No.	Description	Qty. Per Section
1	*	7/16" Steel Ball.....	1
2	132-320	Handle Pin Cotter, 3/32 x 3/4.....	1
3,4,5	*	Shim, (.010", .020", .040" thick).....	as required
6	*	Machine Screw and Lockwasher.....	2
7	***	Bonnet Screw.....	2
8	***	Stop Collar.....	2
9	***	Retaining Ring.....	1
10	***	Bonnet.....	1
11	***	Detent Ball Follower.....	1
12	***	Detent spring.....	1
13	**	O-Ring Seal (Inner).....	2
14	**	O-Ring Seal (Outer).....	2
15	**	Back-Up Washer (Inner).....	4
16	**	Back-Up Washer (Outer).....	2
17	*	Anti-Cavitation Check Body.....	1
18	*	Check Ball Retainer.....	1
19	C42678	Handle Clevis Pin, 1/4 dia. x 7/8.....	1
20	*	Spring (2201 - 3000 PSI Crack).....	1
21	*	Check Spring.....	2
22	*	Relief Cap.....	1
23	**	Relief Poppet.....	1
24	**	Piston Ring.....	1
25	*	Relief Body.....	1
26	**	O-Ring Seal.....	3
27	*	Steel Check.....	2
28	**	Back-Up Washer.....	2
29	C42665	Seal Plate Retainer.....	1
30	C42666	Seal Retainer.....	2
31	***	Centering Spring.....	1
32	**	Spool O-Ring Seal.....	2
33	*	Center Section Housing.....	1
34	*	Four-Way Spool.....	1
35	***	Detent Ball.....	4
36	***	Float Sleeve.....	1
37	***	Retaining Sleeve.....	1
38	**	U-Cup Seal.....	1
39	**	O-Ring Seal.....	1
	C42670	Control Valve Section - Lift Circuit, consisting of above listed parts. NOTE - one orifice plate C42657 must be added to "A" port to complete lift section. Also, one heavy duty seal plate retainer kit C42885 (not shown) must be added and bolted over seal plate retainer (29) to complete lift section.....	1
	C42667	Control Valve Section Seal Kit - Lift Circuit, consisting of: 32 (Qty 1), 13 (Qty 2), 14 (Qty 2), 28 (Qty 1), 38 (Qty 1), 39 (Qty 1), 15 (Qty 4), 16 (Qty 2), 26 (Qty 2), pressure section seal (Qty 2), and exhaust section seal (Qty 2).....	1
	C42668	Spool Seal Kit; consisting of: 32 (Qty 1), 28 (Qty 1), 38 (Qty 1), and 39 (Qty 1).....	1
	C42658	Relief Cartridge (2500 PSI), as shown.....	1
	C42662	Relief Cartridge Seal Kit; consisting of: 13 (Qty 1), 14 (Qty 1), 15 (Qty 2), 16 (Qty 1), 26 (Qty 2)...	1
	C42656	Poppet Seal Kit, consisting of: 23 (Qty 1) and 24 (Qty 1)...	1
	C42659	Anti-Cavitation Check Cartridge, as shown.....	1
	C42662	Anti-Cavitation Check Seal Kit, same as Relief Cartridge Seal Kit listed above.....	1
	C42669	Float Spool Positioner Kit, as shown.....	1
	*	Not available as a separate repair part, order complete section or cartridge.	
	**	Not available as a separate repair part, order seal kit.	
	***	Not available as a separate repair part, order spool positioner kit.	

CONTROL VALVE SECTION TYPICAL SECTION FOR CROWD CIRCUIT

FIG 11

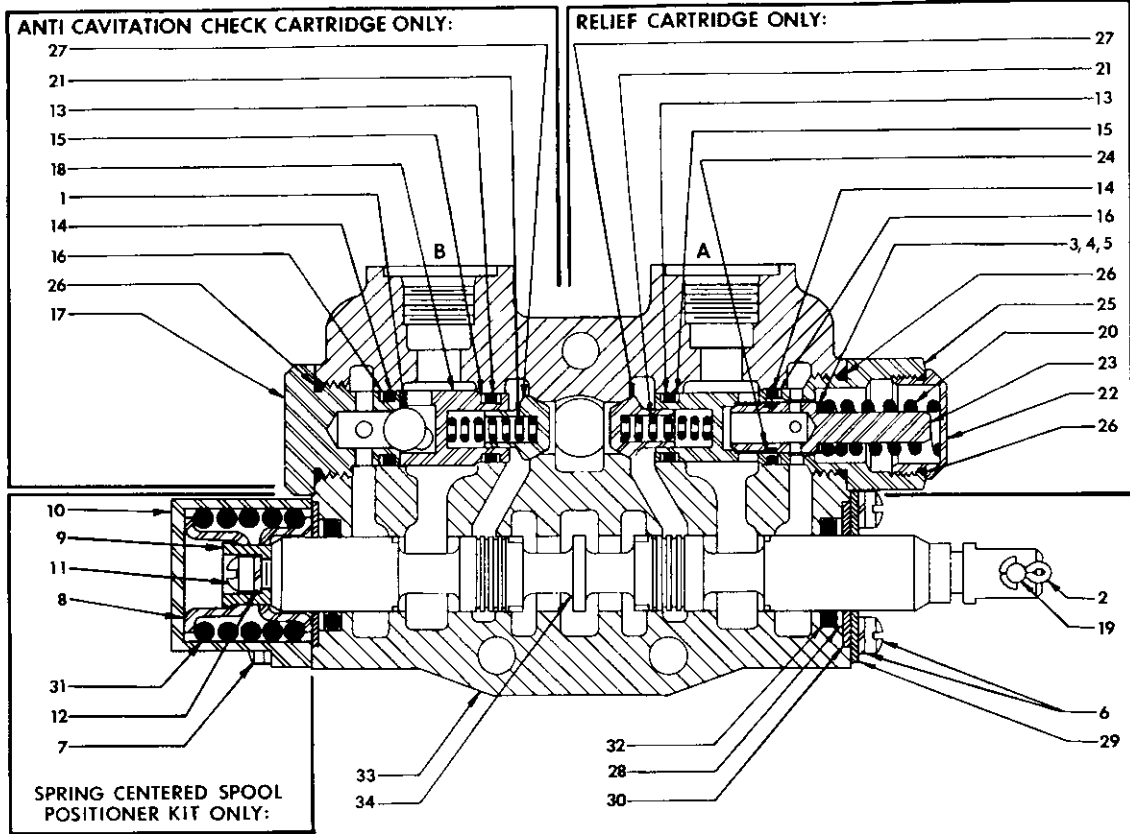

**Model 80A
Control Valve Section – Crowd Circuit**

Index No.	Part No.	Description	Quantity Per Section
1	*	7/16" Steel Ball.....	1
2	132-320	Handle Pin Cotter, 3/32 x 3/4.....	1
3	*	Shim, .040" Thick)	
4	*	Shim, .020" Thick).....	as required
5	*	Shim, .010" Thick)	
6	*	Machine Screw and Lockwasher.....	2
7	***	Bonnet Screw.....	2
8	***	Stop Collar.....	2
9	***	Spool Collar.....	1
10	***	Bonnet.....	1
11	***	Spool Assembly Screw.....	1
12	***	Spool Assembly Screw Lockwasher.....	1
13	**	O-Ring Seal (Inner).....	2
14	**	O-Ring Seal (Outer).....	2
15	**	Back-Up Washer (Inner).....	4
16	**	Back-Up Washer (Outer).....	2
17	*	Anti-Cavitation Check Body.....	1
18	*	Check Ball Retainer.....	1
19	C42678	Handle Clevis Pin, 1/4 Dia x 7/8.....	1
20	*	Spring (2201 - 3000 PSI Crack).....	1
21	*	Check Spring.....	2
22	*	Relief Cap.....	1
23	**	Relief Poppet.....	1
24	**	Piston Ring.....	1
25	*	Relief Body.....	1
26	**	O-Ring Seal.....	3
27	*	Steel Check.....	2
28	**	Back-Up Washer.....	2
29	C42665	Seal Plate Retainer.....	1
30	C42666	Seal Retainer.....	2
31	***	Centering Spring.....	1
32	**	Spool O-Ring Seal.....	2
33	*	Center Section Housing.....	1
34	*	Four-Way Spool.....	1
	C42650	Control Valve Section - Crowd Circuit, consisting of above listed parts. NOTE - one heavy duty seal plate retainer kit C42885 (not shown) must be added and bolted over seal plate retainer (29) to complete crowd section.....	1
	C42663	Control Valve Section Seal Kit - Crowd Circuit, consisting of: 32(quan-2), 13(quan-2), 14(quan-2), 15(quan-4), 16(quan-2), 26(quan-2), pressure section seal(quan-2), and exhaust section seal(quan-2).....	1
	C42664	Spool Seal Kit; consisting of: 32(quan-2) and 28(quan-2).....	1
	C42658	Relief Cartridge (2500 PSI), as shown.....	1
	C42662	Relief Cartridge Seal Kit; consisting of: 13(quan-1), 14(quan-1), 15(quan-2), 16(quan-1), and 26(quan-2).....	1
	C42656	Poppet Seal Kit, consisting of: 23(quan-1) and 24(quan-1).....	1
	C42659	Anti-Cavitation Check Cartridge, as shown.....	1
	C42662	Anti-Cavitation Check Seal Kit, same as Relief Cartridge Seal Kit listed above.....	1
	C42648	Spring Centered Spool Positioner Kit, as shown.....	1

* Not available as a separate repair part, order complete section or cartridge.
 ** Not available as a separate repair part, order seal kit.
 *** Not available as a separate repair part, order spool positioner kit.

CONTROL VALVE SECTION

TYPICAL SECTION FOR ACTUATE (BUCKET), SWING, AND STABILIZER CIRCUITS

FIG 12

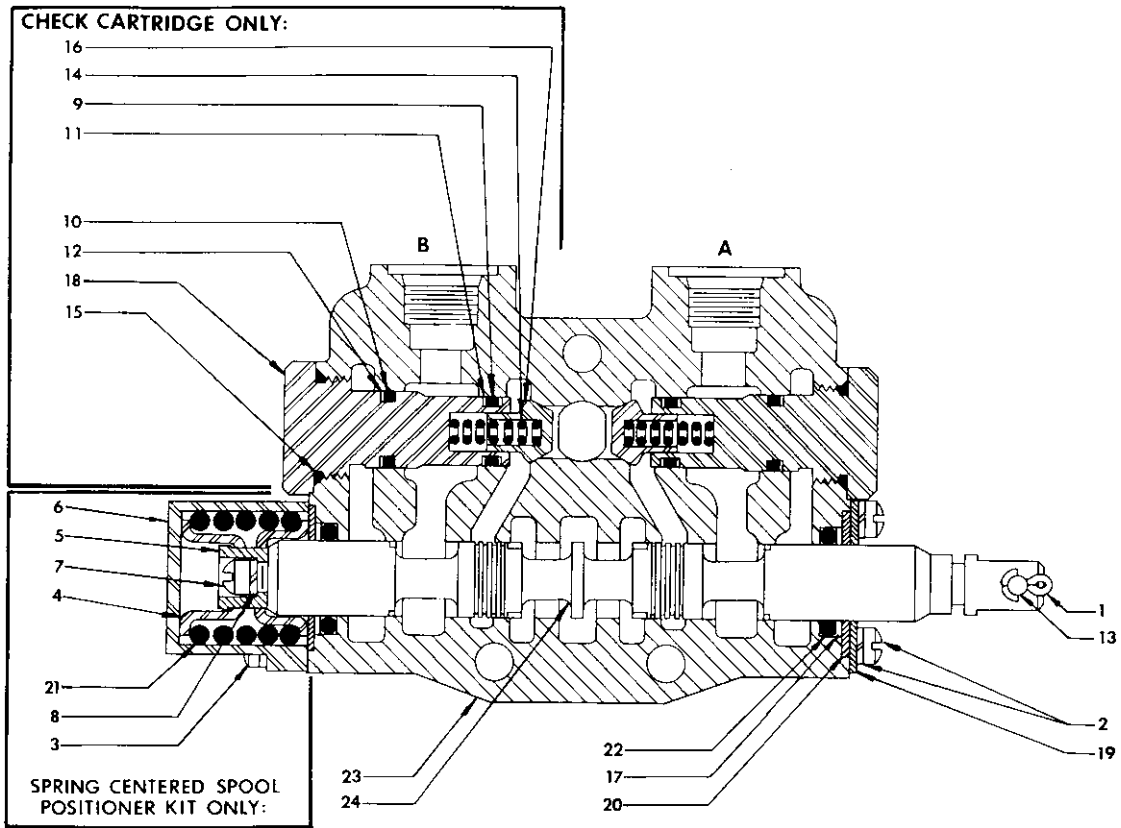

Model 80A

CONTROL VALVE SECTION - ACTUATE (BUCKET), SWING, AND STABILIZER CIRCUITS

PARTS LIST - FIG 12

Index No.	Part No.	Description	Quantity Per Section
1	132-320	Handle Pin Cotter, 3/32 x 3/4.....	1
2	*	Machine Screw and Lockwasher.....	2
3	***	Bonnet Screw.....	2
4	***	Stop Collar.....	2
5	***	Spool Collar.....	1
6	***	Bonnet.....	1
7	***	Spool Assembly Screw.....	1
8	***	Spool Assembly Screw Lockwasher.....	1
9	**	Check Plug O-Ring Seal (Inner).....	2
10	**	Check Plug O-Ring Seal (Outer).....	2
11	**	Back-Up Washer (Inner).....	4
12	**	Back-Up Washer (Outer).....	2
13	C42678	Handle Clevis Pin, 1/4 Dia x 7/8.....	1
14	*	Lift Check Spring.....	2
15	**	Lift Check Plug O-Ring Seal.....	2
16	*	Lift Check Poppet.....	2
17	**	Back-Up Washer.....	2
18	*	Lift Check Plug.....	2
19	C42665	Seal Plate Retainer.....	1
20	C42666	Seal Retainer.....	2
21	***	Centering Spring.....	1
22	**	Spool O-Ring Seal.....	2
23	*	Center Section Housing.....	1
24	*	Four-Way Spool.....	1
	C42651	Control Valve Section - Actuate (Bucket), Swing, and Stabilizer Circuits, consisting of above listed parts.....	1
		NOTE - Two Orifice Plates C42657 must be added to complete Swing Section. Also, one heavy duty seal plate retainer kit C42885 (not shown) must be added and bolted over seal plate retainer (19) to complete bucket or swing sections (not required on stabilizer section).	
	C42663	Control Valve Section Seal Kit - Actuate (Bucket), Swing, and Stabilizer Circuits, consisting of: 22(quan-2), 9(quan-2), 10(quan-2), 11(quan-4), 12(quan-2), 15(quan-2), pressure section seal (quan-2), and exhaust section seal(quan-2).....	1
	C42664	Spool Seal Kit; consisting of: 22(quan-2) and 17 (quan-2).....	1
	C42660	Check Cartridge, as shown.....	2
	C42662	Check Cartridge Seal Kit; consisting of: 9(quan-1), 10(quan-1), 11(quan-2), 12(quan-1), and 15(quan-2).....	2
	C42648	Spring Centered Spool Positioner Kit, as shown.....	1

* Not available as a separate repair part, order complete section or cartridge.
 ** Not available as a separate repair part, order seal kit.
 *** Not available as a separate repair part, order spool positioner kit.

MAIN SYSTEM RELIEF VALVE (1950 PSI)

LOCATION: LEFT HAND VALVE COVER

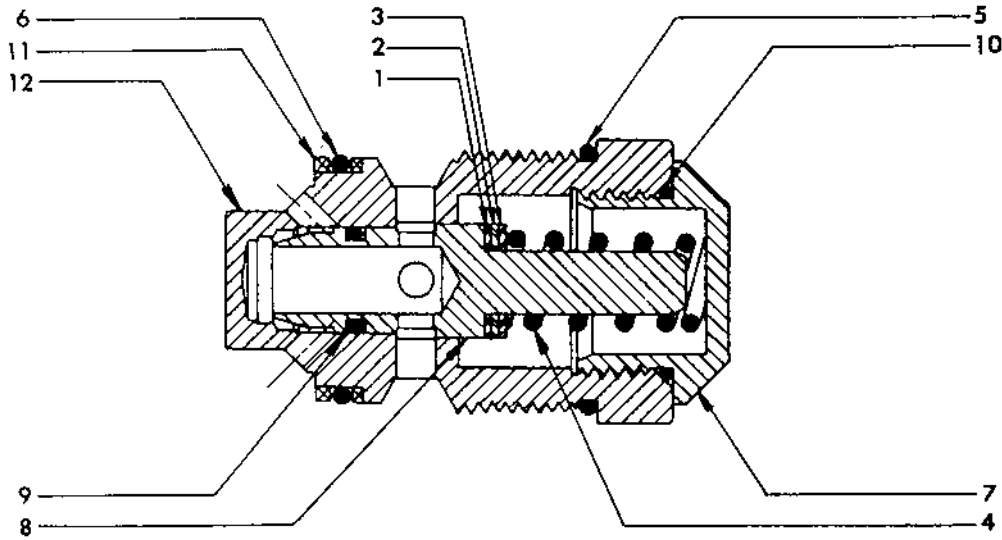

FIG 13

MAIN SYSTEM RELIEF VALVE

PARTS LIST - FIG 13

Index No.	Part No.	Description	Required
1	*	Shim, .040" Thick)	
2	*	Shim, .020" Thick).....	as required
3	*	Shim, .010" Thick)	
4	*	Spring (1751 - 2200 PSI Crack).....	1
5	**	O-Ring Seal.....	1
6	**	O-Ring Seal.....	1
7	*	Relief Cap.....	1
8	**	Relief Poppet.....	1
9	**	Piston Ring.....	1
10	**	O-Ring Seal.....	1
11	**	Back-Up Washer.....	2
12	*	Body.....	1
	C42694	Main System Relief Valve, consisting of above listed parts.....	1
	C42654	Seal and Service Kit; consisting of: 5(quan-1), 6(quan-1), 8(quan-1), 9(quan-1), 10(quan-1), and 11(quan-2).....	1

* Not available as a separate repair part, order complete Main System Relief Valve.

** Not available as a separate repair part, order Seal and Service Kit.

ADDITIONAL REPAIR PARTS (NOT SHOWN)

Part No.	Description	Required
C42695	Left Hand End Cover with Main Relief Valve.....	1
C42652	Tie Rod Kit (Six-Spool) contains three Studs and three Stud Nuts.....	1
C42655	Valve Seal Kit, containing all O-Rings and Back-Up Rings for a Six-Spool Valve.....	1
C42693	Six-Spool Valve.....	1
C42661	Right Hand End Cover.....	1
C42696	Section Seal Kit, contains all o-rings between sections.....	1

INDEX

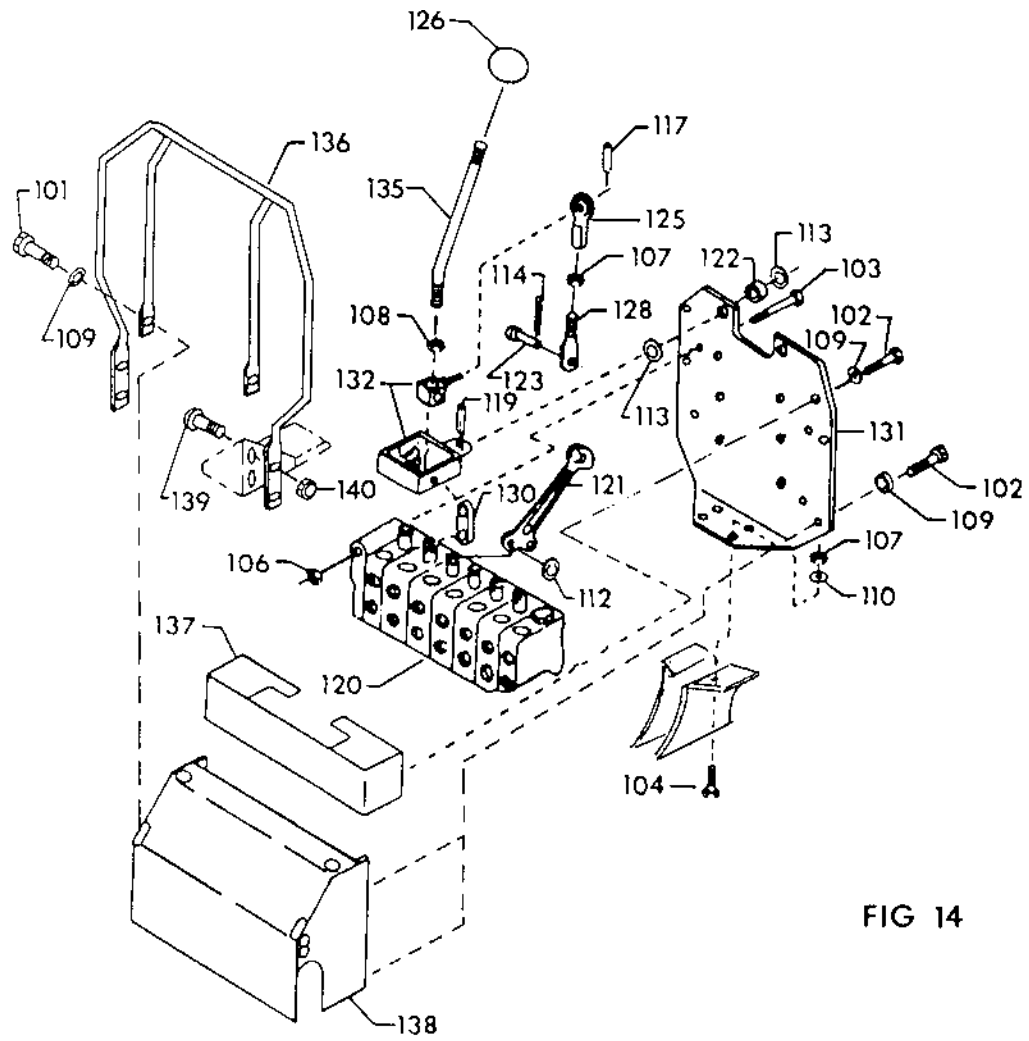

FIG 14

INDEX

PARTS LIST - FIG 14

Index	Description	Part No.	Index	Description	Part No.
101	Bolt, 5/16 NF x 3/4.....	114-102	121	Stabilizer Handle, Complete.	C42649
102	Bolt, 5/16 NF x 1".....	114-104	122	Bronze Bushing, 1-1/4 OD x 1" ID x 1".....	C42673
103	Bolt, 5/16 NC x 2-3/4.....	113-119	123	Clevis Pin, 1/4 Dia x 7/8	C42678
104	Bolt, 3/8 NF x 1-1/4 Gr 8...	114-201	125	Ball Joint, 3/8 NF Female..	C42683
106	Locknut, 5/16 NC.....	131-176	126	Handle Grip.....	C42684
107	Nut, 3/8 NF Gr 5.....	129-123	128	Handle Link.....	C42707
108	Jam Nut, 1/2 NC.....	C42639	130	Link.....	C42722
109	Lockwasher, 5/16.....	192-20	131	Valve Plate with Bushings ...	C42723
110	Lockwasher, 3/8.....	192-21	132	Linkage Pivot Weldment.....	C42724
112	Flat Washer, 3/16.....	195-513	135	Control Handle.....	C42728
113	Machine Bushing, 1-1/2 OD x 1" ID x 18 Ga.....	C42643	136	Handle Loop.....	C42726
114	Cotter Pin, 3/32 x 3/4.....	132-320	137	Control Shroud.....	C42725
117	Roll Pin, 5/32 x 3/4.....	138-73	138	Valve Shroud.....	C42727
119	Roll Pin, 3/8 x 1-3/4.....	138-176	139	Carriage Bolt, 3/8 NC x 1"...	111-371
120	Control Valve, Complete....	C42693	140	Locknut, 3/8.....	131-1216

Model 80A
BOOM, DIPPERSTICK AND BUCKET

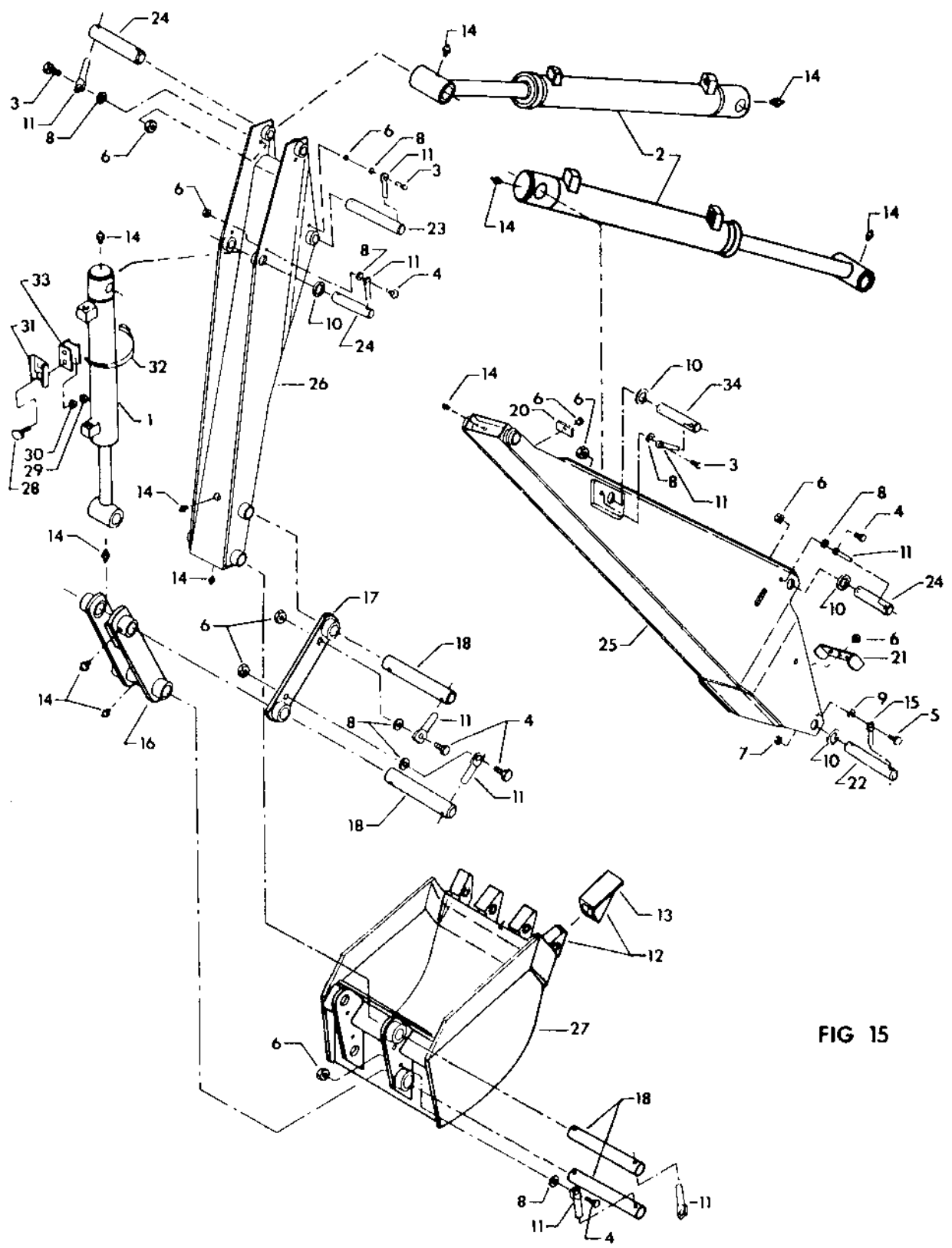





FIG 15

INDEX

PARTS LIST - FIG 15

Index	Description	Part No.	Index	Description	Part No.
1	Hydraulic Cylinder-Bucket..	C42635	20	Hose Retainer.....	C42710
2	Hydraulic Cylinder- Boom/Dipperstick.....	C42636	21	Hose Strap.....	C42712
3	Bolt, 5/16 NF x 3/4.....	114-102	22	Pin, 1" Dia. x 8-3/16.....	C42714
4	Bolt, 5/16 NF x 7/8.....	114-101	23	Pin, 1" Dia. x 6-7/8.....	C42715
5	Bolt, 3/8 NF x 1".....	114-200	24	Pin, 1" Dia. x 5-5/8.....	C42716
6	Locknut, 5/16 NF.....	131-1169	25	Boom Weldment.....	C42730
7	Locknut, 3/8 NF.....	131-1133	26	Dipperstick Weldment.....	C42731
8	Flat Washer, 5/16 SAE.....	195-521	27	Bucket Complete - 9 inch..	C42583
9	Flat Washer, 3/8 SAE.....	195-525	27	Bucket Complete - 13 inch..	C42584
10	Machine Bushing, 1-1/2 OD x 1" ID x 18 GA.....	C42643	27	Bucket Complete - 16 inch..	C42585
11	Retainer, 5/16.....	C42720	27	Bucket Complete - 19 inch..	C42586
12	Bucket Tooth and Shank.....	C42681	27	Bucket Complete - 24 inch..	C42587
13	Bucket Tooth Only.....	C28530	27	Bucket Complete - 36 inch..	C42588
14	Grease Fitting.....	219-10	28	Carriage Bolt, 5/16 NC x 3/4.....	111-132
15	Pin Retainer - Small.....	C42697	29	Nut, 5/16 NC.....	129-102
16	Bucket Link Weldment.....	C42699	30	Lockwasher, 5/16.....	192-20
17	Guide Link Weldment.....	C42706	31	SMV Socket.....	C31725
18	Pin, 1" Dia. x 7-3/8.....	C42702	32	Hose Clamp.....	214-260
			33	SMV Socket Mount.....	C31526
			34	Pin, 1" Dia. x 6".....	C42733

TORQUE VALUES			
Common bolts and nuts.		Tightening Torque ± 20%	
SIZE	GRADE 2 	GRADE 5 	GRADE 8 
1/4-20 NC	70 in lb	115 in lb	165 in lb
1/4-28 NF	85 in lb	140 in lb	200 in lb
5/16-18 NC	150 in lb	250 in lb	350 in lb
5/16-24 NF	165 in lb	270 in lb	30 ft lb
3/8-16 NC	260 in lb	35 ft lb	50 ft lb
3/8-24 NF	300 in lb	40 ft lb	60 ft lb
7/16-14 NC	35 ft lb	55 ft lb	80 ft lb
7/16-20 NF	45 ft lb	75 ft lb	105 ft lb
1/2-13 NC	50 ft lb	80 ft lb	115 ft lb
1/2-20 NF	70 ft lb	105 ft lb	165 ft lb
9/16-12 NC	75 ft lb	125 ft lb	175 ft lb
9/16-18 NF	100 ft lb	165 ft lb	230 ft lb
5/8-11 NC	110 ft lb	180 ft lb	260 ft lb
5/8-18 NF	140 ft lb	230 ft lb	330 ft lb
3/4-10 NC	150 ft lb	245 ft lb	350 ft lb
3/4-16 NF	200 ft lb	325 ft lb	470 ft lb

NOTE - See tractor instruction manual or your tractor dealer for tightening of metric bolts.

Model 80A SWING FRAME AND ATTACHING PARTS

PARTS LIST - FIG 16

Index	Description	Part No.	Index	Description	Part No.
38	Hydraulic Cylinder - Swing....	C42637	48	Quick Release Pin - Long...	C42680
39	Bolt, 5/16 NF x 1".....	114-104	49	Grease Fitting.....	219-10
40	Bolt, 5/16 NF x 1-1/4.....	114-100	50	Pin Retainer - Small.....	C42697
41	Bolt, 3/8 NF x 1".....	114-200	51	Thrust Washer.....	C42703
42	Locknut, 5/16 NF.....	131-1169	52	Swing Frame Assembly (includes items 47 & 60)...	C42729
43	Lockwasher, 3/8.....	192-21	53	Swing Link Weldment.....	C42705
44	Machine Bushing, 1-1/2 OD x 1" ID x 18 GA.....	C42643	55	Hose Retainer.....	C42710
45	Cotter Pin, 1/4 x 1-1/2.....	132-349	56	Hose Bracket.....	C42711
46	Cotter Pin, 5/16 x 2-1/2.....	C42644	57	Hose Strap.....	C42712
47	Bronze Bearing, 1-1/4 OD x 1" ID x 1".....	C42673	58	Pin, 1" Diameter x 5-1/2.....	C42717
			59	Pin, 1" Diameter x 4-1/8.....	C42719
			60	Bronze Bushing, 1-3/4 OD x 1-1/2 ID x 1"....	C42674

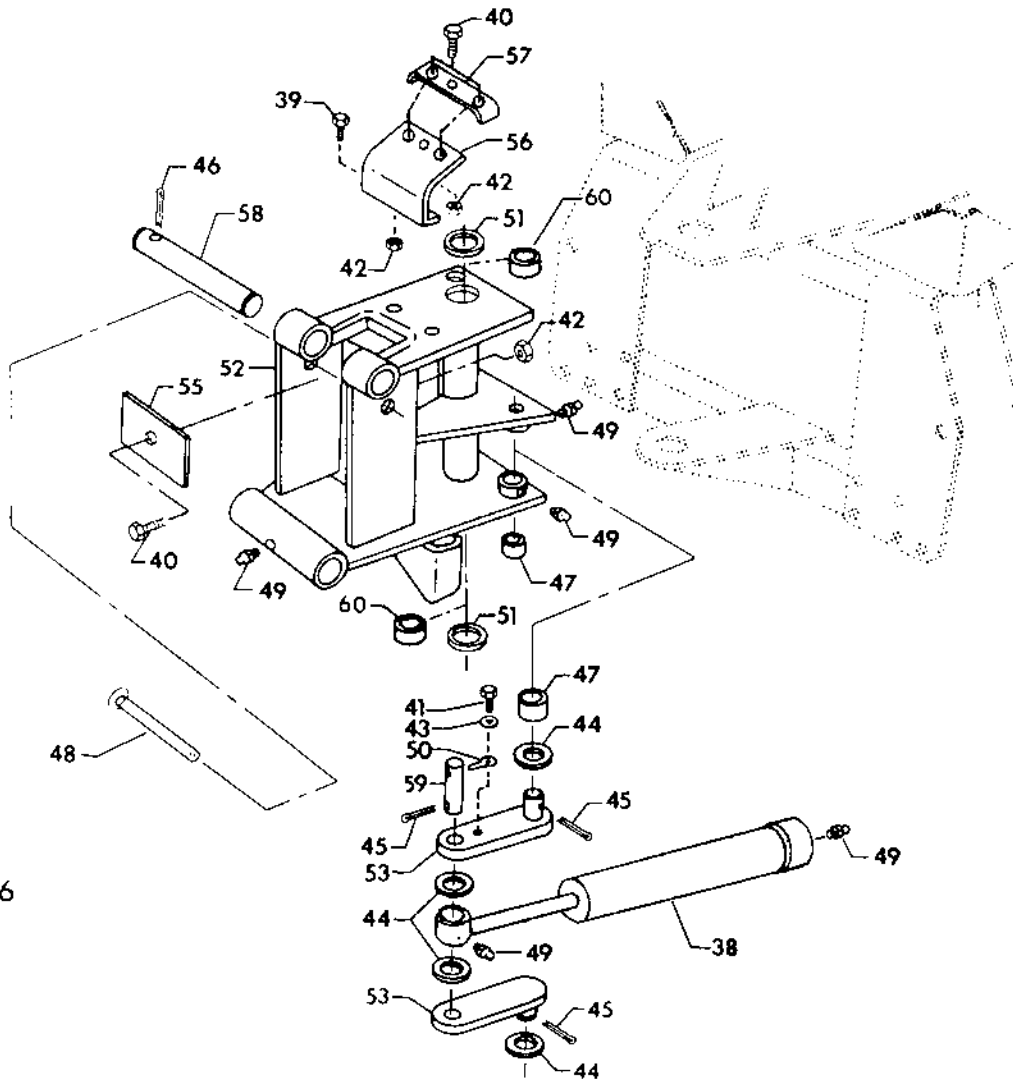

FIG 16

Model 80A MAINFRAME AND ATTACHING PARTS

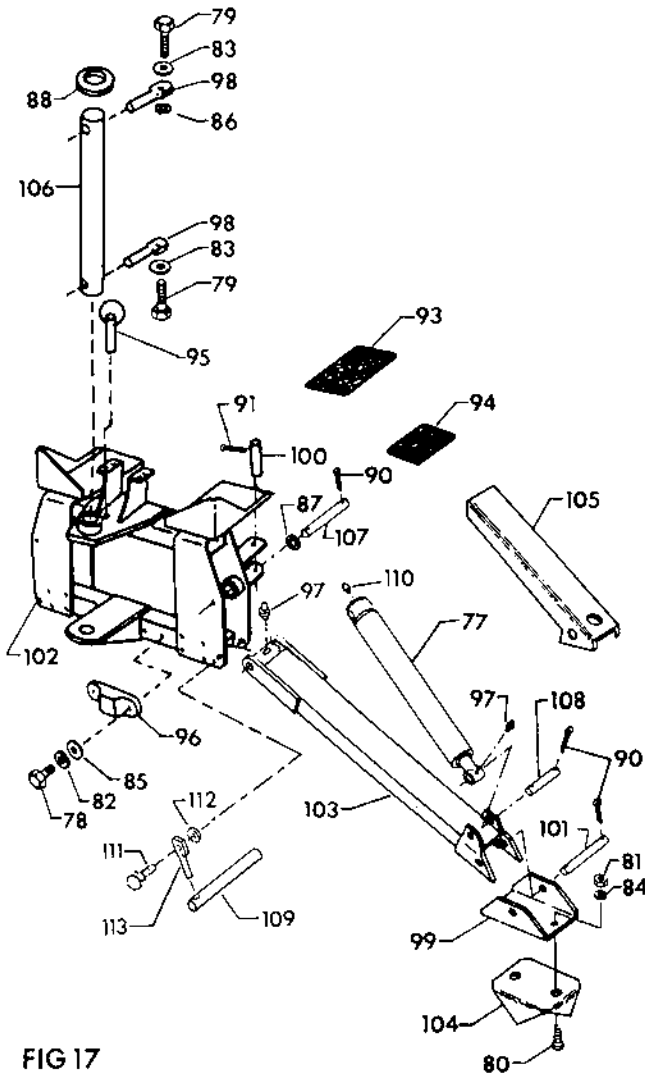

FIG 17

PARTS LIST - FIG 17

Index	Description	Part No.
77	Hydraulic Cylinder - Stabilizer.....	C42634
78	Bolt, 5/16 NF x 1-1/4.....	114-100
79	Bolt, 1/2 NF x 1".....	114-409
80	Bolt, 5/8 NC x 1-1/4 Gr 5.....	113-606
81	Nut, 5/8 NC.....	129-107
82	Lockwasher, 5/16.....	192-20
83	Lockwasher, 1/2 Shakeproof.....	192-80
84	Lockwasher, 5/8.....	192-25
85	Flat Washer, 5/16.....	195-521
86	Flat Washer, 1/2 SAE.....	195-533
87	Flat Washer, 5/8 SAE.....	195-541
88	Machine Bushing, 2-1/4 OD x 1-1/2 ID x 16 GA.....	C42642
90	Cotter Pin, 3/16 x 1-1/4.....	132-312
91	Cotter Pin, 1/4 x 1-1/2.....	132-349
93	Foot Pad - Large.....	C42675
94	Foot Pad - small.....	C42676
95	Quick Release Pin - Short.....	C42679
96	Bumper.....	C42682
97	Grease Fitting.....	219-10
98	Pin Retainer - Large.....	C42698
99	Stabilizer Pad.....	C42700
100	Pin, 1" Diameter x 4-1/4.....	C42701
101	Pin, 5/8 Dia. x 4-15/16.....	C42704
102	Mainframe Weldment.....	C42734
103	Stabilizer Weldment.....	C42735
104	Stabilizer Shoe.....	C42708
105	Stabilizer Shield.....	C42709
106	Main Pivot Shaft.....	C42713
107	Pin, 5/8 Dia. x 5-5/8.....	C42721
108	Pin, 5/8 Dia. x 3-7/8.....	C42718
109	Pin, 5/8 Dia. x 5-5/8.....	C42732
110	Grease Fitting, 45°.....	219-37
111	Bolt, 5/16 NF x 7/8 Gr.5.....	114-101
112	Locknut, 5/16 NF.....	131-1169
113	Pin Retainer - Small.....	C42720

Model 80A
HOSES, SECTIONS 2,5 AND 6

PARTS LIST - FIG 18

Index	Description	Part No.	Index	Description	Part No.
175	Hydraulic Hose, 3/8 NPT M x 3/8 NPT M x 100".....	C42690	184	Check Valve.....	C4265
176	Hydraulic Hose, 3/8 NPT M x 3/8 NPT M x 118".....	C42691	185	Plastic Tie.....	C22947
177	Hydraulic Hose, 3/8 NPT M x 3/8 NPT M x 65".....	C42688	186	Hose Sleeve, 1-9/16 ID x 18".....	C42685
178	Hydraulic Hose, 3/8 NPT M x 3/8 NPT M x 92".....	C42689			
179	Adapter Union, 1/4 NPT M x 3/8 NPT F.....	218-910			
180	Adapter Union, 1/2 NPT M x 1/2 NPT F x 45°.....	218-938			
181	Adapter Union, 7/8-14 M x 1/2 NPT F x 90°.....	218-5201			
182	Adapter Union, 3/4-16 M x 3/8 NPT F x 90°.....	218-5387			
183	Hose Clamp.....	214-260			

FIG 18

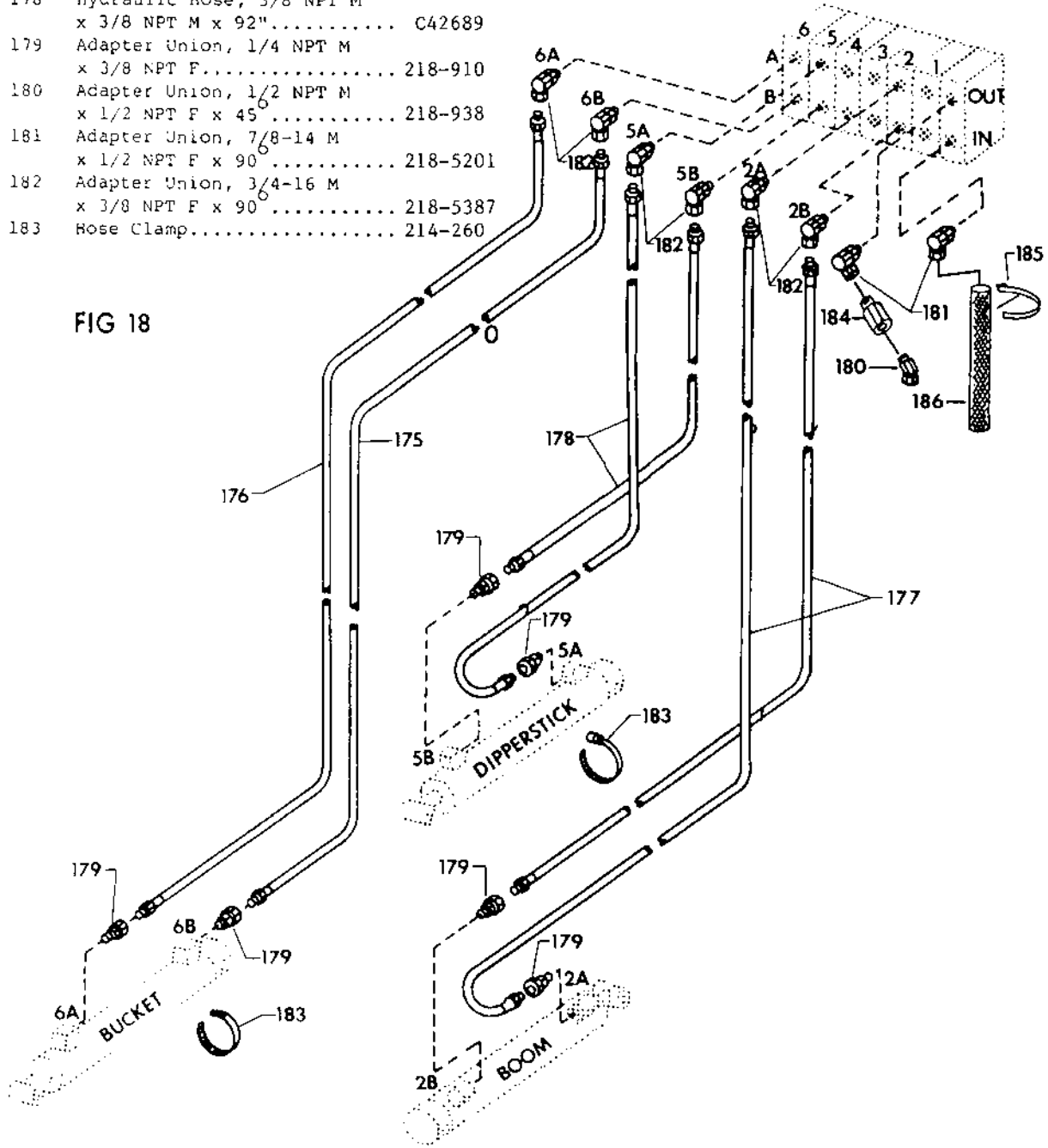

Model 80A

HOSES, SECTIONS 1,3 AND 4

PARTS LIST - FIG 19

Index	Description	Part No.	Index	Description	Part No.
197	Bolt, 5/16 NC x 2-1/2.....	113-111	203	Hydraulic Hose, 3/8 NPT M x 3/8 NPT M x 45".....	C42687
198	Nut, 5/16 NC.....	129-102	204	Adapter Union, 1/4 NPT M x 3/8 NPT F.....	218-910
199	Hydraulic Street Elbow, 3/8 NPT x 90°.....	217-1016	205	Adapter Union, 1/4 NPT M x 3/8 NPT F x 90°.....	218-948
200	Lockwasher, 5/16.....	192-20	206	Adapter Union, 3/4-16 M x 3/8 NPT F x 90°.....	218-5387
201	Cross-Over Relief, 1300 psi.....	C42671	207	Hose Clamp.....	214-260
202	Hydraulic Hose, 3/8 NPT M x 3/8 NPT M x 20".....	C42686			

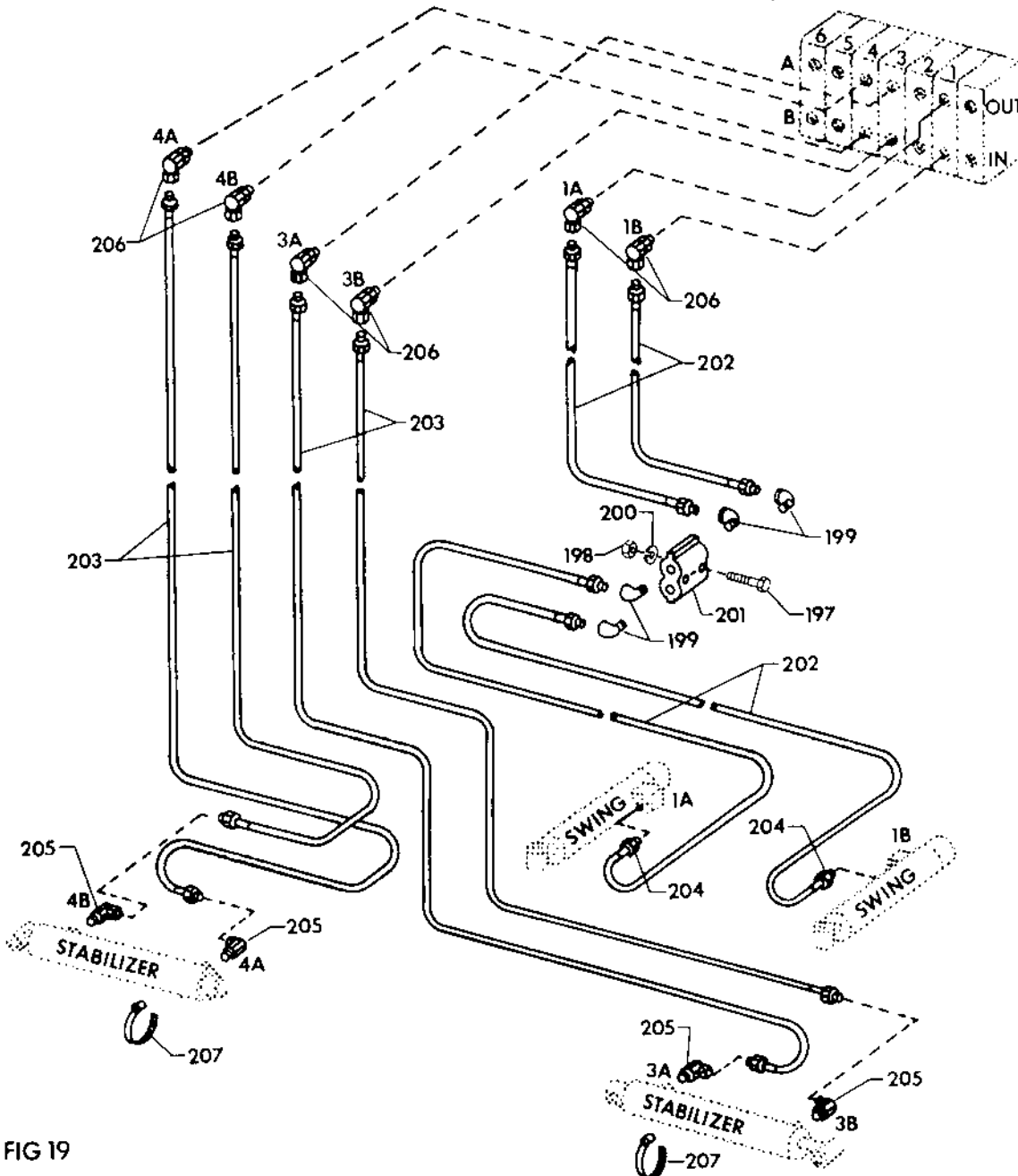
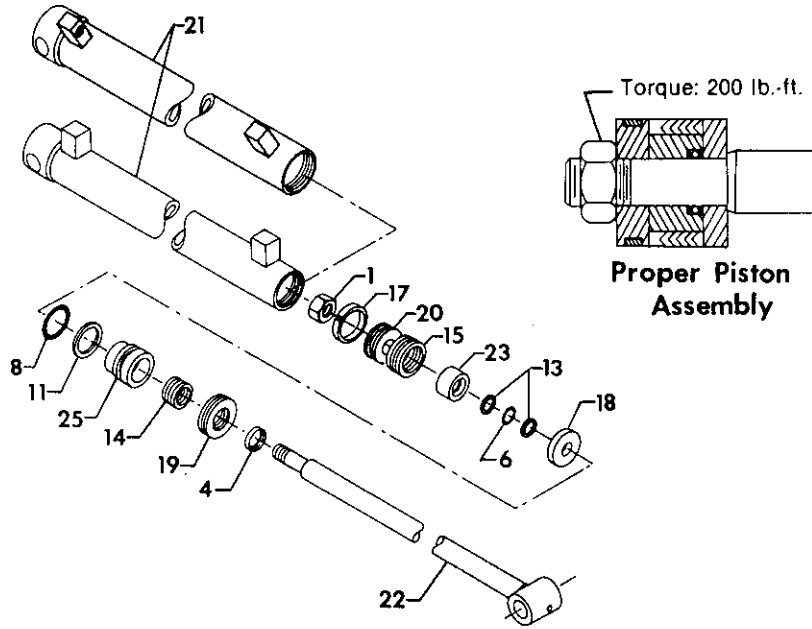

FIG 19

Model 80A CYLINDERS

Cylinder
Lift and Crowd
Part No. C42636
Cylinder
Bucket
Part No. C42635



Cylinder
Stabilizer
Part No. C42634

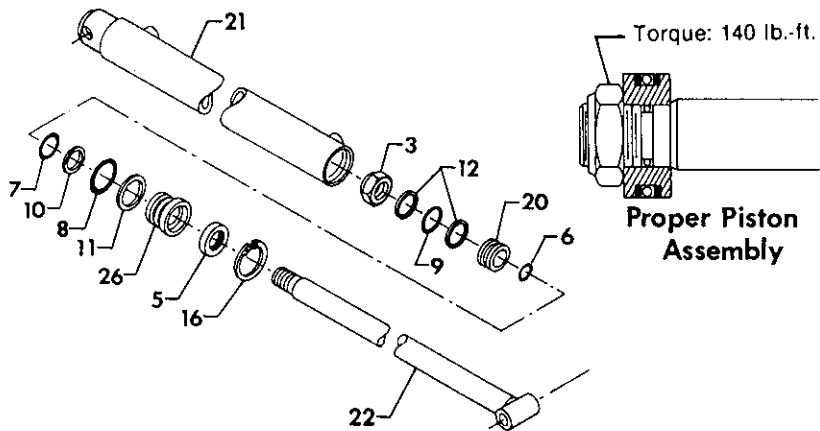

Cylinder
Swing
Part No. C42637

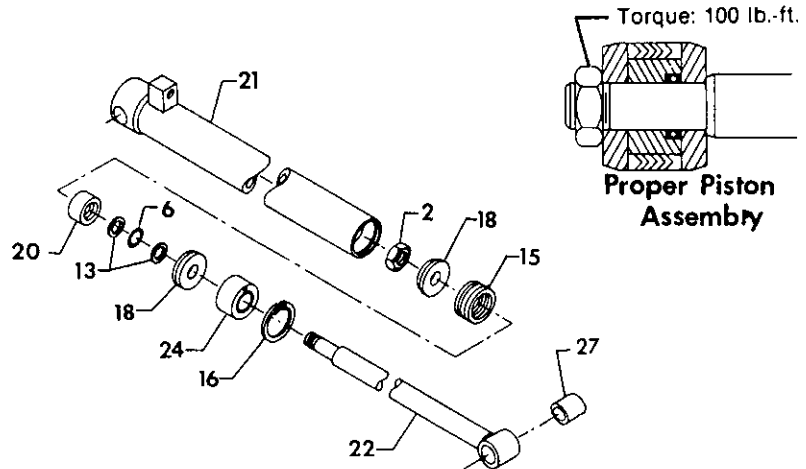

HYDRAULIC CYLINDERS - PARTS LISTS

Index	Description	C42636	C42635	C42634	C42637
1	Lock Nut, 3/4 NF Nyloc.....	C42638	C42638		
2	Jam Nut, 3/4 NF Nyloc.....				C42640
3	Jam Nut, 1" NF Nyloc.....			C42641	
4	Oil Seal, 1-1/4 OD x 1" ID.....	*	*		
5	Oil Seal, 1-5/8 OD x 1-1/8 ID.....			*	
6	O-Ring, 1" OD x 3/4 ID.....	*	*	*	*
7	O-Ring, 1-3/8 OD x 1-1/8 ID.....			*	
8	O-Ring, 2" OD x 1-3/4 ID.....	*	*	*	
9	O-Ring, 2" OD x 1-5/8 ID.....			*	
10	Back-Up Ring, 1-3/8 OD x 1-1/8 ID.....			*	
11	Back-Up Ring, 2" OD x 1-3/4 ID.....	*	*	*	
12	Back-Up Ring, 2" OD x 1-5/8 ID.....			*	
13	Back-Up Ring, 1" OD x 3/4 ID.....	*	*		*
14	Packing Assembly, 1-3/8 OD x 1" ID.....	*	*		
15	Packing Assembly, 2" OD x 1-1/2 ID.....	*	*		*
16	Retaining Ring, Internal.....			*	C42677
17	Wear Ring, 2" OD x 1-3/4 ID x 3/8.....	*	*		
18	Piston Washer.....	C42748	C42748		C42736
19	Gland Nut.....	C42737	C42737		
20	Piston.....	C42747	C42747	C42738	C42754
21	Cylinder Tube Weldment.....	C42751	C42751	C42741	C42753
22	Piston Rod Weldment.....	C42752	C42746	C42742	C42756
23	Piston Spacer, with O-Ring and Back-Ups.....	C42743	C42743		
24	Rod Guide Assembly.....				C42744
25	Gland, with O-Ring, Back-Up, and Packing.....	C42750	C42750		
26	Gland.....			C42739	
27	Bronze Bushing, 1" ID x 1-1/4 OD x 1-1/2.....				C42672
	For Complete Cylinder, order.....	C42636	C42635	C42634	C42637
	Seal Repair Kit (includes all Packings, Wear Rings, O-Rings, Back-Up Rings, and Wipers for one cylinder).....	C42749	C42749	C42740	C42755

* Not available as a separate repair part - order seal repair kit.

IMPORTANT: Replace Cylinder Nut (1, 2, or 3) any time nut must be removed, and torque to value shown on page 36.