



Ingersoll

**FRONT CUT TRACTORS
5018CD AND 5020V
Parts Catalog 8-3320**

[HOME](#)

[TRACTORS](#)

[ATTACHMENTS](#)

[INDEX](#)

[PAINT](#)

[ENGINES](#)

[GENERAL INFO](#)

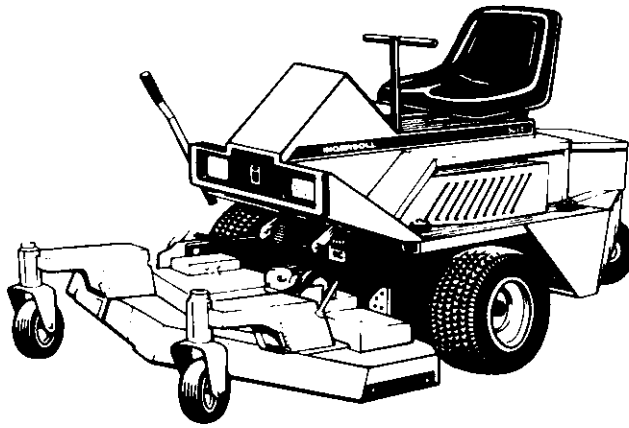

MODEL 5012, 5016 AND 5018 FRONT CUT MOWERS**PRODUCT IDENTIFICATION NUMBERS (P.I.N.)
OR SERIAL NUMBERS (S/N)**

The P.I.N. for your front cut mower is located on a sticker placed on the inside of the base near the battery. Other components will have the P.I.N. attached individually. Example (engines, transmissions, etc.).

ENGINE IDENTIFICATION

TRACTOR MODEL	ENGINE MODEL
5018CD*	BRIGGS Et STRATTON CORPORATION ENGINE MODEL 422447 SPEC. NO. 1277
5020V*	BRIGGS & STRATTON CORPORATION (VANGUARD) ENGINE MODEL 351447 SPEC. 1192

IMPORTANT NOTICE:

In this catalog Briggs & Stratton engine parts and warranty are handled by the engine manufacturer.

CONTACT YOUR LOCAL ENGINE DISTRIBUTOR

INDEX

There is an index at the front of this catalog. The front index is an alphabetical index of the major groups or assemblies.

ILLUSTRATION

Each illustration in this catalog shows a group of parts or components. These parts and components are aligned approximately as the parts and components on your machine. Each part and component in an illustration has a reference number. These reference numbers are in a list on the page opposite of the illustration. Next to the reference number is the part number, description and required quantity of the part shown in the illustration.

UAR - "Use as required" indicates that the part quantity is variable.

NSS - "Not sold separately" indicates that the part is only available as component of an assembly or the part must be purchased locally. If the part is an assembly component, the description will be indented under the assembly description in the parts list.

O/L - "Obtain locally"

- "Footnotes" are added to a part number when more information is needed for identification. They only relate to the part numbers indicated. All orders must include the following information:

1. Correct part number.

PARTS ORDERS

2. Complete description of part or component.
3. Total quantity of each part or component.
4. Product model number.
5. All necessary product identification numbers.
6. Method for sending the parts.
7. Complete and correct address.

CATALOG REVISIONS

As the product changes, new pages will be available for your catalog. A notice will be issued.

IMPORTANT: Put all revisions into the catalog as soon as possible.

RIGHT HAND AND LEFT HAND IDENTIFICATION

The words right hand (RH) and left hand (LH) as used in this catalog indicate the direction while you are in the operator's seat in the normal operating position.

INDENTED DESCRIPTIONS

An assembly can have many components. The components of an assembly are indicated by an indented description. The quantity for an indented part is the total needed for that complete assembly. See the example.

REF.	PART NO.	DESCRIPTION	REQ'D
	C 55159	CYLINDER ASSY - rear steering	1
28	C 56208	SOCKET ASSY - rear cylinder	1
29	C 55956	PLUG - adjusting, socket assy	1
30	C 55957	SEAT- socket, ball.....	2
31	C 56210	SPRING-socket	1
32	C 56209	SEAT - socket spring	1
33	G 45175	CLAMP ASSY - socket assy	1
	16- 836	BOLT-1/2"x2-1/4" N.F. hex.....	1
34	132- 104	PIN-cotter, 3/16"x3"	1
35	C 55889	STUD - ball, socket & cylinder	2
36	13- 410	BOLT-1/4"x5/8"N.C.,hex	4
37	92- 4	LOCK WASHER - 1/4"SAE	4

ALPHABETICAL INDEX

Engine and Attaching Parts – 5018CD.....	5	Drive Assembly L.H. (5020V)	27
Engine and Attaching Parts – 5020V.....	7	Steering Cable Kit (5020V)	29
Electrical Clutch	9	Lift Lever	29
Fuel System.....	9	Transmission and Drive Chains (5018CD)	31
Base Assembly	11	Cross Shaft, Transmission (5018CD)	33
Body.....	13	Pulley Drive and Cross Shaft (5020V)	33
Rear Weights	15	Hydraulic System (5020V)	35
Seat Lid and Steering	17	Wiring Diagram	37
Single Tail Wheel.....	19	Decals	39
Dual Tail Wheel – DW10	19	Deck Lift, Electric – Wench Style	41
Dual Tail Wheel – DTW10	21	Deck Lift, Electric – Cylinder Style	43
Parking Brake	23	ZT Transmission (5020V)	45
Drive Assembly R.H. (5020V).....	25	Pump, Hydro (5020V)	47



Ingersoll

Paint & Oil

INDEX

PAINT

Power Red Gloss

16-ounce Aerosol Can..... C28484
Quart C28485

Power White

16-ounce Aerosol Can..... C28812
Quart C28845

Power Yellow (Older 600 Series)

16-ounce Aerosol Can..... C28847
Quart C28848

Power Tan (6000 Series)

16-ounce Aerosol Can..... C28853
Quart C28854

Desert Sunset (Older 400 Series)

16-ounce Aerosol Can..... C28846
Quart C28852

Black, Semi Gloss

16-ounce Aerosol Can..... C28849
Quart C28850

Black, High Heat

16-ounce Aerosol Can..... C28851

Silver

16-ounce Aerosol Can..... C30870

M & W Plum

16-ounce Aerosol Can..... 10-5688

Grazer Grey

16-ounce Aerosol Can..... C38444
Quart C38982

Odyssey Charcoal Grey

16-ounce Aerosol Can..... C47171

HYDRAULIC OIL

20W40, Use 32 Degrees and above.
12-Quart Case..... C32778

5W20, Use Below 32 Degrees.
12-Quart Case..... C32777

ENGINE AND ATTACHING PARTS (5018CD) BRIGGS AND STRATTON

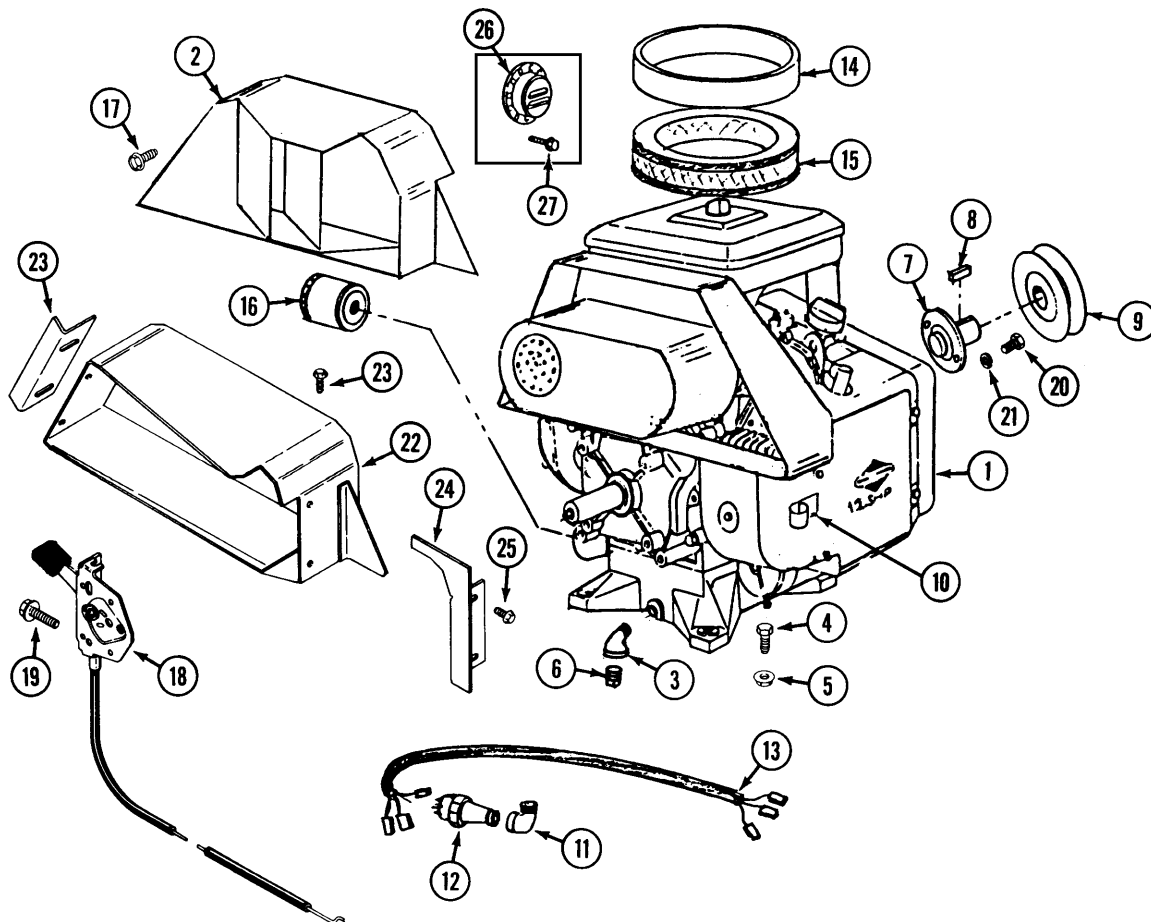

**ENGINE AND ATTACHING PARTS (5018CD)
BRIGGS AND STRATTON
(See your local distributor for internal parts and warranty)**

REF.	PART NO.	DESCRIPTION	REQ'D
1	C41674	ENGINE - Briggs & Stratton model 422447, Spec. 1277 (18 hp) (5018CD)	1
2	C37533	DUCT - air (use before S/N 14178235)	1
3	221-1413	ELBOW - street 3/8"	1
4	113-104	BOLT - 5/16" - 18 x 1-1/4"	4
5	131-911	NUT - 5/16" - 18	4
6	C37546	PLUG - pipe 3/8"	1
7	C37537	SHAFT - stub	1
8	C41015	KEY - 1/4" x 1/4" x 1"	1
9	C37539	PULLEY - drive (use C32199 set screw)	1
10	C32455	RETAINER - starter cable	2
11	221-411	ELBOW - street 1/8"	1
12	C37531	UNIT - oil sending	1
13	C42240	HARNESS - wire	1
14	C37543	PRECLEANER	1
15	C37544	FILTER - air	1
16	C34374	FILTER - oil	1
17	121-21	BOLT - 1/4" - 20 flange lock	7
18	C37819	CABLE - choke	1
18	C37820	CABLE - throttle	1
19	C39403	SCREW - #12 x 1/2"	4
20	113-207	BOLT - 3/8" - 16 x 1"	2
21	192-21	LOCKWASHER - 3/8"	2
22	C45077	DUCT - air (use S/N 14178235 and after)	1
23	C45078	DEFLECTOR - air, front (use S/N 14178235 and after)	1
24	C45079	DEFLECTOR - air, rear (use S/N 14178235 and after)	1
25	187-1328	BOLT - #8 - 18 x 3/8"	4
26	C33444	DEFLECTOR - exhaust	1
27	187-1041	SCREW - #8 - 32 x 3/8"	4

INDEX

**ENGINE AND ATTACHING PARTS
BRIGGS Et STRATTON VANGUARD MODEL (5020V)**

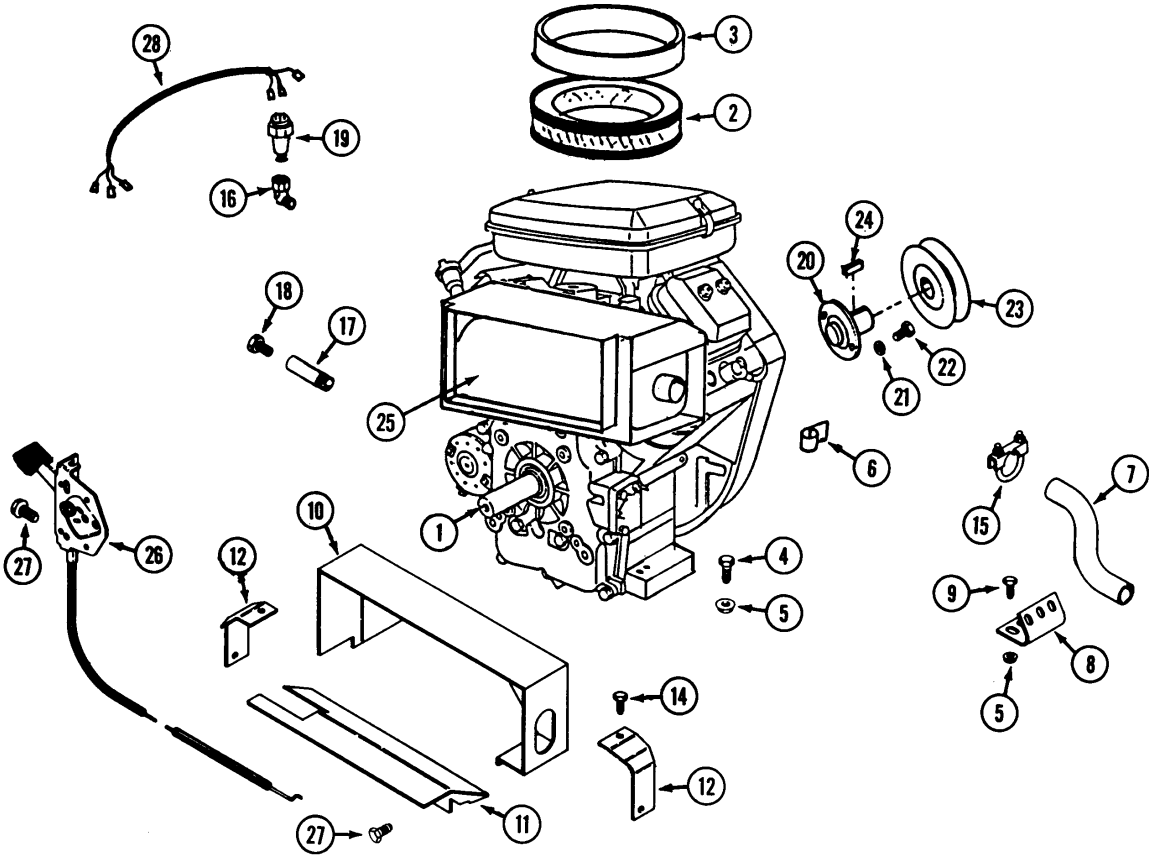

INDEX

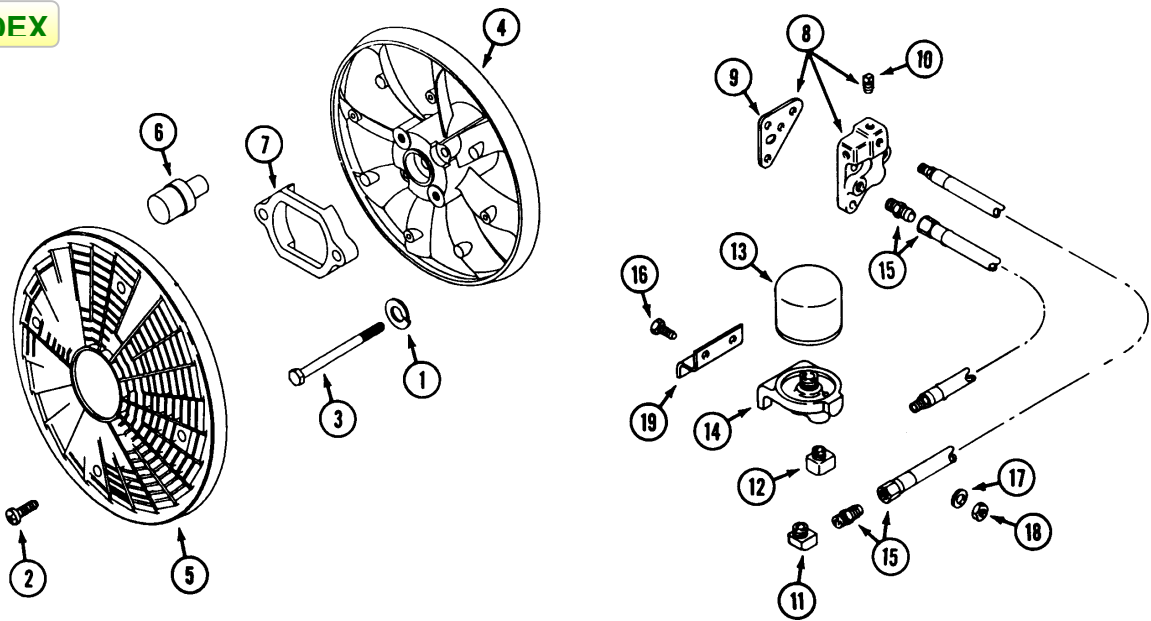

INDEX

**ENGINE AND ATTACHING PARTS
BRIGGS Et STRATTON VANGUARD MODEL (5020V)
(See your local engine dealer for other parts and repairs)**

REF.	PART NO.	DESCRIPTION	REQ'D
1	C45915	ENGINE - Briggs & Stratton Vanguard Model (20 hp) (5020V).....	1
2	C37544	ELEMENT - air cleaner	1
3	C37543	PRE-CLEANER.....	1
4	113-104	BOLT - 5/16" - 18 x 1-1/4".....	4
5	131-911	NUT - 5/16" - 18 flange lock.....	5
6	C32455	CLIP- "J"	2
7	C44244	PIPE - exhaust	1
8	C44243	BRACKET - exhaust pipe.....	1
9	113-103	BOLT - 5/16" - 18 x 1"	1
10	C45105	DUCT - muffler, upper.....	1
11	C45109	DUCT - bottom.....	1
12	C45111	SUPPORT - duct front.....	1
14	C45273	SCREW - M6 x 10.....	3
15	C28294	CLAMP - exhaust.....	2
16	217-1085	FITTING - street elbow, 1/4" NPT 45.....	1
17	C33949	NIPPLE - pipe 3.5"	1
18	218-5154	PLUG - 1/2" - 20.....	1
19	C37531	UNIT - oil sending	1
20	C37537	SHAFT - stub	1
21	192-21	LOCKWASHER - 3/8".....	2
22	113-207	BOLT - 3/8" - 16 x 1"	2
23	C37539	PULLEY - engine (use 83-55 set screw).....	1
24	C41015	KEY - 1/4" x 1/4 x 1".....	1
25	C44862	MUFFLER	1
26	C37819	CABLE - choke.....	1
26	C37820	CABLE - throttle	1
27	C39403	SCREW - #12 x 1/2".....	4
28	C42240	HARNESS - wire	1

INDEX**BOOSTER FAN AND REMOTE OIL FILTER (5020V)**

1	C44857	LOCKWASHER.....	2
2	BR93805	SCREW.....	4
3	C44858	SCREW.....	2
4	C44859	FAN - booster.....	1
5	C44860	SCREEN - rotating.....	1
6	C44861	PIN - pilot.....	1
7	C46079	SPACER - fan	1
8	C45094	ADAPTOR - oil.....	1
9	C34361	GASKET - adaptor	1
10	C34239	PLUG - pipe 1/8"	1
11	C44865	ELBOW - 90°.....	1
12	C44866	ELBOW - 90°.....	1
13	C34374	FILTER - oil.....	1
14	C44868	MOUNT - oil filter	1
15	C44869	HOSE AND FITTING	2
16	113-3	BOLT - 1/4" - 20 x 3/4"	3
17	195-102	WASHER - 5/16"	2
18	131 -934	NUT - 1/4" - 20	3
19	C44328	BRACKET - mount.....	1

INDEX

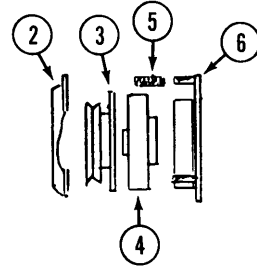
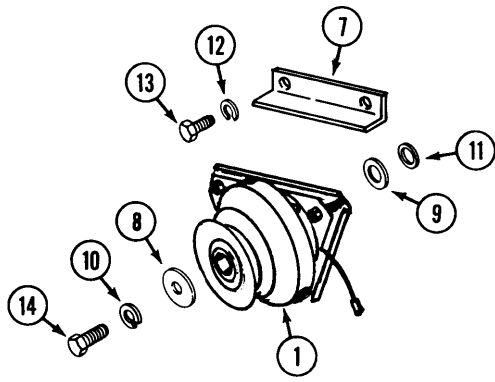

INDEX

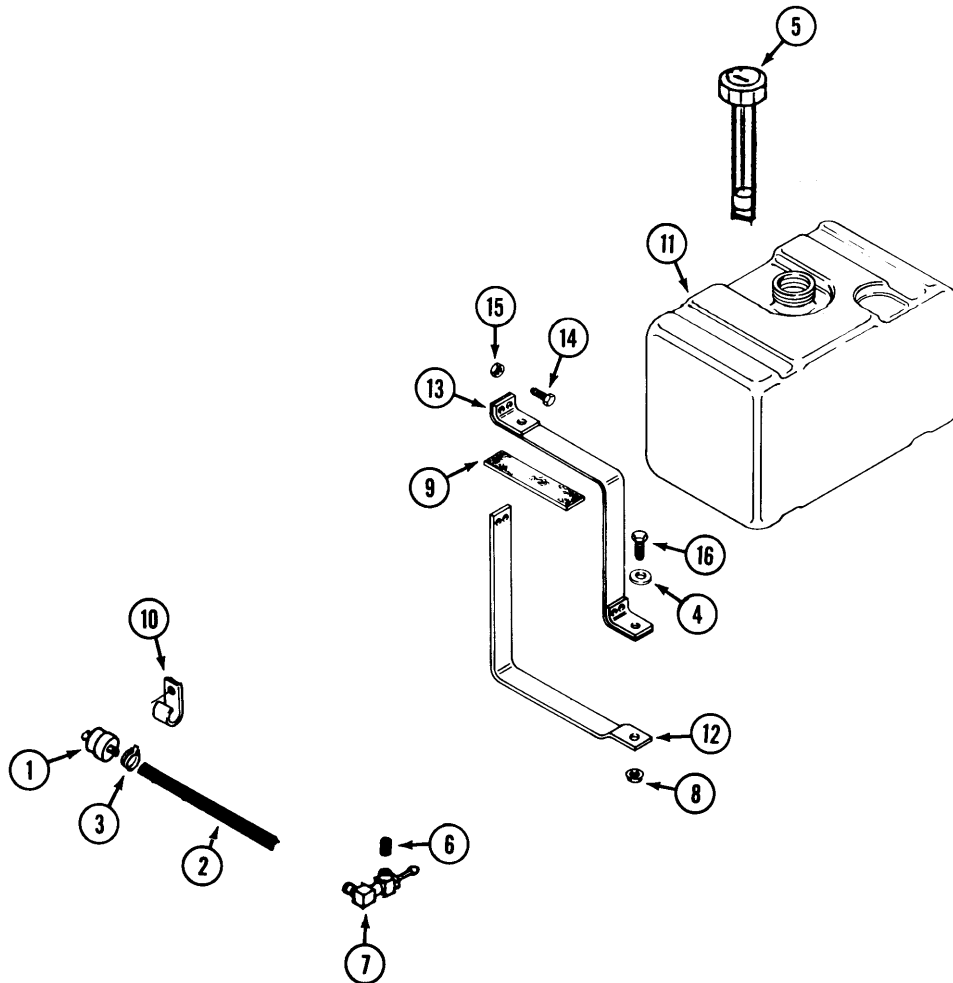

INDEX**ELECTRIC CLUTCH (PTO)**

REF.	PART NO.	DESCRIPTION	REQ'D
1	C37511	CLUTCH ASSEMBLY	1
2	C37549	BRAKE - clutch	1
3	C37550	ARMATURE - clutch	1
4	C37551	ROTOR - clutch.....	1
5	C37552	KIT-spring and nut (3each)	1
6	C37553	COIL - clutch	1
7	C37562	BRACKET - clutch stop.....	1
8	C31615	WASHER - retaining	1
9	NSS	WASHER - 1"	1
10	192-21	LOCKWASHER - 3/8"	1
11	C31614	WASHER - 1-1/8"	1
12	192-22	LOCKWASHER - 7/16"	2
13	113-335	BOLT - 7/16" - 14 x 3/4"	2
14	114-203	BOLT - 3/8" - 24 x 1-1/2"	1

INDEX**FUEL SYSTEM**

1	C37554	FILTER - fuel.....	1
2	C44027	HOSE - fuel (cut to length)	1
3	214-103	CLAMP - hose.....	4
4	195-521	WASHER - 5/16"	2
5	C45334	CAP - fuel tank (with gauge) (2-1/4" threads) (use on plastic tank).....	1
6	221-1101	NIPPLE - pipe 1/8"	1
7	C37811	VALVE - shut off.....	1
8	131-911	NUT - 5/16" - 18 flange lock	2
9	C34189	CUSHION.....	2
10	C32455	CLIP - "J" fuel line	1
11	C45333	TANK - fuel (2-1/4" filler tube) (plastic)	1
12	C45061	BRACKET - fuel tank	2
13	C45062	STRAP - fuel tank	2
14	113-5	BOLT - 1/4" - 20 x 1-1/2"	2
15	131-71	NUT - 1/4" - 20 lock.....	2
16	113-103	BOLT - 5/16" - 18 x 1"	2

INDEX

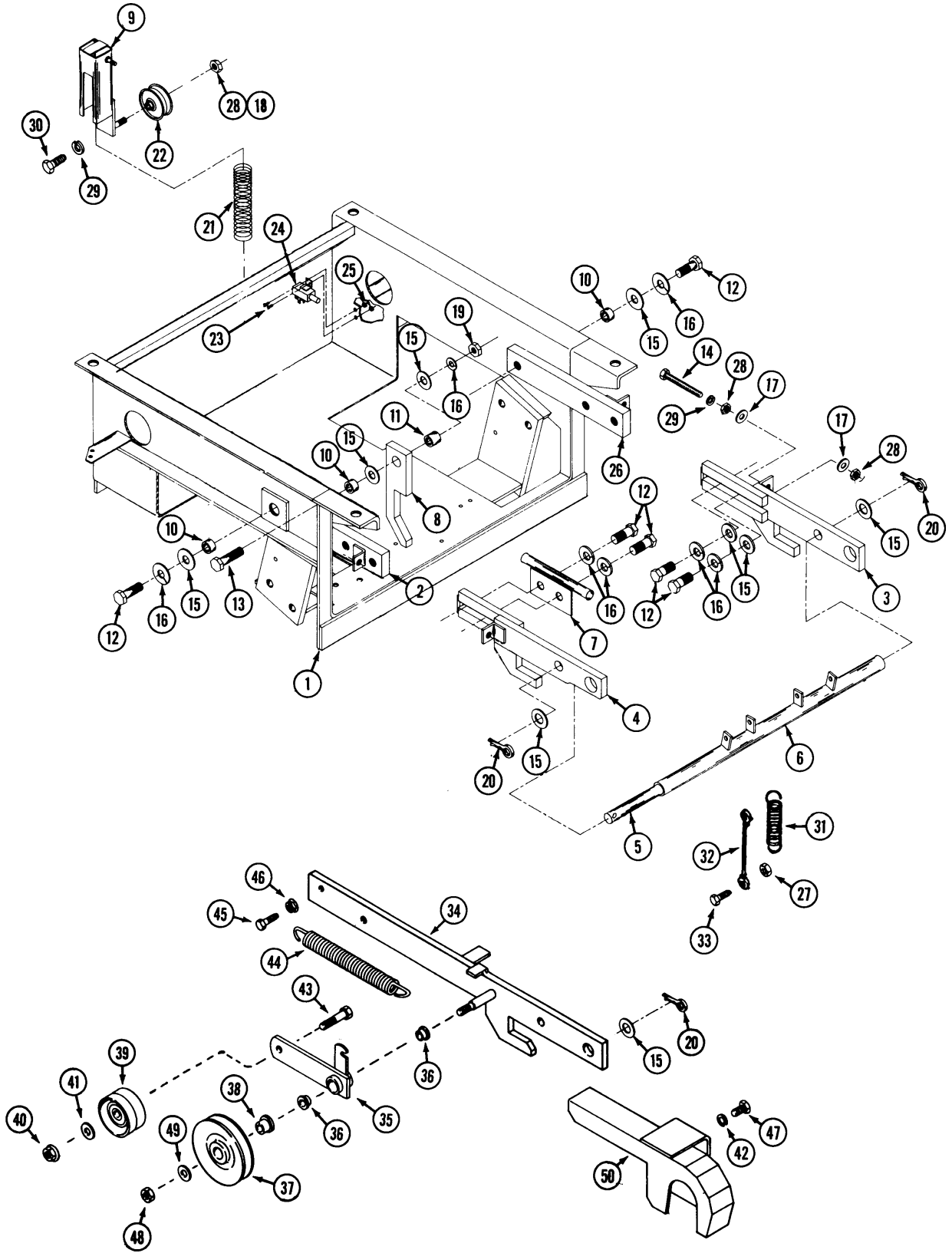

BASE ASSEMBLY

REF.	PART NO.	DESCRIPTION	REQ'D
1	C45924	BASE - 5018CD	1
1	C46081	BASE - 5020V	1
2	C37575	ARM - deck lift R.H. (5018CD).....	1
3	C37574	ARM - front L.H. (5018CD).....	1
4	C37573	ARM - front R.H. 5018CD)	1
5	C37578	PIN - cross bar	1
6	C37579	BAR - cross	1
7	C37577	TUBE - wire	1
8	C37583	LOCK - forward nose down.....	2
9	C37603	TUBE - drive idler (5018CD)	1
10	C37576	BUSHING - deck lift arm (3/8" long).....	3
11	C37586	BUSHING - pivot (1/2" long).....	1
12	113-417	BOLT - 1/2" - 13 x 1-1/4"	6
13	113-441	BOLT - 1/2 - 13 x 2-1/4	1
14	113-210	BOLT - 3/8" - 16 x 3"	2
15	195-106	WASHER - 1/2"	8
16	192-23	LOCKWASHER - 1/2"	7
17	195-104	WASHER - 3/8"	4
18	131-938	NUT - flange lock 3/8" - 16	1
19	129-105	NUT- 1/2" - 13	1
20	132-310	PIN - cotter 1/8" x 1".....	2
21	C37595	SPRING - idler tension.....	1
22	C38864	PULLEY - idler (5018CD).....	1
23	182-553	SCREW - machine #10-32x5/8".....	2
24	C37521	SWITCH - safety	1
25	193-1000	NUT - lock #10-32	2
26	C38594	ARM - deck lift L.H. (5018CD).....	1
27	131-71	NUT - lock 1/4" - 20.....	4
28	129-103	NUT - 3/8"- 16	5
29	192-21	LOCKWASHER - 3/8"	3
30	113-213	BOLT - 3/8" - 16 x 2-1/4" (5018CD)	1
31	C37815	SPRING - lift assist	2
32	C37816	CABLE - lift.....	2
33	113-4	BOLT - 1/4" - 20 x 1"	4
34	C44250	ARM - deck R.H. (5020V)	1
34	C45099	ARM - deck L.H. (5020V)	1
35	C45095	ARM - idler (5020V)	1
36	C27501	BEARING - flange (5020V)	2
37	C25370	PULLEY - "V" idler (5020V).....	1
38	C45102	BUSHING - pulley (5020V)	1
39	C45121	PULLEY - idler, flat (5020V).....	1
40	131-938	NUT - 3/8" - 16 flange lock	1
41	195-104	WASHER - 3/8" (5020V)	1
42	192-20	LOCKWASHER.....	2
43	113-219	BOLT - 3/8" - 16 x 2" (5020V)	2
44	C44242	SPRING - extension (5020V).....	1
45	113-103	BOLT - 5/16"- 18x 1"(5020V)	1
46	131-911	NUT - 5/16" - 18 flange lock (5020V)	1
47	113-102	BOLT - 5/16" - 18 x 3/4"	2
48	131-1182	NUT - 1/2" - 13 lock (5020V).....	1
49	195-533	WASHER - 1/2" (5020V)	1
50	C44403	GUARD - belt (5020V)	1

INDEX

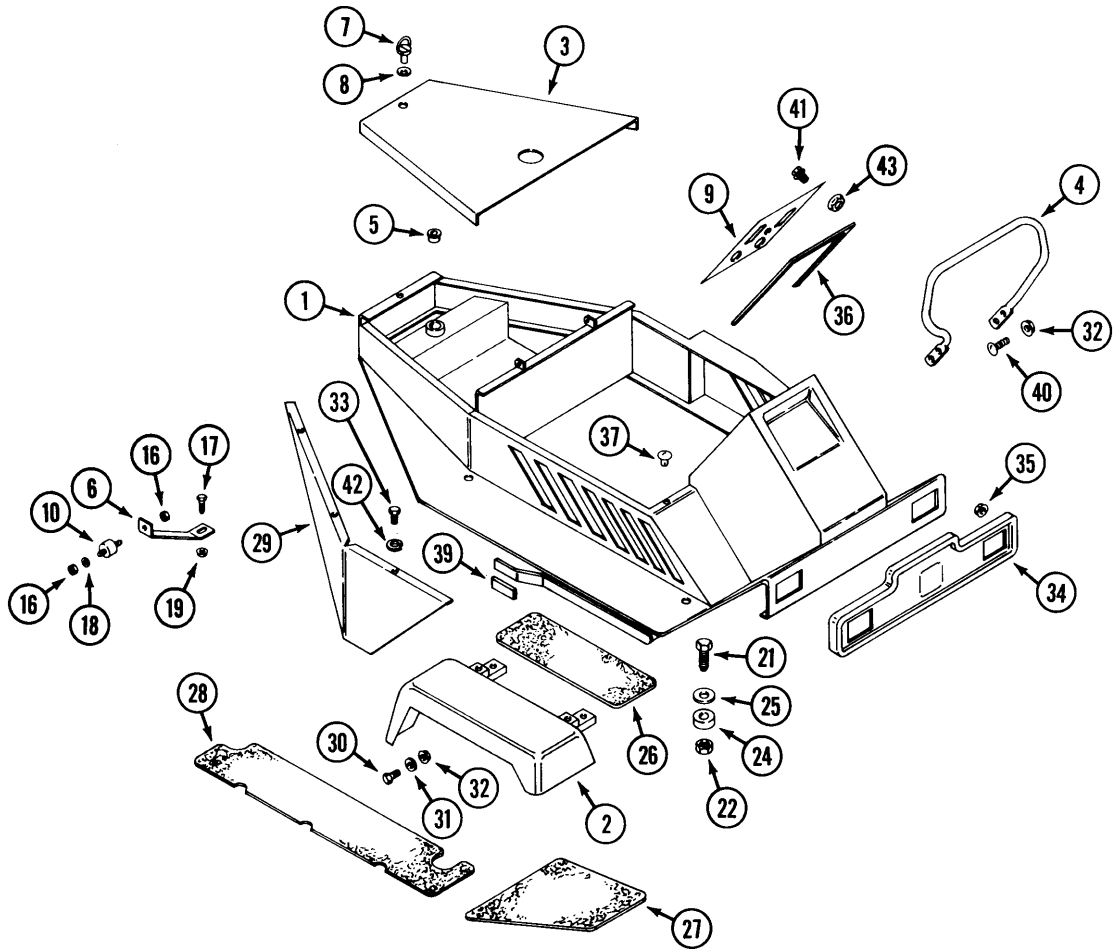

REF.	PART NO.	DESCRIPTION	REQ'D
1	C44954	BODY	1
2	C39534	FENDER - R.H. (shown) (5020V)	1
2	C40645	FENDER - L.H. (5020V)	1
3	C41163	COVER - back	1
4	C44844	BAR - handle (optional)	1
5	C37824	BEARING - rear wheel fork	2
6	C45084	BRACKET - support	2
7	C41944	STUD - fastener	1
8	C41945	GROMMET - fastener	1
9	C42053	PANEL - dash	1
10	C43012	MOUNT - rubber	2
11	193-1000	NUT - lock #10-32	2
16	131-71	NUT - 1/4" - 20 lock	4
17	113-102	BOLT - 5/16" x 18 x 3/4"	2
18	195-102	WASHER - 1/4"	4
19	131-911	NUT - 5/16" - 18 flange lock	2
20	131-1352	NUT - 3/8" - 16 flange lock	2
21	113-425	BOLT - 1/2" - 13 x 3"	4
22	131-70	NUT - 1/2" lock	4
24	C37818	MOUNT - body, rubber	8
25	C37581	WASHER - mount, body	4
26	C39524	PAD - fender (5020V)	2
27	C39525	PAD - footrest, front L.H.	1
27	C39526	PAD - footrest, front R.H. (shown)	1
28	C44955	PAD - footrest, rear L.H. (5018CD)	1
28	C44956	PAD - footrest, rear R.H. (5018CD)	1
28	C44957	PAD - footrest, rear L.H. (5020V)	1
28	C44958	PAD - footrest, rear R.H. (5020V)	1
29	C41175	SKIRT - L.H. (5018CD)	1
29	C41179	SKIRT - R.H. (5018CD)	1
29	C44975	SKIRT - L.H. (5020V)	1
29	C44977	SKIRT - R.H. (5020V)	1
30	113-118	BOLT - 5/16" - 18 x 5/8"	4
31	195-103	WASHER - 5/16"	4
32	131-911	NUT - 5/16" - 18 flange lock	8
33	C34808	BOLT - 1/4" - 20 x 3/4" self-tap (5018CD)	8
33	C42056	BOLT - 5/16" - 18 x 5/8" black	10
33	C42057	BOLT - 5/16" - 18 x 1-3/4" black	4
34	C44973	PLATE - face	1
35	131-971	NUT - #8 - 32 flange lock	2
36	C44035	TRIM - 27" (cut to length)	1
37	C35067	BUMPER - nylon	4
39	C37631	GRIP - handle	1
40	111-132	BOLT - 5/16" - 18 x 3/4" carriage	UAR
40	C42056	SCREW - 5/16" - 18 x 5/8" black	UAR
41	182-573	SCREW - #10-24 x 1/2"	4
41	C39403	SCREW - #12 x 1/2"	4
42	192-19	LOCKWASHER - 1/4"	8
43	C34117	NUT - #10 - 24 flange lock	2

INDEX

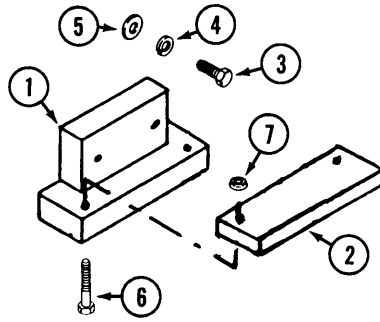

EARLY MODELS

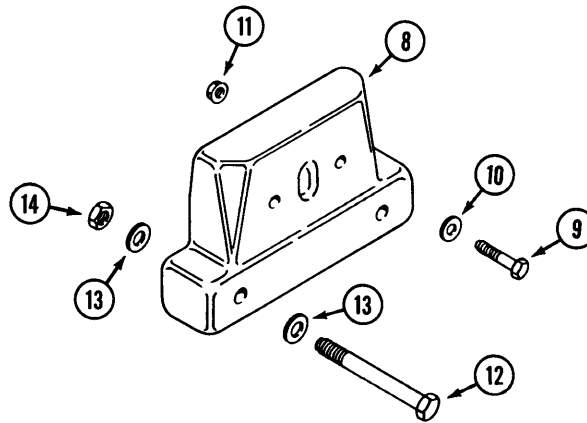

W48

INDEX

REAR WEIGHTS

REF.	PART NO.	DESCRIPTION	REQ'D
1	C37810	WEIGHT - tail	1
2	C37958	WEIGHT - tail 13 lb	2
3	113-103	BOLT- 5/16" - 18 x 1"	2
4	192-20	LOCKWASHER - 5/16"	2
5	195-103	WASHER - 5/16"	2
6	113-259	BOLT - 3/8" - 16 x 4-1/2"	2
7	131-1352	NUT - 3/8" - 16 flange lock	2
8	NSS	WEIGHT - tail 48 lb. (order as W48 whole goods).....	2
9	113-213	BOLT - 3/8" - 16 x 2-1/4"	2
10	195-525	WASHER - 3/8"	2
11	131-1352	NUT - 3/8" - 16 flange lock	2
12	113-650	BOLT - 5/8" - 11 x 6-1/2"	2
13	195-541	WASHER - 5/8"	4
14	131-356	NUT - 5/8" lock	2

INDEX

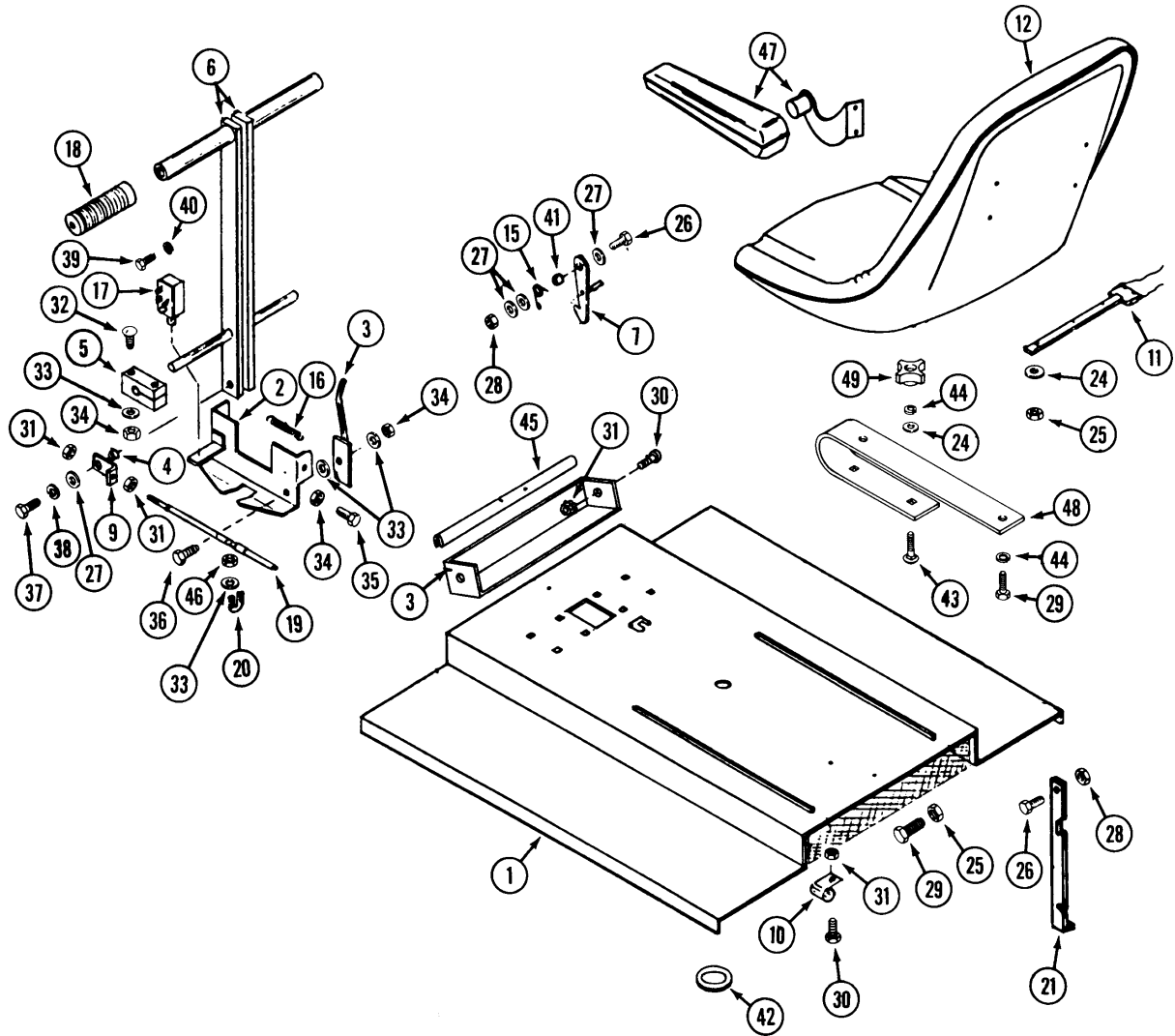

SEAT LID AND STEERING

REF.	PART NO.	DESCRIPTION	REQ'D
1	C44237	LID - seat.....	1
2	C37840	BRACKET - lever lock.....	1
3	C37841	LATCH - lever lock.....	1
4	C42895	BUSHING - (also order C42896)	2
5	C37842	BEARING - block	4
6	C44915	LEVER - steering	2
7	C44481	LATCH - seat lid.....	1
9	C42896	BRACKET - steering cable end	4
10	C32455	RETAINER - harness, seat lid	1
11	C45537	SWITCH - seat	1
12	C43202	SEAT	1
13	C37826	PLATE - lid filler	1
15	C37851	SPRING - latch, seat lid	1
16	C37837	SPRING - bracket, lever lock	1
17	C37521	SWITCH - safety	1
18	C37631	GRIP - handle	2
19	NSS	CABLE - steering (5020V) (see page 29)	2
19	C37705	CABLE - steering (5018CD).....	2
20	C37616	CLAMP - steering cable	UAR
21	C37852	PROP - seat lid	1
24	195-103	WASHER - 5/16"	8
25	131-69	NUT - 5/16".....	4
26	113-4	BOLT - 1/4" - 20 x 1"	2
27	195-520	WASHER - 1/4"	3
28	131-71	NUT - 1/4" - 20 lock.....	3
29	113-103	BOLT - 5/16" - 18 x 1"	6
30	182-528	SCREW - #10 - 32 x 1/2"	3
31	193-1000	NUT - #10 - 32	7
32	111-114	BOLT - 1/4" - 20 x 1-1/2" carriage.....	8
33	195-102	WASHER - 1/4"	10
34	131-71	NUT - 1/4" - 20 lock.....	11
35	113-3	BOLT - 1/4" - 20 x 3/4"	2
36	C42359	BOLT 1/4" - 20 x 2"	1
37	113-3	BOLT - 1/4" - 20 x 3/4"	2
38	192-19	LOCKWASHER - 1/4"	2
39	182-525	SCREW - #10 - 32 x 3/8"	1
40	192-18	LOCKWASHER - 3/16"	1
41	C44498	SPACER.....	1
42	C37787	GROMMET - 1/2" x 1"	UAR
42	C25165	GROMMET - 1" x 1-3/4"	UAR
43	111-204	BOLT - 5/16"- 18 x 1"	4
44	192-20	LOCKWASHER - 5/16"	8
45	C41956	TRIM - (23-1/2" piece, cut to length)	1
46	131-71	NUT - 1/4" - 20 lock.....	UAR
47	NSS	KIT - arm rest (optional) (order as machinery item BDS13)	
	C22947	TIE - nylon.....	1
48	C43137	SPRING - seat	2
49	C43438	KNOB - seat	4

INDEX

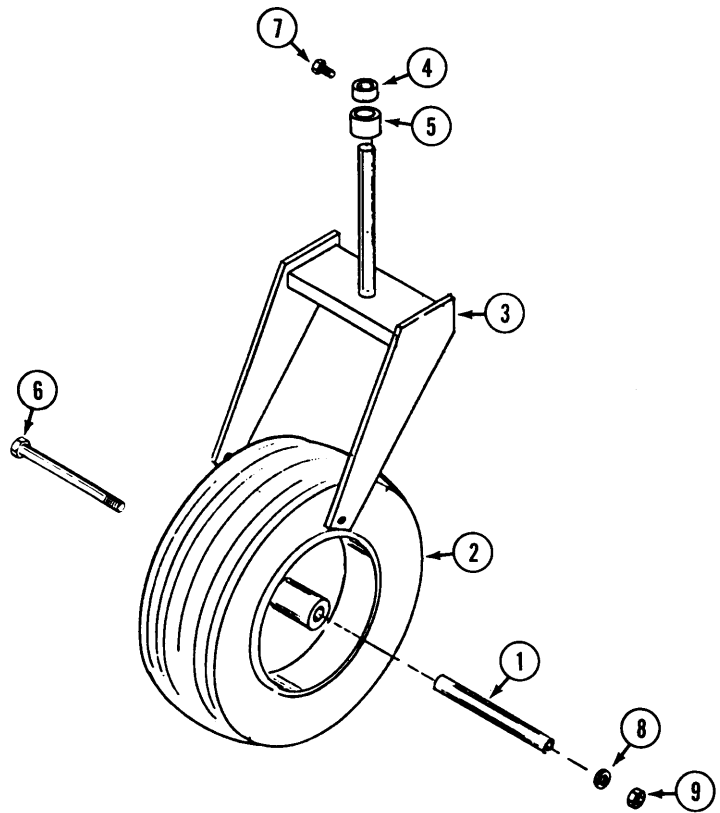

INDEX

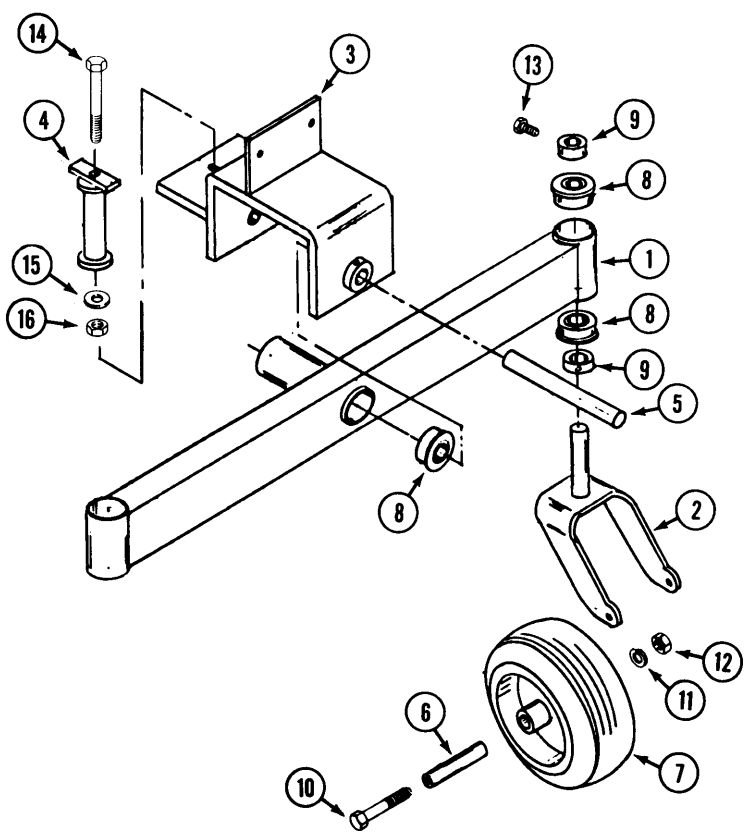

INDEX**SINGLE TAIL WHEEL**

REF.	PART NO.	DESCRIPTION	REQ'D
1	C37854	AXLE - wheel	1
2	C37855	WHEEL ASSEMBLY - tail	1
	C44499	BEARING - wheel.....	2
	C37857	TIRE - 16 x 6.50 - 8	1
	C37858	RIM - 8 (includes bearings)	1
3	C37859	FORK - tail wheel	1
4	C37860	COLLAR - set 1"	1
5	C37861	SPACER - tail wheel fork	1
6	113-452	BOLT - 1/2 - 13 x 9-1/2	1
7	85-58	SCREW - set 5/16" - 18 x 1/2" square head	1
8	192-23	LOCKWASHER - 1/2"	1
9	129-105	NUT - 1/2"- 13	1
	219-92	FITTING - grease 90° 1/4" - 28 self tap (caster pivot)	1

INDEX**DUAL TAIL WHEEL (DW10)**

1	C37863	AXLE - dual wheel.....	1
2	NSS	FORK - tail wheel (use C45645 and 113-448).....	2
3	C37865	BRACKET - mounting	1
4	C37866	TUBE - block	1
5	C38230	PIVOT - axle.....	1
6	C37915	AXLE - wheel	2
7	C37869	WHEEL ASSEMBLY	2
	C44499	BEARING - wheel	2
	C45636	TIRE - 13 x 5.00 - 6.....	2
	C45634	RIM.....	2
8	C37824	BEARING - 1"	6
9	C37860	COLLAR - set 1"	4
10	113-2419	BOLT - 1/2" - 13 x 6-1/2"	2
11	192-23	LOCKWASHER - 1/2"	2
12	129-105	NUT - 1/2" - 13	2
13	C37756	SCREW - set 5/16" - 18 x 1/2" square head	4
	219-20	FITTING - grease 1/4" - 28 self tap (castor pivot)	UAR
14	C38055	BOLT - 1/2" - 13 x 8-1/2'	1
15	195-106	WASHER - 1/2"	UAR
16	131-70	NUT - 1/2" - 13 lock.....	1

DTW10 DUAL TAIL WHEEL

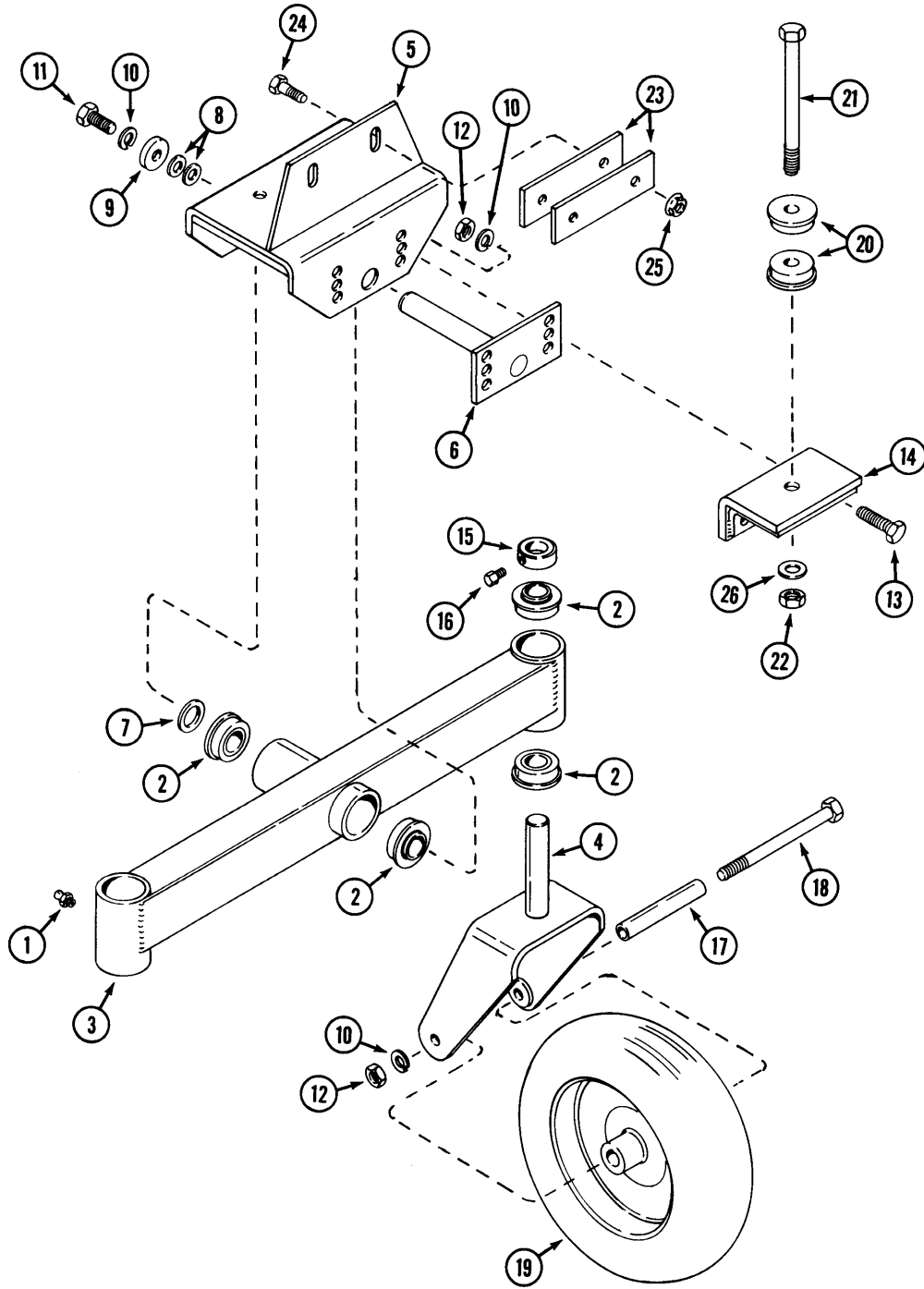

INDEX

DTW10 DUAL TAIL WHEEL

REF.	PART NO.	DESCRIPTION	REQ'D
1	219-20	FITTING - lubrication 1/4" - 28	3
2	C37824	BEARING - ball 1"	6
3	C45610	AXLE - dual wheel.....	1
4	C45645	FORK - wheel.....	2
5	C45618	MOUNT - axle	1
6	C45689	ROD - axle pivot.....	1
7	C14919	WASHER - 1" x 1-3/4"	UAR
8	195-2067	WASHER - 1/2" x 1"	UAR
9	C45841	WASHER - 1/2" x 1-3/8"	1
10	192-23	LOCKWASHER - 1/2"	5
11	113-417	BOLT - 1/2" - 13 x 1-1/4"	1
12	129-105	NUT - 1/2" - 13	4
13	113-412	BOLT - 1/2" - 13 x 1-3/4"	2
14	C45708	MOUNT - axle, front extension	1
15	C37860	COLLAR - set 1"	2
16	85-58	SCREW - set 5/16" - 18 x 1/2" square head	1
17	C37915	TUBE-axle	2
18	113-448	BOLT - 1/2 - 13 x 7	2
19	C37869	WHEEL ASSEMBLY	2
	C44499	BEARING - wheel	2
	C45636	TIRE - 13 x 5.00 - 6	1
	C45634	RIM	1
20	C45711	BUSHING - tail wheel hub.....	2
21	113-646	BOLT - 5/8" - 11 x 7-1/2"	UAR
21	113-2606	BOLT - 5/8" - 11 x 11"	UAR
22	131-356	NUT - 5/8" - 11	1
23	C45746	PLATE - stiffener	2
24	113-208	BOLT - 3/8" - 16 x 1-1/4"	2
25	131-1352	NUT - 3/8" - 16 flange lock	2
26	195-541	WASHER - 5/8" x 1-1/2"	1

INDEX

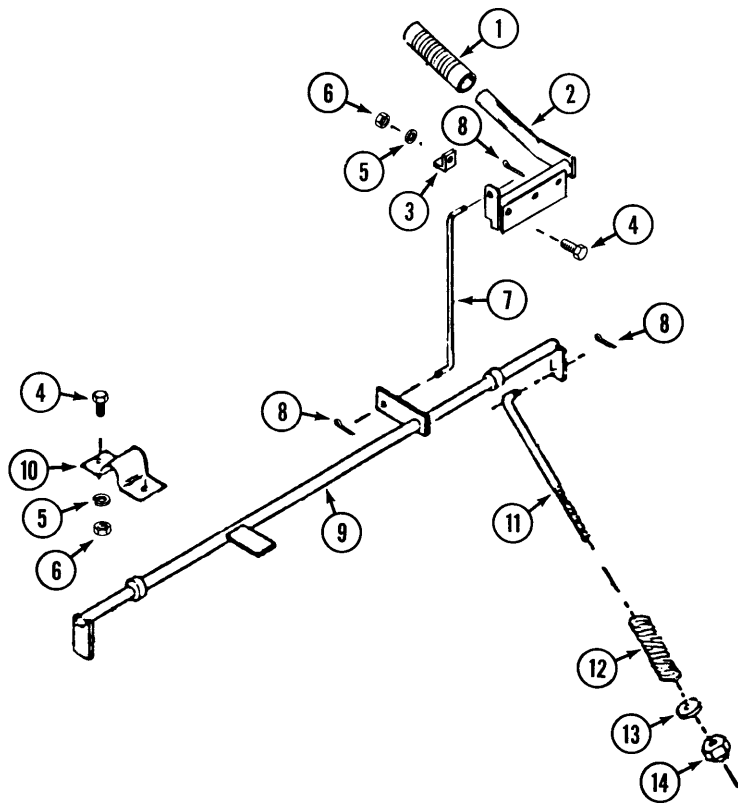

INDEX

PARKING BRAKE
(also see drive assembly)

REF.	PART NO.	DESCRIPTION	REQ'D
1	C37631	GRIP - handle	1
2	C37604	HANDLE - brake	1
3	C37630	BRACKET - stop (5020V)	1
4	113-3	BOLT - 1/4" - 20 x 3/4"	4
5	192-19	LOCKWASHER - 1/4'	4
6	129-101	NUT - 1/4" -20	4
7	C37606	ROD - brake (5018CD)	1
7	C37822	ROD - brake (5020V)	1
8	132-332	PIN - cotter 3/32 x 1"	2
9	C37985	ROD - cross, brake (5018CD) (5020V brake rod not replaceable).....	1
10	C37607	BEARING - cross rod (5018CD)	2
11	C37986	ROD - caliper (5018CD) (5020V see drive assembly)	2
12	C37987	SPRING - compression (5018CD) (5020V see drive assembly)	2
13	195-102	WASHER - 1/4	2
14	131-71	NUT - lock 1/4 - 20	2

DRIVE ASSEMBLY RH.
(5020V)

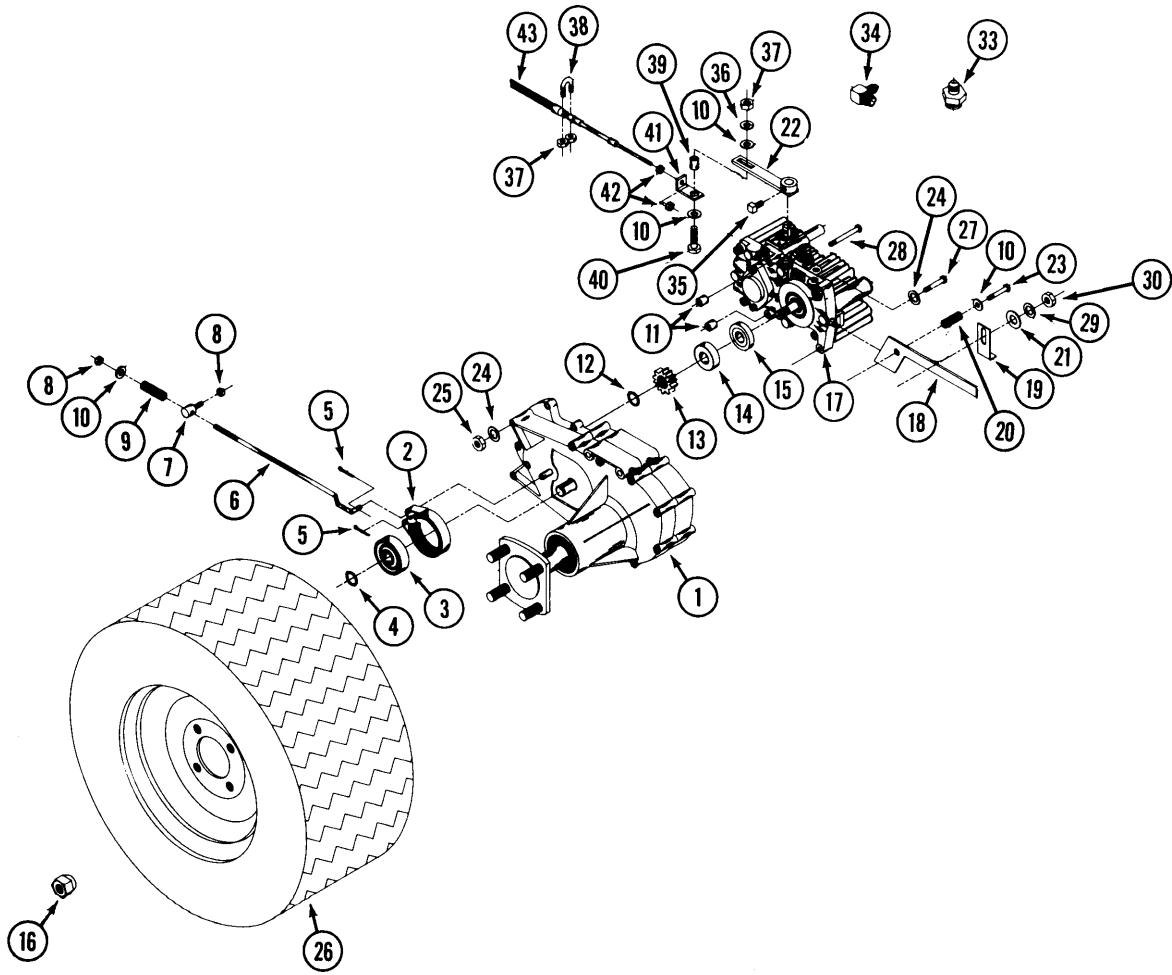

**DRIVE ASSEMBLY RH.
(5020V)**

REF.	PART NO.	DESCRIPTION	REQ'D
1	C46087	TRANSMISSION - ZT (see page 45 for parts)	1
2	C37730	BAND - brake	1
3	C37731	DRUM - brake	1
4	C37732	RING - snap	1
5	132-332	PIN - cotter 1/8" x 1"	2
6	C37733	ROD - brake	1
7	C37724	COLLAR - brake rod	1
8	131-71	NUT - lock 1/4" - 20	2
9	C37725	SPRING	1
10	195-102	WASHER - 1/4"	5
11	C37736	SPACER	2
12	C37737	RING - snap	1
13	C37738	GEAR	1
14	C37739	BEARING	1
15	C37740	SPACER	1
16	C37657	NUT - lug 1/2" - 20	4
17	C45399	PUMP - hydro R.H. (see page 47)	1
18	C45166	LEVER - transmission dump	1
19	C37743	BRACKET - dump lever stop	1
20	C37744	SPRING - compression	1
21	195-104	WASHER - 3/8"	1
22	NSS	ARM - transmission (see page 29)	1
23	C37747	BOLT - dump valve	1
24	192-21	LOCKWASHER - 5/16"	4
25	129-103	NUT - 5/16" - 18	2
26	C37763	WHEEL ASSEMBLY	1
	C37652	TIRE - 18 x 9.50 - 8	1
	C37656	RIM - wheel	1
27	113-120	BOLT - 5/16" - 18 x 1-3/4"	2
28	113-134	BOLT - 5/16" - 18 x 7-1/2"	2
29	192-21	LOCKWASHER - 3/8"	1
30	129-103	NUT - 3/8" - 16	1
33	C37754	ADAPTER -	1
34	218-5278	ADAPTER - 90	1
35	C37756	SCREW - set 5/16" - 18 x 1/2" square head	1
36	192-19	LOCKWASHER - 1/4"	1
37	131-1102	NUT - 1/4" - 20	3
38	C37616	CLAMP - cable	1
39	C42895	BUSHING - cable	1
40	113-4	BOLT - 1/4" - 20 x 1"	1
41	C42896	BRACKET - cable end	1
42	193-1000	NUT - lock #10-32	4
43	NSS	CABLE - steering 58" (see page 29)	1

NOTE: See page 29 for steering cable kit.

DRIVE ASSEMBLY L.H.
(5020V)

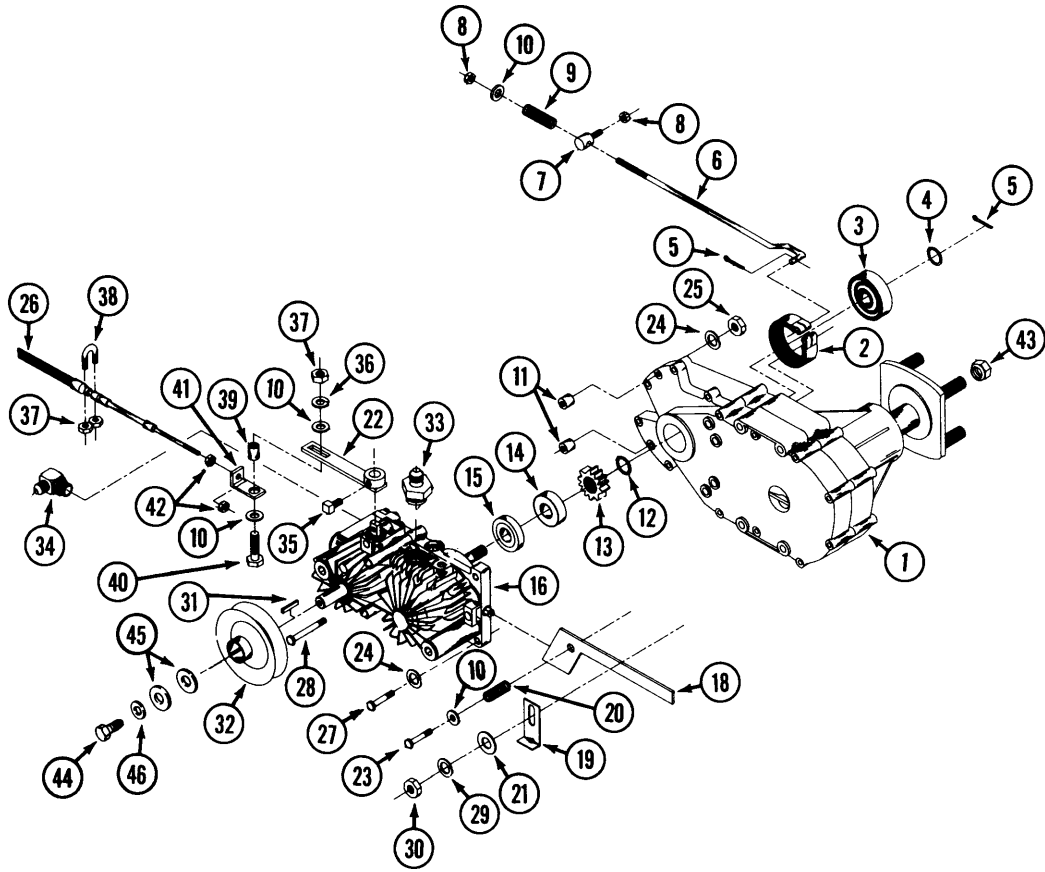

DRIVE ASSEMBLY L.H. (5020V)

REF.	PART NO.	DESCRIPTION	REQ'D
1	C46087	TRANSMISSION - ZT (see page 45 for parts)	1
2	C37730	BAND - brake	1
3	C37731	DRUM - brake	1
4	C37732	RING - snap	1
5	132-332	PIN - cotter 1/8" x 1"	2
6	C37733	ROD - brake	1
7	C37724	COLLAR - rod	1
8	131-71	NUT - lock 1/4" - 20	2
9	C37725	SPRING	1
10	195-102	WASHER - 1/4"	5
11	C37736	SPACER	2
12	C37737	RING - snap	1
13	C37738	GEAR	1
14	C37739	BEARING	1
15	C37740	SPACER	1
16	C45398	PUMP - hydro L.H. (see page 47)	1
18	C45165	LEVER - transmission dump	1
19	C37743	BRACKET - dump lever stop	1
20	C37744	SPRING - compression	1
21	195-103	WASHER - 3/8"	1
22	NSS	ARM - transmission (see page 29)	1
23	C37747	BOLT - dump lever	1
24	192-21	LOCKWASHER - 5/16"	4
25	129-103	NUT - 5/16" - 18	2
26	NSS	CABLE - steering 58" (see page 29)	1
27	113-120	BOLT - 5/16" - 18 x 1-3/4"	2
28	113-134	BOLT - 5/16" - 18 x 7-1/2"	2
29	192-21	LOCKWASHER - 3/8"	1
30	129-103	NUT - 3/8" - 16	1
33	C37754	FITTING - male adapter	1
34	218-5278	FITTING - male adaptor 90°	1
35	C37756	SCREW - set 5/16" - 18 x 1/2" square head	1
36	192-19	LOCKWASHER - 1/4"	1
37	131-1102	NUT - 1/4" - 20	3
38	C37616	CLAMP - cable	1
39	C42895	BUSHING - cable	1
40	113-4	BOLT - 1/4" - 20 x 1"	1
41	C42896	BRACKET - cable end	1
42	193-1000	NUT - lock #10-32	4
	C37763	WHEEL ASSEMBLY - not shown	1
	C37652	TIRE - 18 x 9.50-8	1
	C37656	RIM - wheel	1
43	C37657	NUT - lug 1/2"-20	4

NOTE: [See page 29 for steering cable kit.](#)

INDEX

C43293 STEERING CABLE KIT (5020V)

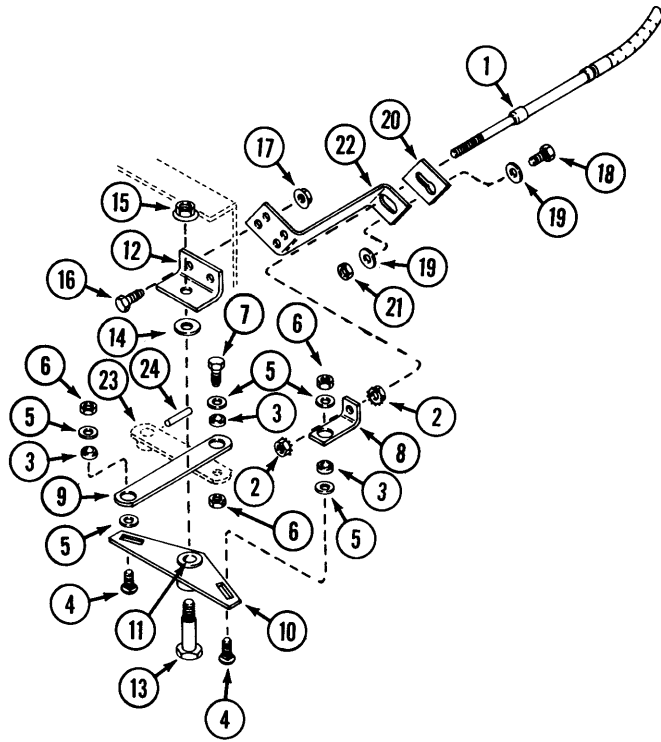

INDEX

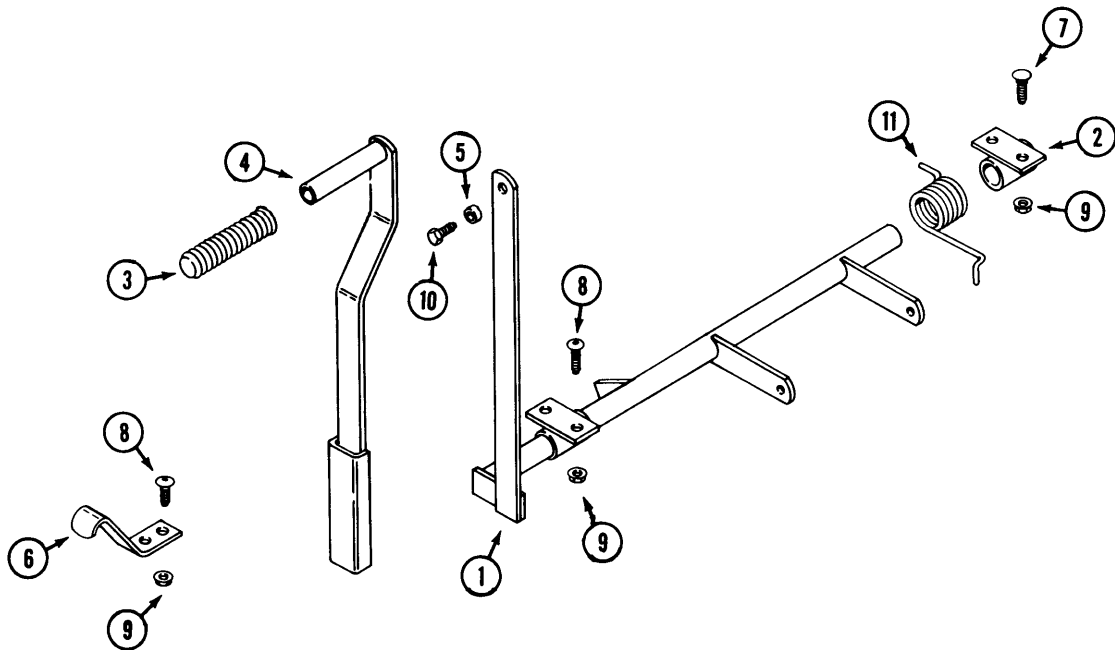

INDEX**C43293 STEERING CABLE KIT (5020V)
(includes cables and hardware for both sides)**

REF.	PART NO.	DESCRIPTION	REQ'D
1	C42894	CABLE - steering 46"	2
2	193-1000	NUT - #10 - 32	8
3	C42895	BUSHING - steering cable	8
4	111-111	BOLT - 1/4" - 20 x 1" carriage	4
5	195-102	WASHER - 1/4"	10
6	131-71	NUT - 1/4" - 20	6
7	113-4	BOLT - 1/4" - 20x 1"	2
8	C42896	BRACKET - steering cable end	4
9	C42897	LINK - control cable.....	2
10	C42898	BELLCRANK.....	2
11	C16714	BUSHING.....	1
12	C42901	BRACKET - bellcrank mounting.....	2
13	C16745	BOLT - shoulder	2
14	195-533	WASHER - 1/2"	2
15	131-1352	NUT - 3/8" - 16 flange lock	2
16	113-103	BOLT - 5/16" - 18 x 1"	4
17	131-911	NUT - 5/16" - 18	4
18	113-4	BOLT - 1/4" - 20 x 1"	2
19	195-102	WASHER - 1/4"	4
20	C42903	PLATE - cable mounting	2
21	131-71	NUT - 1/4" - 20 lock.....	2
22	C42902	BRACKET - cable mounting.....	2
23	C42904	ARM - transmission.....	2
24	C34173	PIN - spring	2

INDEX**LIFT LEVER**

1	C44942	LEVER - lift.....	1
2	C44948	PIVOT - lift.....	1
3	C37631	GRIP - handle	1
4	C44949	EXTENSION - lift lever, upper.....	1
5	C42895	BUSHING	1
6	C44952	BRACKET - lever lock down	1
7	111-132	BOLT - carriage 5/16" - 18 x 3/4"	4
8	C42056	SCREW - 5/16" - 18 x 5/8" allen head	2
8	C44959	SCREW - 5/16" - 18 x 3/4"	4
9	131-911	NUT - 5/16" - 18 flange lock	8
10	113-1	BOLT - 1/4" - 20 x 1/2"	1
11	C45120	SPRING - torsion	1

TRANSMISSION AND DRIVE CHAINS
(5018CD)

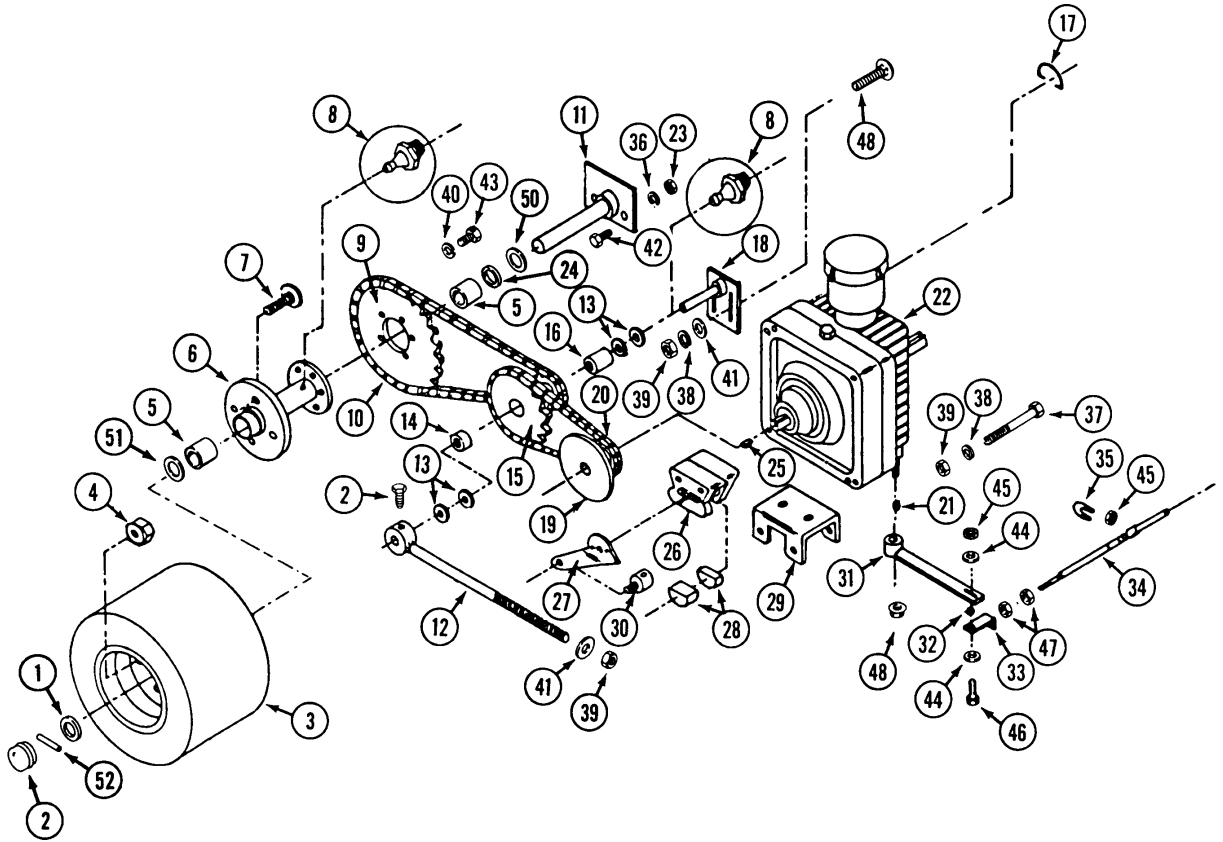

INDEX

**TRANSMISSION AND DRIVE CHAINS
(5018CD)**

REF.	PART NO.	DESCRIPTION	REQ'D
1	C46058	SPACER - hub.....	2
2	C28317	CAP - hub.....	2
3	C45887	WHEEL ASSEMBLY - drive.....	2
	C37652	TIRE - 16 x 7.50 - 8.....	1
	C45888	RIM - wheel.....	1
4	C37657	NUT - lug 1/2"-20.....	8
5	C45928	BEARING - wheel hub.....	4
6	C45933	HUB - wheel.....	1
7	C37661	BOLT - lug 1/2" - 20 x 1-1/4".....	4
8	219-20	FITTING - grease 1/4" - 28 self tapping.....	1
9	C37994	SPROCKET - final drive.....	1
10	C45927	CHAIN - final drive.....	1
11	C45929	AXLE - drive wheel.....	1
12	C37998	COLLAR - support.....	2
13	C37999	WASHER - 3/4" 10 gage.....	8
14	C38000	BEARING - idler sprocket 1/2".....	2
15	C38002	SPROCKET - idler (includes bearings).....	1
16	C38003	BEARING - idler sprocket 3/4".....	2
17	C38004	CLIP - transmission dump valve.....	2
18	C38005	SHAFT - idler sprocket.....	2
19	C38006	SPROCKET - transmission (includes brake disc).....	2
20	C44083	CHAIN - primary drive.....	2
21	126-6	KEY - 1/8" x 3/8" Woodruff.....	2
22	C38008	TRANSMISSION L.H. (shown) (CW).....	1
22	C38009	TRANSMISSION - R.H. (CCW).....	1
	C38010	DIAPHRAGM - transmission.....	1
	C38011	KIT - seal.....	1
	C38012	KIT - reservoir, transmission.....	1
23	129-105	NUT - 1/2" - 13.....	4
24	C32891	SEAL - oil.....	2
25	126-9	KEY - woodruff 1/8" x 1/2".....	2
	C37626	BRAKE ASSEMBLY - L.H.....	1
	C37625	BRAKE ASSEMBLY - R.H.....	1
26	NSS	CALIPER - brake.....	1
27	C38016	LEVER - caliper L.H.....	1
27	C38017	LEVER - caliper R.H.....	1
28	C37627	PAD - brake (set).....	1
29	C38018	BRACKET - caliper.....	1
30	C37724	COLLAR - caliper rod.....	1
31	C37698	ARM - transmission L.H.....	1
31	C37699	ARM - transmission R.H.....	1
32	C42895	BUSHING - cable end.....	2
33	C42896	END - steering cable.....	2
34	C37705	CABLE - steering.....	2
35	C37616	CLAMP - steering cable.....	2
36	192-23	LOCKWASHER - 1/2".....	4
37	113-241	BOLT - 3/8" - 16 x 3".....	8
38	192-21	LOCKWASHER - 3/8".....	8
39	129-103	NUT - 3/8" - 16.....	8
40	192-20	LOCKWASHER - 5/16".....	5
41	195-104	WASHER - 3/8".....	4
42	113-412	BOLT - 1/2" - 13 x 1-3/4".....	4
43	113-103	BOLT - 5/16" 18 x 1".....	5
44	195-102	WASHER - 1/4".....	4
45	131-71	NUT - 1/4" - 20 lock.....	6
46	113-4	BOLT - 1/4" - 201".....	2
47	193-1000	NUT - #10 - 32 lock.....	4
48	111-366	BOLT - carriage 3/8" - 16 x 1-1/4".....	4
49	131-1352	NUT - 3/8" - 16 flange lock.....	2
50	C15557	SHIM - .050".....	2
51	C15556	SHIM - .010".....	UAR
52	138-138	PIN - roll 1/4" x 1-1/2".....	1

INDEX

CROSS SHAFT (TRANSMISSION) (5018CD)

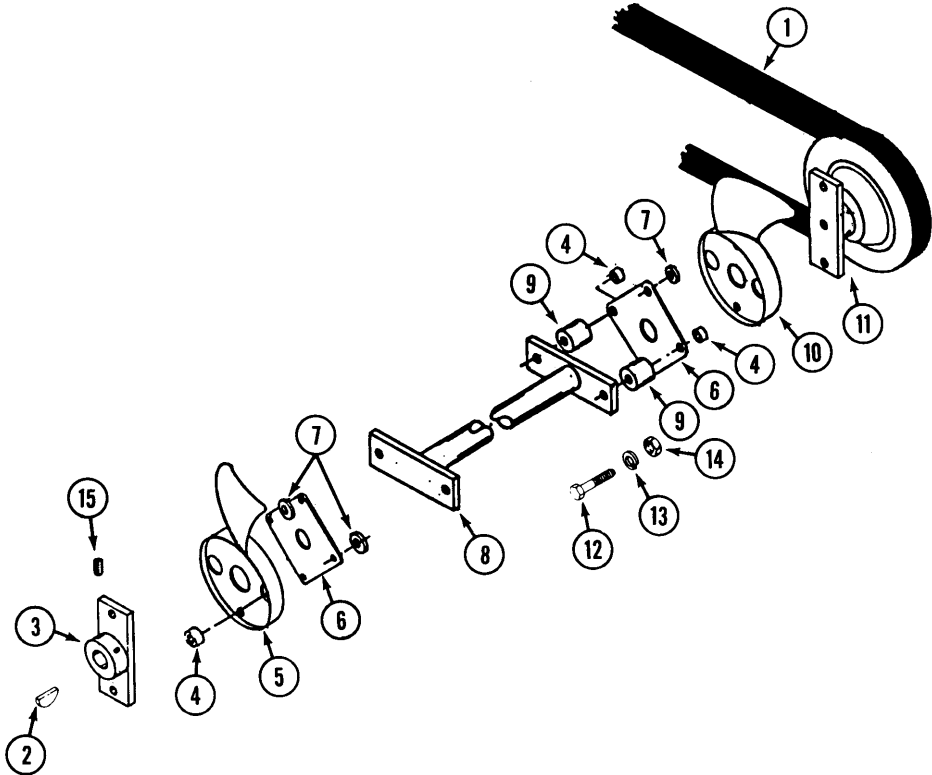

INDEX

DRIVE PULLEY AND CROSS SHAFT (TRANSMISSION) (5020V)

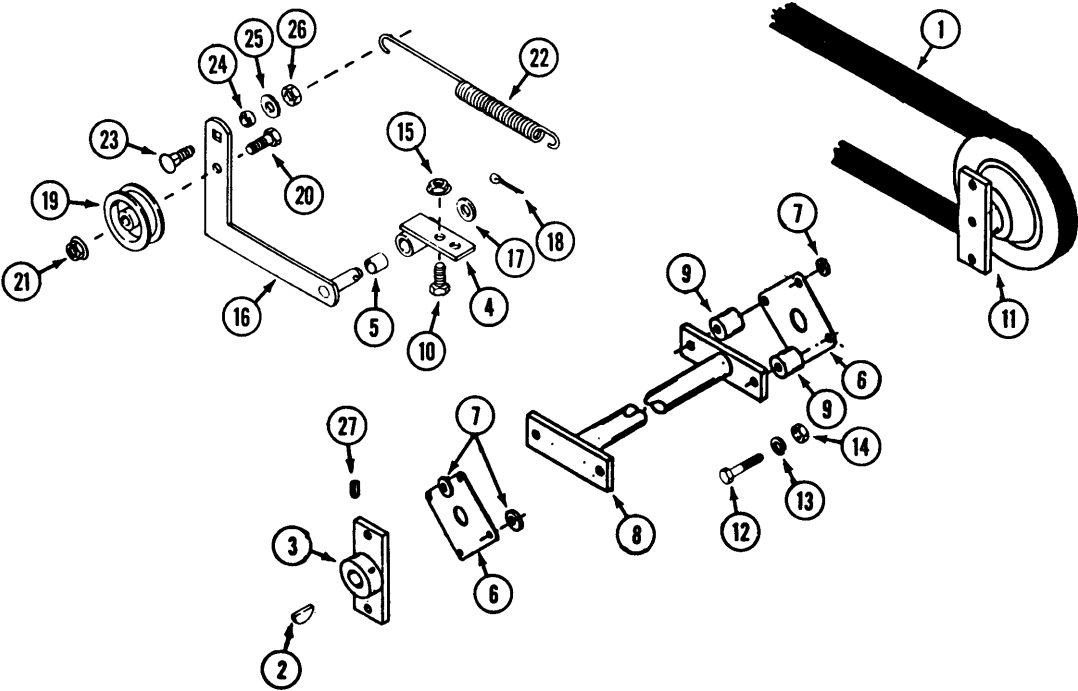

INDEX**CROSS SHAFT (TRANSMISSION)
(5018CD)**

REF.	PART NO.	DESCRIPTION	REQ'D
1	C37995	BELT - transmission drive	1
2	126-9	KEY - woodruff 1/8" x 1/2"	2
3	C37694	HUB - drive plate	1
4	C37702	SPACER - bolt	4
5	C38014	FAN - CCW	1
6	C37700	PLATE - drive	2
7	C37704	WASHER - 1/4" 10 gage	6
8	C38015	SHAFT - cross	1
9	C37703	SPACER	2
10	C38019	FAN - CW	1
11	C37695	PULLEY - drive (includes drive plate)	1
12	113-110	BOLT - 5/16 - 18 x 2-1/4"	UAR
12	113-104	BOLT - 5/16" - 18 x 1-1/4"	UAR
12	113-103	BOLT - 5/16" - 18 x 1"	UAR
13	192-20	LOCKWASHER - 5/16"	8
14	129-102	NUT - 5/16" - 18	8
15	84-45	SCREW - set 1/4" - 28 x 3/8"	2

INDEX**DRIVE PULLEY AND CROSS SHAFT (TRANSMISSION)
(5020V)**

1	C26437	BELT - transmission drive	1
2	C37725	KEY - 5 x 5 x 25 mm	2
3	C46092	HUB - drive plate	1
4	C46100	MOUNT - idler	1
5	C16714	BUSHING	1
6	C37700	PLATE - drive	2
7	C37704	WASHER - 5/16" 10 ga	4
7	195-102	WASHER - 5/16"	UAR
8	C46097	SHAFT - cross	1
9	C37703	SPACER	2
10	113-207	BOLT - 3/8" - 16 x 1"	2
11	C46088	PULLEY - drive (includes drive plate)	1
12	113-103	BOLT - 5/16" - 18 x 1"	UAR
12	113-121	BOLT - 5/16" - 18 x 2	UAR
13	192-20	LOCKWASHER - 5/16"	8
14	129-102	NUT - 5/16" - 18	8
15	131 -938	NUT - 3/8" - 16 flange lock	2
16	C46102	ARM - idler	1
17	195-2067	WASHER - 1/2" x 7/8"	1
18	132-318	PIN - cotter	1
19	C15672	PULLEY - idler	1
20	113-209	BOLT - 3/8" - 16 x 1-1/2"	1
21	131-1352	NUT - 3/8" - 16 flange lock	1
22	C46105	SPRING - tension	1
23	111-342	BOLT - carriage 3/8" - 16 x 1"	1
24	C14768	SPACER - 3/8" x 1/2"	1
25	195-103	WASHER - 3/8"	1
26	131-1181	NUT - 3/8" - 16 lock	1
27	83-55	SETSCREW - 5/16" - 18 x 5/16"	2

HYDRAULIC SYSTEM (5020V)

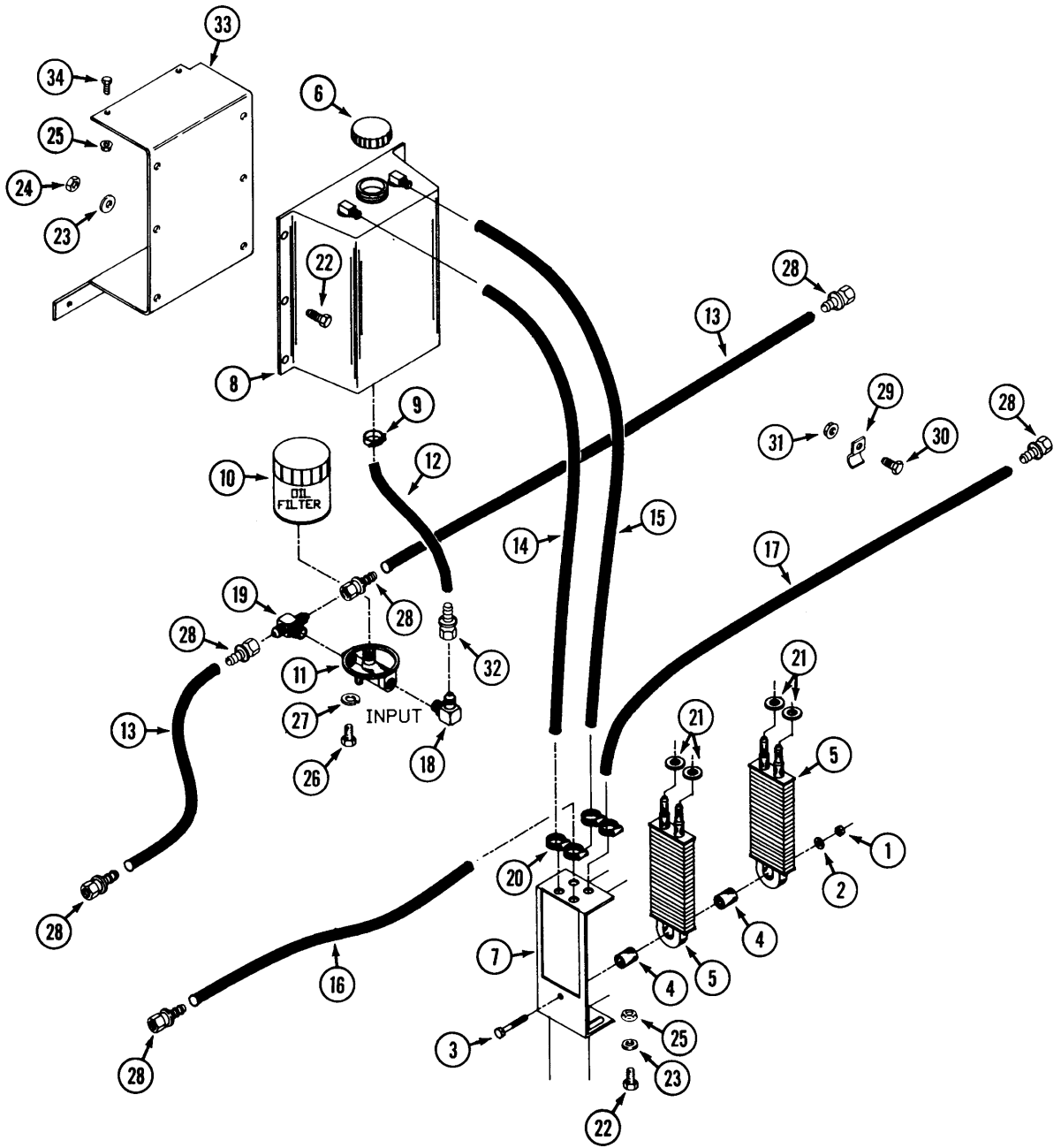

INDEX

**HYDRAULIC SYSTEM
(5020V)**

REF.	PART NO.	DESCRIPTION	REQ'D
1	131-69	NUT - lock 5/16"	1
2	195-103	WASHER - 5/16"	1
3	113-119	BOLT - 5/16" - 18 x 2-3/4'	1
4	C45495	BUSHING - rubber	2
5	C37769	COOLER - oil	2
6	C37639	CAP - oil tank	1
7	C37772	MOUNT - oil cooler	1
8	C37778	TANK - oil	1
9	214-254	CLAMP - hose 5/8"	2
10	C37637	FILTER - oil	1
11	C37636	HEAD - oil filter	1
12	C42785	HOSE - 5/8" x 11" (12" cut to length)	1
13	C42784	HOSE - hydraulic 3/8" x 13" (48 cut to length)	1
14	C42784	HOSE - hydraulic 3/8" x 29" (48 cut to length)	1
15	C42784	HOSE - hydraulic 3/8" x 27" (48 cut to length)	1
16	C42784	HOSE - hydraulic 3/8" x 38" (48 cut to length)	1
17	C42784	HOSE - hydraulic 3/8" x 24" (48 cut to length)	1
18	218-5280	FITTING - male 90° adapter	1
19	218-5182	FITTING - male tee adapter	1
20	214-274	CLAMP - hose 3/8"	4
21	C37787	GROMMET- 1/2" ID x 1" OD	4
22	113-3	BOLT - 1/4" - 20 x 3/4"	6
23	195-102	WASHER - 1/4"	8
24	131-1102	NUT - 1/4" - 20 lock	4
25	131-934	NUT - 1/4" - 20 flange lock	2
26	C34808	BOLT - 1/4" - 20 x 3/4' self-tap	2
27	192-19	LOCKWASHER - 1/4"	2
28	C41986	FITTING - 3/8" hose barb x 3/8" FM JIC	6
29	C32455	CLIP - "J"	1
30	113-102	BOLT - 5/16" x 18 x 3/4"	1
31	131-911	NUT - 5/16" - 18 flange lock	1
32	C41978	FITTING - 5/8" hose barb x 1/2" FM JIC	1
33	C46083	MOUNT - oil tank	1
34	113-3	BOLT - 1/4" - 20 x 1/2"	4

ELECTRICAL SYSTEM

REF.	PART NO.	DESCRIPTION	REQ'D
	C45535	HARNESS - wire, main	1
1	C45539	HARNESS - wire, alternator and magneto.....	1
2	C37505	BREAKER - circuit, 10 amp	1
3	C32178	HEADLIGHT.....	2
	C22573	LENS - headlight.....	1
	C37508	BULB - headlight.....	1
	C37509	RECEPTICAL.....	1
	C14304	GASKET - headlight.....	1
4	C31937	SWITCH - PTO (also use C31619 Cap)	1
	C44469	NUT - 1/2" - 27 (Black) PTO switch retaining.....	2
5	C43044	SWITCH - headlight	1
6	C30267	SWITCH - ignition	1
	C32407	KEY - ignition	1
	C32397	CAP - nut, ignition switch	1
	193-63	LOCKWASHER - 5/8"	1
	C32396	NUT - 5/8" - 32 ignition switch.....	1
7	C29413	AMMETER	1
8	C45917	METER - hour	1
9	C45536	LIGHT - oil.....	1
10	C45537	SWITCH - seat	1
11	C37521	SWITCH - safety	2
	182-525	SCREW - #10 - 32 x 3/8" (safety switch mount)	1
	192-18	LOCKWASHER - 3/16 (safety switch mount)	1
	193-1000	NUT - #10 - 32 Lock (safety switch mount).....	2
	182-528	SCREW - #10 - 32 x 1/2 (safety switch mount)	2
12	C41010	BATTERY - 12 volt.....	1
13	C44261	WIRE - starter	1
14	C37511	CLUTCH - PTO	1
15	C37528	CABLE - ground	1
16	C44075	WIRE - headlight	1
17	C33024	SOLENOID - start	1
	113-3	BOLT - 1/4 - 20 x 3/4" (solenoid mounting).....	2
	131-934	NUT - 1/4" - 20 (solenoid mounting)	2
	192-19	LOCKWASHER - 1/4 (solenoid studs).....	2
	129-101	NUT - 1/4" - 20 (solenoid studs).....	2
18	C37523	CABLE - battery positive to solenoid	1
19	C37531	SWITCH - oil light.....	1
20	C41643	WIRE - ground	1
21	C42240	HARNESS - oil pressure switch.....	1
22	C31947	KIT - fuse holder.....	1
23	C30260	FUSE - 30 amp	1

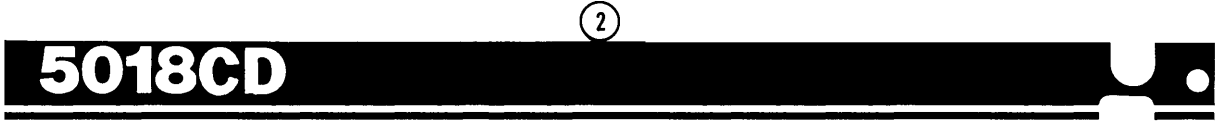

1 **INGERSOLL**

6 **CAUTION**
THIS MACHINE HAS AN IGNITION INTER LOCK SAFETY SYSTEM. ALL CONTROLS MUST BE IN NEUTRAL BEFORE THE ENGINE WILL START.

9 **DANGER**
ENGINES PRODUCE CARBON MONOXIDE, WHICH IS AN ODORLESS, DEADLY POISON. DO NOT OPERATE IN AN ENCLOSED AREA.

Lubrication reference guide

10

FRONT WHEEL AXLE BEARINGS	Every 2 hrs
FRONT WHEEL CHAIN BEARINGS	Every 2 hrs
FRONT WHEEL BEARINGS	Every 2 hrs
FRONT WHEEL FORK BEARINGS	Every 2 hrs
FRONT WHEEL AXLE BEARINGS	Every 2 hrs

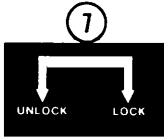

11 **CAUTION!** TRANSMISSION COOLER MUST BE KEPT CLEAN
▶▶ SEE OPERATOR'S MANUAL ◀◀

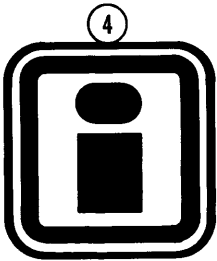

5 **OPERATION OF CONTROLS**
CONTROL THE SPEED THROUGH THE USE OF TRANSMISSION CONTROL ONLY.

CAUTION! READ OPERATING MANUAL BEFORE OPERATING THIS MACHINE.

FORWARD	NEUTRAL	REVERSE
---------	---------	---------

12 **WARNING**
READ OPERATOR'S MANUALS. KNOW LOCATION & FUNCTION OF ALL CONTROLS. KEEP ALL GUARDS, SHIELDS & SAFETY SWITCHES IN PLACE & WORKING. CLEAN WORKING AREA OF THINGS THAT COULD BE THROWN BY THE BLADES. DO NOT BROW WHER CHILDREN OR OTHERS ARE AROUND. LOOK DOWN & BEHIND BEFORE AND WHILE BACKING UP. GO UP AND DOWN SLOPES, NOT ACROSS. IF MACHINE STOPS GOING UPHILL, STOP BLADES AND BACK DOWN SLOWLY. AVOID SUDDEN TURNS. FAILURE TO OBSERVE THESE PRECAUTIONS COULD RESULT IN SERIOUS INJURY OR DEATH.

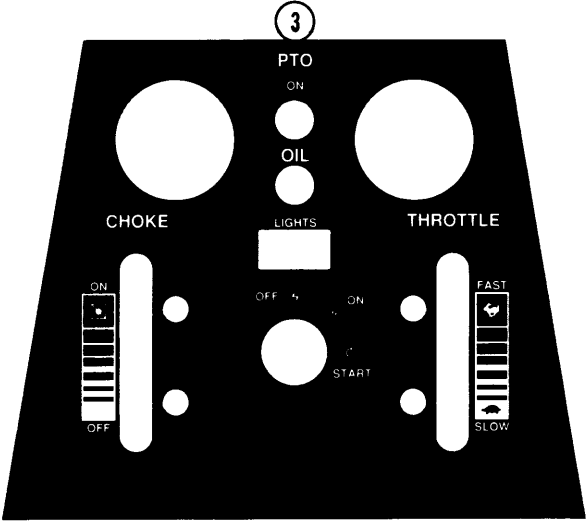

INDEX

DECALS

REF.	PART NO.	DESCRIPTION	REQ'D
1	C39527	DECAL - front side R.H. (shown)	1
1	C39528	DECAL - front side L.H.....	1
2	C46060	DECAL - rear side LH. (5018CD).....	1
2	C46061	DECAL - rear side R.H. (5018CD) shown.....	1
3	C40954	DECAL - instrument panel	1
4	C37464	MEDALLION - "Ingersoll"	1
5	C37495	DECAL - operation	1
6	C37496	DECAL - caution interlock	1
7	C37502	DECAL - unlock/lock	1
8	C37498	DECAL - run/park.....	1
9	C37500	DECAL - danger carbon monoxide	1
10	C38807	DECAL - lubrication.....	1
11	C37504	DECAL - clean cooler.....	1
12	C44340	DECAL - "WARNING"	1
13	C46068	DECAL - rear side LH. (5020V)	1
13	C46069	DECAL - rear side R.H. (5020V) shown	1

INDEX

Power Lift

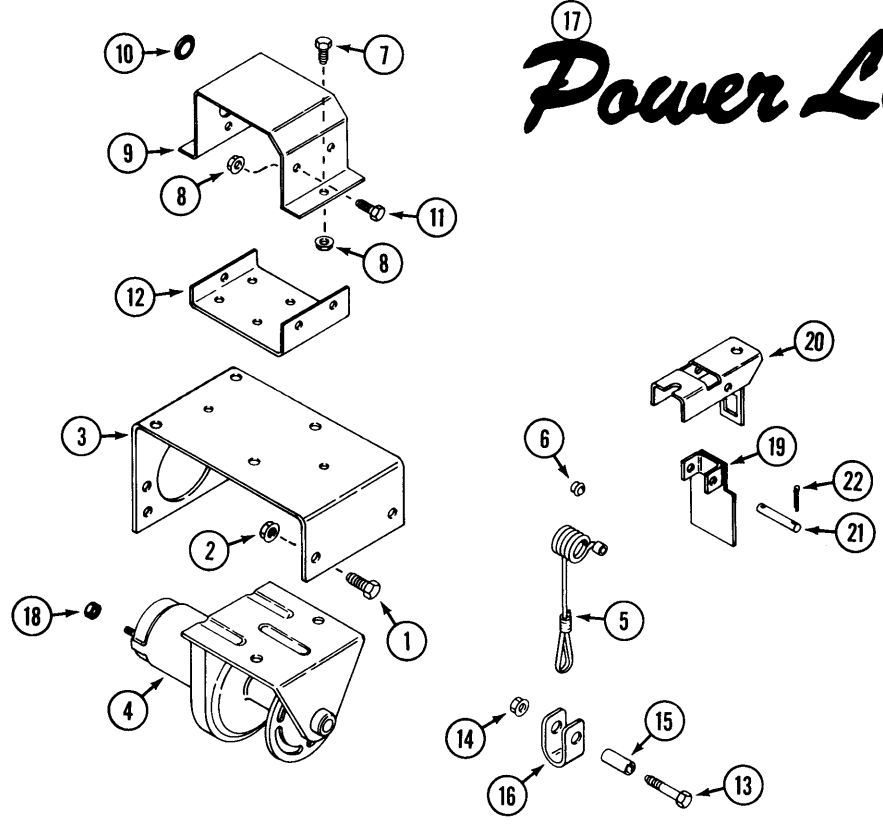

INDEX

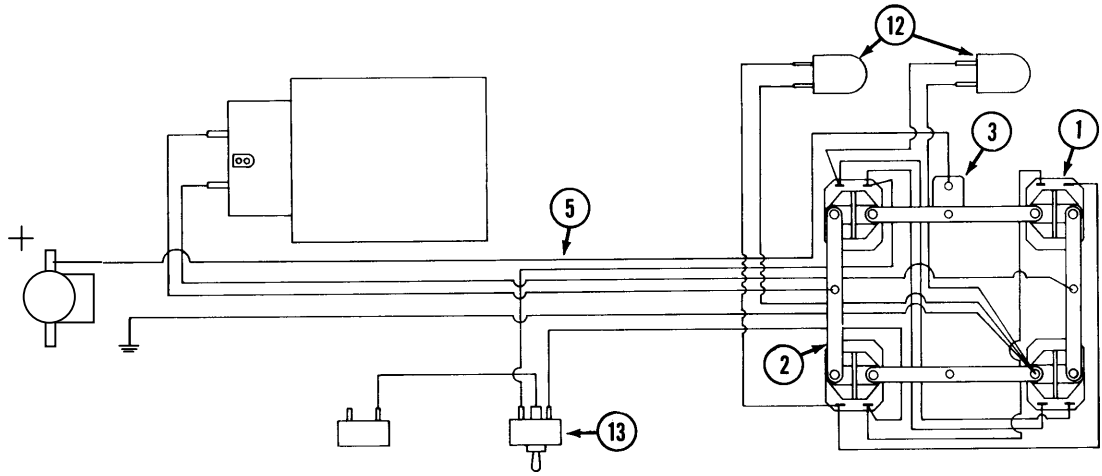
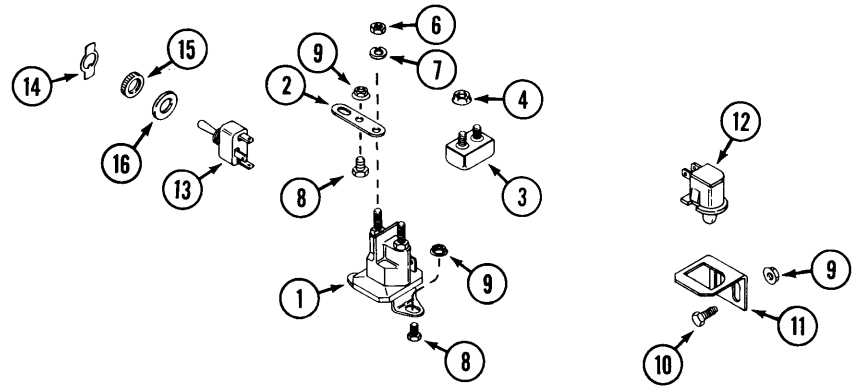

INDEX**ELECTRIC DECK LIFT
WINCH STYLE**

REF.	PART NO.	DESCRIPTION	REQ'D
1	113-207	BOLT - 3/8" - 16 x 1"	6
1	C44489	SCREW - 3/8" - 16 x 1" socket head.....	2
2	131-938	NUT - 3/8" - 16 flange lock	8
3	C43967	MOUNT - winch.....	1
4	NSS	WINCH - deck lift (order complete kit from whole goods).....	1
5	C43375	CABLE.....	1
6	C43992	PIN - cable keeper	1
7	113-3	BOLT - 1/4" - 20 x 3/4"	2
8	131-934	NUT - 1/4" - 20 flange lock	5
9	C43962	COVER - solenoid.....	1
10	C43964	GROMMET - 1" x 7/8"	1
11	113-1	BOLT - 1/4" - 20 x 1/2"	3
12	C43963	MOUNT - solenoid	1
13	113-219	BOLT - 3/8" - 16 x 2"	1
14	131-1352	NUT - 3/8" - 16 lock.....	1
15	C43961	SPACER.....	1
16	C43960	STRAP - lift.....	1
17	C43412	DECAL - "Power Lift"	1
18	193-1000	NUT - #10-32	2
19	C44361	ARM - trip	1
20	C44364	MOUNT - trip arm.....	1
21	C44367	PIN - pivot.....	1
22	132-6	PIN - cotter 1/16" x 5/8"	2

**ELECTRICAL ASSEMBLY (DECK LIFT)
WINCH STYLE****INDEX**

1	C33024	SOLENOID - 12V	4
2	C43966	STRAP	4
3	C43983	BREAKER - 40 amp, 12V	1
4	193-1000	NUT - #10 - 32	2
5	C43969	HARNESS - wire	1
6	129-101	NUT - 1/4" -20	8
7	192-19	LOCKWASHER - 1/4"	8
8	113-1	BOLT - 1/4" - 20 x 1/2"	8
9	131-934	NUT - 1/4" - 20 flange	10
10	113-3	BOLT - 1/4" - 20 x 3/4"	2
11	C43965	BRACKET - switch	2
12	C33744	SWITCH - limit	2
13	C43985	SWITCH - lift	1
14	NSS	PLATE - switch identification (early production)	1
14	C44495	DECAL - switch identification (current production)	1
15	C44471	NUT - 15/32" - 32, switch	1
16	195-529	WASHER - 1/2"	1

INDEX

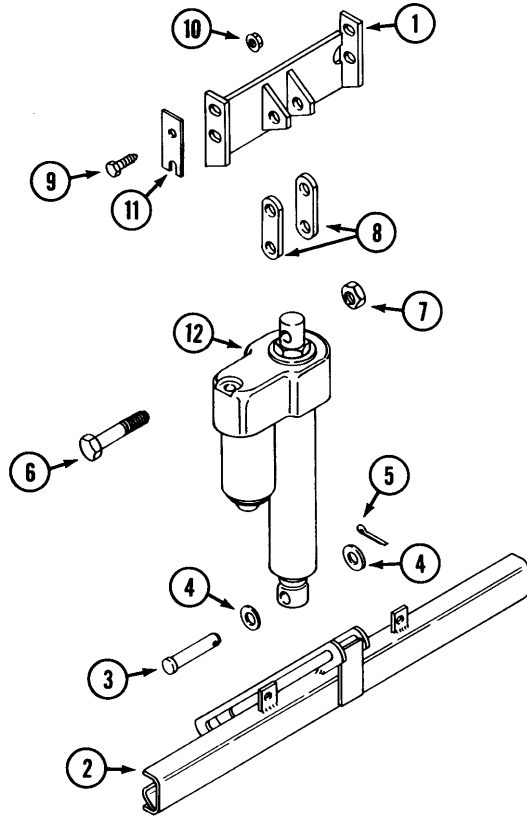

INDEX

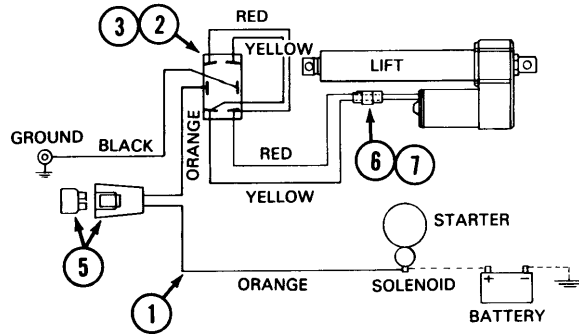

INDEX

**ELECTRIC DECK LIFT
CYLINDER STYLE**

REF.	PART NO.	DESCRIPTION	REQ'D
1	C45697	MOUNT - cylinder	1
2	C45700	BAR - cross	1
3	C29804	PIN - clevis 1/2" x 2-1/2"	1
4	195-2067	WASHER - 1/2"	2
5	132-320	PIN - cotter 3/32" x 3/4'	1
6	113-426	BOLT - 1/2" - 13 x 2-3/4"	2
7	131-1182	NUT - 1/2" - 13 lock	2
8	C45768	LINK - spacer	UAR
9	113-103	BOLT - 5/16" - 18 x 1"	4
10	131-911	NUT - 5/16" - 18 flange lock	4
11	C45766	SHIM - cylinder mount	UAR
12	C45706	CYLINDER - lift	1

**ELECTRICAL SYSTEM (DECK LIFT)
CYLINDER STYLE**

1	C45705	HARNESS - wire	1
2	C45775	SWITCH	1
3	C45780	NUT - 15/32" - 32 with boot (switch mounting)	1
4	C44495	DECAL - lift switch	1
5	C30261	HOLDER - fuse	1
5	C30260	FUSE - 30 amp	1
6	C24813	CONNECTOR - wire harness	1
7	C31948	CONNECTOR - lift actuator	1

TRANSMISSION - ZT DRIVE (5020V)

Phantom gear teeth on Ref. 3 must align with gear Ref. 23

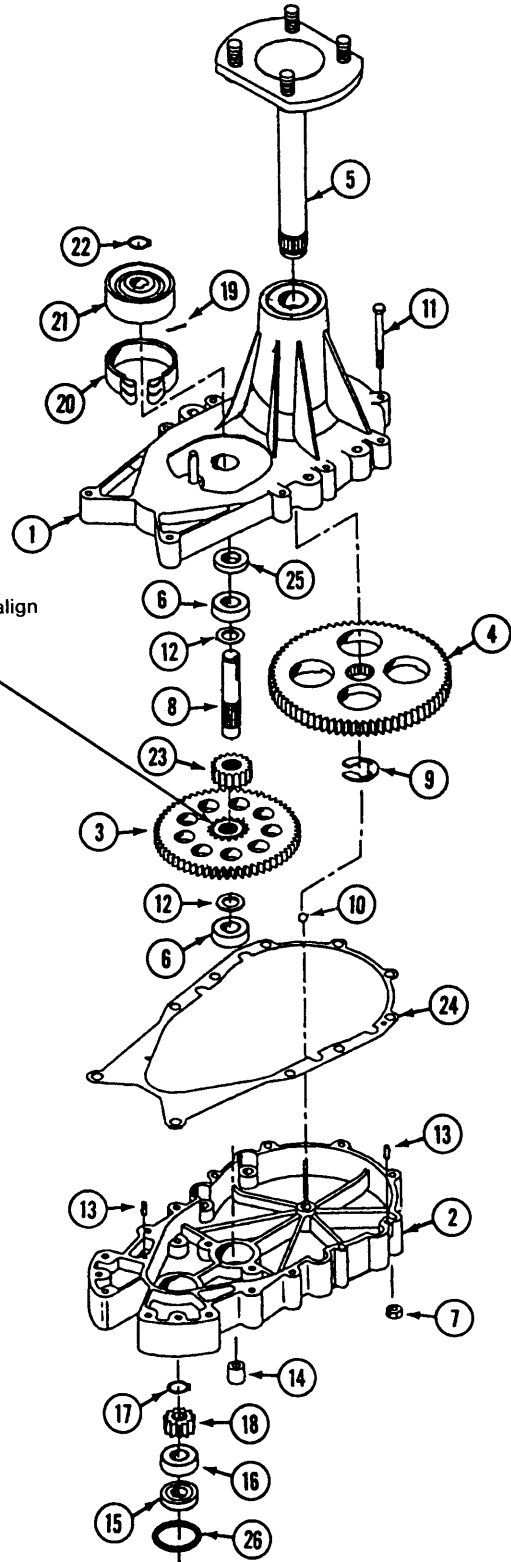
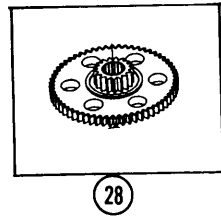

INDEX

**TRANSMISSION - ZT DRIVE
(5020V)**

REF.	PART NO.	DESCRIPTION	REQ'D
1	C40898	HOUSING - axle.....	1
	NSS	BEARING - ball.....	1
	NSS	BEARING - flanged.....	1
	NSS	PIN - clevis.....	1
2	C40902	HOUSING - hydro mount.....	1
3	C43685	GEAR - 60T.....	1
4	C40904	GEAR - drive.....	1
5	C40905	SHAFT - axle.....	1
6	C34464	BEARING.....	2
7	129-102	NUT - 5/16" -18.....	2
8	C40908	SHAFT - brake.....	1
9	C40909	RING - retaining.....	1
10	C40910	BALL - 3/8".....	1
11	113-12	BOLT - 1/4 - 20 x 2-1/2".....	UAR
11	113-119	BOLT - 5/16" - 18 x 2-3/4".....	UAR
12	C34447	WASHER.....	2
13	C34446	PIN - spiral.....	2
14	C37736	SPACER - mounting.....	2
15	C37740	SPACER - bearing.....	1
16	C37739	BEARING - ball.....	1
17	C37737	RING - retaining.....	1
18	C37738	GEAR - input.....	1
19	132-320	PIN - cotter.....	1
20	C37730	BAND - brake.....	1
21	C37731	DRUM - brake.....	1
22	C37732	RING - retaining.....	1
23	C43686	GEAR - 17T.....	1
24	C43687	GASKET-housing.....	1
25	C43688	SEAL - oil.....	1
26	C43689	"O" RING.....	1
27	C43752	GREASE - 10 oz. tube (2 required).....	2
28	NSS	GEAR - (use C43685, C43686).....	1

HYDROSTATIC PUMP-ZT DRIVE (5020V)

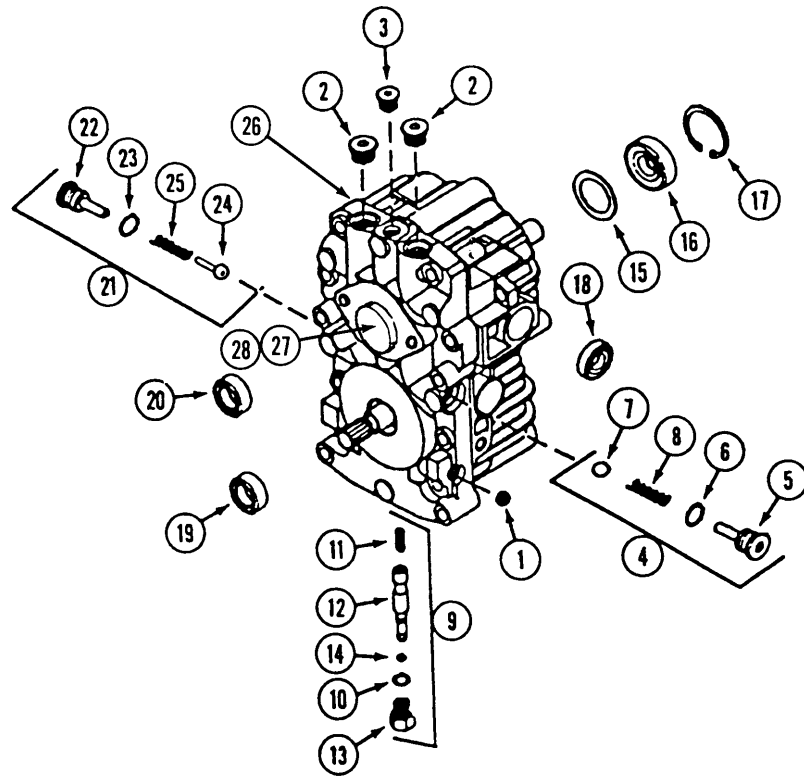

INDEX

**HYDROSTATIC PUMP-ZT DRIVE
(5020V)**

REF.	PART NO.	DESCRIPTION	REQ'D
	C45398	TRANSMISSION - hydrostatic L.H. (CW)	1
	C45399	TRANSMISSION - hydrostatic R.H. (CCW).....	1
1	C34124	PLUG - pipe	1
2	C34125	PLUG - 9/16- 18.....	2
3	C34126	PLUG - 7/16-20.....	1
4	C43690	KIT - check valve (with check ball) top	2
5	NSS	PLUG - check valve	1
6	NSS	"O" RING - .078" x .468"	1
7	NSS	BALL - check.....	1
8	NSS	SPRING	1
9	C34128	KIT-bypass.....	1
10	NSS	"O" RING - .072 x .351	1
11	NSS	SPRING	1
12	NSS	SPOOL - by pass	1
13	NSS	PLUG - by pass.....	1
14	NSS	"O" RING	1
15	NSS	SPACER	1
16	NSS	SEAL - lip	1
17	NSS	RING - retaining.....	1
18	NSS	SEAL - lip	1
19	NSS	SEAL - lip	1
20	NSS	SEAL - lip	1
21	C45408	KIT - check valve (with poppet) bottom	1
22	NSS	PLUG - check valve	1
23	NSS	"O" RING - 078" x .468"	1
24	NSS	POPPET - check.....	1
25	NSS	SPRING	1
26	C43751	GASKET - body.....	1
27	C43750	KIT - charge pump	1
28	C43749	"O" - RING - charge pump cover.....	1
	C34129	KIT - seal (includes ref. 6, 10, 14, 15, 16, 17, 18, 19 and 20).....	1