

**COMPACT TRACTOR
1214
Parts Catalog 8-3270**

8-92-RP-500-264

PAINT AND OIL

REF.	PART NO.	DESCRIPTION	REQ'D
		PAINT	
1	C 28849	BLACK - semi - gloss, 12 oz spray (2 per carton)	1
2	C 28850	BLACK - semi - gloss, quart (2 per carton)	1
3	C 28851	BLACK - semi - gloss, heat resistant, 12 oz spray (2 per carton)	1
4	C 28484	POWER RED - gloss, 12 oz spray (2 per carton)	1
5	C 28485	POWER RED - gloss, quart (2 per carton)	1
6	C 30870	SILVER - gloss, 12 oz. spray (2 per carton)	1
7	C 31643	POWER RED - gloss, 1 oz touch up, (1 doz. per carton)	1
		OIL	
1	C 32776	OIL - SAE 30, SF, quart (12 per case)	1
2	C 32777	OIL - SAE 5W20, SF, quart (12 per case)	1
3	C 32778	OIL - SAE 20W40, SF, quart (12 per case)	1

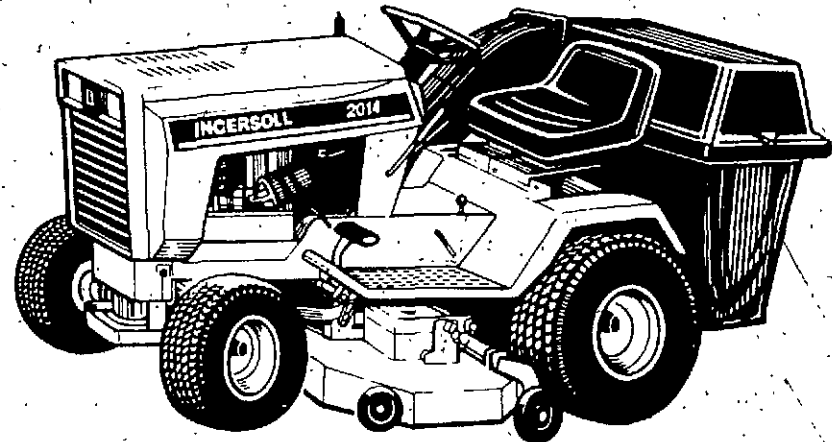

GENERAL INFORMATION

INDEX

There is an index at the front and rear of this catalog.

The front index is an alphabetical index of the major groups or assemblies.

The rear index is a numerical index of the part numbers and pages on which these numbers are shown.

ILLUSTRATION

Each illustration in this catalog shows a group of parts or components. These parts and components are aligned approximately as the parts and components on your machine. Each part and component in an illustration has a reference number. These reference numbers are in a list on the page opposite of the illustration. Next to the reference number is the part number, description and required quantity of the part shown in the illustration.

UAR - "Use as required" indicates that the part quantity is variable.

NSS - "Not sold separately" indicates that the part is only available as a component of an assembly or the part must be purchased locally. If the part is an assembly component, the description will be indented under the assembly description in the parts list.

O/L - "Obtain locally"

** - "Footnotes" are added to a part number when more information is needed for identification. They only relate to the part numbers indicated.

PARTS ORDERS

All orders must include the following information:

1. Correct part number.
2. Complete description of part or component.
3. Total quantity of each part or component.
4. Product model number.
5. All necessary product identification numbers.
6. Method for sending the parts.
7. Complete and correct address.

CATALOG REVISIONS

As the product changes, new pages will be available for your catalog. A notice will be issued.

IMPORTANT: Put all revisions into the catalog as soon as possible.

RIGHT HAND AND LEFT HAND IDENTIFICATION

The words right hand (RH) and left hand (LH) as used in this catalog indicate the direction while you are in the operator's seat in the normal operating position.

INDENTED DESCRIPTIONS

An assembly can have many components. The components of an assembly are indicated by an indented description. The quantity for an indented part is the total needed for that complete assembly. See the example.

REF.	PART NO.	DESCRIPTION	REQ'D
	C 55159	CYLINDER ASSY - rear steering	1
28	C 56208	SOCKET ASSY - rear cylinder	1
29	C 55956	PLUG - adjusting, socket assy	1
30	C 55957	SEAT - socket ball	2
31	C 56210	SPRING - socket	1
32	C 56209	SEAT - socket spring	1
33	G 45175	CLAMP ASSY - socket assy	1
	16- 836	BOLT - 1/2" x 2-1/4" N.F. hex	1
34	132- 104	PIN - cotter, 3/16" x 3"	1
35	C 55889	STUD - ball, socket & cylinder	2
36	13- 410	BOLT - 1/4" x 5/8" N.C., hex	4
37	92- 4	LOCK WASHER - 1/4" SAE	4

TABLE OF CONTENTS

	Page	Grid
Chassis and Hood	5	A6
Fender and Seat	7	A8
Mower Suspension Assembly	9	A10
Steering and Front Axle	11	A12
Rear Wheel Steering Assembly	13	A14
Motion Drive Assembly (shift)	15	B2
Motion Drive Assembly (clutch)	17	B4
Engine and Control Assembly	19	B6
Pre-Painted Deck Assembly	21	B8
Final Deck Assembly	23	B10
Electrical Assembly	25	B12
Decals	27	B14
Transaxle Assembly	29	C2
Flywheel, Crankshaft, Camshaft and Piston	31	C4
Cylinder Block, Head and Crankcase	33	C6
Engine Base, Dipstick and Oil Filter	35	C8
Ignition and Charging System	35	C8
Carburetor	37	C10
Air Cleaner	39	C12
Governor	39	C12
Engine Air Baffles and Breather	41	C14
Exhaust System	41	C14
Starter	43	D2
Engine Gasket Kit	43	D2

CHASSIS AND HOOD

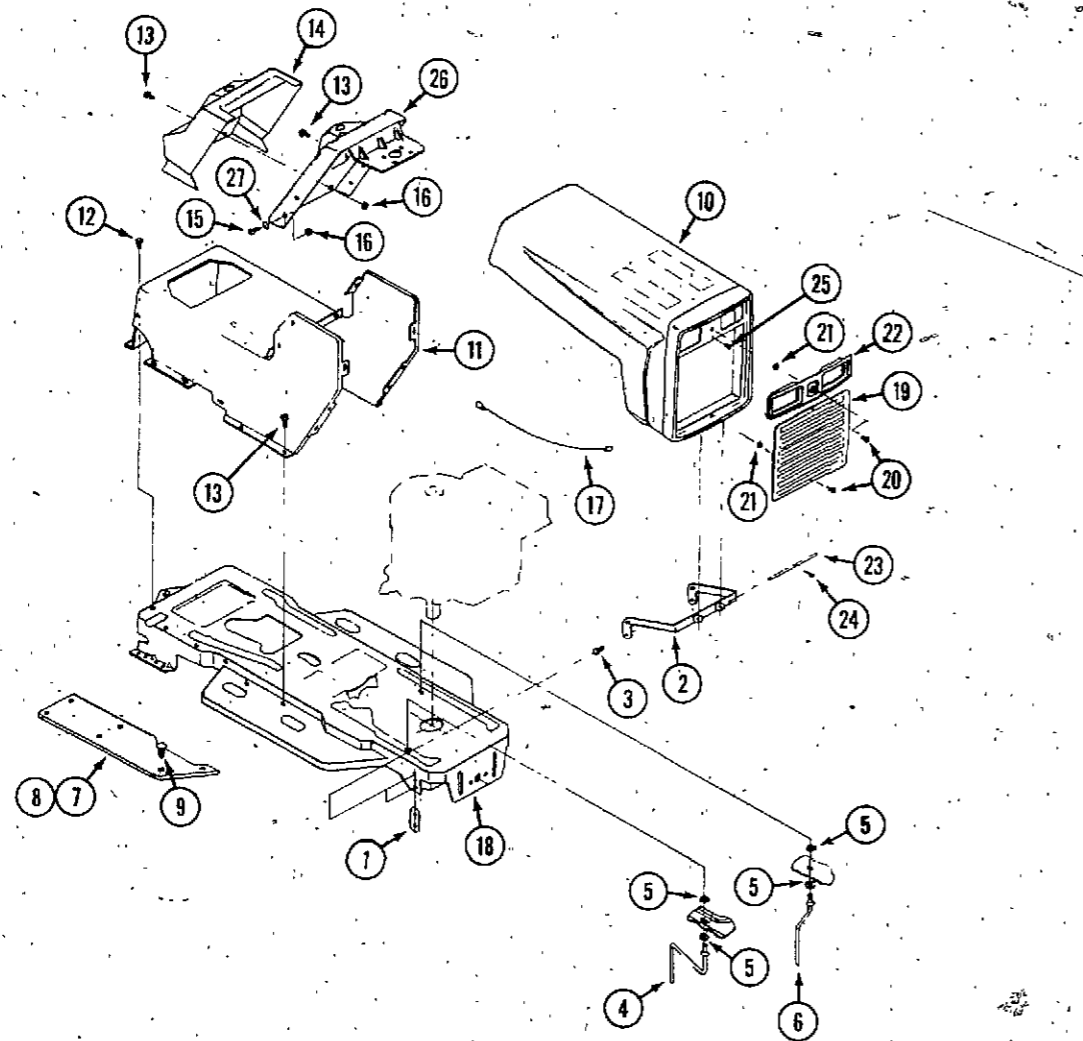

REF.	PART NO.	DESCRIPTION	REQ'D
1	C 40714	PLATE - backing	2
2	C 40715	BRACKET - hood pin	1
3	113- 102	BOLT - 5/16" - 18 x 3/4"	4
4	C 35073	GUIDE - belt	1
5	131- 911	NUT - 5/16" - 18 flange lock	4
6	C 35077	GUIDE - belt	1
7	C 35065	PAD - foot L.H.	1
8	C 35066	PAD - foot R.H.	1
9	C 35067	FASTENER - ratchet	12
10	C 39521	HOOD	1
11	C 40660	CONSOLE	1
12	C 34848	SCREW - 5/16" - 18 x 1/2" tapping	1
13	187- 1036	SCREW - 1/4" - 20 x 1/2" tapping	12
14	C 35377	DASH	1
15	113- 3	SCREW - 1/4" - 20 x 5/8"	4
16	131- 934	NUT - 1/4" - 20 flange lock	6
17	C 37147	LANYARD	1
18	C 39506	FRAME - main	1
19	C 31365	GRILLE	1
20	C 31597	SCREW - 1/4" - 20 x 1/2"	2
21	131- 934	NUT - 1/4" - 20 flange lock	2
22	C 31366	SHROUD - headlight	1
23	C 16362	ROD - hinge	1
24	132- 334	PIN - cotter	1
25	187- 1328	SCREW - #8 - 18 x 3/8"	1
26	C 35082	TOWER	1
27	195- 520	WASHER - 1/4"	2

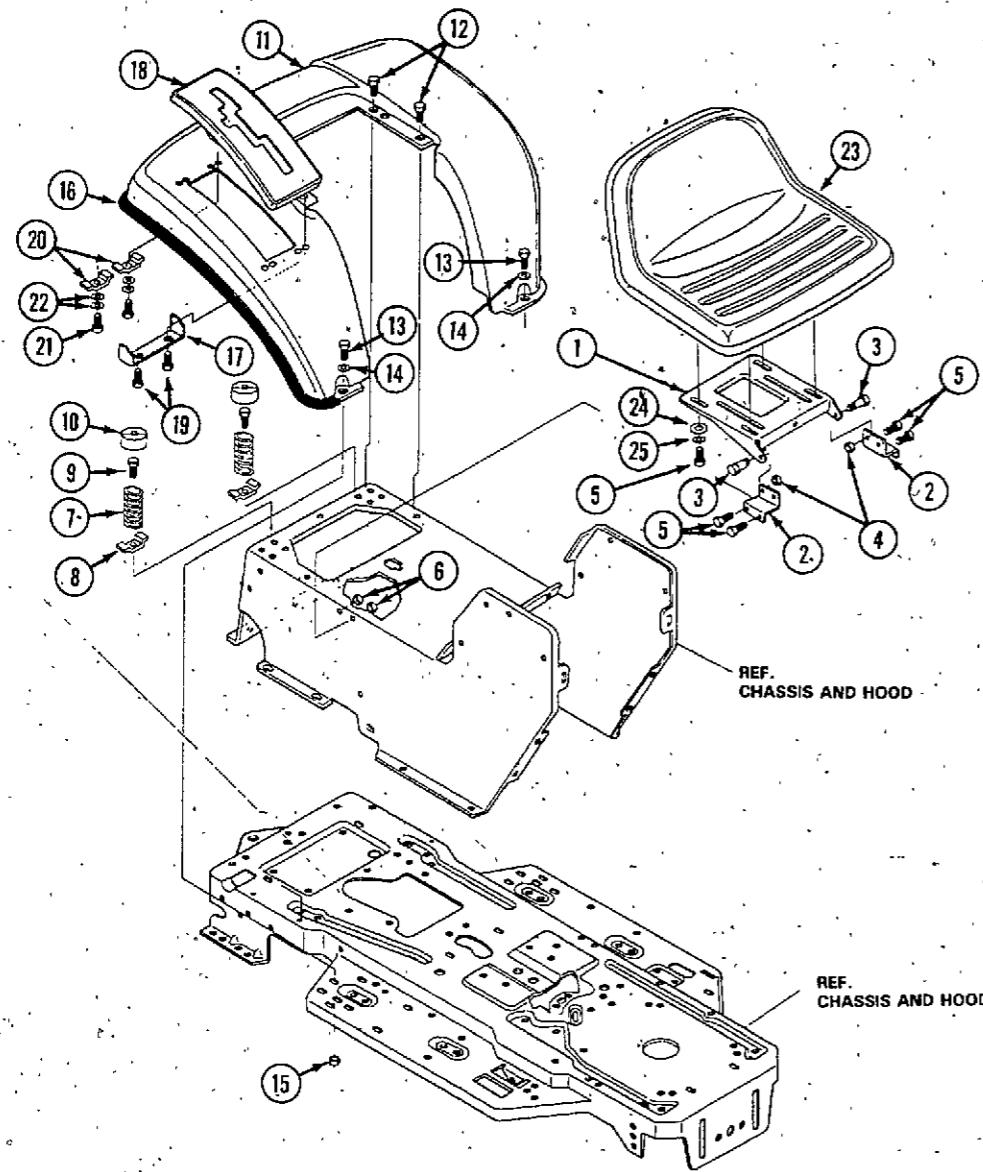

LAWN TRACTOR MODEL 1214

FENDER AND SEAT

REF.	PART NO.	DESCRIPTION	REQ'D
1	C 40661	PLATE - seat	1
2	C 35667	BRACKET - seat support	1
3	C 34816	BOLT - .437" x .156" / 5/16" - 18 thread	2
4	131- 176	NUT - 5/16" - 18 lock	2
5	113- 102	SCREW - 5/16" - 18 x .63 HHC GR2	4
6	131- 911	NUT - 5/16" - 18 lock	4
7	C 35112	SPRING - seat 2.63" LG, 1.49" OD	2
8	C 35113	CLAMP - spring 1.17" ID	2
9	C 34803	SCREW - 1/4" - 20 x .75" tap	2
10	C 35114	COVER - seat spring 1.5" ID x 1.0" LG	2
11	C 35385	FENDER	1
12	187- 1036	SCREW - 1/4" - 20 x .50" tap	4
13	113- 103	SCREW - 5/16" - 18 x 1.00"	2
14	195- 102	WASHER - flat .375" x .88" x .082"	4
15	131- 911	NUT - 5/16" - 18 flange lock	2
16	C 35117	TRIM - strip, black	77.5
17	C 35118	BRACKET - cover	1
18	C 35119	COVER - plastic	1
19	C 35120	SCREW - 1/4" - 15 x .44" / .53"	2
20	C 35113	CLAMP - spring 1.17" ID	2
21	C 35120	SCREW - 1/4" - 15 x .44" / .53"	2
22	195- 518	WASHER - flat .261" x .63" x .065"	2
23	C 35366	SEAT	1
24	195- 521	WASHER - 5/16"	4
25	192- 20	WASHER - 5/16" lock	4

MOWER SUSPENSION ASSEMBLY

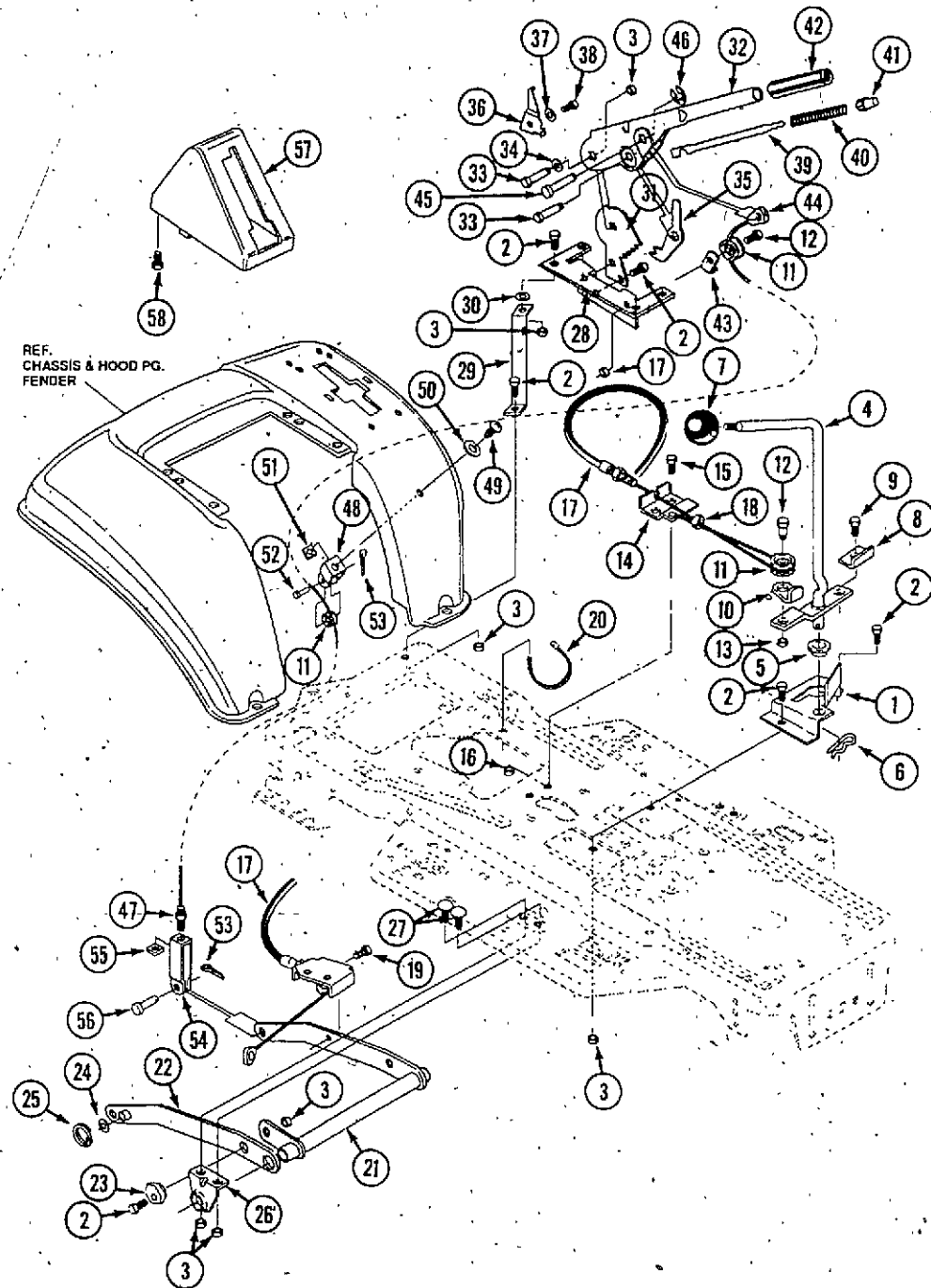

REF.	PART NO.	DESCRIPTION	REQ'D
1	C 35123	BRACKET - clutch, engage lever	1
2	113- 103	SCREW - 5/16" - 18 x 1.00"	9
3	131- 911	NUT - 5/16" - 18 flange	16
4	C 35125	LEVER - clutch	1
5	C 35126	BEARING - flange .503" ID x .628" OD	1
6	C 16450	PIN - hair .091" dia x 1.66" LG	1
7	C 35053	KNOB - shift	1
8	C 35127	BRACKET - switch engage	1
9	C 29620	SCREW - 5/16" - 18 x .75" tap	1
10	C 35128	BRACKET - cable retainer	1
11	C 35129	PULLEY - .906 x .305" nylon	1
12	C 35130	BOLT - .375" x .375" x 1/4" - 20	2
13	131- 934	NUT - 1/4" - 20 flange lock	1
14	C 35131	BRACKET - frame cable	1
15	113- 3	SCREW - 1/4" - 20 x .75"	2
16	131- 934	NUT - 1/4" - 20 lock	3
17	C 35133	CABLE ASSEMBLY - blade engage	1
18	C 35134	NUT - 1/4" - 28 jam	1
19	C 29620	SCREW - 5/16" - 18 x .75" tap	1
20	C 35334	TIE - cable, black nylon	1
21	C 35388	LIFT ASSEMBLY - rear	1
22	C 35137	LINK ASSEMBLY - right side	1
23	C 35139	NUT - adjusting	1
24	195- 533	WASHER - flat .531" x 1.06" x .095"	2
25	C 28105	RING - retaining	2
26	C 35140	BRACKET - rear, hanging suspension	2
27	111- 202	BOLT - 5/16" - 18 x .63" carriage	4
28	C 35141	BRACKET - height adjust support	1
29	C 35142	BRACE, fender	1
30	195- 521	WASHER - flat .333" x .87" x .119"	1
31	C 35143	QUADRANT - height adjust	1
32	C 35144	HANDLE - lift	1
33	C 35145	BOLT - 5/16" - 18	2
34	C 28806	WASHER - flat .506" x .75" x .024"	1
35	C 35147	PAWL - height adjust	1
36	C 35148	POINTER	1
37	193- 6	WASHER - 195" x .41" x .03" lock	1
38	C 34968	SCREW - #8 - 32 x .38"	1
39	C 35150	ROD - actuator, short	1
40	C 35151	SPRING - height adjust	1
41	C 35152	KNOB - height adjust	1
42	C 35153	GRIP - .750 OD w/hole	1
43	C 35154	BRACKET - cable retaining	1
44	C 34823	CABLE - lift 21.70"	1
45	C 35156	PIN - clevis .310" DIA x .475" LG	1
46	C 35157	RING - .31" x .24" retaining	1
47	129- 101	NUT - 1/4" - 20	1
48	C 35159	CLEVIS	1
49	C 35160	SCREW - 5/16" - 18 x .56"	1
50	C 35161	WASHER .344" ID x 1.5" OD x .09"	1
51	C 35162	NUT - 5/16" - 18 square	1
52	C 35163	PIN - clevis .38" DIA x 1.00" LG	1
53	132- 329	PIN - cotter	1
54	C 34825	CLEVIS - lift cable	1
55	C 34824	NUT - 1/4" - 20 square	1
56	C 34826	PIN CLEVIS .312" x .812"	1
57	C 35165	LIFT COVER	1
58	C 35166	SCREW - #10 x .75"	3

STEERING AND FRONT AXLE

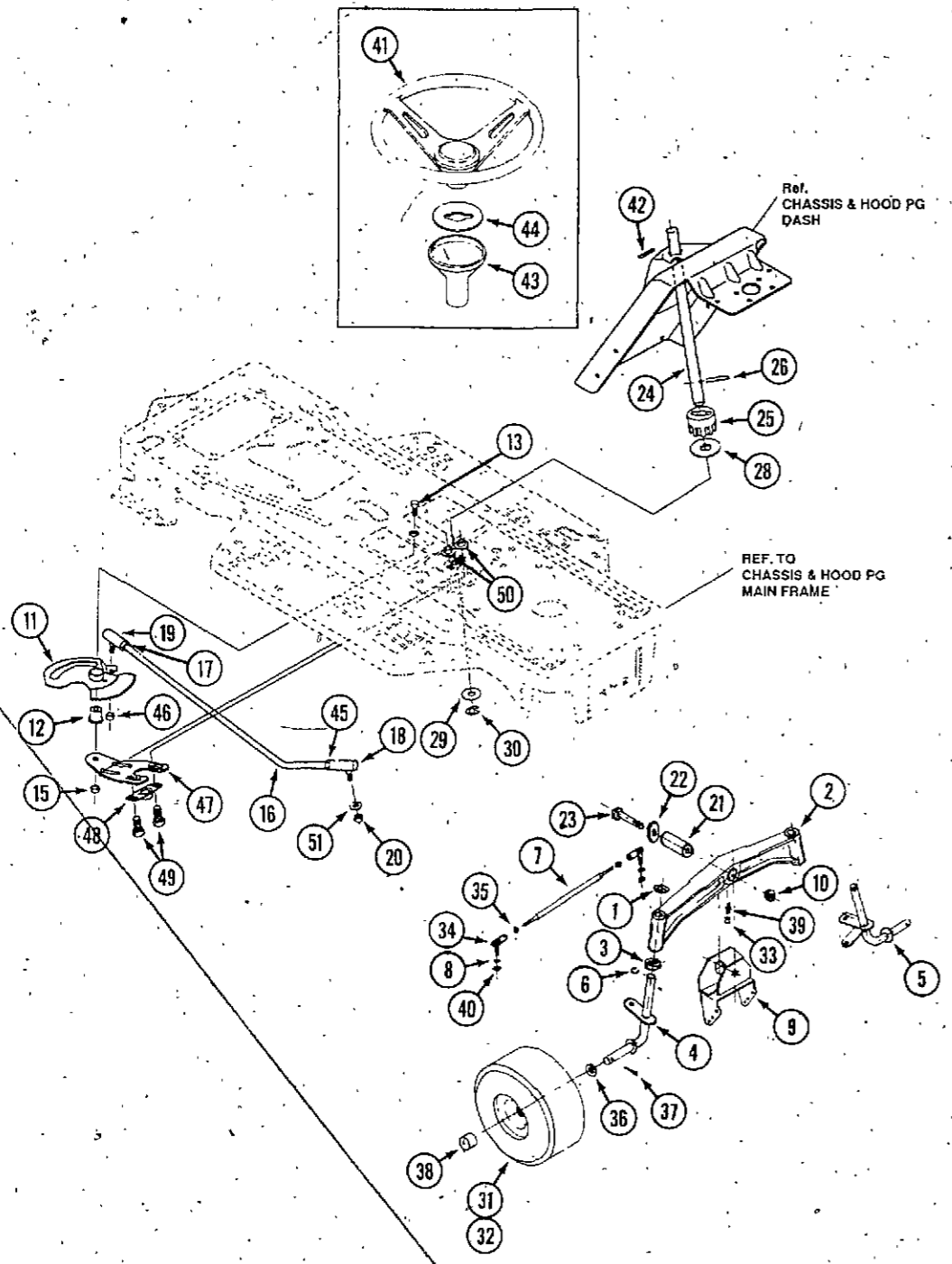

REF.	PART NO.	DESCRIPTION	REQ'D
1	195- 545	WASHER	2
2	C 18812	AXLE - front	1
3	C 11906	WASHER - thrust	4
4	C 39496	SPINDLE RH	1
5	C 40709	SPINDLE LH	1
6	C 28232	RING - retaining	2
7	C 40658	TIE ROD	1
8	192- 23	WASHER - 1/2" lock	2
9	C 39502	BRACKET - pivot	1
10	C 39497	NUT - axle pivot	2
11	C 35175	SECTOR - steering	1
12	C 35176	BEARING - flange	1
13	C 35178	SCREW - 1/2" - 13 x 3"	1
15	C 35219	NUT - 1/2" - 20 lock	1
16	C 40706	LINK - steering	1
17	129- 163	NUT - 3/8" - 24 jam	2
18	C 35185	BALL JOINT - 7/16" - 20	1
19	C 35183	BALL JOINT 3/8" TH'D long stud	1
20	C 35187	NUT - 7/16" - 20	1
21	C 39498	PIN - axle pivot	1
22	C 39499	WASHER - axle pivot	1
23	113- 447	BOLT - 1/2" - 13 x 3-1/2"	1
24	C 35188	SHAFT - steering	1
25	G 35189	PINION - steering	1
26	C 35190	PIN - dowel .25" OD x 1.75"	1
28	C 35191	WASHER - formed 1-3/8" x 1/2"	1
29	C 35192	WASHER - flat 3/4" x 1/2"	1
30	C 27739	RING - retaining	1
31	*	TIRE & RIM - 15 x 6.0 x 6 silver	2
	C 34920	VALVE STEM	1
	C 35193	RIM - with bearing	1
	C 35404	BEARING - flange 1.38" OD x .753" ID	1
32	**	TIRE	1
33	C 13106	COVER - lubrication fitting	3
34	C 12102	BALLJOINT - R.H. thread	1
34	C 13605	BALLJOINT - L.H. thread	1
35	129- 165	NUT - 1/2" N.F. R.H. thread	1
35	129- 365	NUT - 1/2" N.F. L.H. thread	1
36	C 28226	WASHER - flat	UAR
37	132- 311	PIN - cotter	2
38	C 26526	CAP - 1.5" ID x 7/8" LG hub	2
39	219- 17	FITTING - lubrication	3
40	129- 165	NUT - 1/2" N.F. R.H. thread	2
41	C 40666	WHEEL - steering	1
42	138- 143	PIN - roll 1/4" x 2"	1
43	C 40654	BOOT - steering shaft	1
44	C 40655	INSERT - boot	1
45	C 35184	NUT - 7/16" - 20	1
46	C 35186	NUT - 3/8" - 24 flange lock	1
47	C 35177	SUPPORT - sector gear	1
48	C 35180	BEARING - flange	1
49	C 35071	BOLT - 5/16" - 18 x 3/4" flange lock	2
50	131- 911	NUT - 5/16" - 18 flange lock	2
51	192- 22	LOCKWASHER - 7/16"	1

* Order individual parts.
 ** Order tires at your local tire dealer.

REAR WHEEL STEERING ASSEMBLY

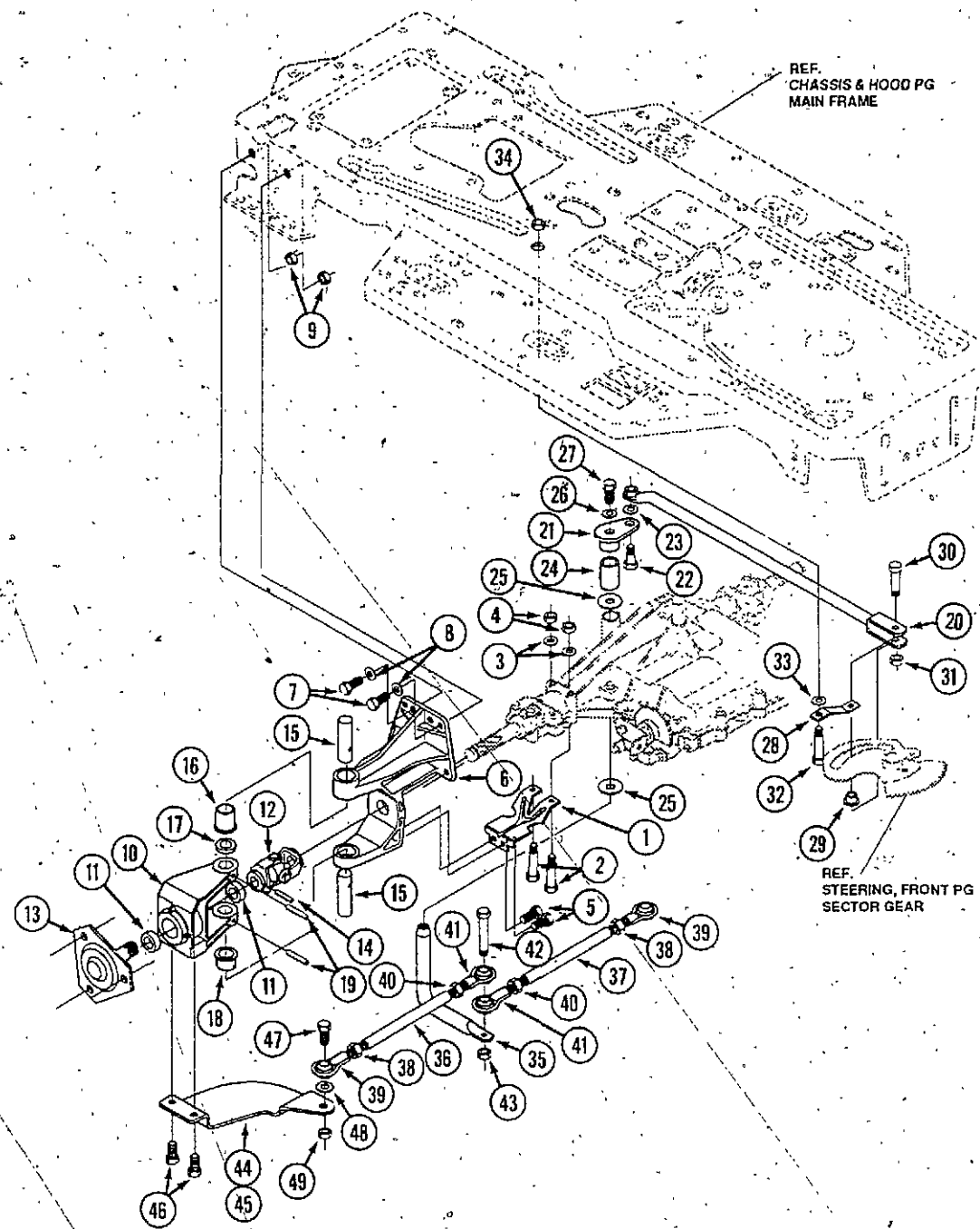

REF.	PART NO.	DESCRIPTION	REQ'D
1	C 35196	BRACKET - support	2
2	113- 110	SCREW - 5/16" - 18 x 2.25"	4
3	195- 521	WASHER - flat .344" x .69" x .065"	4
4	131- 176	NUT - 5/16" - 18 lock	4
5	C 35198	SCREW - 5/16" - 18 x .63" tap	4
6	C 35199	BRACKET - steering pivot	2
7	113- 103	SCREW - 5/16" - 18 x 1.00"	8
8	195- 521	WASHER - flat .344" x .69" x .065"	8
9	131- 176	NUT - 5/16" - 18 lock	8
10	C 35200	BRACKET - steering pivot	2
11	C 35201	BEARING	4
12	C 35202	UNIVERSAL JOINT	2
13	C 35203	HUB ASSEMBLY - grey	2
14	C 35204	PIN - gooved .250" DIA x 1.50" LG	2
15	C 35205	PIN - steering hinge	4
16	C 35206	BUSHING - shoulder (oilite)	2
17	C 35207	WASHER - flat .765" x 1.25" x .042"	2
18	C 35208	BUSHING - shoulder (oilite)	2
19	C 35209	PIN - spring .250" DIA x 1.50" LG	4
20	C 35210	ROD ASSEMBLY - drag link	1
21	C 35211	PIVOT - steering	1
22	C 35212	BOLT - .562" x .340" 3/8" - 24	1
23	195- 104	WASHER - flat .406" x .81" x .065"	1
24	C 35213	SPACER - steering shaft	1
25	C 28226	WASHER - flat .765" x 1.19" x .048"	2
26	C 34899	WASHER - flat .333" x .87" x .119"	1
27	C 35215	SCREW - 5/16" - 24 x 1.00"	1
28	C 35216	ARM - roller swing	1
29	C 35217	ROLLER - cam yoke	1
30	C 35218	BOLT - shoulder	1
31	C 35219	NUT - 1/2" - 20 lock	1
32	C 35220	BOLT - shoulder	1
33	195- 104	WASHER - flat .406" x .81" x .065"	1
34	C 35221	NUT - 3/8" - 24 lock	1
35	C 35222	SHAFT - steering pivot	1
36	C 35223	ROD - tie 1/2" D x 8.00" LG	1
37	C 35224	ROD - tie 1/2" D x 9.5" LG	1
38	129- 289	NUT - 3/8" - 24 LH thread	2
39	C 35226	ROD - tie end LH - 3/8" - 24	2
40	129- 163	NUT - 3/8" - 24	2
41	C 35227	ROD - tie end RH	2
42	C 35641	SCREW - 3/8" - 24 x 1.75"	1
43	C 35221	NUT - 3/8" - 24 lock	1
44	C 35229	ARM - RH	1
45	C 35230	ARM - LH	1
46	C 35231	SCREW - 3/8" - 16 x .75" tap	4
47	C 35232	SCREW - 3/8" - 24 x 1.25"	2
48	192- 21	WASHER - 3/8" lock	2
49	C 35221	NUT - 3/8" - 24 lock	2

MOTION DRIVE ASSEMBLY (SHIFT)

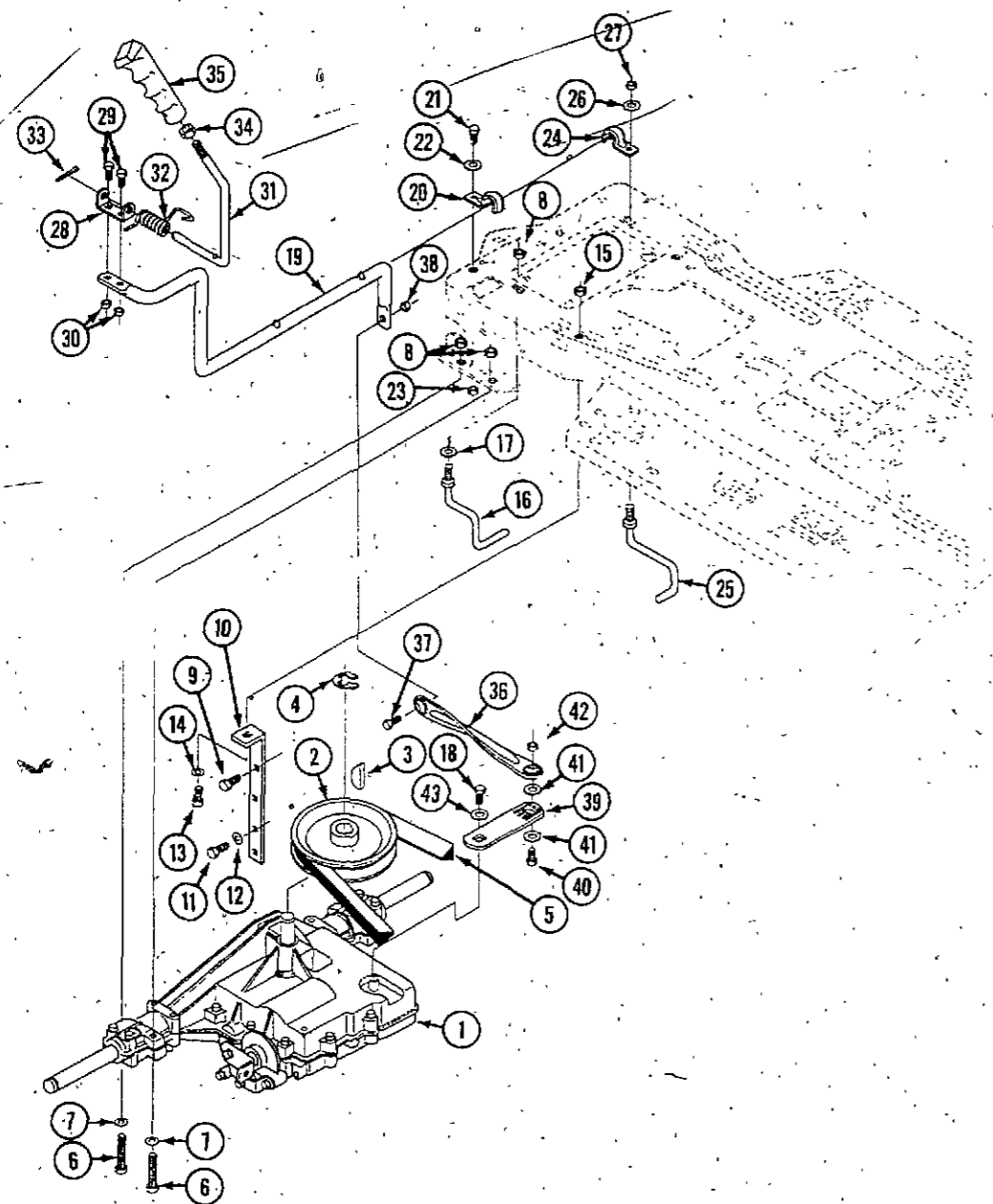

REF.	PART NO.	DESCRIPTION	REQ'D
1	C 40667	TRANSAXLE ASSEMBLY - repairs page 29	1
2	C 34873	PULLEY - input	1
3	C 34909	KEY - woodruf #606 .750" x .187" x .312"	1
4	C 34874	RING - .58" x .04"	1
5	C 35233	BELT - V 4L 87.25"	1
6	113- 110	SCREW - 5/16" - 18 x 2.25"	4
7	195- 521	WASHER - flat .344" x .69" x .065"	4
8	131- 176	NUT - 5/16" - 18 lock	4
9	C 35264	SCREW - 3/8" - 16 x 1.25" tap	1
10	C 35235	BRACKET - stabilizer	1
11	C 34800	SCREW - 5/16" - 18 x .75" tap	2
12	192- 20	WASHER - .328" x .60" x .09" lock	2
13	113- 103	SCREW - 5/16" - 18 x 1.00"	1
14	195- 521	WASHER - flat .344" x .69" x .065"	1
15	131- 176	NUT - 5/16" - 18 lock	1
16	C 35236	GUIDE - belt 5/16" - 18 THD	1
17	192- 20	WASHER - .328" x .60" x .09" lock	1
18	C 34887	SCREW - 1/4" - 28 x .75" grade 8	1
19	C 35238	LEVER - shift	1
20	C 35239	CLIP - shift lever .62" rod	1
21	113- 102	SCREW - 5/16" - 18 x .75"	1
22	C 35240	WASHER - flat .391" x 1.00" x .125"	1
23	131- 176	NUT - 5/16" - 18 lock	1
24	C 35239	CLIP - shift lever .62" rod	1
25	C 35241	GUIDE - belt 5/16" - 18 THD	1
26	C 35240	WASHER - flat .391" x 1.00" x .125"	1
27	C 34798	NUT - 5/16" - 18 lock	1
28	C 35242	BRACKET - pivot, shift lever	1
29	113- 2	SCREW - 1/4" - 20 x .62"	2
30	131- 1102	NUT - 1/4" - 20 lock	2
31	C 35244	LEVER - shift, upper	1
32	C 35426	SPRING - torsion	1
33	132- 310	PIN - cotter .125" DIA x 1.00" LG	1
34	129- 105	NUT - 1/2" - 13	1
35	C 35247	HANDLE - 1/2" - 13 molded	1
36	C 35554	LINK - tie rod, shift	1
37	113- 208	SCREW - 3/8" - 16 x 1.25"	1
38	131- 1216	NUT - 3/8" - 16 lock	1
39	C 35250	BRACKET - shift	1
40	113- 208	SCREW - 3/8" - 16 x 1.25"	1
41	195- 104	WASHER - flat .406" x .81" x .065"	2
42	113- 1216	NUT - 3/8" - 16 lock	1
43	C 34886	WASHER - .750" x .250"	1

MOTION DRIVE ASSEMBLY (CLUTCH)

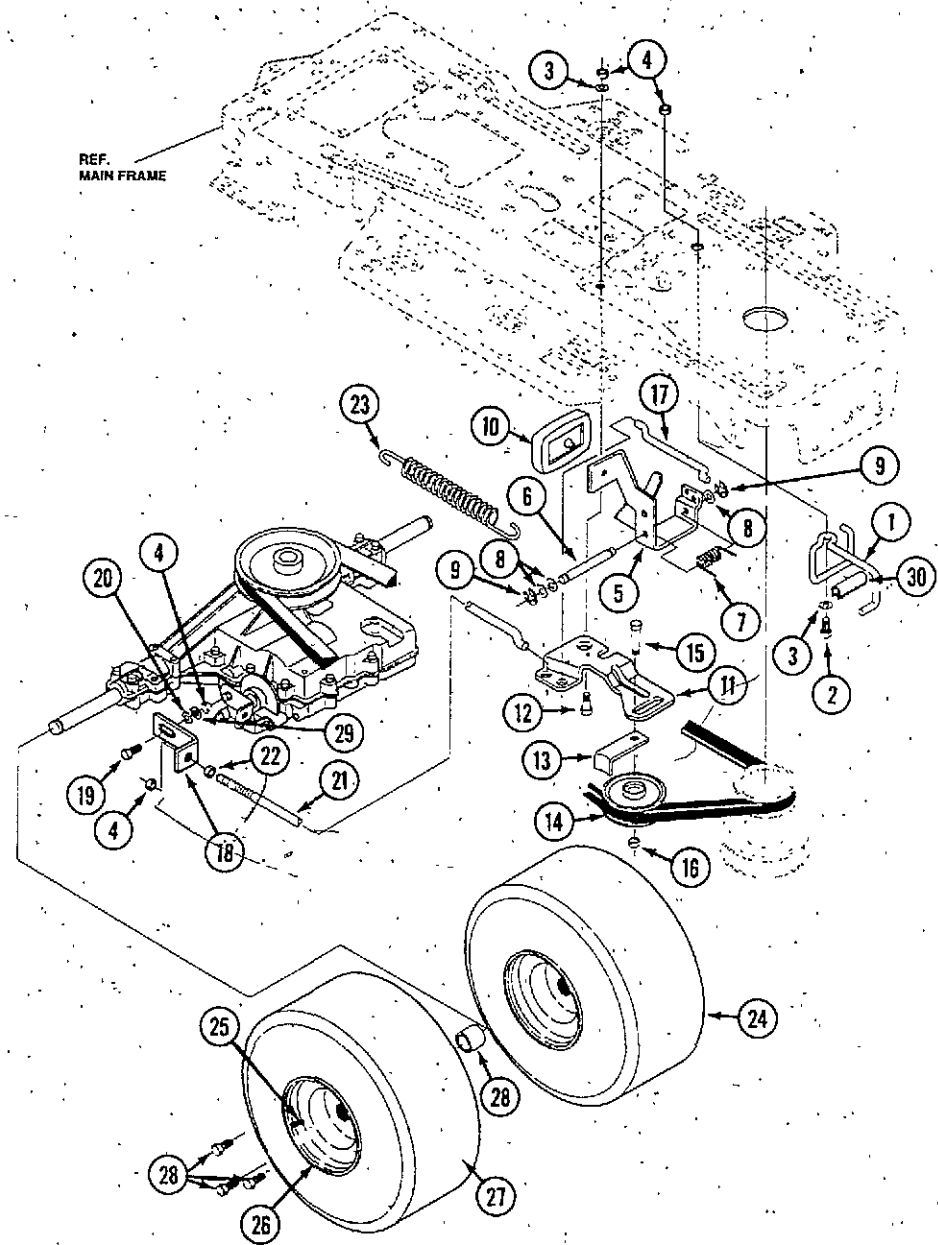

REF.	PART NO.	DESCRIPTION	REQ'D
1	C 35251	GUIDE - belt, drag link	1
2	113- 103	SCREW - 5/16" - 18 x 1.00"	1
3	C 34899	WASHER - flat .333" x .87" x .119"	1
4	131- 176	NUT - 5/16" - 18 lock	1
5	C 35254	PEDAL ASSEMBLY - brake, clutch	1
6	C 34980	ROD - pivot .50" OD x 4.44" LG	1
7	C 35255	SPRING - brake pedal	1
8	C 35192	WASHER - flat .504" x .75" x .059"	3
9	C 34979	RING - retaining	2
10	C 35256	PAD - clutch brake	1
11	C 35257	ARM - idler, traction drive	1
12	C 35258	BOLT - .625" x .135", 5/16" - 18	1
13	C 34903	RETAINER - belt	1
14	C 34902	PULLEY - idler V4L 3.06" x .62"	1
15	111- 330	BOLT - 3/8" - 16 x 1-3/4" carriage	1
16	131-1216	NUT - 3/8" - 16 lock	1
17	C 35259	ROD - clutch	1
18	C 34993	BRACKET - brake rod	1
19	C 34816	BOLT - .437" x .156", 5/16" - 18 thread	1
20	195- 520	WASHER - flat .33" x .87" x .119"	1
21	C 35260	ROD - brake 23.50	1
22	C 34833	NUT - 5/16" - 18	1
23	C 35261	SPRING - clutch - .113" x .750" x 8.75"	1
24	*	WHEEL ASSEMBLY - 20 - 10 x 8	2
25	C 34920	VALVE STEM	1
26	C 35262	RIM - wheel	1
27	**	TIRE	1
28	C 35263	SCREW - 1/2" - 20 x .50"	6
29	195- 521	WASHER - 5/16" - 11/16"	1
30	C 35253	PLASTIC EXTRUSION - belt guide	1

* Order Individual Parts
 ** Order Tires at Local Tire Dealer

ENGINE AND CONTROL ASSEMBLY

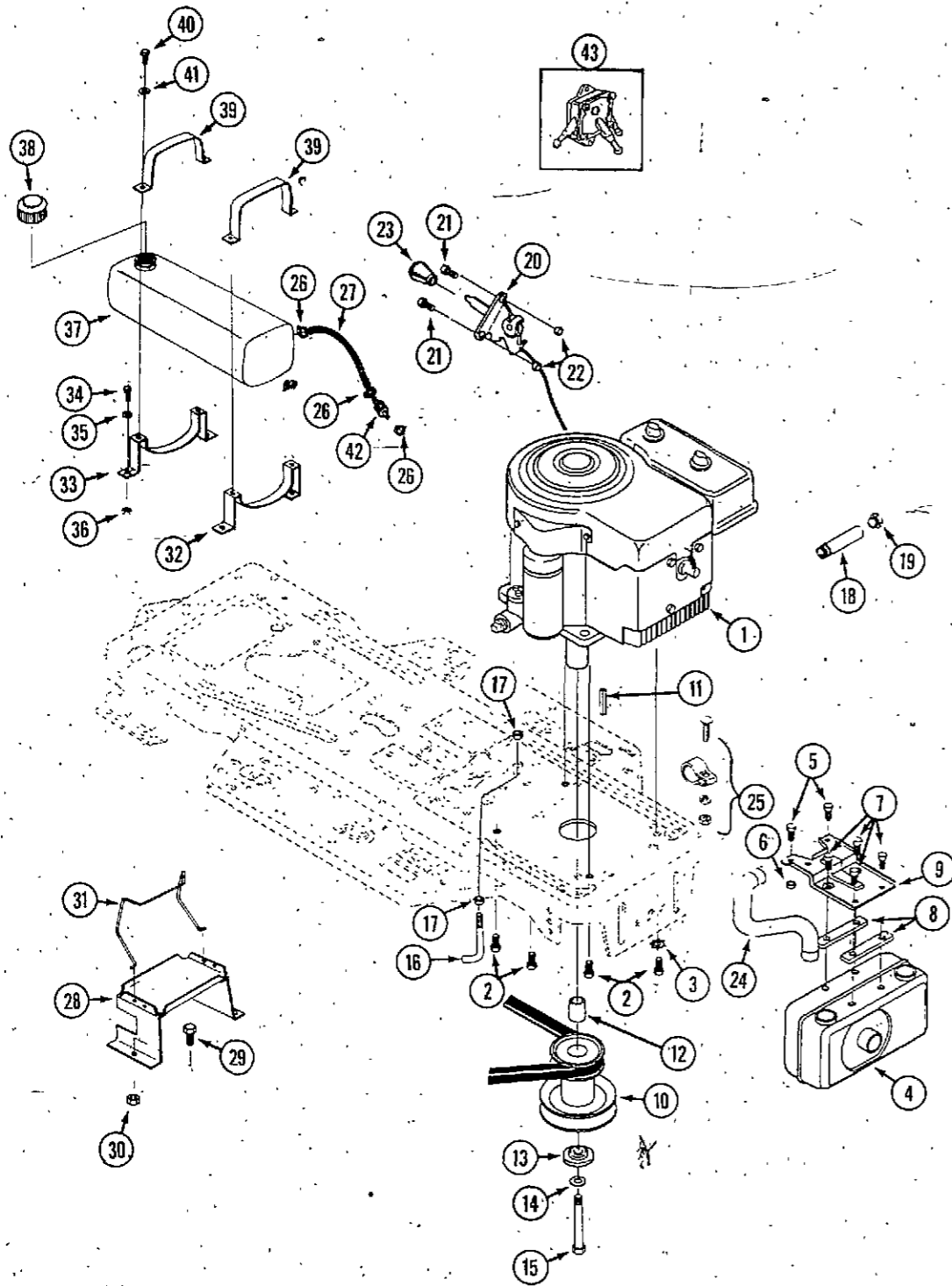

REF.	PART NO.	DESCRIPTION	REQ'D
1	C 42812*	ENGINE - 14 hp Briggs & Stratton model 261777 type 0159	1
2	C 35264	SCREW - 3/8" - 16 x 1-1/4" tapping	4
3	192- 21	LOCKWASHER	1
4	C 42810	MUFFLER	1
5	113- 102	SCREW - 5/16" - 18 x 3/4"	2
6	131- 911	NUT - 5/16" - 18 flange lock	2
7	C 34808	SCREW - 1/4" - 20 x 3/4" tapping	4
8	C 35271	PLATE - muffler spacer	3
9	C 42820	BRACKET - muffler mounting	1
10	C 35277	PULLEY - engine	1
11	C 35278	KEY - square 1/4" x 5"	1
12	C 35279	SPACER - pulley	1
13	C 34925	WASHER	1
14	192- 22	LOCKWASHER - 7/16"	1
15	C 35280	BOLT - 7/16" - 20 x 5"	1
16	C 35283	ROD - upstop	1
17	131- 938	NUT - 3/8" - 16 flange lock	1
18	C 37148	NIPPLE - pipe 3/8" - 18 NPT x 2"	1
19	218- 5154	PLUG - 1/2" - 20	1
20	C 35447	CONTROL - throttle	1
21	C 35289	SCREW - #10 - 24 x 5/8"	2
22	C 35290	NUT - #10 - 24	2
23	C 35291	KNOB - throttle	1
24	C 42807	PIPE - exhaust	1
25	C 42814	CLAMP - muffler 1-3/8"	1
26	C 32376	CLAMP - fuel line	4
27	NSS	HOSE - fuel (use C28937 cut to length)	2
28	C 39514	BRACKET - battery support	1
29	113- 102	BOLT - 5/16" - 18 x 3/4"	2
30	131- 911	NUT - 5/16" - 18 flange lock	2
31	C 42363	RETAINER - battery	1
32	C 40737	BRACKET - fuel tank	1
33	C 37482	BRACKET - fuel tank	1
34	113- 103	BOLT - 5/16" - 18 x 1"	4
35	195- 521	WASHER - 5/16"	4
36	131- 911	NUT - 5/16" - 18 flange lock	4
37	C 37472	TANK - fuel	1
38	C 37094	CAP - fuel tank	1
39	C 37481	STRAP - fuel tank	2
40	113- 103	BOLT - 5/16" - 18 x 1"	4
41	195- 521	WASHER - 5/16"	4
42	C 31978	FILTER - fuel	1
43	C 34300	PUMP - fuel	1

*See engine section for repairs

PRE-PAINTED DECK ASSEMBLY

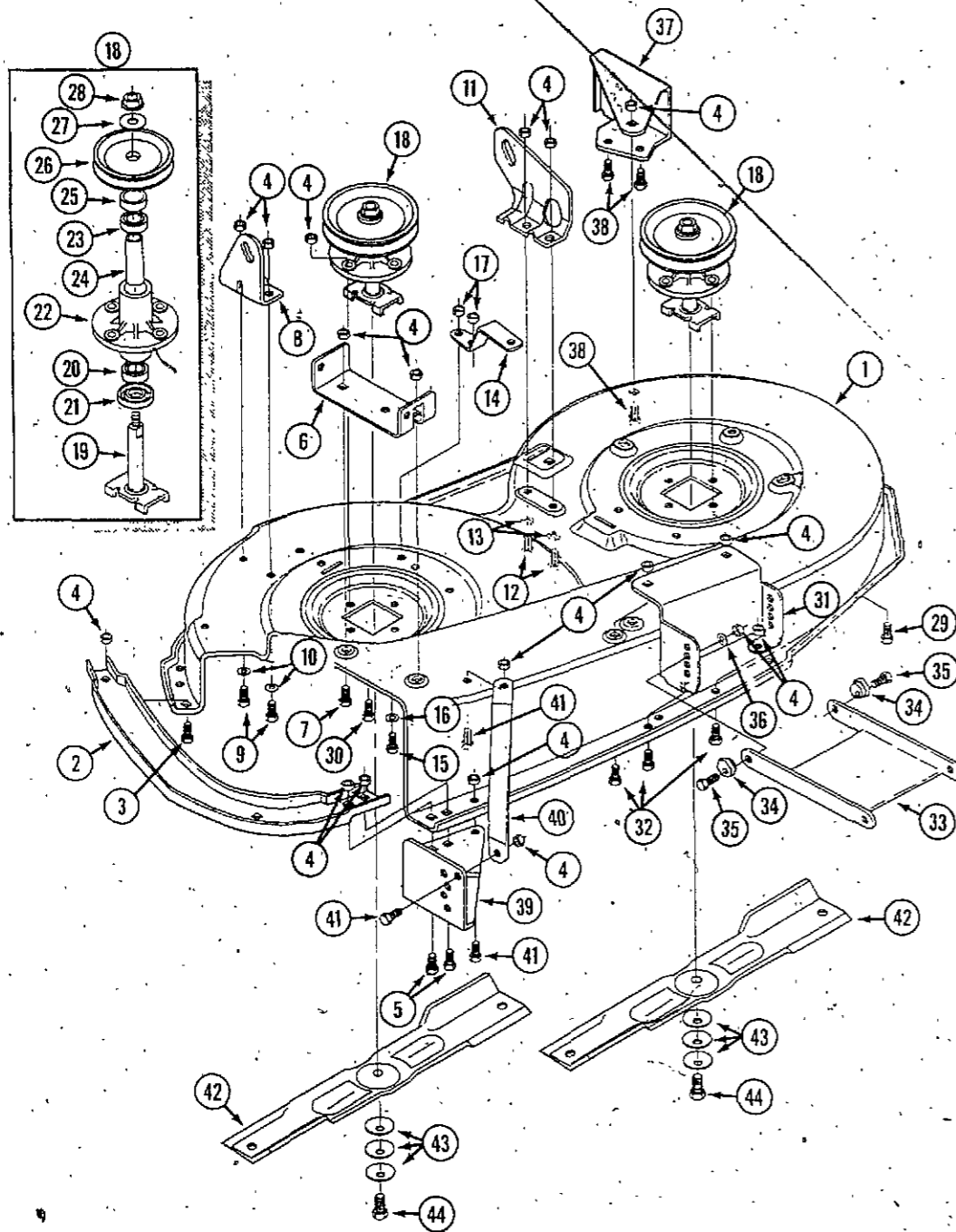

REF.	PART NO.	DESCRIPTION	REQ'D
1	C 35293	DECK - mower	1
2	C 35294	GUARD - toe	1
3	113- 118	SCREW - 5/16" - 18 x .63"	1
4	113- 176	NUT - 5/16" - 18 lock	22
5	113- 102	SCREW - 5/16" - 18 x .75"	2
6	C 35296	BRACKET - chute mount	1
7	113- 118	SCREW - 5/16" - 18 x .63"	2
8	C 35297	BRACKET - lift, rear, R.H.	1
9	113- 102	SCREW - 5/16" - 18 x .75"	2
10	195- 521	WASHER - flat .344" x .69" x .065"	2
11	C 35298	BRACKET - deck lift, rear L.H.	1
12	113- 102	SCREW - 5/16" - 18 x .75"	2
13	195- 521	WASHER - flat .344" x .69" x .065"	2
14	C 35299	BRACE - idler	1
15	113- 102	SCREW - 5/16" - 18 x .75"	2
16	195- 521	WASHER - flat .344" x .69" x .065"	2
17	131- 911	NUT - 5/16" - 18 lock	2
18	C 35300	HOUSING ASSEMBLY - spindle	1
19	C 35301	SHAFT - spindle	1
20	C 34983	BEARING - ball	1
21	C 34985	SHIELD - dust	1
22	C 35302	HOUSING - spindle	1
23	C 34983	BEARING - ball	1
24	C 35303	SPACER - 3.797" LG x .669" ID x .88" OD	1
25	C 35304	SPACER - .438" LG x .932" OD x .672" ID	1
26	C 34989	PULLEY - spindle	1
27	C 34990	WASHER - special	1
28	C 34991	NUT - 7/16" - 20 lock	1
29	C 34992	SCREW - 5/16" - 18 x .88" tap	7
30	C 35307	SCREW - 5/16" - 18 x 1.38"	1
31	C 35308	BRACKET - front	1
32	113- 118	SCREW - 5/16" - 18 x .63"	4
33	C 35309	BRACKET - deck link	1
34	C 35139	NUT - adjusting	2
35	113- 103	SCREW - 5/16" - 18 x 1.00"	2
36	195- 103	WASHER - flat .328" x 1.06" x .062"	2
37	C 35312	BRACKET - gage wheel L.H.	1
38	113- 118	SCREW - 5/16" - 18 x .63"	3
39	C 35313	BRACKET - gage wheel R.H.	1
40	C 35314	BRACKET - stabilizer	1
41	113- 118	SCREW - 5/16" - 18 x .63"	3
42	C 35315	BLADE - 21.70" high-lift	2
43	C 34997	WASHER - .39" ID x 1.25" OD x .07" bellville	6
44	C 34998	SCREW - 3/8" - 24 x 1.00" lock	2

FINAL DECK ASSEMBLY

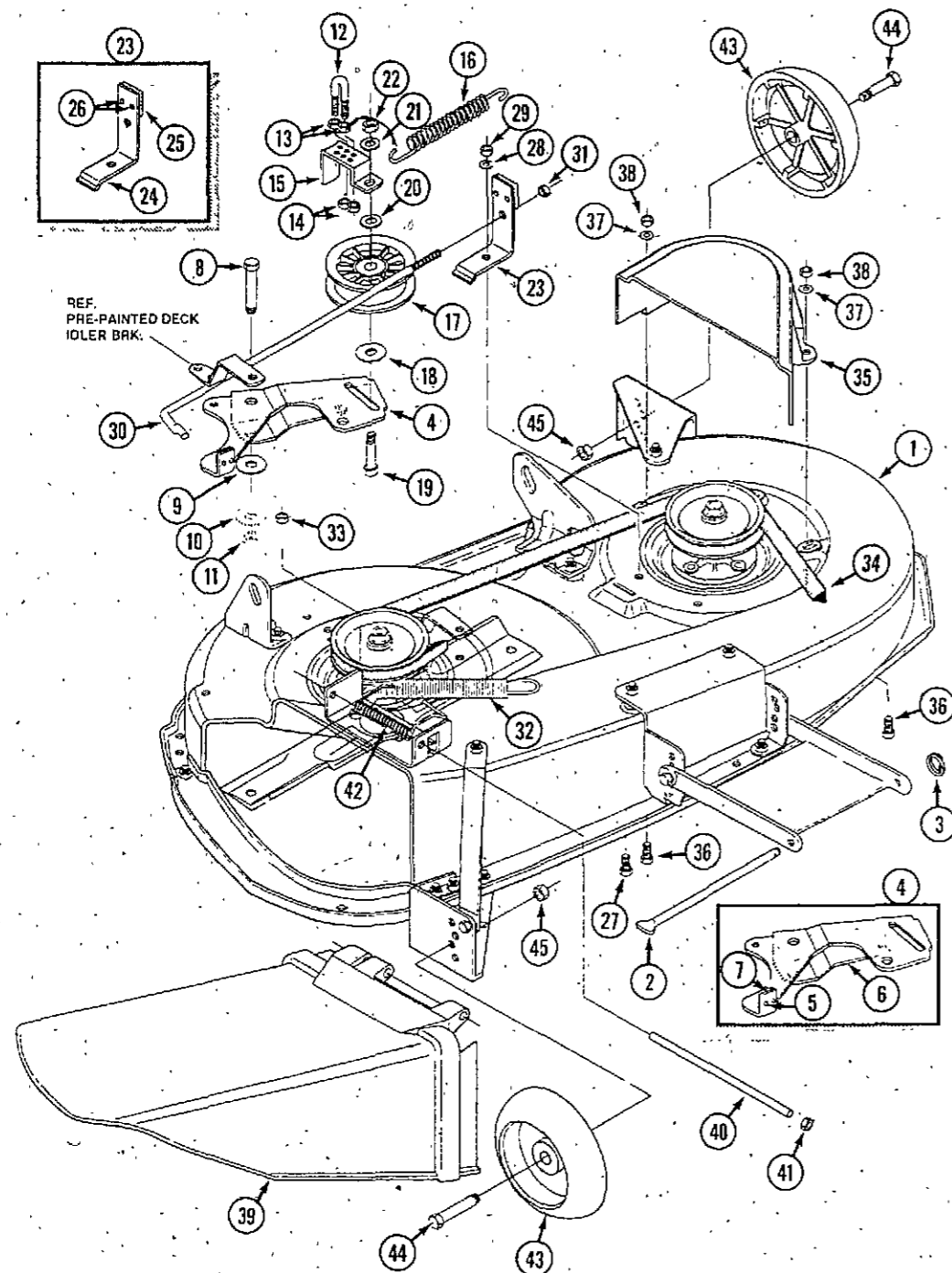

REF.	PART NO.	DESCRIPTION	REQ'D
1	NSS	DECK ASSEMBLY - order individual parts	1
2	C 35316	ROD - deck hitch	1
3	C 28105	RING - retaining	1
4	C 35317	ARM ASSEMBLY - idler	1
5	C 34953	RIVET - .187" DIA x .50 LG	2
6	NSS	ARM IDLER (not service part, order ref. 4)	1
7	C 34951	PAD - brake	1
8	C 35318	BOLT - .500" x 2.15"	1
9	C 35319	WASHER - flat .391" x 1.00" x .209"	1
10	C 35240	WASHER - flat .391" x 1.00" x .125"	1
11	131- 911	NUT - 3/8" - 16 flange lock	1
12	C 35320	BOLT - "U"	1
13	C 35290	NUT - #10-24	2
14	C 35322	NUT - #10-24 lock	2
15	C 35323	GUIDE - belt, idler	1
16	C 35324	SPRING - tension 5.00" LG	1
17	C 35458	PULLEY - idler 4.00"	1
18	C 35326	WASHER - flat .392" x 1.25" x .09"	1
19	C 35327	BOLT - 3/8" - 16 x 2.00" carriage	1
20	C 35319	WASHER - flat .391" x 1.00" x 1.25"	1
21	192- 21	WASHER - lock 3/8"	1
22	129- 103	NUT - 3/8" - 16	1
23	C 35328	BRAKE ASSEMBLY - blade	1
24	NSS	BRAKE ARM (not service part, order ref. 23)	1
25	C 34951	PAD - brake	1
26	C 34950	RIVET	2
27	113- 118	SCREW - 5/16" - 18 x .63"	1
28	195- 521	WASHER - flat .344" x .69" x .065"	1
29	131- 176	NUT - 5/16" - 18 lock	1
30	C 35329	ROD - brake	1
31	131- 1180	NUT - 1/4" - 20 lock	1
32	C 34901	SPRING - .071" x .62" x 4.37"	1
33	131- 176	NUT - 5/16" - 18 lock	1
34	C 35330	BELT - V 5L 86.00"	1
35	C 35331	GUARD - belt LH Plastic	1
36	113- 118	SCREW - 5/16" - 18 x .63"	3
37	195- 521	WASHER - flat .344" x .69" x .065"	3
38	131- 176	NUT - 5/16" - 18 lock	3
39	C 35372	CHUTE	1
40	C 35370	ROD - pivot	1
41	C 35371	NUT - push	2
42	C 34839	SPRING - torsion	1
43	C 35373	WHEEL - deck	2
44	C 34828	BOLT - shoulder 1/2" x 1-3/8", 3/8" - 16 thread	2
45	C 34814	NUT - 3/8" - 16 lock	2

ELECTRICAL ASSEMBLY

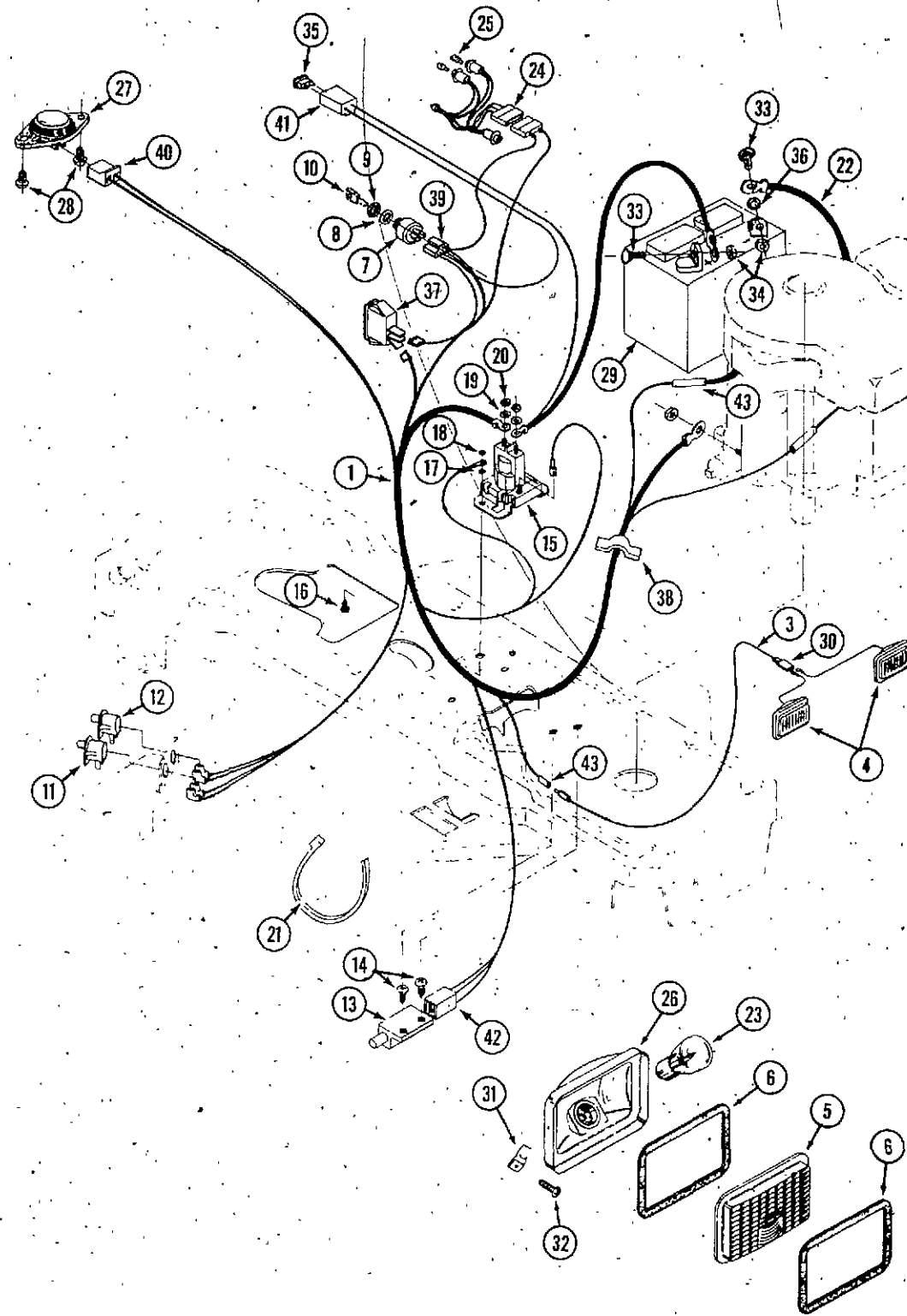

REF.	PART NO.	DESCRIPTION	REQ'D
1	C 35332	HARNES - wire	1
2	C 35030	CLIP - 1.38" LG .255" ID press wire	2
3	C 42490	ASSY - light wire	1
4	C 32178	HEADLIGHT	2
5	C 22573	LENS - headlight	2
6	C 14304	GASKET - headlight	4
7	C 32405	SWITCH - ignition & lights	1
8	193- 63	WASHER - .640 x 1.1" x .05" lock	1
9	C 32396	NUT - 5/8" - 32	1
9	C 32397	CAP - nut	1
10	C 32407	KEY - ignition switch	1
11	C 37298	SWITCH - N.O.	1
12	C 33744	SWITCH - N.C.	1
13	C 35340	SWITCH - N.C.	1
14	C 35016	SCREW - #12 x .50" tap	2
15	C 35022	SOLENOID	1
16	113- 3	SCREW - 1/4" - 20 x .75"	2
17	131- 1102	NUT - 1/4" - 20 lock	3
18	129- 101	NUT - 1/4" - 20	1
19	192- 20	WASHER - 5/16" lock	2
20	129- 122	NUT - 5/16" - 24	2
21	C 22947	TIE - cable, nylon	1
22	C 35033	WIRE - ground; - 12.5"	1
23	C 28932	BULB - headlight	2
24	C 35468	HARNES - light	1
25	C 35343	BULB - indicator	2
26	NSS	RECEPTACLE - headlight (use C32178)	2
27	C 30938	SWITCH - seat	1
28	C 35346	SCREW - 1/4" - 20 x .38"	2
29	C 41010	BATTERY - 12 volt	1
30	C 14537	CONNECTOR - wire	1
31	131- 629	NUT - speed	4
32	187- 1334	SCREW - #8 x 1/2"	4
33	113- 3	BOLT - 1/4" - 20 x 3/4"	2
34	131- 934	NUT - 1/4" - 20 flange lock	2
35	C 35036	FUSE - 15 amp spade type	1
36	195- 518	WASHER - 1/4"	4
37	C 29322	SWITCH - headlight	1
38	C 35030	CLIP - wire	1
39	C 24460	BODY - connector	1
40	C 30937	BODY - connector	1
41	C 30261	BODY - fuse	1
42	C 25243	BODY - connector	1
43	C 42871	BODY - connector	2

UAR

DECALS

REF.	PART NO.	DESCRIPTION	REQ'D
1	C 35050	DECAL - no step	2
2	C 31087	DECAL - cut-hand warning label	1
3	C 30539	MEDALLION	3
4	C 37078	DECAL - hood side R.H.	1
5	C 37077	DECAL - hood side L.H.	1
6	C 35354	DECAL - dash L.H. blank	1
7	C 35355	DECAL - dash R.H. ISO	1
8	C 35356	DECAL - dash R.H. Ign. w/o lights	1
9	C 35357	DECAL - center, instruct.	1
10	C 35472	DECAL - dash L.H. throttle	1
11	C 42473	DECAL - caution, console top LF	1
12	C 34184	DECAL - flag	1
13	C 42451	DECAL - PTO	1
14	C 37197	DECAL - steering wheel	1
15	C 35362	DECAL - lift, deck blade height	1
16	C 35363	DECAL - shift rev/neutral	1
17	C 35365	DECAL - shifter position	1
18	C 35052	NAMEPLATE - Ingersoll	1

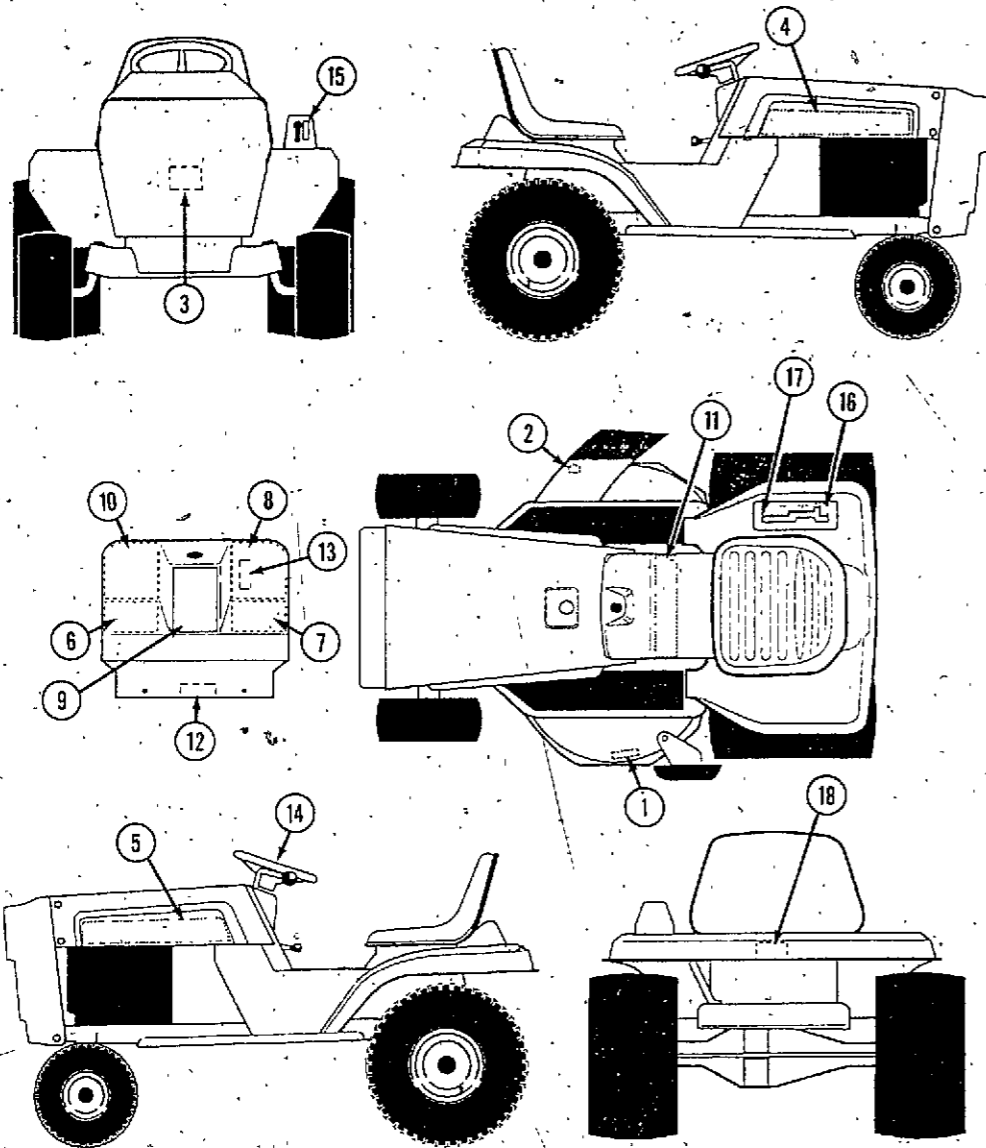

LAWN TRACTOR MODEL 1214
C40667 TRANSAXLE ASSEMBLY

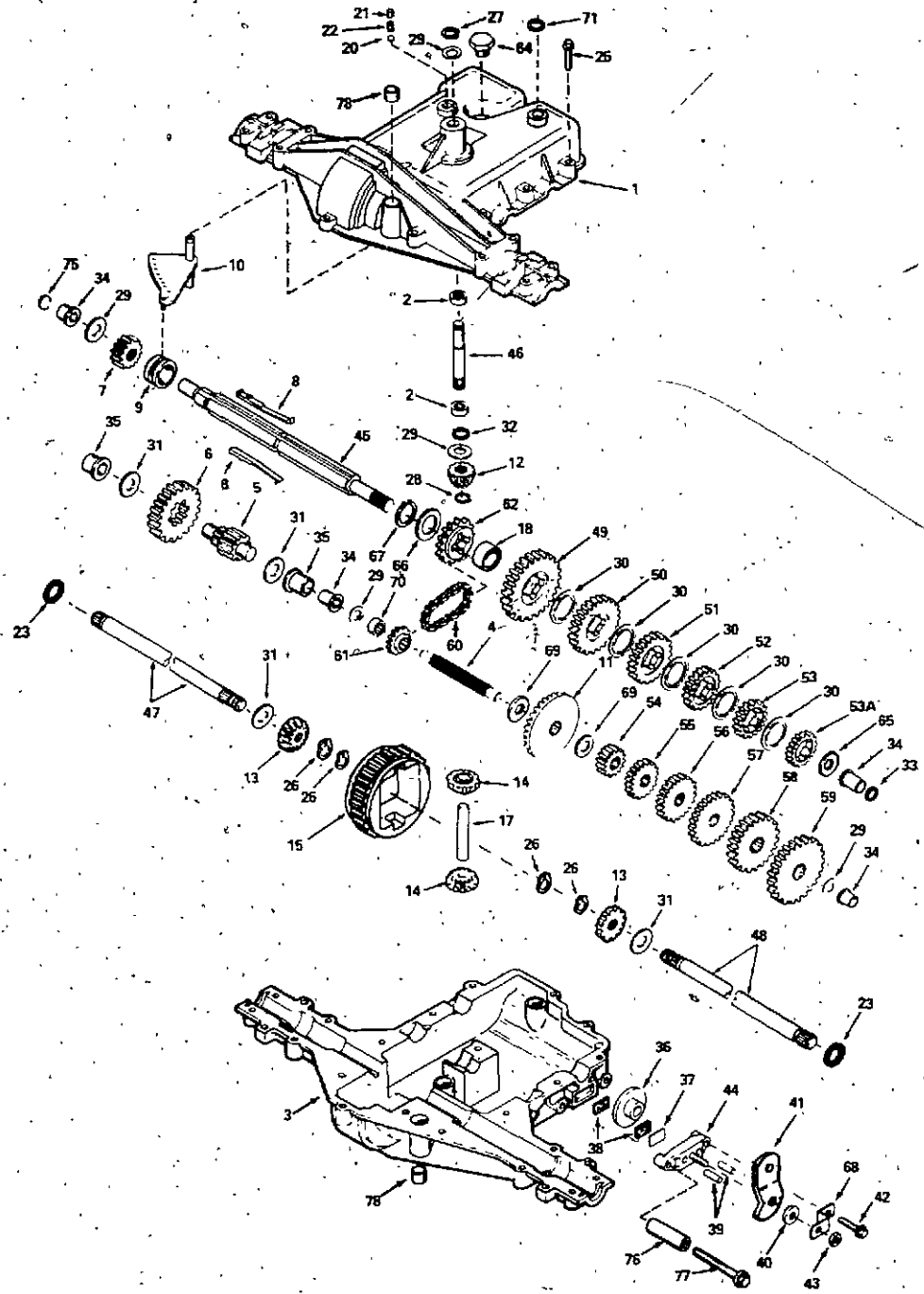

REF.	PART NO.	DESCRIPTION	REQ'D
1	C 34486	COVER - transaxle	1
2	C 28649	BEARING - needle	2
3	C 34487	CASE - transaxle	1
4	C 34488	SHAFT - counter	1
5	C 34489	SHAFT & PINION ASSY - output	1
6	C 27562	GEAR - output	1
7	C 27553	GEAR - spur 15T	1
8	C 34490	KEY	4
9	C 34491	COLLAR - shifter	1
10	C 34492	ROD & FORK ASSY - shift	1
11	C 34493	GEAR - bevel 42T	1
12	C 28652	GEAR - bevel pinion, input	1
13	C 30500	GEAR - bevel	2
14	C 19310	GEAR - bevel pinion	2
15	C 34494	GEAR - ring	1
17	C 34495	PIN - drive	1
18	C 34496	SPACER	1
20	C 28667	BALL - steel 5/16" DIA.	1
21	C 34148	SCREW - set 3/8" - 16 x 3/8"	1
22	C 28654	SPRING	1
23	C 34497	RING - seal	2
25	C 34147	SCREW - 1/4" - 20 x 1-1/4" flange, tapping	17
26	C 34156	RING - retainer (pkg. of 2)	4
27	C 19347	RING - retainer	1
28	C 19352	RING - retainer	1
29	C 19345	WASHER - thrust	5
30	C 28664	WASHER - thrust	5
31	C 11205	WASHER	4
32	C 28648	"O" RING	1
33	C 27570	SEAL - square cut	1
34	C 28653	BUSHING - flanged	4
35	C 27565	BUSHING - flanged	2
36	C 27563	DISK - brake	1
37	C 19354	PLATE - brake pad	1
38	C 19353	PAD - brake	2
39	C 28650	PIN - dowel	2
40	C 19357	WASHER - flat	1
41	C 34498	LEVER - brake	1
42	C 34147	SCREW - 1/4" - 20 x 1-1/4" flange, self tapping	1
43	C 19358	NUT - lock 5/16" - 24	1
44	C 34144	HOLDER - brake pad	1
45	C 34499	SHAFT - brake	1
46	C 28651	SHAFT - input	1
47	C 34500	AXLE - 10" long	1
48	C 34501	AXLE - 14 - 19/32" long	1
49	C 34502	GEAR - spur 37T	1
50	C 28658	GEAR - spur 30T	1
51	C 34503	GEAR - spur 27T	1
52	C 28657	GEAR - spur 25T	1
53	C 27555	GEAR - spur 22T	1
53A	C 28656	GEAR - spur 20T	1
54	C 34504	GEAR - spur 12T	1
55	C 28660	GEAR - spur 20T	1
56	C 34505	GEAR - spur 32T	1
57	C 28661	GEAR - spur 25T	1
58	C 27556	GEAR - spur 28T	1
59	C 28662	GEAR - spur 30T	1
60	C 34506	CHAIN - roller No. 41, 22 links	1
61	C 34507	SPROCKET - 10T	1
62	C 34508	SPROCKET - 14T	1
64	C 27588	PLUG - hex hd. 9/16" - 18	1
65	C 28663	WASHER - thrust	1
66	C 34509	WASHER - thrust	1
67	C 34510	RING - retaining	1
68	C 28821	BRACKET - brake lever	1
69	C 34511	WASHER - thrust	2
70	C 34512	SPACER	1
71	C 34149	SEAL - square cut	1
75	C 34513	DISK	1
76	C 34514	SPACER	1
77	C 34515	SCREW - 1/4" - 20 x 2-1/4" flange, tapping	1
78	C 19316	BEARING - bronze	2

FLYWHEEL, CRANKSHAFT, CAMSHAFT AND PISTON

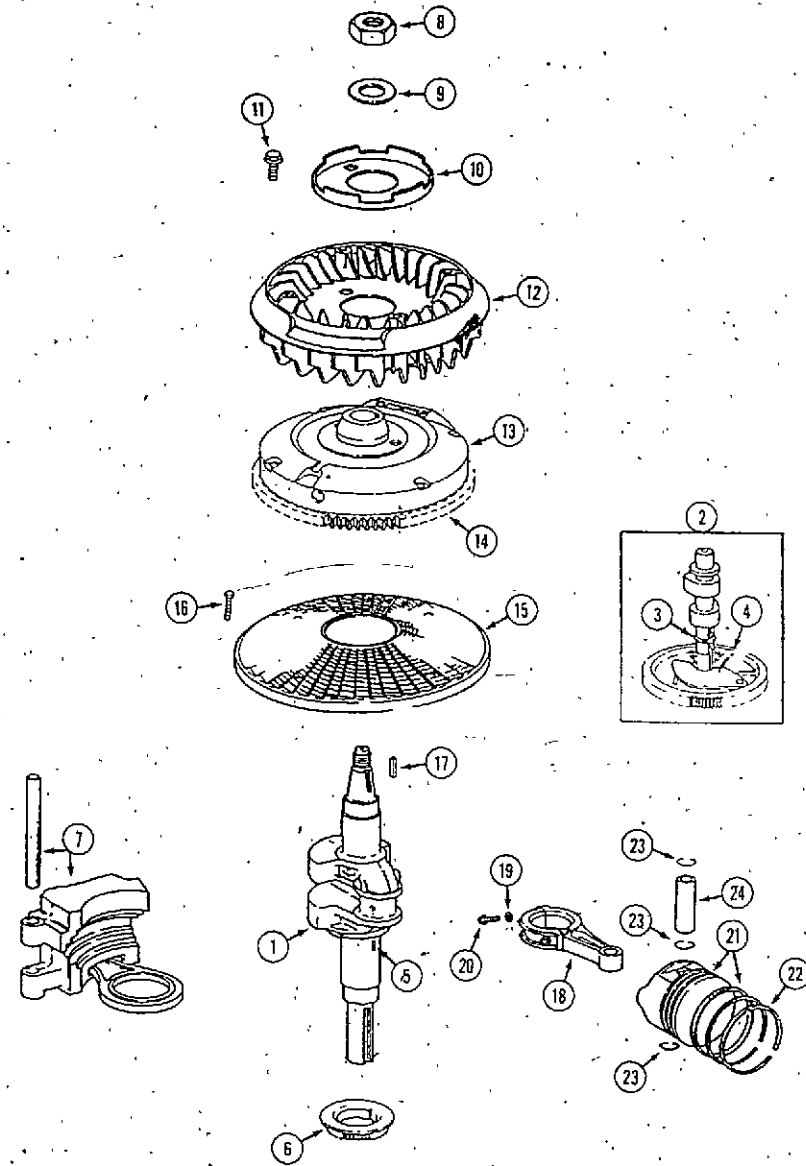

REF.	PART NO.	DESCRIPTION	REQ'D
1	C 40888	CRANKSHAFT	1
2	C 40888	CAMSHAFT AND GEAR	1
3	C 40889	RING - retaining	1
4	C 40889	SPRING - cam release	1
5	C 34598	KEY - timing gear	1
6	C 40760	GEAR - timing	1
7	C 40761	COUNTERWEIGHT ASSEMBLY	1
8	C 34671	NUT - flywheel	1
9	C 34619	WASHER - spring	1
10	C 30448	RETAINER - fan	1
11	C 34641	SCREW - fan mounting	3
12	C 40780	FAN - flywheel	1
13	C 34602	FLYWHEEL AND RING GEAR	1
14	C 40756	GEAR - ring	1
15	C 34681	SCREEN	1
16	C 34620	SCREW - screen	UAR
17	C 27236	KEY - flywheel	1
18	C 34608	ROD - connecting (standard)	1
18	C 34609	ROD - connecting .020" undersize	1
19	C 34610	WASHER - connecting rod	1
20	C 34611	SCREW - connecting rod	1
21	C 34583	PISTON ASSEMBLY - standard	1
21	C 34586	PISTON ASSEMBLY - .010" oversize	1
21	C 34587	PISTON ASSEMBLY - .020" oversize	1
21	C 34589	PISTON ASSEMBLY - .030" oversize	1
22	C 34593	RING SET - standard	1
22	C 34603	RING SET - .010" oversize	1
22	C 34604	RING SET - .020" oversize	1
22	C 34605	RING SET - .030" oversize	1
23	C 34606	LOCK - piston pin	2
24	C 34607	PIN - piston (includes ref. 21)	1

CYLINDER BLOCK, CYLINDER HEAD AND CRANKCASE

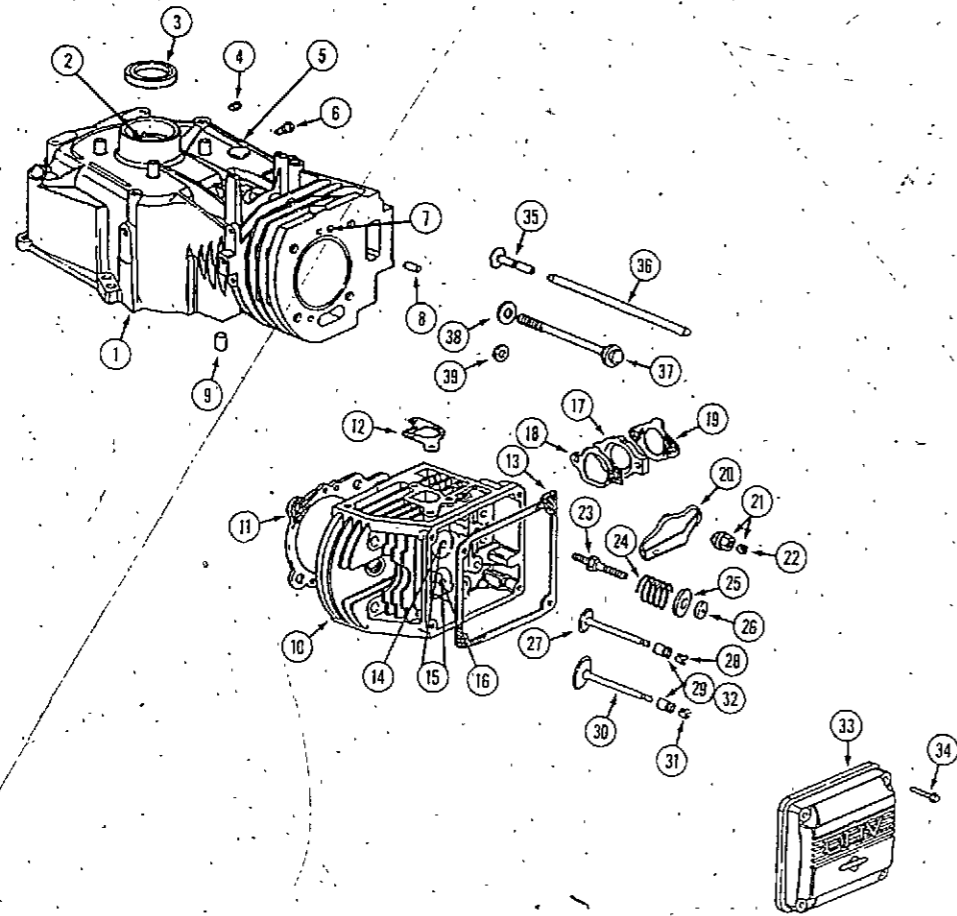

REF.	PART NO.	DESCRIPTION	REQ'D
1	C 34581	CYLINDER ASSEMBLY	1
2	C 34582	BEARING - cylinder	1
3	NSS	SEAL - oil (see gasket kit)	1
4	C 34621	PLUG - pipe	1
5	C 34640	BUSHING - governor crank	1
6	C 34596	PLUG - oil hole	1
7	C 34663	VALVE - pressure relief	1
8	C 40753	PIN - cylinder	1
9	C 40752	PIN - cylinder	1
10	C 34584	HEAD ASSEMBLY - cylinder	1
11	NSS	GASKET - cylinder head (see gasket kit)	1
12	C 40773	GASKET - exhaust (also see gasket kit)	1
13	NSS	GASKET - rocker arm cover (see gasket kit)	1
14	C 40769	SEAT - exhaust valve	1
15	C 40770	BUSHING - valve guide	2
16	C 40768	SEAT - intake valve	1
17	C 34629	ADAPTER - carburetor mounting	1
18	NSS	GASKET - intake (also see gasket kit)	1
19	NSS	GASKET - carburetor (also see gasket kit)	1
20	C 40788	ARM - rocker	2
21	C 34644	NUT - rocker arm	2
22	NSS	SCREW - set	1
23	C 34636	STUD - rocker arm	2
24	C 34614	SPRING - valve	2
25	C 34615	RETAINER - intake valve	1
26	C 34660	CAP - valve	2
27	C 34612	VALVE - exhaust	1
28	C 34616	RETAINER - valve rotocoil (one pair)	1
29	NSS	SEAL - valve stem (also see gasket kit)	1
30	C 34613	VALVE - intake	1
31	C 34616	RETAINER - valve rotocoil (one pair)	1
32	NSS	SEAL - valve stem (also see gasket kit)	1
33	C 40783	COVER - valve	1
34	C 34590	SCREW - valve cover	4
35	C 34617	TAPPET - valve	2
36	C 40785	PUSHROD - exhaust	1
36	C 40786	PUSHROD - intake	1
37	C 34594	SCREW - cylinder head	4
38	C 34585	WASHER - cylinder head	4
39	C 34601	WASHER AND SEAL	4

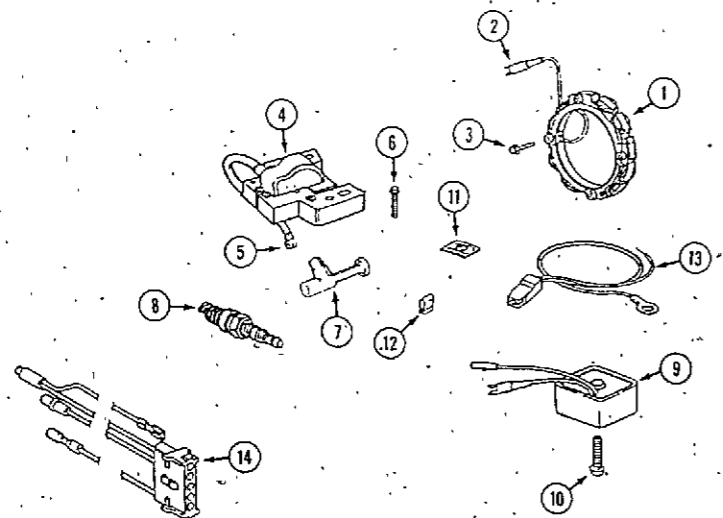
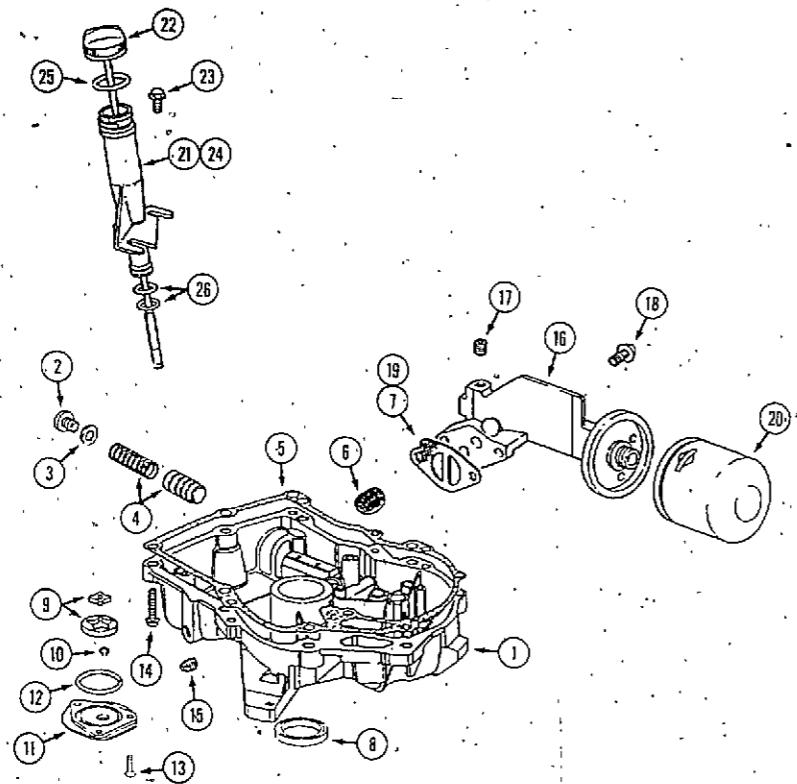

ENGINE BASE, DIPSTICK AND OIL FILTER

REF.	PART NO.	DESCRIPTION	REQ'D
1	C 34599	BASE - engine	1
2	C 34621	PLUG - relief	1
3	NSS	WASHER - relief plug	1
4	C 34664	VALVE - pressure relief	1
5	NSS	GASKET - base (1/64" thick) (also see gasket kit)	1
6	C 34662	SCREEN - oil pump	1
7	NSS	GASKET - oil filter adapter (also see gasket kit)	1
8	NSS	SEAL - oil (also see gasket kit)	1
9	C 40784	OIL PUMP	1
10	C 40746	RING - retaining (governor gear)	1
11	C 40778	COVER - oil pump	1
12	NSS	"O" RING - cover (also see gasket kit)	1
13	C 40763	SCREW - oil pump cover	3
14	C 34600	SCREW - base	UAR
15	C 34595	PLUG - oil drain	1
16	C 40787	ADAPTER - oil filter	1
17	C 34623	PLUG - pipe	1
18	C 40779	SCREW - oil filter adapter	2
19	NSS	GASKET - oil filter adapter (also see gasket kit)	1
20	C 34374	FILTER - oil	1
21	C 40766	DIPSTICK AND TUBE	1
22	NSS	DIPSTICK - oil filler	1
23	C 34667	SCREW - oil fill tube	2
24	NSS	TUBE - oil filler	1
25	BR270920	SEAL - dipstick	1
26	C 34686	SEAL - filler tube	2

IGNITION AND CHARGING SYSTEM

1	C 34682	STATOR - alternator	1
2	C 40772	CONNECTOR - stator	1
3	C 34683	SCREW - stator	1
4	C 34289	ARMATURE - magneto	1
5	BR221798	TERMINAL - ignition cable	1
6	C 34672	SCREW - armature	2
7	C 40750	BOOT - spark plug	1
8	C 34291	SPARK PLUG	1
9	C 34684	REGULATOR - rectifier (9 amp)	1
10	C 34687	SCREW - regulator	1
11	C 40758	CLIP - wire	UAR
12	C 40759	CLIP - wire	UAR
13	C 29796	WIRE - ground	1
14	C 40762	HARNESS - wire	1

CARBURETOR

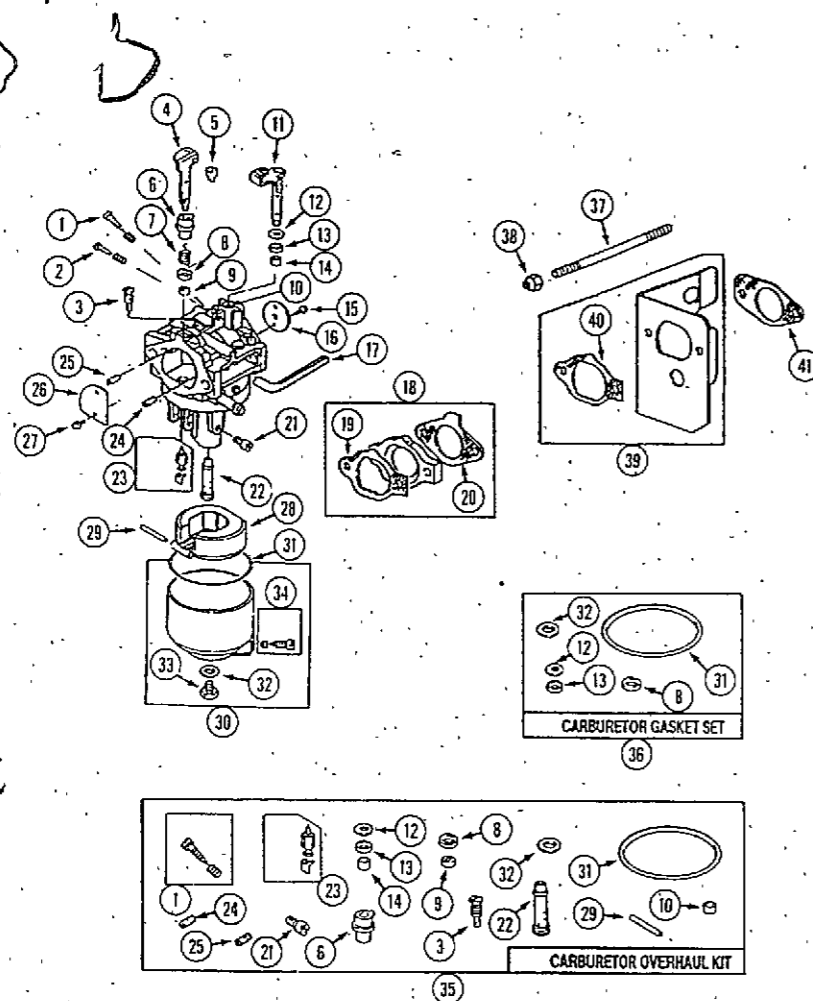

REF.	PART NO.	DESCRIPTION	REQ'D
	C 34630	CARBURETOR	1
1	NSS	VALVE - idle (see overhaul kit)	1
2	C 34626	SCREW AND SPRING - idle adjust	1
3	NSS	NOZZLE - (see overhaul kit)	1
4	C 34634	SHAFT ASSEMBLY - choke	1
5	C 40782	RETAINER - link	1
6	NSS	RETAINER - choke shaft (upper) (also see overhaul kit)	1
7	NSS	SPRING - choke shaft	1
8	NSS	SEAL - choke shaft (also see overhaul kit)	1
9	NSS	RETAINER - choke shaft (lower) (also see overhaul kit)	1
10	NSS	BUSHING - throttle shaft (upper) (see overhaul kit)	1
11	C 34632	SHAFT ASSEMBLY - throttle	1
12	NSS	SEAL - throttle shaft (also see overhaul kit)	1
13	NSS	SEAL - throttle shaft (also see overhaul kit)	1
14	NSS	BUSHING - throttle shaft (lower) (also see overhaul kit)	1
15	C 34625	SCREW - throttle valve	2
16	C 34631	VALVE - throttle	1
17	C 40781	TUBE - bowl vent	1
18	C 34629	ADAPTER - carburetor mounting	1
19	NSS	GASKET - intake	1
20	NSS	GASKET - carburetor	1
21	NSS	JET - main fuel (see overhaul kit)	1
22	NSS	NOZZLE (see overhaul kit)	1
23	NSS	VALVE - fuel inlet	1
24	NSS	NOZZLE (see overhaul kit)	1
25	NSS	NOZZLE (see overhaul kit)	1
26	C 34627	VALVE - choke	1
27	C 34624	SCREW - choke valve mounting	1
28	C 34633	FLOAT - carburetor	1
29	NSS	PIN - float hinge (also see overhaul kit)	1
30	C 40776	BOWL - carburetor	1
31	NSS	GASKET - carburetor bowl (also see gasket kit)	1
32	NSS	GASKET - sealing (also see gasket kit)	1
33	NSS	SCREW - bowl mounting	1
34	NSS	DRAIN - bowl	1
35	C 34628	KIT - carburetor overhaul	1
36	C 40777	KIT - carburetor gasket	1
37	C 34637	STUD - carburetor	2
38	C 34639	NUT - carburetor stud	2
39	C 40755	SHIELD - heat	1
40	NSS	GASKET - intake (see main gasket kit)	1
41	C 40802	GASKET - carburetor mounting	1

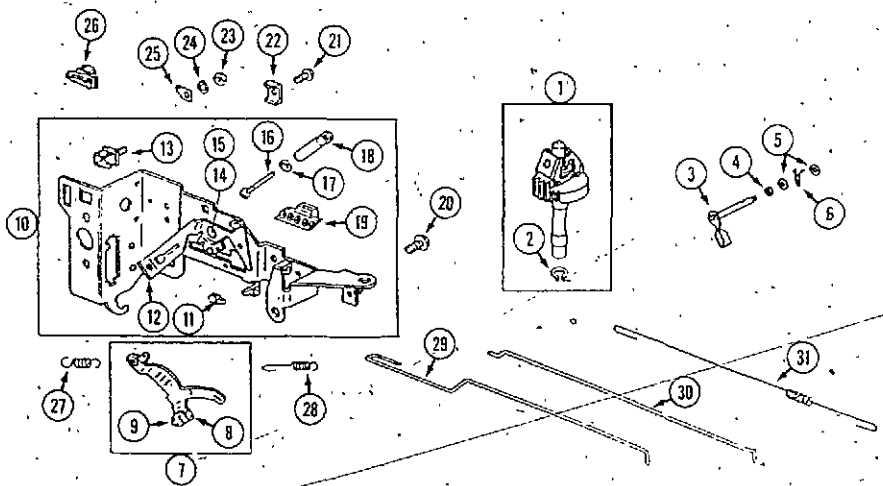
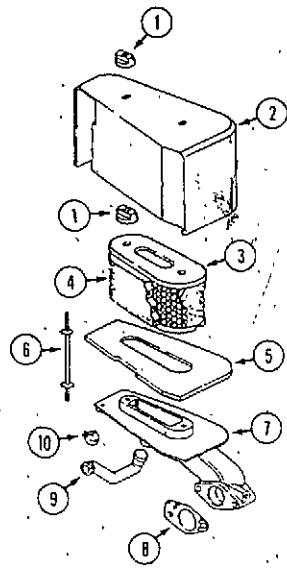

AIR CLEANER

REF.	PART NO.	DESCRIPTION	REQ'D
1	C 34680	KNOB - air cleaner	4
2	C 40771	COVER - air cleaner	1
3	C 34679	CARTRIDGE - air cleaner	1
4	C 34688	PRECLEANER	1
5	C 34689	GASKET - air cleaner	1
6	C 34638	STUD - air cleaner	2
7	C 34635	MAINIFOLD - intake	1
8	C 40802	GASKET - mounting	1
9	C 34592	TUBE - breather	1
10	C 40743	CLAMP - breather	1

GOVERNOR

1	C 34653	GEAR - governor	1
2	C 40746	RING - retaining, governor gear	1
3	C 40749	CRANK - governor	1
4	C 40803	SEAL - governor crank	1
5	C 34658	WASHER - governor crank	2
6	C 40745	PIN - cotter	1
7	C 34657	LEVER - governor	1
8	C 34661	BOLT	1
9	C 40742	NUT	1
10	C 34654	BRACKET - governor control	1
11	C 40782	RETAINER - link	1
12	C 34655	LEVER - governor control bracket	1
13	C 29794	INSULATOR	1
14	C 34656	RIVET	1
15	C 34646	LEVER - speed control	1
16	C 34648	SCREW	1
17	C 40747	RING - retaining	1
18	C 34647	ADJUSTER - control rod	1
19	C 40775	GEAR - rack	1
20	C 34277	SCREW	1
21	C 40751	SCREW	1
22	BR221535	CLAMP - casing	1
23	C 34676	NUT	1
24	C 34675	LOCKWASHER	1
25	C 34685	TERMINAL - spade	1
26	NSS	SWITCH - stop	1
27	C 40890	SPRING - governor	1
28	C 34650	SPRING - idler	1
29	C 34652	LINK - choke	1
30	C 34645	LINK - governor	1
31	C 34659	SPRING - governor link	1

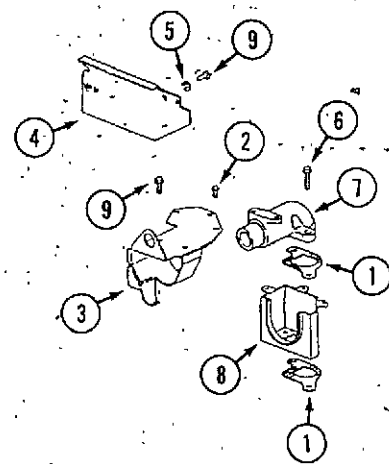
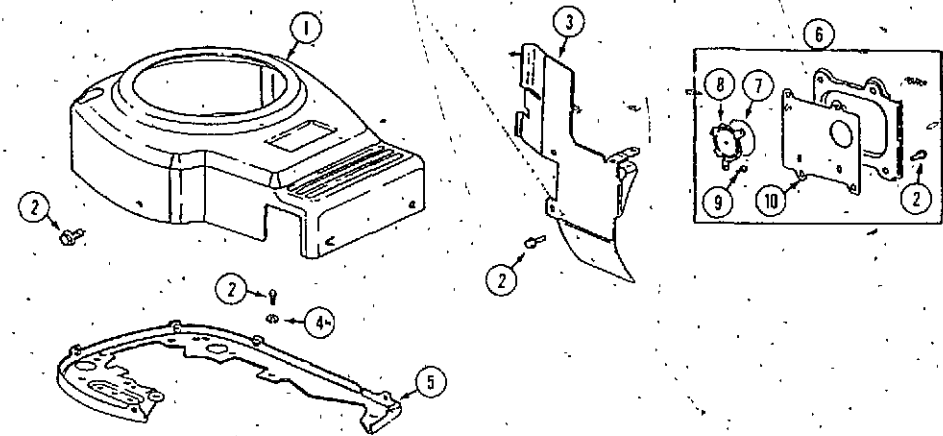

ENGINE AIR BAFFLES AND BREATHER

REF.	PART NO.	DESCRIPTION	REQ'D
1	C 34669	HOUSING - blower	1
2	C 34277	SCREW	UAR
3	C 34670	SHIELD - cylinder	1
4	C 34642	LOCKWASHER	UAR
5	C 40741	PLATE - back	1
6	C 34588	BREATHER ASSEMBLY	1
7	NSS	DISC - valve	1
8	NSS	RETAINER	1
9	C 34591	SCREW	4
10	NSS	GASKET - valve cover (also see main gasket kit)	1

EXHAUST SYSTEM

1	C 40773	GASKET - exhaust	1
2	C 34673	SCREW	UAR
3	C 40765	COVER - exhaust	1
4	C 40754	SHIELD - heat	1
5	C 34642	LOCKWASHER	UAR
6	C 40744	SCREW	2
7	C 34678	ELBOW - exhaust	1
8	C 40764	GUARD - exhaust elbow	1
9	C 34277	SCREW	UAR

STARTER

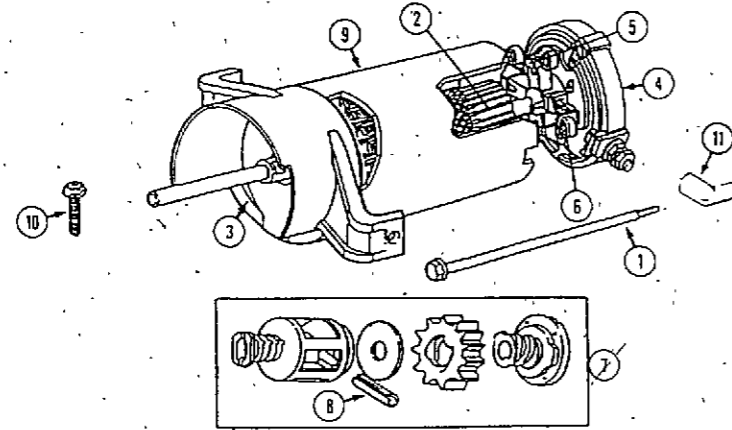

REF.	PART NO.	DESCRIPTION	REQ'D
	C 40798	STARTER ASSEMBLY	1
1	C 34285	BOLT - thru	2
2	C 40800	ARMATURE	1
3	C 40801	END CAP - drive end	1
4	C 34336	END CAP - commutator end	1
5	C 34286	BRUSH ASSEMBLY	4
6	C 34364	SPRING - brush	4
7	C 40799	DRIVE ASSEMBLY	1
8	138- 75	PIN - roll	1
9	C 34337	HOUSING - starter	1
10	C 40757	SCREW - mounting	2
11	C 31618	COVER - terminal	1

GASKET KIT

1	NSS	GASKET - cylinder head	1
2	BR270920	SEAL - oil fill cap	1
3	C 34686	SEAL - oil filler tube	2
4	NSS	GASKET - oil filter adapter	1
5	NSS	GASKET - intake	1
6	NSS	GASKET - rocker arm cover	1
7	NSS	GASKET - carburetor	1
8	NSS	GASKET - valve cover	1
9	C 40802	GASKET - carburetor mounting	1
10	NSS	SEAL - oil	2
11	NSS	"O" RING - oil pump cover	1
12	NSS	GASKET - crankcase cover (1/64" thick)	1
13	C 34601	WASHER - seal, cylinder head	4
14	C 40803	SEAL - governor crank	1
15	C 40773	GASKET - exhaust	2
16	NSS	SEAL - valve stem	2

