

**COMPACT TRACTOR  
1114 AWS  
Parts Catalog 8-3180**

5-91-RP-500-227

**ALPHABETICAL INDEX**

**TRACTOR SECTION**

	<b>Page</b>	<b>Grid</b>
Chassis and Hood Assembly	5-7	A5-A8
Customer Assembly	29	C2
Decals	27	B14
Electrical Assembly	25	B12
Engine and Control Assembly	25	B12
Final Deck Assembly	23	B10
Front Wheel Steering Assembly	11	A12
Motion Drive Assembly	15-17	B2-B4
Mower Suspension Assembly	9	A10
Pre-Painted Deck Assembly	21	B8
Rear Wheel Steering Assembly	13	A14
Transaxle Assembly	31	C4

**ENGINE SECTION**

Air Cleaner	41	C14
Air Guides	43	D2
Blower Housing	43	D2
Block-Cylinder	35	C8
Breather-Crankcase	41	C14
Camshaft	33	C6
Charging System	33	C6
Carburetor	39	C12
Crankcase	37	C10
Crankshaft	33	C6
Flywheel	33	C6
Gasket Sets	45	D4
Governor	37	C10
Head-Cylinder	35	C8
Ignition	33	C6
Manifold	39	C12
Oil Filter	37	C10
Pistons	33	C6
Starter	45	D4

## GENERAL INFORMATION

### INDEX

There is an index at the front and rear of this catalog.

The front index is an alphabetical index of the major groups or assemblies.

The rear index is a numerical index of the part numbers and pages on which these numbers are shown.

### ILLUSTRATION

Each illustration in this catalog shows a group of parts or components. These parts and components are aligned approximately as the parts and components on your machine. Each part and component in an illustration has a reference number. These reference numbers are in a list on the page opposite of the illustration. Next to the reference number is the part number, description and required quantity of the part shown in the illustration.

UAR - "Use as required" indicates that the part quantity is variable.

NSS - "Not sold separately" indicates that the part is only available as a component of an assembly or the part must be purchased locally. If the part is an assembly component, the description will be indented under the assembly description in the parts list.

O/L - "Obtain locally"

\*\* - "Footnotes" are added to a part number when more information is needed for identification. They only relate to the part numbers indicated.

### PARTS ORDERS

All orders must include the following information:

1. Correct part number.
2. Complete description of part or component.
3. Total quantity of each part or component.
4. Product model number.
5. All necessary product identification numbers.
6. Method for sending the parts.
7. Complete and correct address.

### CATALOG REVISIONS

As the product changes, new pages will be available for your catalog. A notice will be issued.

**IMPORTANT:** Put all revisions into the catalog as soon as possible.

### RIGHT HAND AND LEFT HAND IDENTIFICATION

The words right hand (RH) and left hand (LH) as used in this catalog indicate the direction while you are in the operator's seat in the normal operating position.

### INDENTED DESCRIPTIONS

An assembly can have many components. The components of an assembly are indicated by an indented description. The quantity for an indented part is the total needed for that complete assembly. See the example.

REF.	PART NO.	DESCRIPTION	REQ'D
	C 55159	CYLINDER ASSY - rear steering .....	1
28	C 56208	SOCKET ASSY - rear cylinder .....	1
29	C 55956	PLUG - adjusting, socket assy .....	1
30	C 55957	SEAT - socket ball .....	2
31	C 56210	SPRING - socket .....	1
32	C 56209	SEAT - socket spring .....	1
33	G 45175	CLAMP ASSY - socket assy .....	1
	16- 836	BOLT - 1/2" x 2-1/4" N.F. hex .....	1
34	132- 104	PIN - cotter, 3/16" x 3" .....	1
35	C 55889	STUD - ball, socket & cylinder .....	2
36	13- 410	BOLT - 1/4" x 5/8" N.C., hex .....	4
37	92- 4	LOCK WASHER - 1/4" SAE .....	4

# INGERSOLL

Ingersoll Equipment Co., Inc.

CHASSIS AND HOOD ASSEMBLY

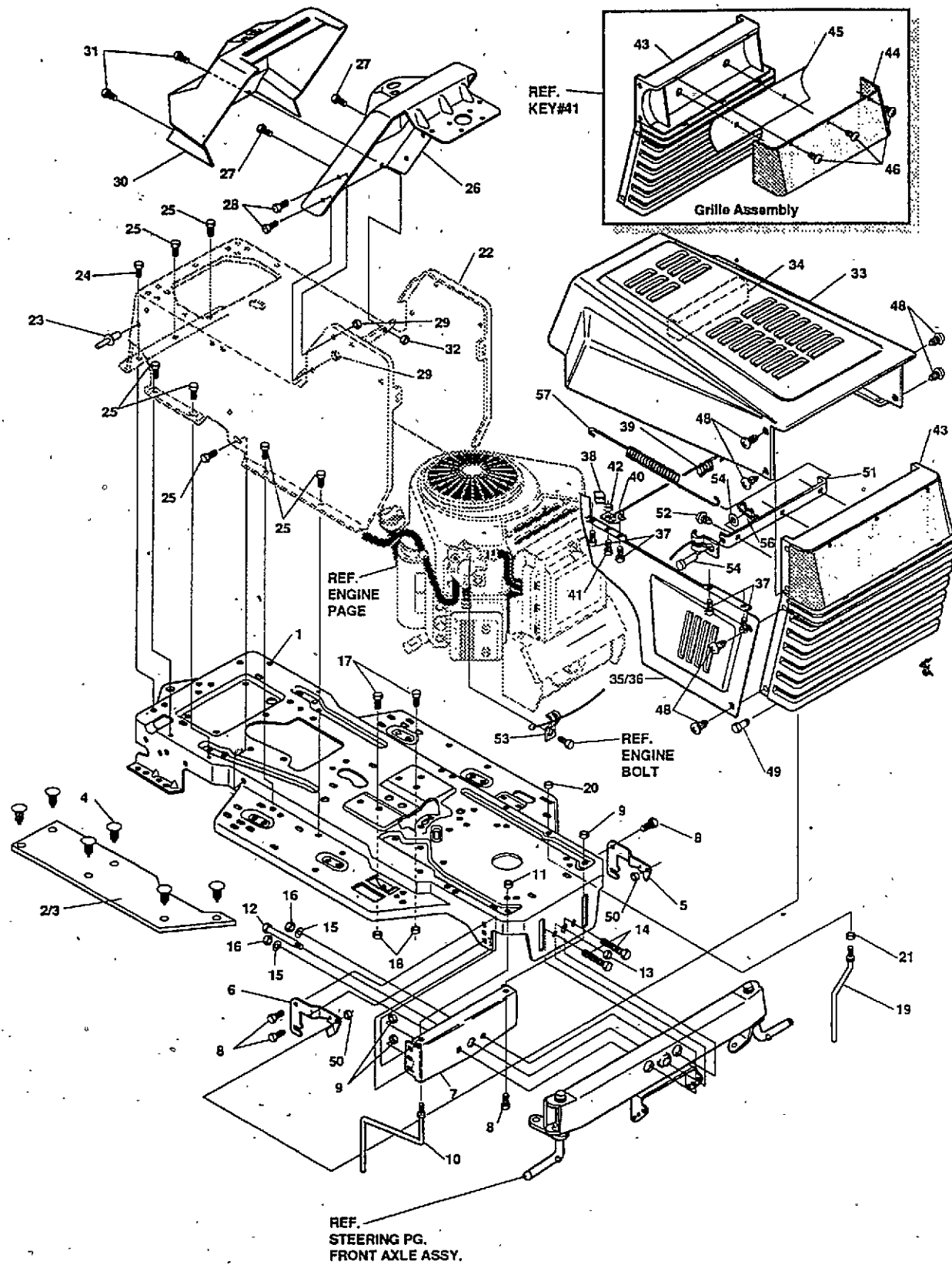

key#	part#	description	qty.
1	C35064	FRAME,LF MAIN P920/F4360	1
2	C35065	FOOTPAD,LH	1
3	C35066	FOOTPAD,RH	1
4	C35067	FASTENER, RATCHET	12
5	C35068	BRKT.GRILLE, L.H.	1
6	C35069	BRKT GRILLE R.H.	1
7	C35070	BRACKET, FRONT AXLE	1
8	C35071	SCREW, 5/16-18X.75WDFLLK GR5	5
9	C35072	NUT, 5/16-18 HXWDFLLK	5
10	C35073	GUIDE, BELT, RIDER	1
11	C34798	NUT, 5/16-18 REGHEXCTRLK	1
12	C35074	BOLT, .625X2.180 HHS 1/2-13NC	1
13	C35075	NUT, 1/2-13 REGHCTRLK	1
14	C35076	SCREW, 3/8-16X3.00 HHC GR2	2
15	C34997	WASHER, .39IDX1.25DX.07 BELLVIL	2
16	C34814	NUT, 3/8-16 REGHXCTRLK	2
17	C34817	SCREW, 5/16-18X .88 HHC GR2	2
18	C34798	NUT, 5/16-18 REGHEXCTRLK	2
19	C35077	GUIDE,BELT SHORT 15" WHEEL	1
20	C35078	NUT, 5/16-18 HEXJAM	1
21	C35079	NUT, 3/8-16 HEXKEPS	1
22	C35080	CONSOLE DYNA LF SOF P-LIFT	1
23	C35081	RIVET, POP .187DIA X .450LG ST	1
24	C34848	SCREW, 5/16-18X .50 WAHTAP	1
25	C34794	SCREW, 1/4-20X .50 WAHTAP	12
26	C35082	DASH	1
27	C34794	SCREW, 1/4-20X .50 WAHTAP	2
28	C34834	SCREW, 1/4-20X .63 HHWATAP	4
29	C35083	NUT, 1/4-20 WDFLLK TOPLOCK	4
30	C35084	DASH,PLAIN SUS W/CHOKE	1
31	C34834	SCREW, 1/4-20X .63 HHWATAP	2
32	C35083	NUT, 1/4-20 WDFLLK TOPLOCK	2
33	C35085	HOOD, H-18 TWIN ENGINES	1
34	C35086	FOAM HOOD Baffle	1
35	C35087	PANEL,SIDE,HOOD,LH H-10,-18	1
36	C35088	PANEL,SIDE,HOOD RH H-10,-18	1
37	C35089	SCREW, 10-16X .50 WAHTAP	8
38	C35090	CLIP, U-TYPE, TINNEMAN	1
39	C35091	SPRING, HOOD SINGLE CYL	1
40	C35092	BRACKET,ACCESS COVER	1
41	C35093	SCREW, 10-24X.50 WAHMA	1
42	C35094	NUT, #10-24 HEXNYLLK	1
43	C35095	ASSY,GRILLE G-13 LOWES	1
44	C35096	GRILLE,	1
45	C35097	LENS,	1
46	C35098	DECAL, REFLECTOR,GRILL,G-13	1
47	C35380	SCREW, #6 X .50 PLASTITE	3
48	C35100	SCREW, 1/4-10X .75PHPNTAPGR2	8
49	C35101	BOLT, .375X .500 HHS 5/16-18	2
50	C34798	NUT, 5/16-18 REGHEXCTRLK	2
51	C35102	BRACKET GRILLE 2 HOL	1
52	C35100	SCREW, 1/4-10X .75PHPNTAPGR2	3
53	C35103	LANYARD,HOOD 11.75LG H15 VANG.	1
54	C35104	PIN, CLEVIS .672LGX.248DIA	1
55	C35105	WASHER, FLAT .281X .75X.090	1
56	C35106	PIN, HAIR .072 DIA X 1.13LG	1
57	C35107	SPRING, HOOD LATCH	1

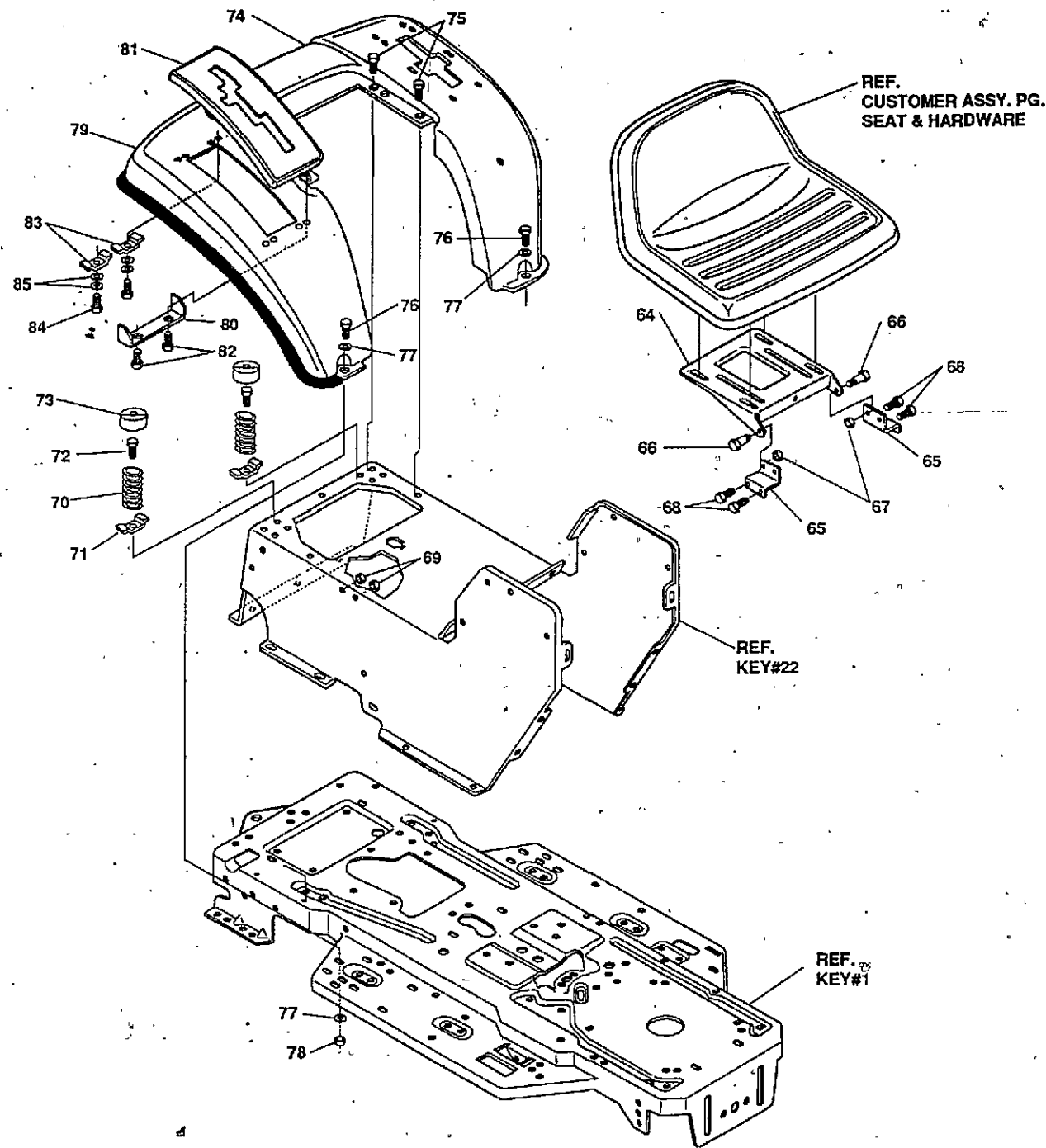

**CHASSIS AND HOOD ASSEMBLY**

key#	part#	description	qty.
64	C35110	PLATE, SEAT F-5 SF & LF	1
65	C35111	BRACKET, F-5 SEAT SUPPORT	1
66	C34816	BOLT, .437X .156 HSSH 5/16-18	2
67	C34798	NUT, 5/16-18 REGHEXCTRLK	2
68	C34796	SCREW, 5/16-18X .63 HHC GR2	4
69	C34798	NUT, 5/16-18 REGHEXCTRLK	4
70	C35112	SPRING, SEAT 2.63LG, 1.49OD	2
71	C35113	CLAMP, SPRING 1.17"ID	2
72	C34808	SCREW, 1/4-20X .75 HXWATAP	2
73	C35114	COVER, SEAT SPRING 1.51DX1.0LG	2
74	C35115	FENDER F-5 LF SOF, SUSP.	1
75	C34794	SCREW, 1/4-20X .50 WAHTAP	4
76	C34802	SCREW, 5/16-18X1.00 HHC GR2	2
77	C35116	WASHER, FLAT .375X .88X.082	4
78	C34798	NUT, 5/16-18 REGHEXCTRLK	2
79	C35117	TRIM, STRIP, BLACK-	77.5"
80	C35118	BRACKET, COVER F-5 SOF	1
81	C35119	COVER, PLASTIC LF HYDRO F-5	1
82	C35120	SCREW, 1/4-15X.44/.53 HILOHWA	2
83	C35113	CLAMP, SPRING 1.17"ID	2
84	C35120	SCREW, 1/4-15X.44/.53 HILOHWA	2
85	C35122	WASHER, FLAT .281X .63X.065	2

MOWER SUSPENSION ASSEMBLY

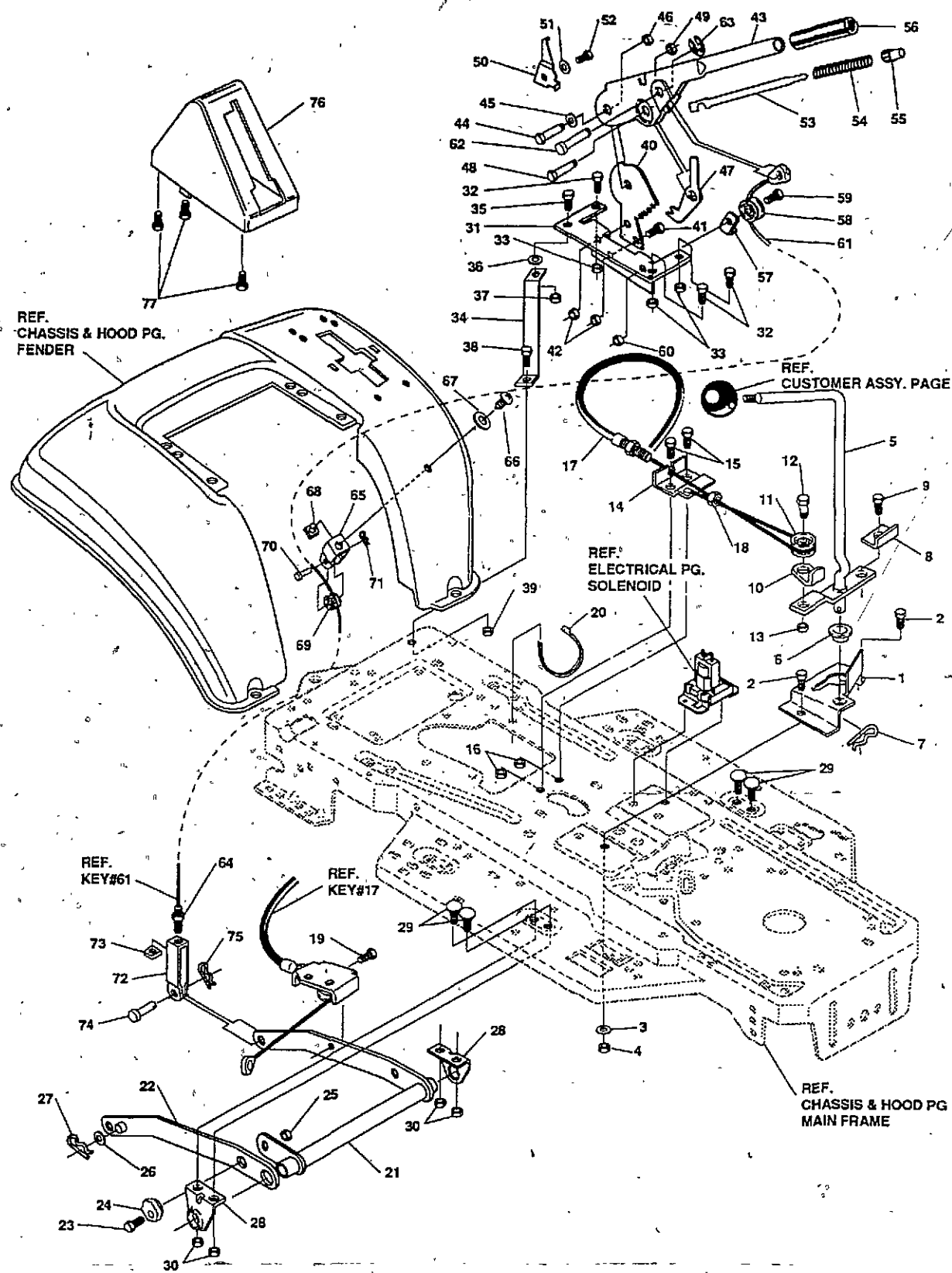

key#	part#	description	qty.
1	C35123	BRACKET,CLUT-ENGAGELEVER	1
2	C35124	SCREW, 5/16-18X1.00 HHC	2
3	C34878	WASHER, FLAT .344X.68X.065	2
4	C34798	NUT, 5/16-18 REGHEXCTRLK	2
5	C35125	ASSY,CLUTCH LEVER	1
6	C35128	BEARING,FL .503IDX.628OD	1
7	C34908	PIN, HAIR .091 DIA X1.66LG	1
8	C35127	BRACKET,SWITCH ENGAGE	1
9	C34800	SCREW, 5/16-18X.75 WAHHTAP	1
10	C35128	BRKT,CABLE RETAINER	1
11	C35129	PULLEY .906X.305 NYLON	1
12	C35130	BOLT, .375X.375 HSH 1/4-20	1
13	C34806	NUT, 1/4-20 REGHEXCTRLK	1
14	C35131	BRKT, FRAME CABLE	1
15	C35132	SCREW, 1/4-20X.75 HHC	2
16	C34806	NUT, 1/4-20 REGHEXCTRLK	2
17	C35133	ASSY,CABLE, BLADE ENGAGE	1
18	C35134	NUT, 1/4-28 HJAM	1
19	C34800	SCREW, 5/16-18X.75 WAHHTAP	1
20	C35334	TIE, CABLE BLACK NYLON	1
21	C35138	ASSY,REAR LIFT	1
22	C35137	ASSY,LINK,RIGHT SIDE	1
23	C35124	SCREW, 5/16-18X1.00 HHC	1
24	C35139	ADJUSTING NUT	1
25	C34798	NUT, 5/16-18 REGHEXCTRLK	1
26	C34892	WASHER, FLAT .531X1.06X.095	2
27	C34908	PIN, HAIR .091 DIA X1.66LG	2
28	C35140	BRKT,REAR,HANG,SUSP.	2
29	C34857	BOLT, 5/16-18X.63 CARR	4
30	C34798	NUT, 5/16-18 REGHEXCTRLK	4
31	C35141	BRACKET,HGT/ADJUST SUPPORT	1
32	C35006	SCREW, 5/16-18X.75 HHC	3
33	C34798	NUT, 5/16-18 REGHEXCTRLK	3
34	C35142	BRACE, FENDER F-5 SUS	1
35	C35124	SCREW, 5/16-18X1.00 HHC	1
36	C34899	WASHER, FLAT .333X.87X.119	1
37	C34798	NUT, 5/16-18 REGHEXCTRLK	1
38	C35124	SCREW, 5/16-18X1.00 HHC	1
39	C34798	NUT, 5/16-18 REGHEXCTRLK	1
40	C35143	QUADRANT,HEIGHT ADJUST	1
41	C35006	SCREW, 5/16-18X.75 HHC	2
42	C34798	NUT, 5/16-18 REGHEXCTRLK	2
43	C35144	HANDLE,LIFT SHORT BLK	1
44	C35145	BOLT, .500X.270 HSH 5/16-18	1
45	C35146	WASHER, FLAT .506X.75X.024	1
46	C34960	NUT, 5/16-18 HWDFLCTRLK	1
47	C35147	PAWL, HEIGHT ADJUST	1
48	C35145	BOLT, .500X.270 HSH 5/16-18	1
49	C34960	NUT, 5/16-18 HWDFLCTRLK	1
50	C35148	POINTER Z-PL	1
51	C35149	WASHER, EXLK, 195X.41X.03	1
52	C34988	SCREW, #8-32X.38 HWAT	1
53	C35150	ROD,ACTUATOR-SHORT	1
54	C35151	SPRING, HEIGHT ADJUST	1
55	C35152	KNOB, HGT ADJ PUSH BUTTON	1
56	C35153	GRIP, .750 OD W/ HOLE	1
57	C35154	BRKT, CABLE RETAIN	1
58	C35129	PULLEY .906X.305 NYLON	1
59	C35130	BOLT, .375X.375 HSH 1/4-20	1
60	C34806	NUT, 1/4-20 REGHEXCTRLK	1
61	C35155	CABLE, LIFT 21.70 F-5 20X8-8	1
62	C35156	PIN,CLEVIS .310DIA+.475LG	1
63	C35157	RING, RET E .31X.24	1
64	C35158	NUT, 1/4-20 REGHEX	1
65	C35159	CLEVIS	1
66	C35160	SCREW, 5/16-18X.56PHPNMA BKPH	1
67	C35161	WASHER, .344IDX1.50DX.09 CU BPH	1
68	C35162	NUT, 5/16-18 SQ	1
69	C35129	PULLEY .906X.305 NYLON	1
70	C35163	PIN, CLEVIS .38 DIA X1.00 LG	1
71	C34908	PIN, HAIR .091 DIA X1.66LG	1
72	C34825	CLEVIS, LIFT CABLE	1
73	C34824	NUT, 1/4-20 REGSO	1
74	C34826	PIN CLEVIS .312 X .812	1
75	C35164	PIN, COTTER .090/.086X.75LG	1
76	C35165	LIFT COVER-39" F5	1
77	C35166	SCREW, #10 X.75 HHPLAST	3

**FRONT WHEEL STEERING ASSEMBLY**

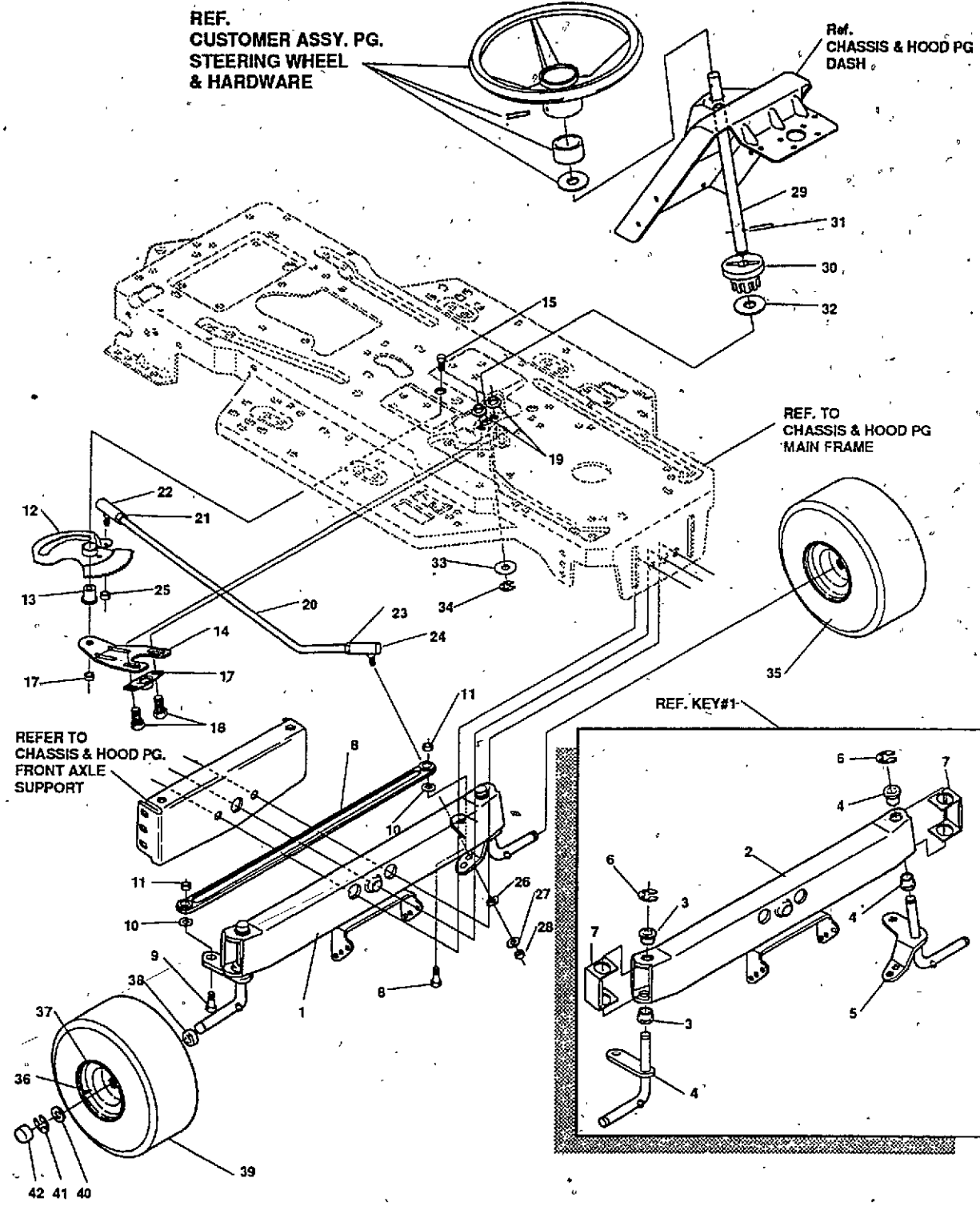

key#	part#	description	qty.
1	*	AXLE, FRONT ASSY SUS 4WS LF	1
2	C35167	ASSY, FRONT AXLE SUS	1
3	C35168	SPINDLE BEARING	4
4	C35169	ASSY, SPINDLE RH LONG	1
5	C35170	ASSY, SPINDLE, LH LONG	1
6	C34917	RING, RETEX .57X.05TRU5133-75	2
7	C35171	AXLE COVER	2
8	C35172	TIE ROD ASSY 19.81LG W-SECTION	1
9	C35173	SCREW, 3/8-16X1.75 HHC	2
10	C34861	WASHER, REGSPTLK.393X.68X.10	2
11	C35174	NUT, 3/8-16 REGHEX	2
12	C35175	ASSY SECTOR GEAR 4WS LF	1
13	C35176	BUSHING, SECTOR GEAR 4WS LF*	1
14	C35177	SUPPORT, SECTOR GEAR 4WS LF*	1
15	C35178	SCREW, 1/2-20X3.00 HHC	1
16	C35219	NUT, 1/2-20 REGHXCTRLK	1
17	C35180	BEARING FLANGE 0.5 BORE	1
18	C35071	SCREW, 5/16-18X.75WDFLLK	2
19	C35072	NUT, 5/16-18 HXWDFLLK	2
20	C35181	DRAG LINK .625 DIA LF 4WS	1
21	C35182	NUT, 3/8-24 REGHEXJAM	1
22	C35183	BALL JOINT 3/8 THD SHORT STUD	1
23	C35184	NUT, 7/16-20 HXJAM	1
24	C35185	JOINT, BALL ASSY 7/16-20	1
25	C35186	NUT, 3/8-24 WDFLHLK WHIZ	1
26	C34892	WASHER, FLAT .531X1.06X.095	1
27	C34881	WASHER, REGSPTLK.459X.78X.12	1
28	C35187	NUT, 7/16-20 REGHX	1
29	C35188	SHAFT, STEERING 4WS LF	1
30	C35189	PINION STEERING	1
31	C35190	PIN DOWEL STR ERO LT	1
32	C35191	WASHER, FLAT 1.38 X .51X.043	1
33	C35192	WASHER, FLAT .504X.75X.059	1
34	C34979	RING, RET E .39X.04TRU5133-50	1
35	*	TIRE & RIM, PU 15X6.0X6 TURF	2
36	G34920	VALVE STEM	1
37	C35193	WHEEL W/BRG.	1
38	C35194	BEARING	1
39	**	TIRE	1
40	C35195	WASHER, FLAT .755X1.31X.075	4
41	C34917	RING, RETEX .57X.05TRU5133-75	2
42	C34918	CAP, HUB	2

\* Order Individual Parts  
 \*\*Order Tires at Local Tire Dealer

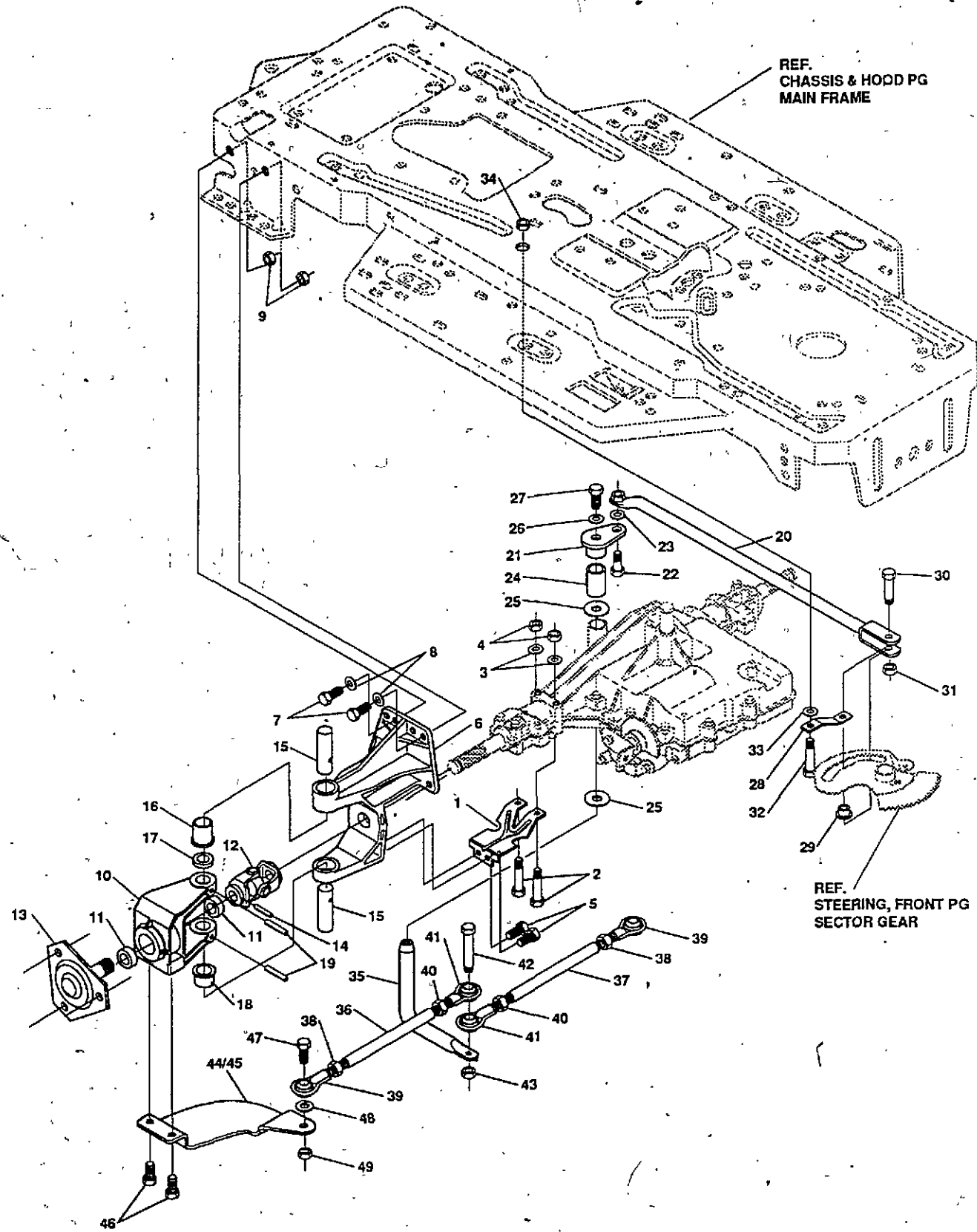

**REAR WHEEL STEERING ASSEMBLY**

key#	part#	description	qty.
1	C35196	BRKT X-AXLE MTG	2
2	C35234	SCREW, 5/16-18X2.25 HHC	4
3	C34876	WASHER, FLAT .344X.69X.065	4
4	C34798	NUT, 5/16-18 REGHEXCTRLK	4
5	C35198	SCREW, 5/16-18X.63HWATAP	4
6	C35199	BRCKT,STRG PIVOT W/DRILL HOLES	2
7	C34802	SCREW, 5/16-18X1.00 HHC	8
8	C34876	WASHER, FLAT .344X.69X.065	8
9	C34798	NUT, 5/16-18 REGHEXCTRLK	8
10	C35200	BRACKET,STR PIVOT	2
11	C35201	BEARING	4
12	C35202	U-JOINT ASSEMBLY	2
13	C35203	HUB ASSEMBLY GREY 861	2
14	C35204	PIN, GROOVED .250 DIA X1.50LG	2
15	C35205	PIN; STEERING HINGE	4
16	C35206	BUSHING, SHOULDERED (OILITE	2
17	C35207	WASHER, FLAT .765X1.25X.042 PL	2
18	C35208	BUSHING, SHOULDERED (OILITE	2
19	C35209	PIN, SPRING.250DIA X1.50LG HVPL	4
20	C35210	ROD ASM., DRAGLINK	1
21	C35211	PIVOT, STEERING	1
22	C35212	BOLT, .562X.340 HMSH 3/8-24	1
23	C34889	WASHER, FLAT .406X.81X.065	1
24	C35213	SPACER, STEERING SHAFT	1
25	C35214	WASHER, FLAT .765X1.19X.048	2
26	C34899	WASHER, FLAT .333X.87X.119	1
27	C35215	SCREW, 5/16-24X1.00 HHC	1
28	C35216	ARM ROLLER SWING 4 W	1
29	C35217	CAM YOKE ROLLER	1
30	C35218	SHOULDER BOLT CAM ROLLER	1
31	C35219	NUT, 1/2-20 REGHXCTRLK	1
32	C35220	SHOUL BOLT CAM FOLLOWER	1
33	C34889	WASHER, FLAT .406X.81X.065	1
34	C35221	NUT, 3/8-24 HXCTRLK	1
35	C35222	SHAFT, STEERING PIVOT	1
36	C35223	ROD, TIE 1/2"D X 8.00LG	1
37	C35224	ROD, TIE 1/2"D X 9.5LG	1
38	C35225	NUT, 3/8-24 LH THD REGHJAM	2
39	C35226	ROD,TIE END LH 3/8-24 EURO	2
40	C35182	NUT, 3/8-24 REGHEXJAM	2
41	C35227	ROD, TIE END RH	2
42	C35641	SCREW, 3/8-24X1.75 HHC	1
43	C35221	NUT, 3/8-24 HXCTRLK	1
44	C35229	ARM RW STR ERO RH	1
45	C35230	ARM RW STR ERO LH	1
46	C35231	SCREW, 3/8-16X.75WAHHTAP BK	4
47	C35232	SCREW, 3/8-24X1.25 HHC	2
48	C34861	WASHER, REGSPTLK.393X.68X.10	2
49	C35221	NUT, 3/8-24 HXCTRLK	2

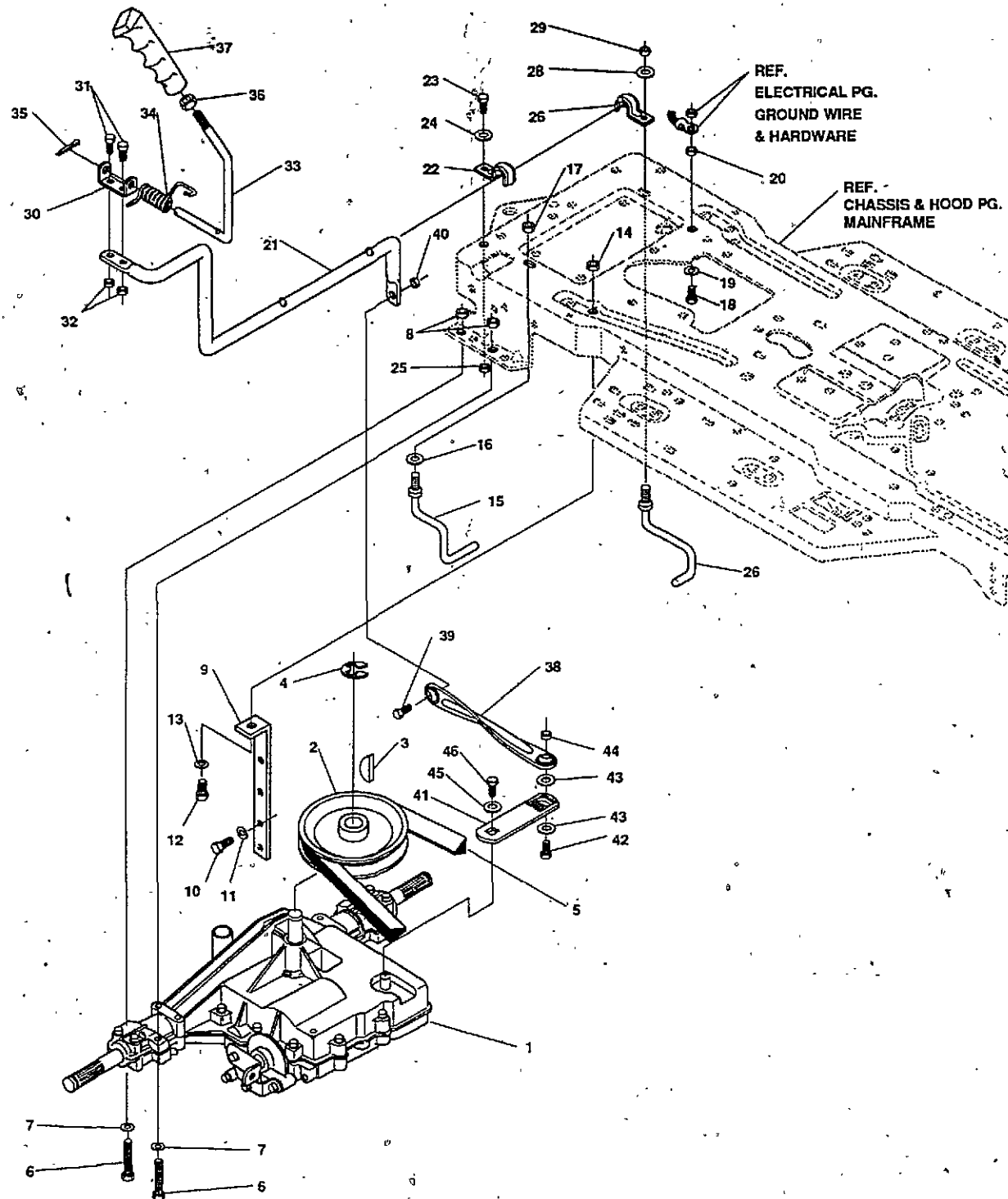

**MOTION DRIVE ASSEMBLY**

key#	part#	description	qty.
1	C34516*	TRANSAXLE ASSEMBLY	1
2	C34873	PULLEY, V4L 920TA	1
3	C34909	KEY, WDRF 606 .750X.187X.312	1
4	C34874	RING, RETEX .58X.04TRU5100-62	1
5	C35233	BELT, V 4L 87.25 4WS LF	1
6	C35234	SCREW, 5/16-18X2.25 HHC GR5	4
7	C34876	WASHER, FLAT .344X.69X.065	4
8	C34798	NUT, 5/16-18 REGHEXCTRLK	4
9	C35235	BRACKET, STABILIZER	1
10	C34800	SCREW, 5/16-18X.75 WAHTAP	2
11	C35054	WASHER, HVSP TLK .328X.60X.09	2
12	C34802	SCREW, 5/16-18X1.00 HHC GR2	1
13	C34876	WASHER, FLAT .344X.69X.065	1
14	C34798	NUT, 5/16-18 REGHEXCTRLK	1
15	C35236	GUIDE, BELT 5/16-18THD	1
16	C35054	WASHER, HVSP TLK .328X.60X.09	1
17	C34798	NUT, 5/16-18 REGHEXCTRLK	1
18	C34796	SCREW, 5/16-18X.63 HHC GR2	1
19	C35237	WASHER, REGINTLK.320X.61X.03	1
20	C34798	NUT, 5/16-18 REGHEXCTRLK	1
21	C35238	LEVER, SHIFT, LWR 4360 LF	1
22	C35239	CLIP-SHIFT LEVER .62 ROD	1
23	C35006	SCREW, 5/16-18X.75 HHC GR5	1
24	C35240	WASHER, FLAT .391X1.00X.125	1
25	C34798	NUT, 5/16-18 REGHEXCTRLK	1
26	C35239	CLIP-SHIFT LEVER .62 ROD	1
27	C35241	GUIDE, BELT 5/16-18THD	1
28	C35240	WASHER, FLAT .391X1.00X.125	1
29	C34798	NUT, 5/16-18 REGHEXCTRLK	1
30	C35242	BRACKET, PIVOT SHIFT LEVER	1
31	C35243	SCREW, 1/4-20X.62 HHC GR5	2
32	C34806	NUT, 1/4-20 REGHEXCTRLK	2
33	C35244	LEVER, SHIFT UPPER SF 1/2-13TH	1
34	C35426	SPRING, TORS. .56X.95X.095	1
35	C34890	PIN, COTTER .125 DIA X1.00LG	1
36	C35246	NUT, 1/2-13 HEXJAM	1
37	C35247	HANDLE 1/2-13 MOLDED	1
38	C35248	LINK TIEROD SHIFT P930-6 SHORT	1
39	C35249	SCREW, 3/8-16X1.25 HHC GR5	1
40	C34814	NUT, 3/8-16 REGHXCTRLK	1
41	C35250	BRACKET, SHIFT 5SP SF FEN HT	1
42	C35249	SCREW, 3/8-16X1.25 HHC GR5	1
43	C34889	WASHER, FLAT .406X.81X.065	2
44	C34814	NUT, 3/8-16 REGHXCTRLK	1
45	C34886	WASHER, .750X.250 SP-TRANSAXLE	1
46	C34887	SCREW, 1/4-28X.75 NYLHHCGR8	1

\*See Transaxle Section



**MOTION DRIVE ASSEMBLY**

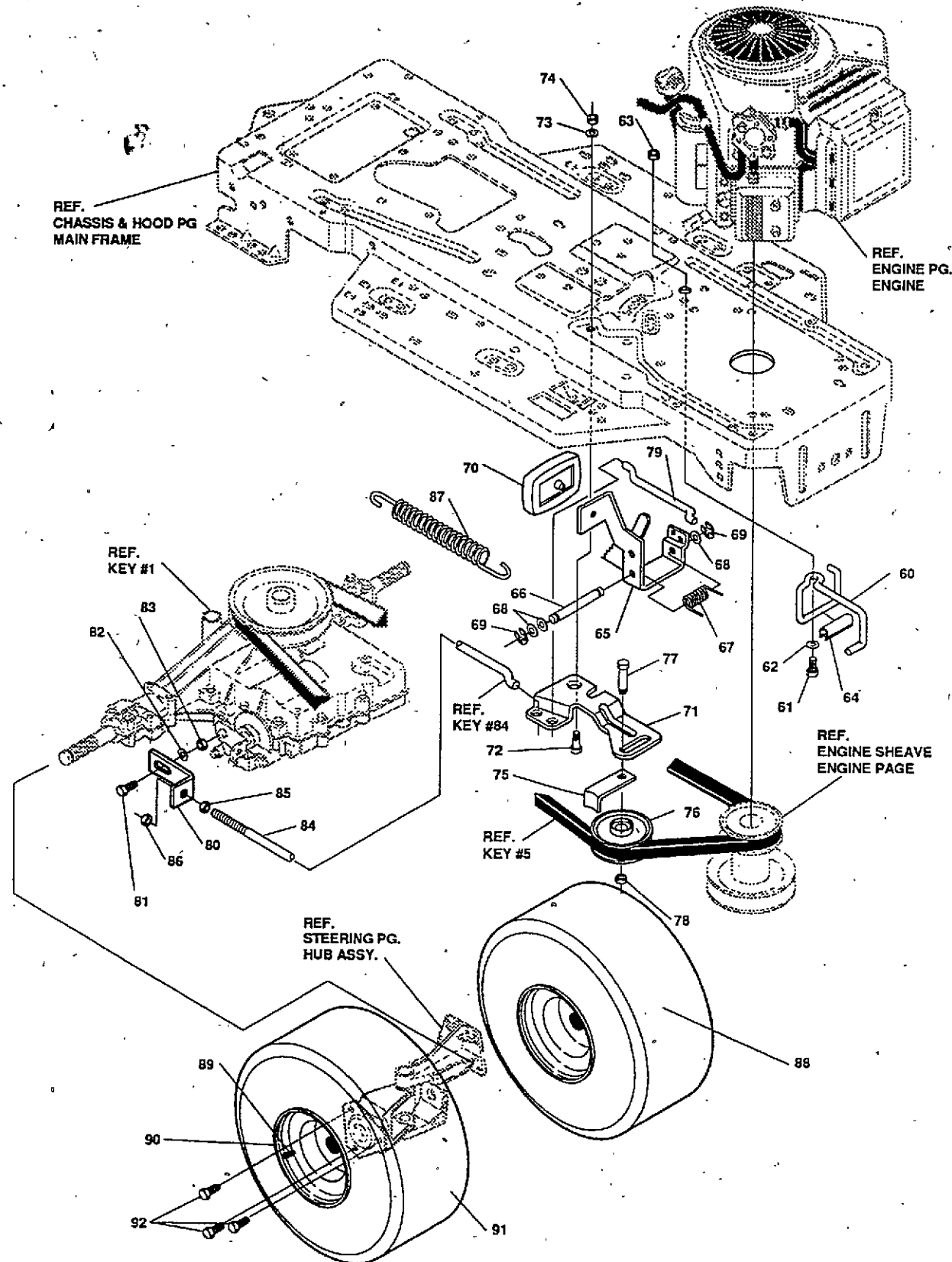

key#	part#	description	qty.
60	C35251	GUIDE-BELT/DRAGLINK LF 4WS	1
61	C35124	SCREW, 5/16-18X1.00 HHC GR5	1
62	C34899	WASHER, FLAT .333X .87X.119	1
63	C34798	NUT, 5/16-18 REGHEXCTRLK	1
64	C35253	PLASTIC EXTRUSION-BELT GUIDE	1
65	C35254	PEDAL ASSY, BRAKE/CLUTCH LF	1
66	C34980	ROD, PIVOT .50 OD+4.44LG	1
67	C35255	SPRING, BRAKE PEDAL	1
68	C35192	WASHER, FLAT .504X .75X.059	3
69	C34979	RING, RET E .39X.04TRU5133-50	2
70	C35256	PAD, CLUTCH BRAKE W/PRINTING	1
71	C35257	ARM, IDLER TRACTION DR. LF	1
72	C35258	BOLT, .625X .135 HSSH 5/16-18	1
73	C34899	WASHER, FLAT .333X .87X.119	1
74	C34798	NUT, 5/16-18 REGHEXCTRLK	1
75	C34903	RETAINER, BELT	1
76	C34902	PULLEY, IDLER V4L 3.06X .62	1
77	C34905	BOLT, 3/8-16X1.50 CARR GR2	1
78	C34814	NUT, 3/8-16 REGHXCTRLK	1
79	C35259	ROD, CLUTCH	1
80	C34993	BRACKET, BRAKE ROD	1
81	C34816	BOLT, .437X .156 HSSH 5/16-18	1
82	C34899	WASHER, FLAT .333X .87X.119	1
83	C34798	NUT, 5/16-18 REGHEXCTRLK	1
84	C35260	ROD, BRAKE P920 4WS LF 23.50	1
85	C34833	NUT, 5/16-18 HEXKEPS	1
86	C34798	NUT, 5/16-18 REGHEXCTRLK	1
87	C35261	SPRING, CLUTCH .113X.750X8.75	1
88	*	TIRE & RIM, PU 20-10X8 SIL880	2
89	C34920	VALVE STEM	1
90	C35262	RIM, WHEEL	1
91	**	TIRE	1
92	C35263	SCREW, 1/2-20X .50 HHC GR2	6

\* Order Individual Parts

\*\*Order Tires at Local Tire Dealer

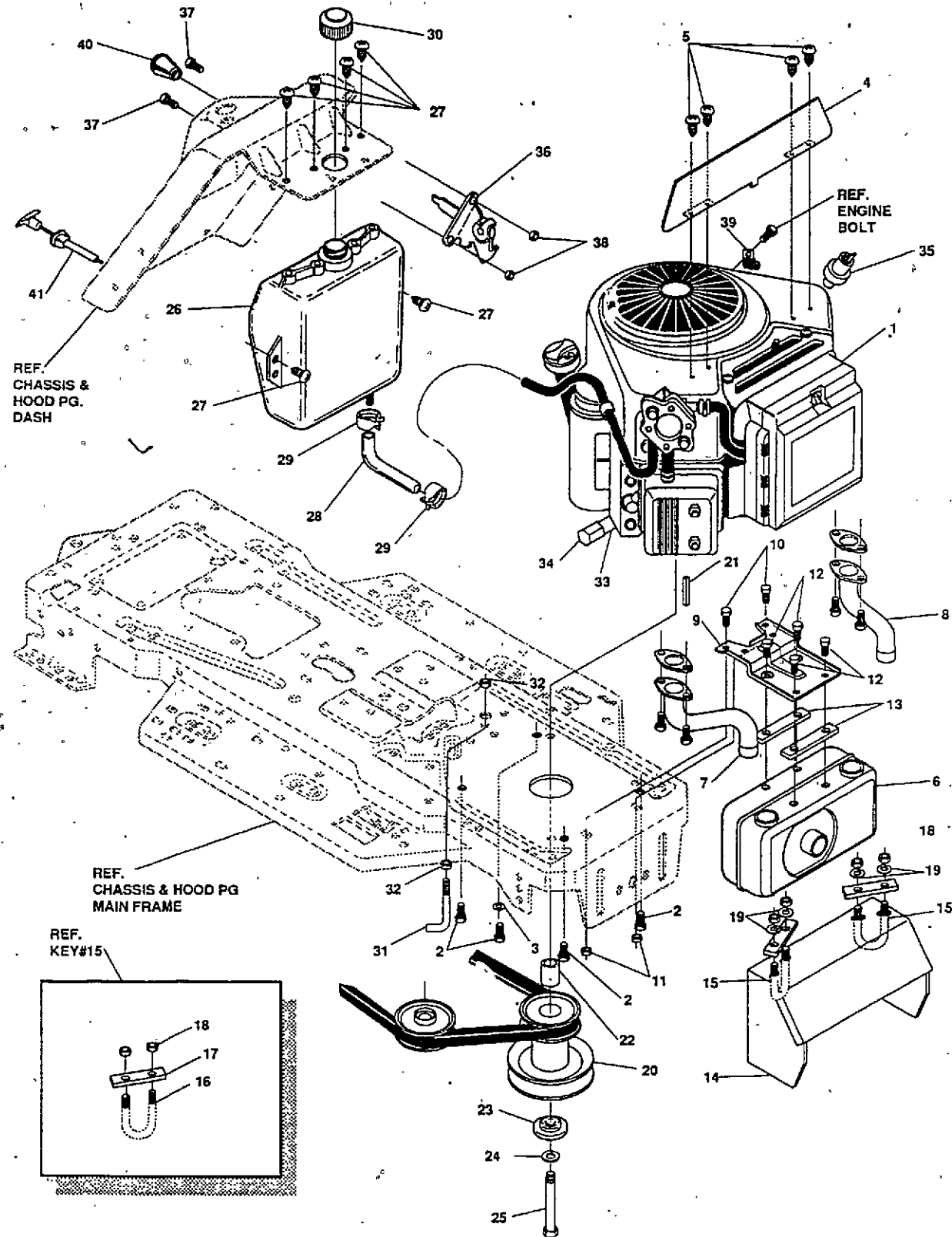

**ENGINE AND CONTROL ASSEMBLY**

key#	part#	description	qty.
1	C34537*	ENGINE - 14 HP	1
2	C35264	SCREW, 3/8-16X1.25 WAHTAP	4
3	C35265	WASHER, EXLK.384X.69X.04	1
4	C35266	HEAT SHIELD VAN ENG	1
5	C34971	SCREW, 10-16X .50 DRILLTITE	4
6	C35267	MUFFLER 15HP B&S VANG.H10/G13	1
7	C35268	EXHAUST TUBE ASM. RH	1
8	C35269	EXHAUST TUBE ASM. LH	1
9	C35270	BRACKET, MUFFLER	1
10	C35071	SCREW, 5/16-18X.75WDFLLK GR5	2
11	C35072	NUT, 5/16-18 HXWDFLLK	2
12	C34808	SCREW, 1/4-20X .75 HXWATAP	4
13	C35271	PLATE, GUIDE	2
14	C35272	HEAT SHIELD, MUFFLER	1
15	C35273	U-BOLT & PLATE ASSY	2
16	C35274	U-BOLT 1/4-20 X 1.0 X 1.75	1
17	C35275	PLATE, U-BOLT	1
18	C35158	NUT, 1/4-20 REGHEX	2
19	C35568	WASHER, REGSPTLK.263X.49X.07	4
20	C35277	PULLEY, ENG 4.40OFF/5.00D/3.00D	1
21	C35278	KEY, SQUARE .250SQX5.00LG	1
22	C35279	SPACER, 1.01X1.484 ENGIN PULLEY	1
23	C34925	WASHER, .980IDX1.38ODX.437PILOT	1
24	C34881	WASHER, REGSPTLK.459X.78X.12	1
25	C35280	SCREW, 7/16-20X5.00 HHC	1
26	C35281	TANK, FUEL 2GAL CLEAR	1
27	C35100	SCREW, 1/4-10X .75PHPNTAPGR2	6
28	C34965	GAS LINE .25ID BULK LENGTH	10'
29	C34966	CLAMP, FUEL LINE	2
30	C35282	GAS CAP 1-1/2-7 THD	1
31	C35283	ROD, UPSTOP	1
32	C35284	NUT, 3/8-16, HWDFL WHIZ-LOCK ZN	2
33	C35285	NIPPLE 3/8-18 NPT X 4"	1
34	C35286	CAP, PIPE 3/8-18 NPT	1
35	C35287	OIL SENSOR, B&S TWIN CYL.	1
36	C35288	CONTROL, THROTTLE 33.5LG BS VAN	1
37	C35289	SCREW, 10-24X .63PHPNMA GR2BK	2
38	C35290	NUT, #10-24 HEXKEPS	2
39	C35011	RETAINER, .311DX.62X.03 WIRE	1
40	C35291	KNOB, ROUND THROTTLE	1
41	C35292	CONTROL, CHOKE 35.25LG	1

\*See Engine Section

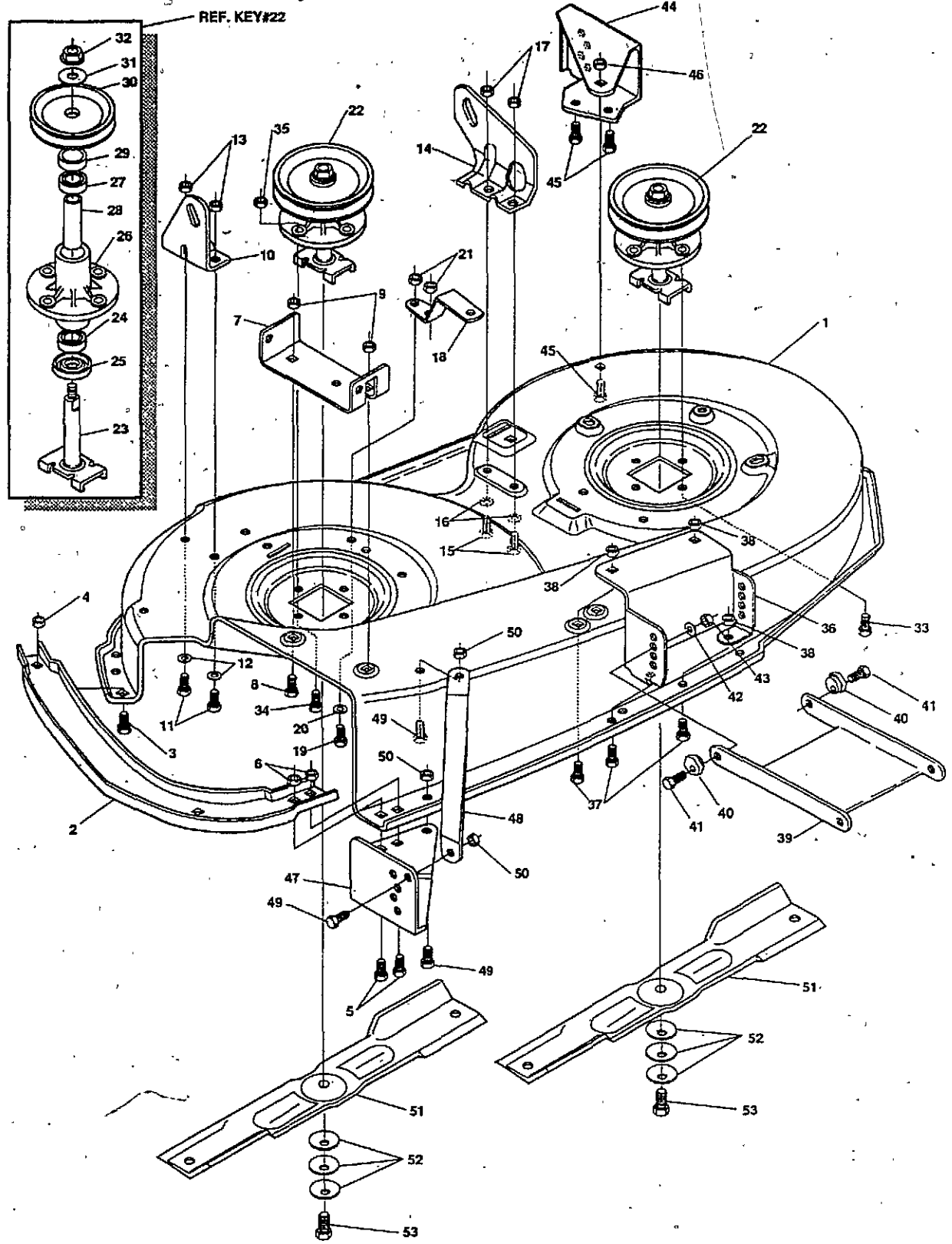

**PRE-PAINTED DECK ASSEMBLY**

key#	part#	description	qty.
1	C35293	MOWER DECKS, RIDER 43"	1
2	C35294	TOE GUARD	1
3	C35295	SCREW, 5/16-18X .63 HHC.	1
4	C34798	NUT, 5/16-18 REGHEXCTRLK	1
5	C34856	SCREW, 5/16-18X .75 HHC	2
6	C34798	NUT, 5/16-18 REGHEXCTRLK	2
7	C35296	BRACKET CHUTE MOUNT	1
8	C35295	SCREW, 5/16-18X .63 HHC	2
9	C34798	NUT, 5/16-18 REGHEXCTRLK	2
10	C35297	LIFT BRACKET, REAR,RH	1
11	C35006	SCREW, 5/16-18X .75 HHC	2
12	C34876	WASHER, FLAT .344X .69X.065	2
13	C34798	NUT, 5/16-18 REGHEXCTRLK	2
14	C35298	BRACKET,DECK LIFTREAR LH	1
15	C35006	SCREW, 5/16-18X .75 HHC	2
16	C34876	WASHER, FLAT .344X .69X.065	2
17	C34798	NUT, 5/16-18 REGHEXCTRLK	2
18	C35299	BRACE IDLER	1
19	C35006	SCREW, 5/16-18X .75 HHC	2
20	C34876	WASHER, FLAT .344X .69X.065	2
21	C34960	NUT, 5/16-18 HWDFLCTRLK	2
22	C35300	QUILL ASSY, 36/39/40/43	2
23	C35301	SHAFT/SADDLE 36"	1
24	C34983	BRNG, BALL	1
25	C34985	DUST SHIELD	1
26	C35302	QUILL CASTING (1046)	1
27	C34983	BRNG, BALL	1
28	C35303	SPACER,3.797LGX.669IDX.88OD	1
29	C35304	SPACER, .438LGX.932ODX.672ID	1
30	C34989	PULLEY,26/36" QUILL	1
31	C34990	SPECIAL WASHER	1
32	C34991	NUT, 7/16-20 WDFLLK	1
33	C34992	SCREW, 5/16-18X .88 WAHHTAP	7
34	C35307	SCREW, 5/16-18X1.38 WATAPGR	1
35	C34798	NUT, 5/16-18 REGHEXCTRLK	1
36	C35308	BRACKET FRT.	1
37	C35295	SCREW, 5/16-18X .63 HHC	4
38	C34798	NUT, 5/16-18 REGHEXCTRLK	4
39	C35309	LINK BRACKET,DECK FR	1
40	C35139	ADJUSTING NUT	2
41	C34802	SCREW, 5/16-18X1.00 HHC	2
42	C35311	WASHER, FLAT .328X1.06X.062	2
43	C34798	NUT, 5/16-18 REGHEXCTRLK	2
44	C35312	BRACKET,GAGE WHEEL L.H	1
45	C35295	SCREW, 5/16-18X .63 HHC	3
46	C34798	NUT, 5/16-18 REGHEXCTRLK	3
47	C34313	BRACKET,GAGE WHEEL R.H.	1
48	C35314	BRACKET,STABILIZER	1
49	C35295	SCREW, 5/16-18X .63 HHC	3
50	C34798	NUT, 5/16-18 REGHEXCTRLK	3
51	C35315	BLADE, 21.70 HIGH-LIFT	2
52	C34997	WASHER, .39IDX1.25DX.07 BELLVIL	6
53	C34998	SCREW, 3/8-24X1.00 NYLHHC	2

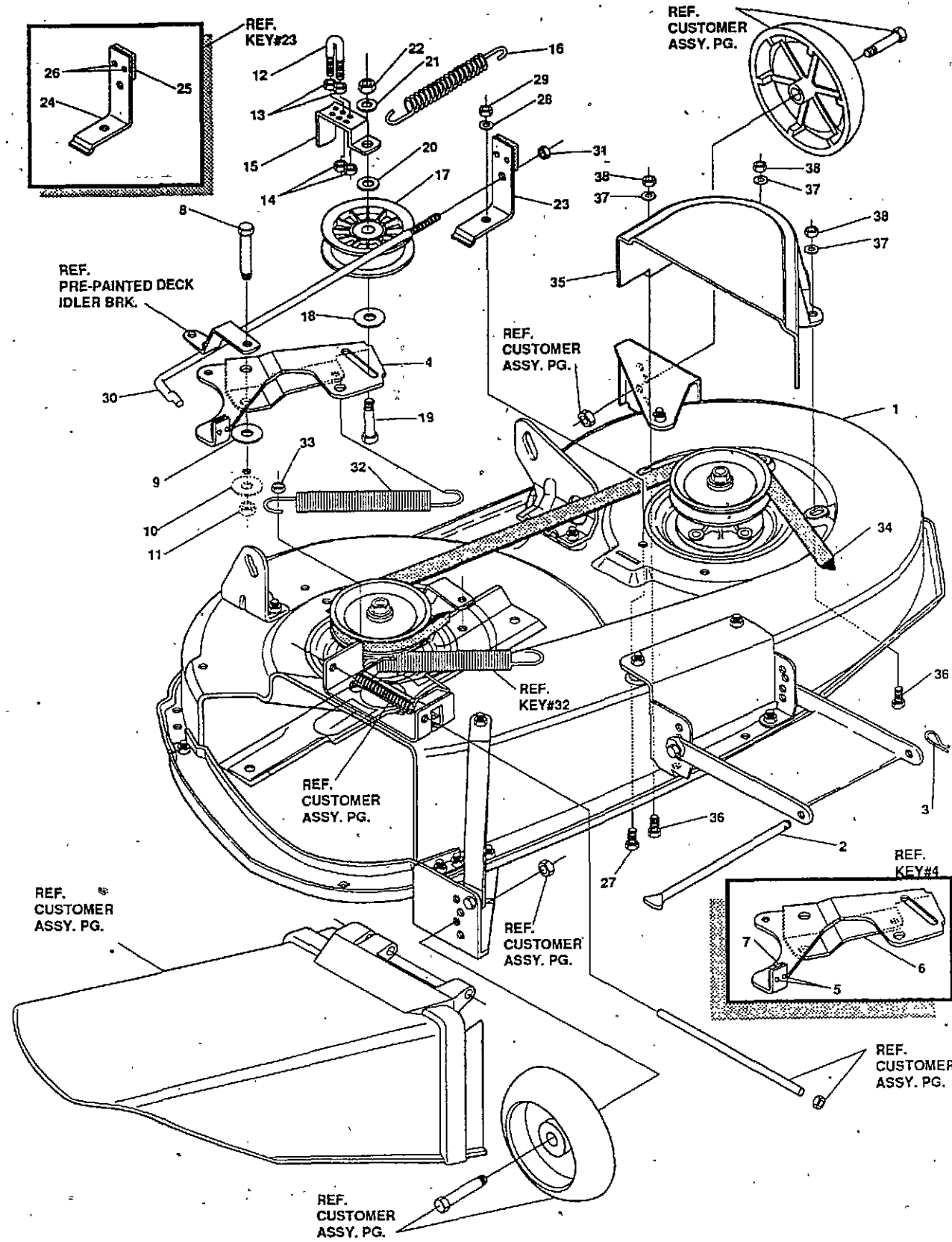

**FINAL DECK ASSEMBLY**

key#	part#	description	qty.
1		DECK, 43" MOWER ASSEMBLY	1
2	C35316	ROD, DECK HITCH Z-PL	1
3	C34908	PIN, HAIR .091 DIA X 1.66 LG	1
4	C35317	ASSY, IDLER ARM	1
5	C34953	RIVET, OVSET .187 DIA X .50 LG	2
6	NSS	ARM IDLER (NOT SERVICE PART, ORDER KEY 4)	1
7	C34951	BRAKE PAD - HARD - 232AF	1
8	C35318	BOLT, .500 X 2.15 HX HDCPSH	1
9	C35319	WASHER, FLAT .391 X 1.00 X .209	1
10	C35240	WASHER, FLAT .391 X 1.00 X .125	1
11	C35284	NUT, 3/8-16 HWD FL WHIZ NUT	1
12	C35320	U-BOLT	1
13	C35290	NUT, #10-24	2
14	C35322	NUT, #10-24 REGHXCTRLK	2
15	C35323	GUIDE, BELT, IDLER ZINC	1
16	C35324	SPRING, TENSION 5.00 LG	1
17	C35458	PULLEY, IDLER BFF 4.00 WIDE FL	1
18	C35326	WASHER, FLAT .392 X 1.25 X .09	1
19	C35327	BOLT, 3/8-16 X 2.00 CARR	1
20	C35319	WASHER, FLAT 391 X 1.00 X .125	1
21	C34861	WASHER, REGSPTLK.393 X .68 X .10	1
22	C35174	NUT, 3/8-16 REGHX	1
23	C35328	BLADE BRAKE ASSY.	1
24	NSS	BRAKE ARM (NOT SERVICE PART, ORDER KEY 23)	1
25	C34951	BRAKE PAD	1
26	C34950	RIVET	2
27	C34796	SCREW, 5/16-18 X .63 HHC	1
28	C34876	WASHER, FLAT .344 X .69 X .065	1
29	C34798	NUT, 5/16-18 REGHEXCTRLK	1
30	C35329	ROD, BRAKE	1
31	C34806	NUT, 1/4-20 REGHEXCTRLK	1
32	C34901	SPRING .071 X .62 X 4.37	1
33	C34798	NUT, 5/16-18 REGHEXCTRLK	1
34	C35330	BELT, V 5L 86.00 KEVLAR	1
35	C35331	GUARD, BELT LH PLASTIC	1
36	C34796	SCREW, 5/16-18 X .63 HHC	3
37	C34876	WASHER, FLAT .344 X .69 X .065	3
38	C34798	NUT, 5/16-18 REGHEXCTRLK	3

\*Order Individual Parts

**ELECTRICAL ASSEMBLY**

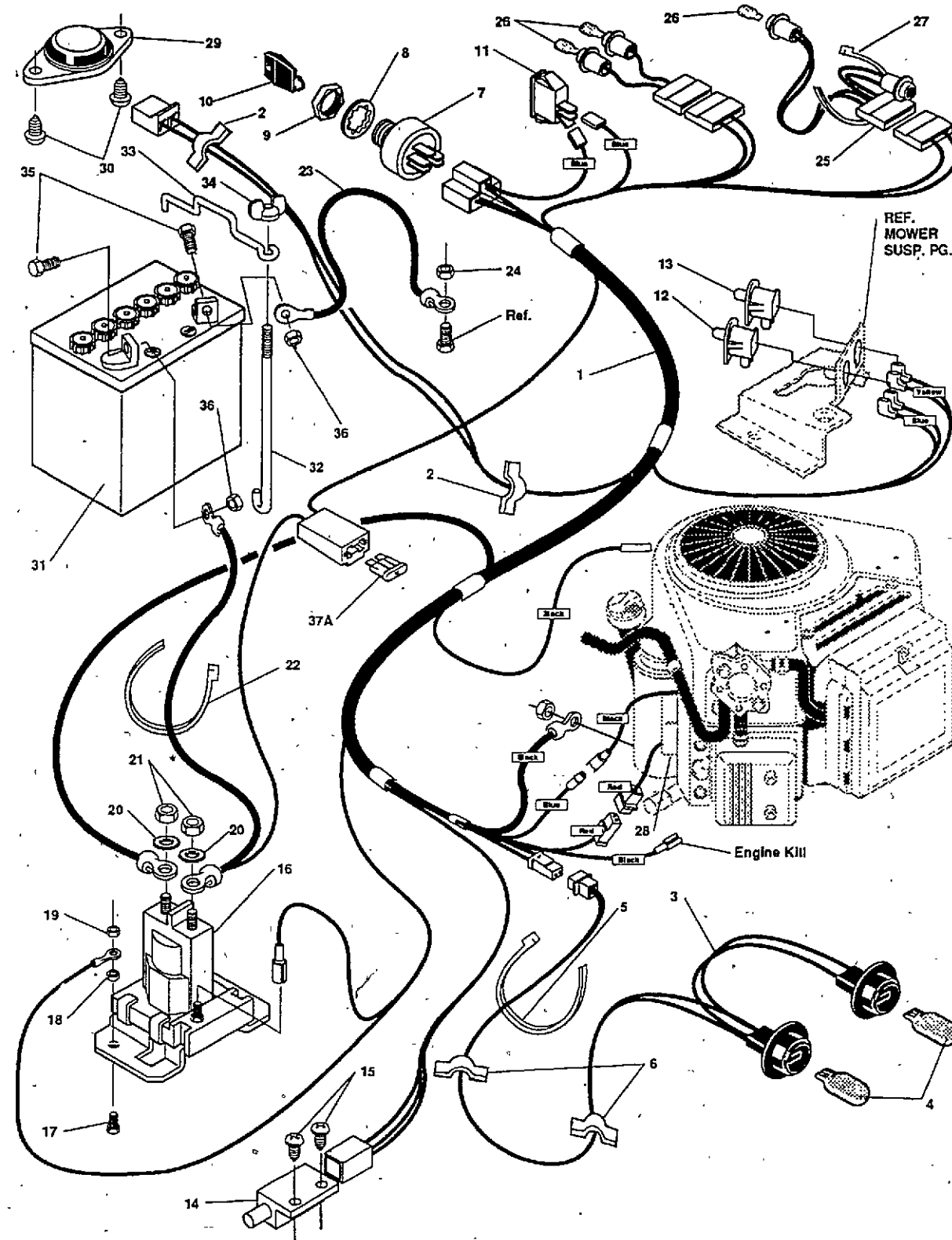

key#	part#	description	qty.
1	C35332	WIRE HARNESS 14-18B&SVANG	1
2	C35030	PRESS CLIP, 1.380LG .255ID	2
3	C35333	ASSY, LIGHT WIRE-1/4 TURN	1
4	C35035	BULB, HEADLAMP	2
5	C35334	TIE, CABLE BLACK NYLON 5.62L	1
6	C35030	PRESS CLIP, 1.380LG .255ID	2
7	C35335	SWITCH-IGN.(AFTER FIRE) 3 POSN	1
8	C35336	WASHER, REGINTLK.640X1.1X.05	1
9	C35337	NUT, 5/8-32 HXHD IGN SWIT	1
10	C35021	KEY, IGNITION SWITCH	1
11	C35338	LIGHT SWITCH ON/OFF PANEL MNT	1
12	C35339	SWITCH, SNAPMNT NO .055/.116	1
13	C35017	SWITCH, SNAPMNT NC .055/.166	1
14	C35340	SWITCH, SCR MNT SP NO	1
15	C35016	SCREW, #12 X .50 PHPNHTAP	2
16	C35022	SOLENOID	1
17	C35023	SCREW, 1/4-20X .75 HXSEMMA	2
18	C34808	NUT, 1/4-20 REGHEXCTRLK	2
19	C35024	NUT, 1/4-20 REGHEXKEPS	1
20	C34922	WASHER, EXLK .320X.61X.03	2
21	C35640	NUT, 5/16-24 REGHEX	2
22	C35334	TIE, CABLE BLACK NYLON 5.62	1
23	C35033	WIRE, GROUND, 12.5"	1
24	C34833	NUT, 5/16-18 HEXKEPS	1
25	C35342	HARNESS LIGHT 2 I.L.	2
26	C35343	BULB, INDICATOR	3
27	C35334	TIE, CABLE BLACK NYLON 5.62	1
28	C35344	REGULATOR, SEN VOLT BS W/SENSOR	1
29	C35345	SWITCH, SEAT	1
30	C35346	SCREW, 1/4-20X .38PHPNHMAGR2	2
31	C35347	BATTERY U1-9L 12VOLT 28 AMP HR	1
32	C35348	ROD, BATTERY	1
33	C35349	ROD, BATTERY, TOP	1
34	C35032	NUT, WING 1/4-20 SMALL PLASTIC	1
35	C35350	SCREW, 1/4-20X .63 HHC GR2	2
36	C35024	NUT, 1/4-20 REGHEXKEPS	2
37A	C35036**	Fuse, 15 amp Spade Type	1
37B	C35351**	Fuse, 15 amp Cylindrical Type	1

\*\*Cylindrical or Spade type fuses are included with the wire harness.

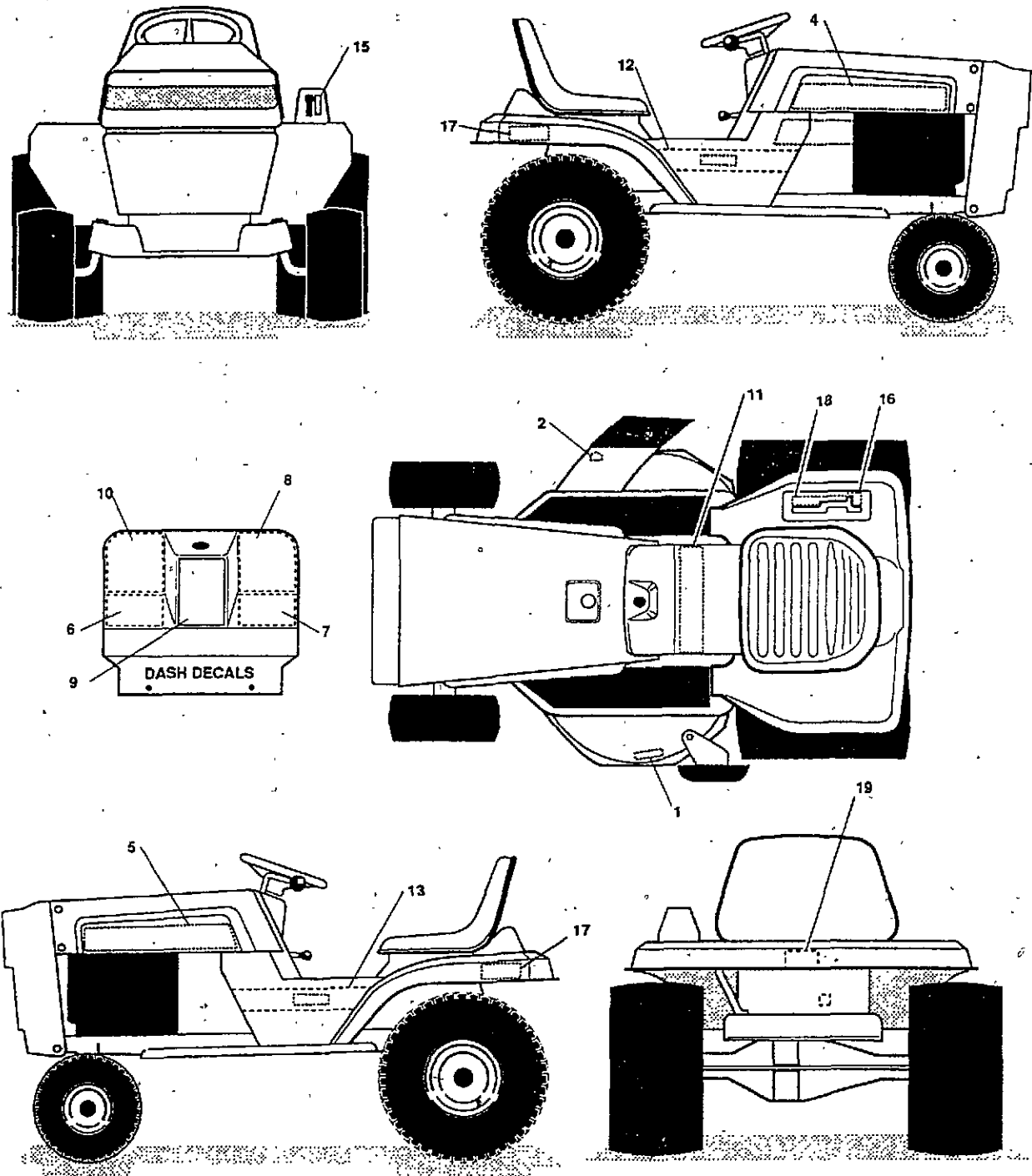

DECALS

key#	part#	description	qty.
1	C35050	DECAL, NO STEP	2
2	C35049	DECAL, CUT-HAND WARNING LABEL	1
3		REFERENCE ONLY	1
4	C35352	DECAL, HOOD SIDE RH 1114AWS	1
5	C35353	DECAL, HOOD SIDE LH 1114AWS	1
6	C35354	DECAL, DASH, LH, BLANK, H10/G13	1
7	C35355	DECAL, DASH, RH ISO	1
8	C35356	DECAL, DASH, RH IGN. W/O LIGHTS	1
9	C35357	DECAL, CENTER, ENGLISH INSTRUCT.	1
10	C35358	DECAL, DASH, LH, THROTTLE H10/G13	1
11	C35359	DECAL CAUTION CONSOLE TOP LF	1
12	C35360	DECAL, CONSOLE RH	1
13	C35361	DECAL, CONSOLE LH	1
14		REFERENCE ONLY	1
15	C35362	DECAL, LIFT-DECK BLADE HEIGHT	1
16	C35363	DECAL SHIFT REV/NEUTRAL	1
17	C35364	DECAL, ALL WHEEL STEER	2
18	C35365	DECAL SHIFTER POSITION	1
19	C35052	NAMEPLATE, INGERSOIL	1

## CUSTOMER ASSEMBLY

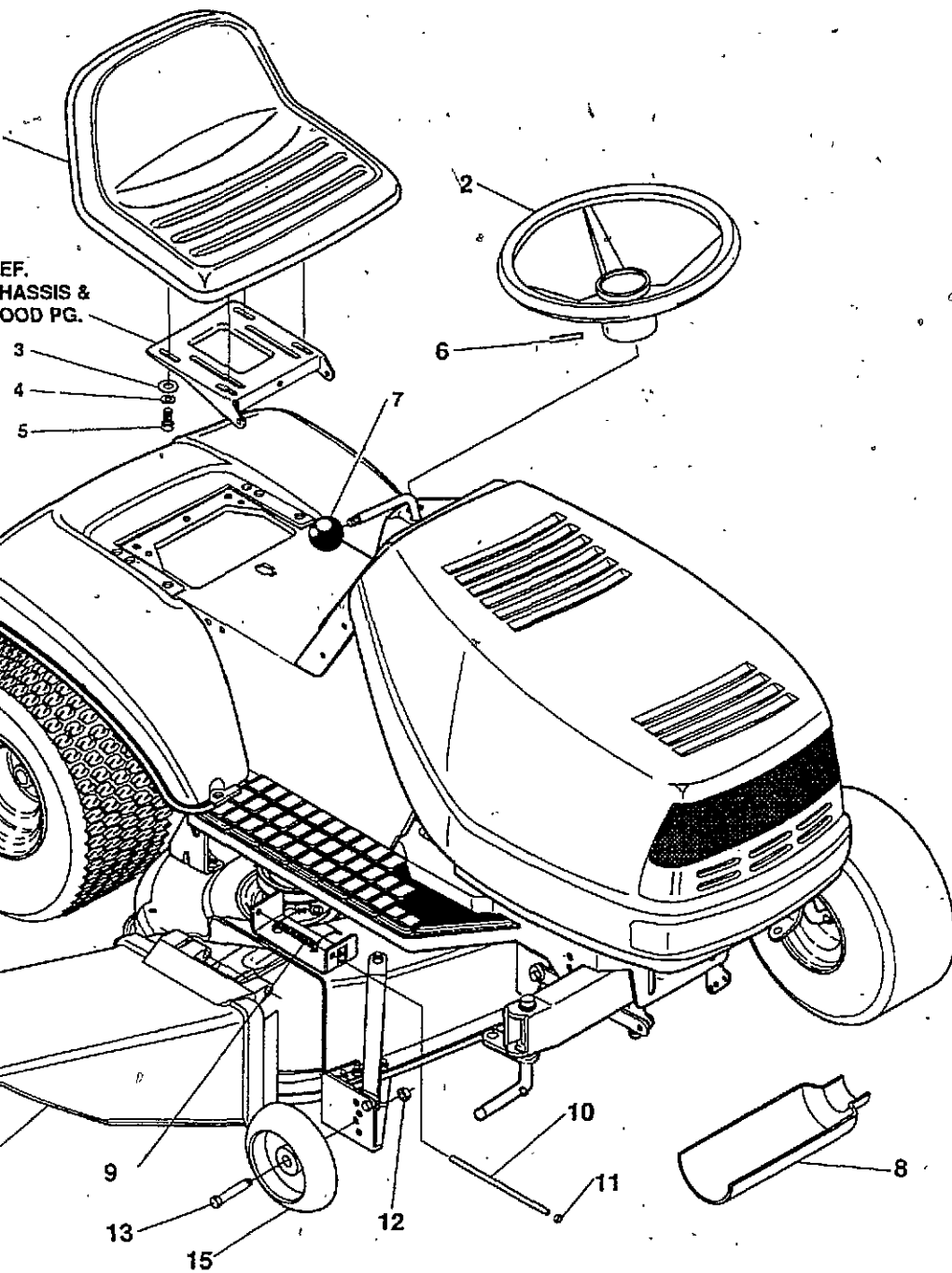

key#	part#	description	qty
1	C35366	SEAT MV450	1
2	C35367	STEERING WHEEL 14" EURO	1
3	C34876	WASHER, FLAT .344X.69X.065	4
4	C35054	WASHER, HVSPTLK .328X.60X.09	4
5	C34856	SCREW, 5/16-18X.75 HHC	4
6	C35368	PIN, SPRING .250DIA X 2.00LG	1
7	C35053	KNOB	1
8	C35389	OIL TROUGH	1
9	C34839	TORSION SPRING	1
10	C35370	ROD, PIVOT	1
11	C35371	PUSH NUT	1
12	C34814	NUT, 3/8-16 REGHXCTRLK	2
13	C34828	BOLT, .500X1.390 HSSH 3/8-16	2
14	C35372	CHUTE DEFLECTOR	1
15	C35373	DECK WHEEL	2

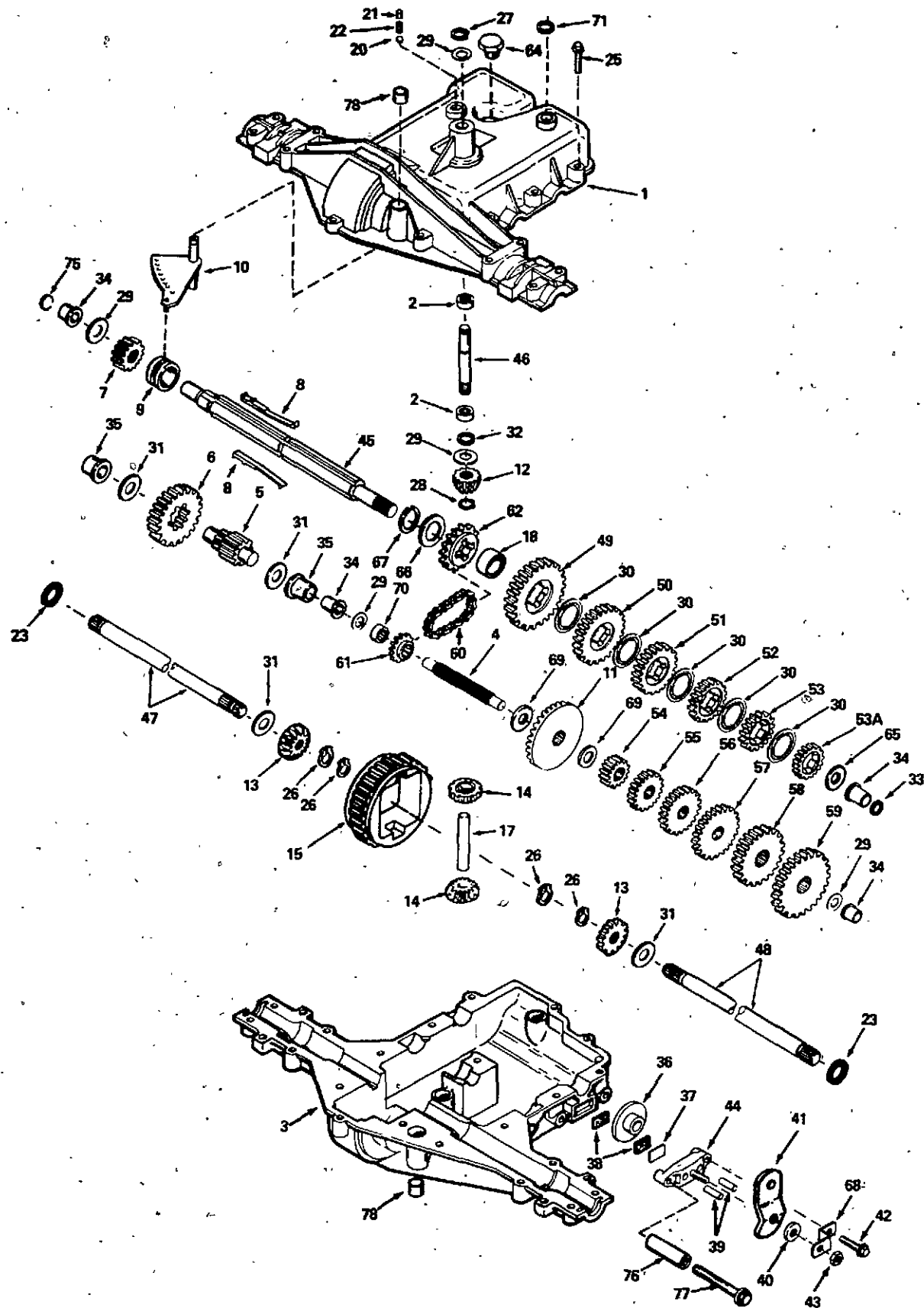

**C34516 TRANSAXLE ASSEMBLY**

KEY	PART NO.	DESCRIPTION	
1	C34486	COVER - TRANSAXLE	1
2	C28649	BEARING - NEEDLE	2
3	C34487	CASE - TRANSAXLE	1
4	C34488	SHAFT - COUNTER	1
5	C34489	SHAFT & PINION ASSY - OUTPUT	1
6	C27562	GEAR - OUTPUT	1
7	C27553	GEAR - SPUR 15T	1
8	C34490	KEY	1
9	C34491	COLLAR - SHIFTER	4
10	C34492	ROD & FORK ASSY - SHIFT	1
11	C34493	GEAR - BEVEL 42T	1
12	C28652	GEAR - BEVEL PINION, INPUT	1
13	C30500	GEAR - BEVEL	2
14	C19310	GEAR - BEVEL PINION	2
15	C34494	GEAR - RING	1
17	C34495	PIN - DRIVE	1
18	C34496	SPACER	1
20	C28667	BALL - STEEL 5/16" DIA.	1
21	C34148	SCREW - SET 3/8"-16 X 3/8"	1
22	C28654	SPRING	1
23	C34497	RING - SEAL	2
25	C34147	SCREW - 1/4"-20 X 1-1/4" FLANGE, TAPPING	17
26	C34156	RING - RETAINER (PKG. OF 2)	4
27	C19347	RING - RETAINER	1
28	C19352	RING - RETAINER	1
29	C19345	WASHER - THRUST	5
30	C28664	WASHER - THRUST	5
31	C11205	WASHER	4
32	C28648	"O" RING	1
33	C27570	SEAL - SQUARE CUT	1
34	C28653	BUSHING - FLANGED	4
35	C27565	BUSHING - FLANGED	2
36	C27563	DISK - BRAKE	1
37	C19354	PLATE - BRAKE PAD	1
38	C19353	PAD - BRAKE	2
39	C28650	PIN - DOWEL	2
40	C19357	WASHER - FLAT	1
41	C34498	LEVER - BRAKE	1
42	C34147	SCREW - 1/4"-20 X 1-1/4" FLANGE, SELF TAPPING	1
43	C19358	NUT - LOCK 5/16"-24	1
44	C34144	HOLDER - BRAKE PAD	1
45	C34499	SHAFT - BRAKE	1
46	C28651	SHAFT - INPUT	1
47	C34500	AXLE - 10" LONG	1
48	C34501	AXLE - 14-19/32" LONG	1
49	C34502	GEAR - SPUR 37T	1
50	C28658	GEAR - SPUR 30T	1
51	C34503	GEAR - SPUR 27T	1
52	C28657	GEAR - SPUR 25T	1
53	C27555	GEAR - SPUR 22T	1
53A	C28656	GEAR - SPUR 20T	1
54	C34504	GEAR - SPUR 12T	1
55	C28660	GEAR - SPUR 20T	1
56	C34505	GEAR - SPUR 32T	1
57	C28661	GEAR - SPUR 25T	1
58	C27556	GEAR - SPUR 28T	1
59	C28662	GEAR - SPUR 30T	1
60	C34506	CHAIN - ROLLER NO. 41, 22 LINKS	1
61	C34507	SPROCKET - 10T	1
62	C34508	SPROCKET - 14T	1
64	C27588	PLUG - HEX HD. 9/16-18	1
65	C28663	WASHER - THRUST	1
66	C34509	WASHER - THRUST	1
67	C34510	RING - RETAINING	1
68	C28821	BRACKET - BRAKE LEVER	1
69	C34511	WASHER - THRUST	2
70	C34512	SPACER	1
71	C34149	SEAL - SQUARE CUT	1
75	C34513	DISK	1
76	C34514	SPACER	1
77	C34515	SCREW - 1/4"-20 X 2-1/4" FLANGE, TAPPING	1
78	C19316	BEARING - BRONZE	2



**FLYWHEEL, CRANKSHAFT, CAMSHAFT AND PISTONS**

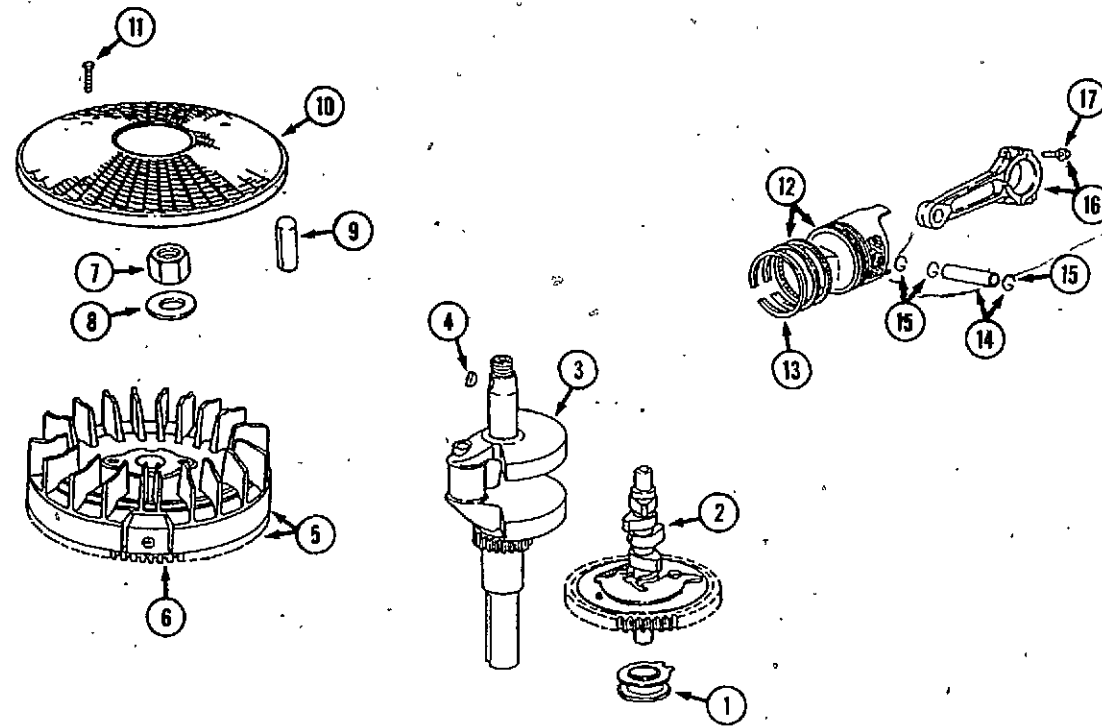

REF.	PART NO.	DESCRIPTION	REQ'D
1	C 34371	SLIDER - governor	1
2	C 34231	CAMSHAFT	1
3	C 34383	CRANKSHAFT	1
4	C 34211	KEY - flywheel	1
5	C 34210	FLYWHEEL - includes ring gear	1
6	C 34331	GEAR - ring	1
7	C 34288	NUT - flywheel	1
8	C 34237	WASHER - flywheel	1
9	C 34326	SPACER - screen	4
10	C 34287	SCREEN - flywheel	1
11	C 34238	SCREW - screen	4
12	C 34212	PISTON ASSEMBLY - standard (includes rings)	2
12	C 34213	PISTON ASSEMBLY - .010" oversize (includes rings)	2
12	C 34214	PISTON ASSEMBLY - .020" oversize (includes rings)	2
12	C 34215	PISTON ASSEMBLY - .030" oversize (includes rings)	2
13	C 34216	RING SET - piston, standard	1
13	C 34217	RING SET - piston .010" oversize	1
13	C 34218	RING SET - piston .020" oversize	1
13	C 34219	RING SET - piston .030" oversize	1
14	C 34221	PIN - piston, standard	2
15	C 34220	LOCK - piston pin	2
16	C 34222	ROD - connecting	2
17	C 34223	BOLT - connecting rod	2

**IGNITION AND CHARGING SYSTEMS**

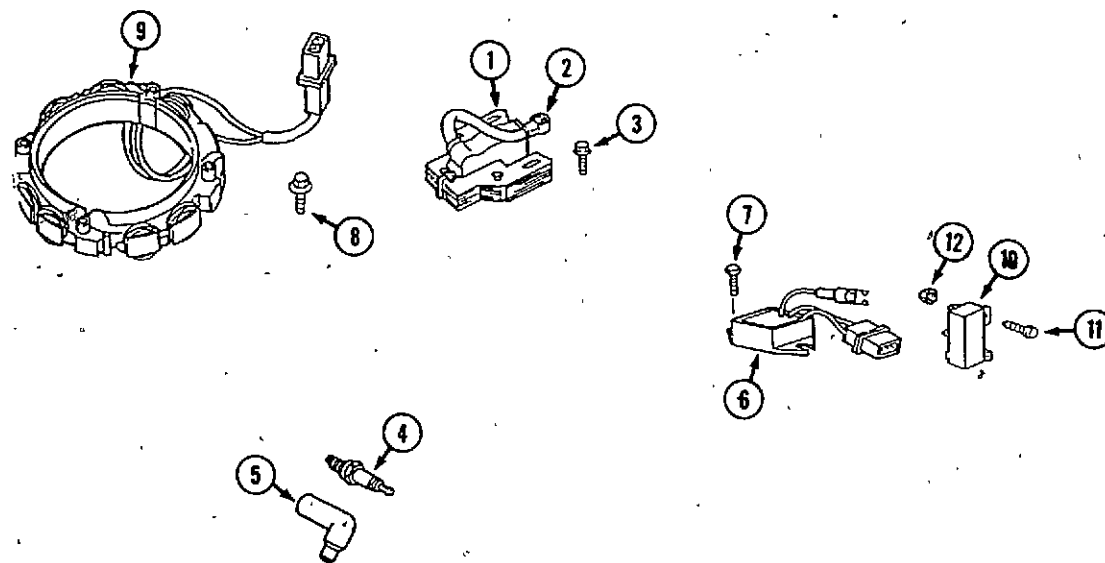

1	C 34289	ARMATURE - magnets	2
2	BR221798	TERMINAL - ignition cable	1
3	C 34290	SCREW - mounting	4
4	C 34291	SPARK PLUG	2
5	C 34324	BOOT - spark plug	2
6	C 35344	REGULATOR - alternator	1
7	C 34310	SCREW - mounting	2
8	C 34290	SCREW - mounting	4
9	C 34303	STATOR - alternator	1
10	C 34306	TERMINAL - ground	1
11	C 34292	BOLT - mounting	1
12	C 34293	NUT	1

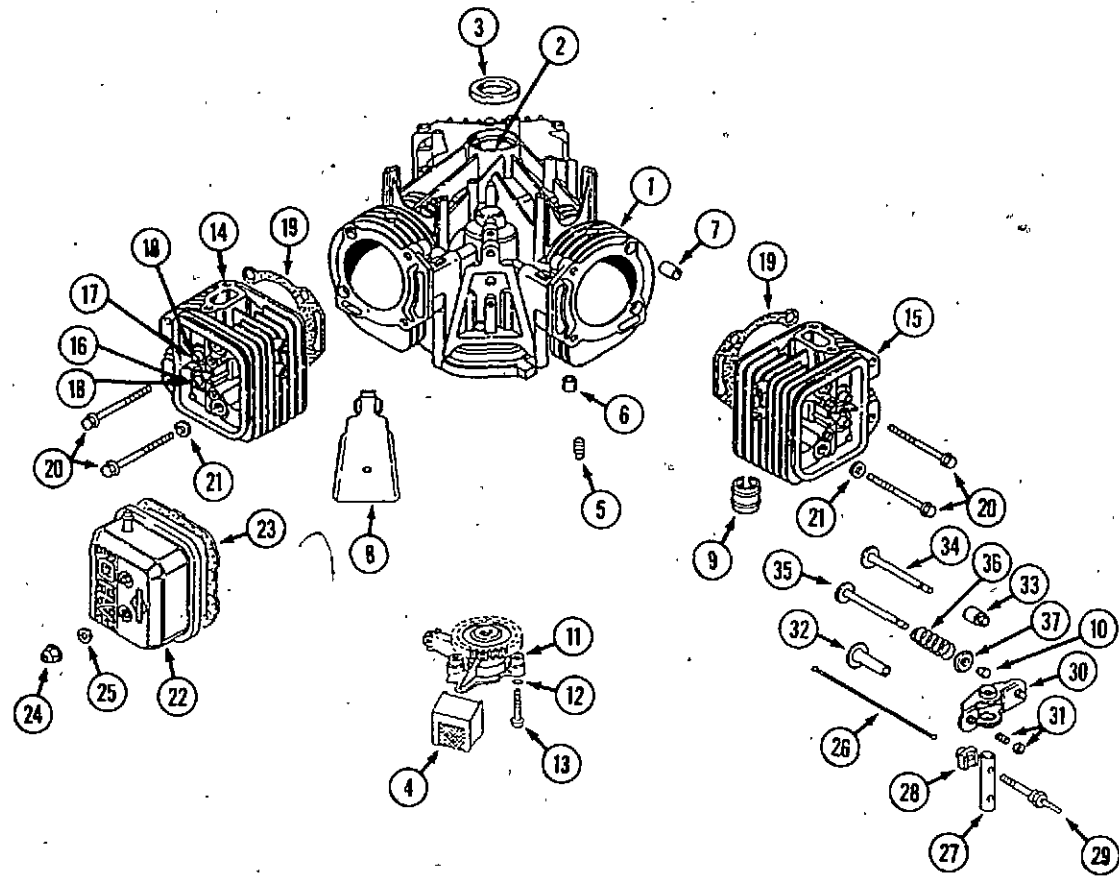

**ENGINE BLOCK AND CYLINDER HEADS**

REF.	PART NO.	DESCRIPTION	REQ'D
1	C 34380	BLOCK - cylinder (also includes Ref. 5, 6, 7)	1
2	C 34191	BEARING - main	1
3	C 34192	SEAL - oil	1
4	C 34398	SCREEN - oil pick-up	1
5	C 34239	PLUG - pipe	1
6	C 34327	DOWEL - crankcase	UAR
7	C 34328	DOWEL - cylinder head	UAR
8	C 34317	BAFFLE - breather	1
9	C 34342	LINER - exhaust port	2
10	C 34229	RETAINER - valve	4
11	C 34400	PUMP - oil	1
12	C 34246	"O" RING - pump	2
13	C 34338	SCREW - pump mounting	2
14	C 34193	HEAD - cylinder R.H., No. 1	1
15	C 34194	HEAD - cylinder L.H., No. 2	1
16	C 34348	SEAT - exhaust valve	2
17	C 34347	SEAT - intake valve	2
18	C 34349	GUIDE - valve	4
19	C 34196	GASKET - head	2
20	C 34202	BOLT - head	8
21	C 34195	WASHER - head bolt	8
22	C 34368	COVER - valve No. 2 L.H.	1
22	C 34369	COVER - valve No. 1 R.H.	2
23	C 34262	GASKET - valve cover	2
24	C 34262	NUT - lock, valve cover	4
25	C 34261	WASHER	4
26	C 34372	ROD - push, intake	2
26	C 34373	ROD - push, exhaust	2
27	C 34377	SHAFT - rocker arm	2
28	C 34378	SUPPORT - rocker arm	4
29	C 34259	STUD - rocker arm	4
30	C 34376	ARM - rocker	4
31	C 34265	SCREW AND NUT - valve adjust	4
32	C 34230	TAPPET - valve	4
33	C 34346	SEAL - valve guide	4
34	C 34224	VALVE - exhaust	2
35	C 34225	VALVE - intake	2
36	C 34226	SPRING - valve	4
37	C 34228	RETAINER - valve spring	4

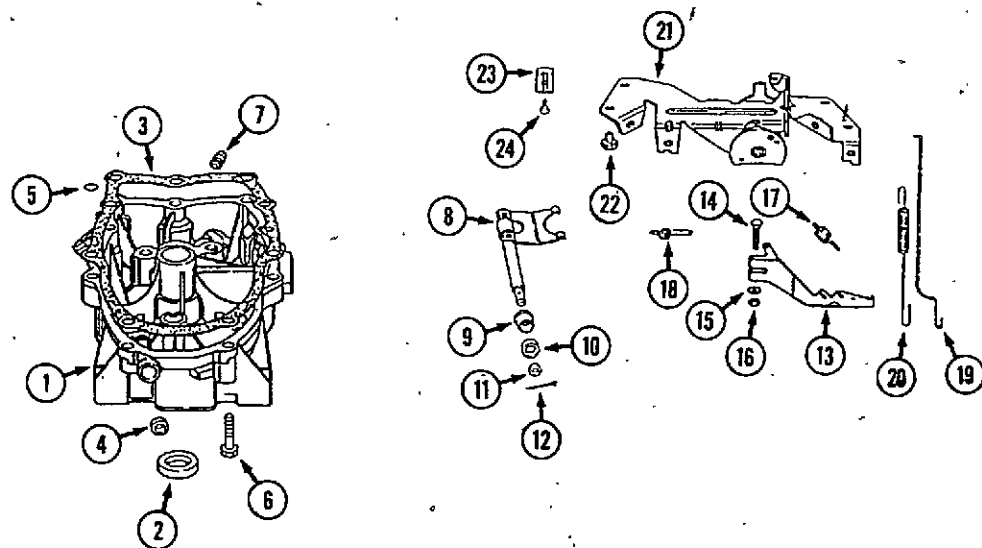
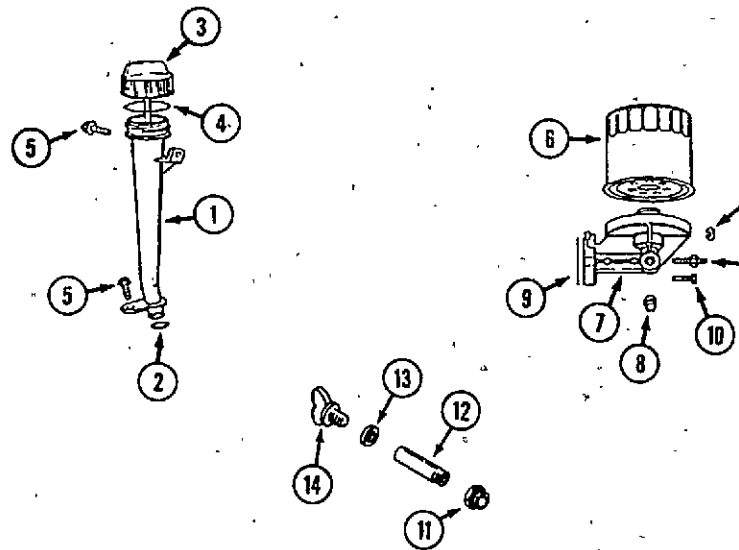

**OIL FILTER, FILLER TUBE AND DRAIN**

REF.	PART NO.	DESCRIPTION	REQ'D
1	C 34403	TUBE - oil filler	1
2	C 34402	SEAL - filler tube	1
3	C 34401	DIPSTICK	1
4	C 34406	"O" RING - filler tube	1
5	C 34339	SCREW	1
6	C 34374	FILTER - oil	1
7	C 34375	ADAPTER - oil filter	1
8	C 34239	PLUG - pipe	1
9	C 34361	GASKET - adapter	1
10	C 34362	SCREW - adapter	3
11	221- 86	REDUCER - pipe 3/8" to 1/4" oil drain	1
12	C 19473	NIPPLE - pipe, oil drain	1
13	C 14906	GASKET - oil drain	1
14	C 14399	PLUG -oil drain	1
15	C 34260	STUD - adapter	1
16	C 34264	LOCKWASHER	1

**CRANKCASE COVER AND GOVERNOR**

1	C 34384	COVER - crankcase	1
2	C 34208	SEAL - oil	1
3	C 34201	GASKET - crankcase cover	1
4	C 34323	WASHER - governor shaft	1
5	C 34247	"O" RING - crankcase cover	1
6	C 34209	BOLT - crankcase cover	8
7	C 34203	PLUG - pipe	1
8	C 34322	SHAFT - governor	1
9	C 34314	BUSHING - governor shaft	1
10	C 34315	BUSHING - governor shaft	1
11	C 34240	SEAL - governor shaft	1
12	C 34321	PIN - cotter	1
13	C 34270	LEVER ASSEMBLY - governor	1
14	C 34316	BOLT - lever	1
15	C 34275	WASHER - lever	1
16	C 34319	NUT - lever	1
17	C 34267	SPRING - governor	1
18	C 34397	SPRING - governed idle	1
19	C 34266	LINK - governor	1
20	C 34271	SPRING - governor link	1
21	C 34269	BRACKET - governor control	1
22	C 34281	SCREW - bracket	4
23	BR221535	CLAMP - casing	1
24	C 34292	SCREW - clamp	1

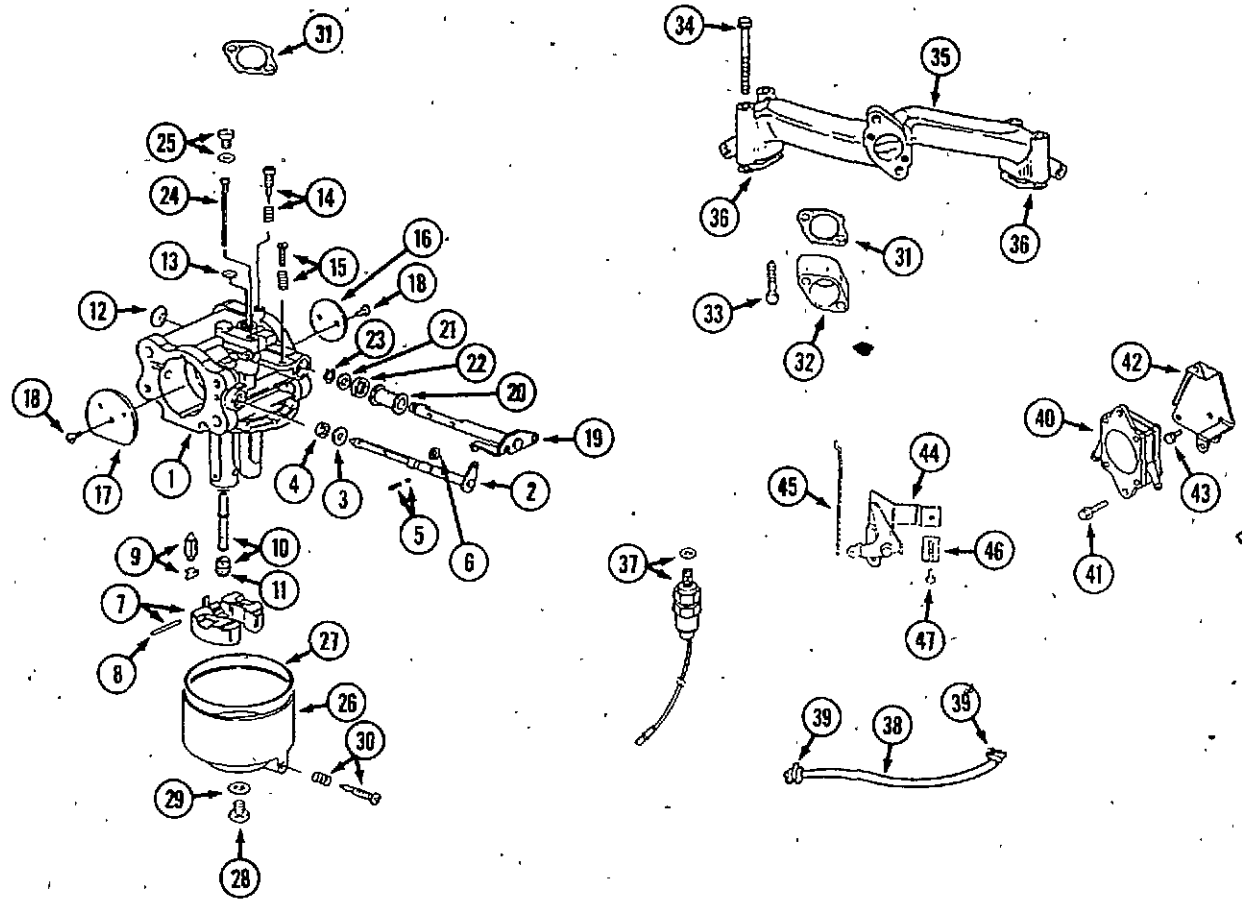

**CARBURETOR; MANIFOLD AND FUEL PUMP**

1	C 34392	CARBURETOR	1
2	NSS	BODY - carburetor	1
3	C 34396	KIT - choke shaft	1
4	NSS	COLLAR - choke shaft (use overhaul kit)	1
5	NSS	SEAL - choke shaft (use overhaul or gasket kit)	1
6	NSS	BALL - locator (use overhaul kit)	1
7	NSS	RETAINER - shaft (use overhaul kit)	1
8	C 34395	FLOAT - fuel	1
9	NSS	PIN - float hinge (use overhaul kit)	1
10	NSS	VALVE - fuel inlet (use overhaul kit)	1
11	NSS	NOZZLE - (use overhaul kit)	1
12	NSS	JET - main (use overhaul kit)	1
13	NSS	PLUG - welch (use overhaul kit)	1
14	NSS	PLUG - welch (use overhaul kit)	1
15	C 34388	VALVE - idle adjust (use overhaul kit)	1
16	C 34393	SCREW AND SPRING - throttle adjust	1
17	C 34389	VALVE - throttle	1
18	C 34387	VALVE - choke	1
19	C 34394	SCREW - mounting	3
20	NSS	KIT - throttle shaft	1
21	NSS	COLLAR - throttle (use overhaul kit)	1
22	NSS	COLLAR - throttle (use overhaul kit)	1
23	NSS	SEAL - throttle shaft (use overhaul or gasket kit)	1
24	NSS	RETAINER - throttle shaft (use overhaul kit)	1
25	NSS	NOZZLE - fuel (use overhaul kit)	1
26	C 34410	PLUG - nozzle	1
27	C 34411	BOWL ASSEMBLY	1
28	NSS	GASKET - bowl (use overhaul or gasket kit)	1
29	C 34409	SCREW - bowl mounting	1
30	NSS	GASKET - sealing (use overhaul or gasket kit)	1
31	C 34399	DRAIN - bowl	1
32	C 34385	GASKET - mounting	2
33	C 34391	SPACER - carburetor	1
34	C 34386	BOLT - mounting	2
35	C 34236	BOLT - manifold	4
36	C 34232	MANIFOLD - intake	1
37	C 34234	GASKET - manifold	2
38	C 34408	SOLENOID - fuel shut off	1
39	NSS	HOSE - fuel (use C28937 cut to length)	1
40	214- 251	CLAMP - hose	1
41	C 34300	PUMP - fuel	1
42	C 34339	SCREW - mounting	2
43	C 34404	BRACKET - fuel pump	1
44	C 34281	SCREW - bracket	2
45	C 34274	BRACKET - choke control	1
46	C 34268	LINK - choke	1
47	BR221535	CLAMP - casing	1
	C 34292	SCREW - clamp	1
	C 34412	KIT - carburetor gaskets (includes Ref. 5, 23, 28 and 30)	1
	C 34390	KIT - carburetor overhaul	1

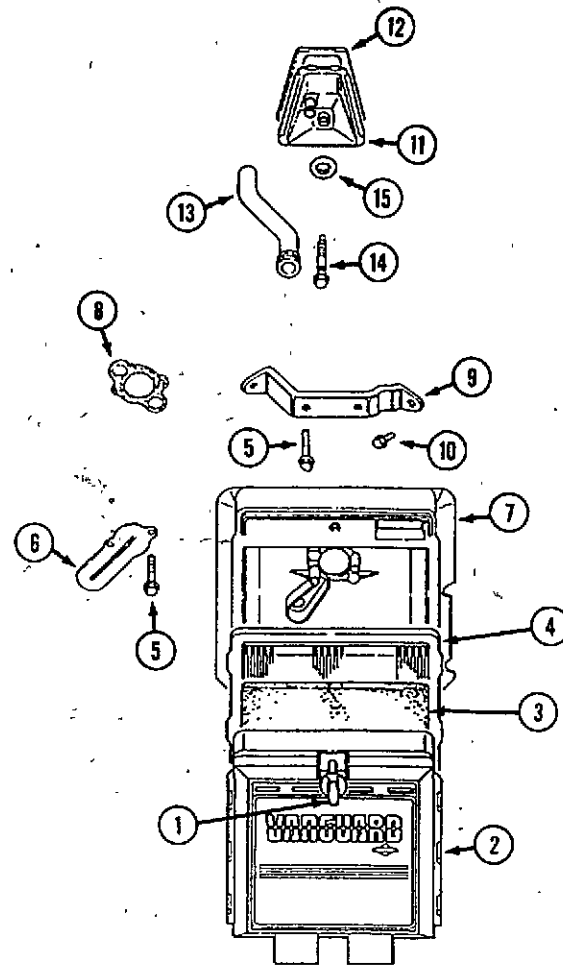

## AIR CLEANER AND CRANKCASE BREATHER

REF.	PART NO.	DESCRIPTION	REQ'D
1	C 34359	SCREW - mounting	1
2	C 34358	COVER - air cleaner	1
3	C 34363	PRECLEANER	1
4	C 34357	FILTER - air	1
5	C 34360	BOLT - mounting	2
6	C 34366	DEFLECTOR - breather	1
7	C 34356	BASE - air cleaner	1
8	C 34312	GASKET - air cleaner	1
9	C 34407	BRACKET - air cleaner	1
10	C 34279	SCREW - bracket	2
11	C 34381	BREATHER ASSEMBLY	1
12	C 34198	GASKET - breather	1
13	C 34200	TUBE - breather	1
14	C 34382	SCREW - mounting	1
15	C 34329	SEAL - breather screw	1

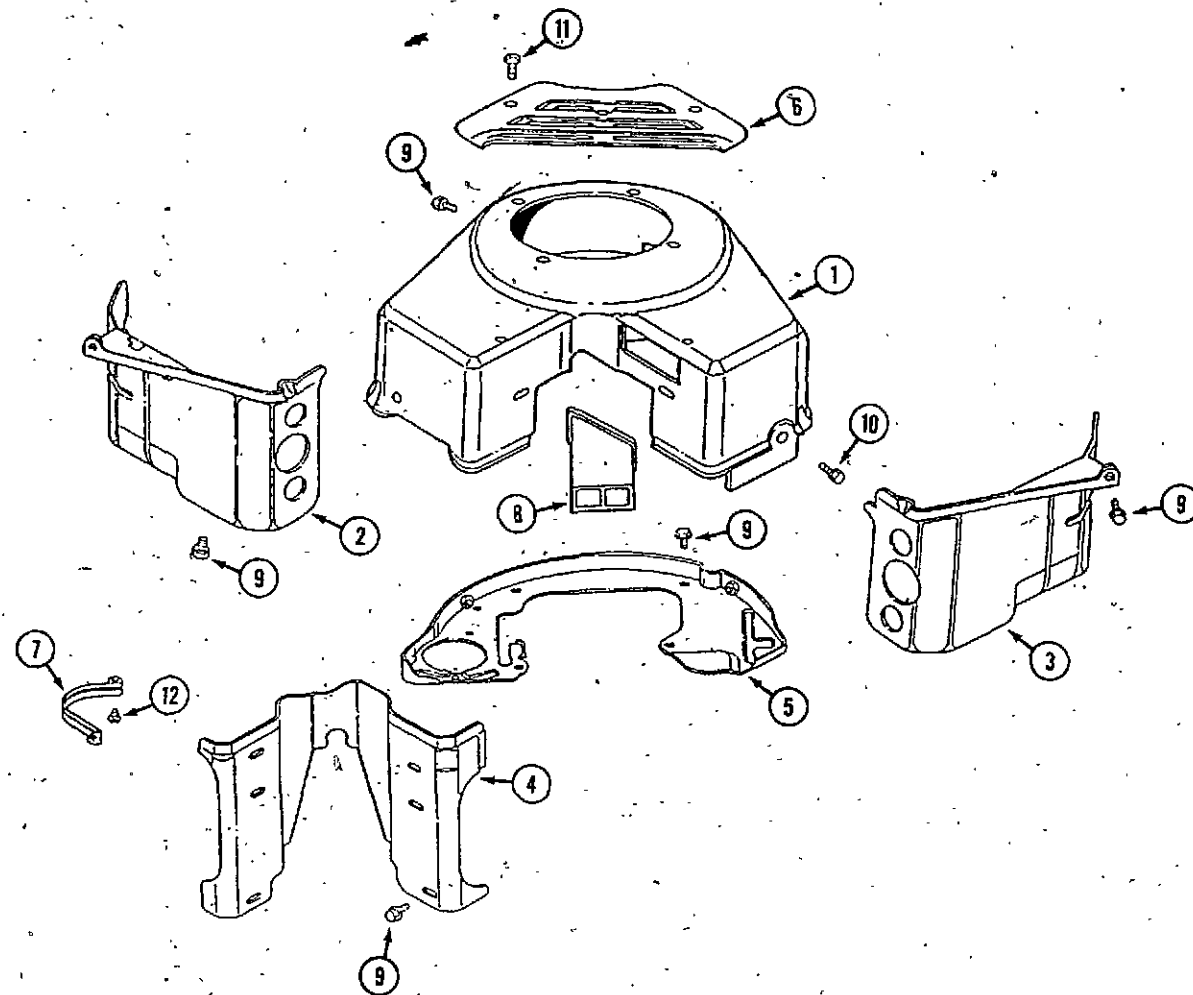

## BLOWER HOUSING AND ENGINE AIR GUIDES

REF.	PART NO.	DESCRIPTION	REQ'D
1	C 34278	HOUSING - blower	1
2	C 34282	COVER - air guide (cyl. #1)	1
3	C 34283	COVER - air guide (cyl. #2)	1
4	C 34345	COVER - valley	1
5	C 34318	PLATE - back	1
6	C 34350	COVER - carburetor	1
7	C 34332	SHIELD - stator	1
8	C 34365	TUBE - air inlet	1
9	C 34279	SCREW - mounting	UAR
10	C 34281	SCREW - blower housing	UAR
11	C 34325	SCREW - carburetor cover	2
12	C 34301	SCREW - shield, starter	2

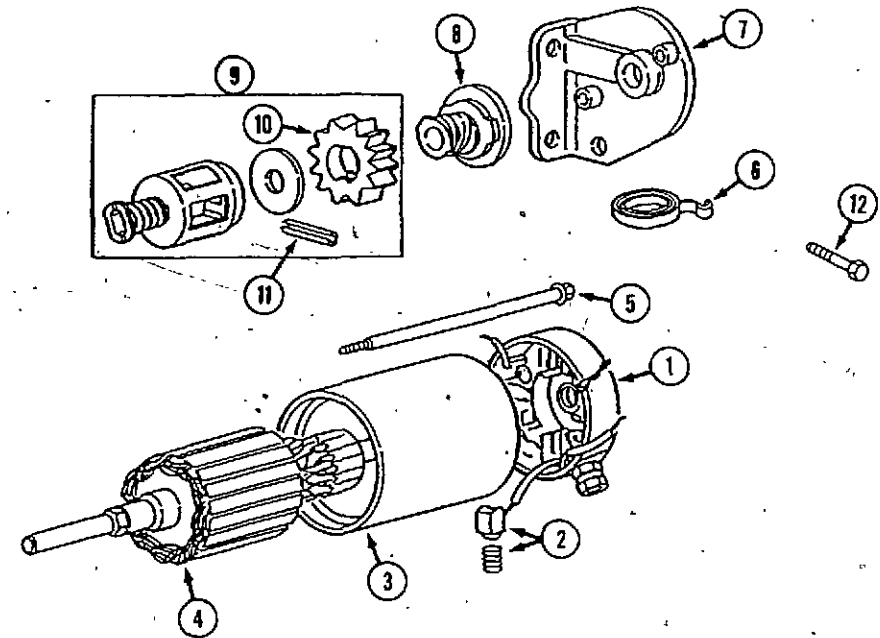
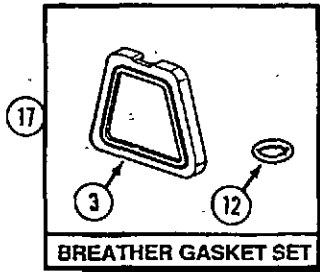
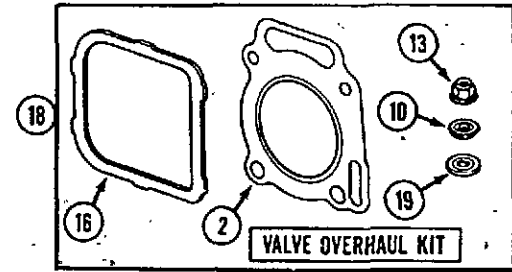
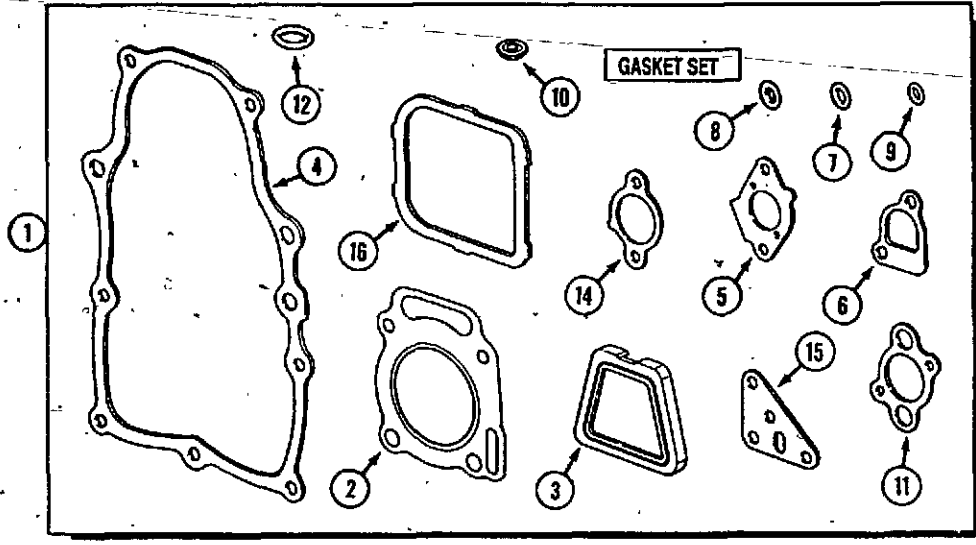

**GASKET SETS**

REF.	PART NO.	DESCRIPTION	REQ'D
1	C 34297	GASKET SET - complete	1
2	C 34196	GASKET - cylinder head	2
3	C 34198	GASKET - breather	1
4	C 34201	GASKET - crankcase	1
5	C 34385	GASKET - carburetor mounting	2
6	C 34234	GASKET - intake manifold	2
7	C 34246	"O" RING - oil pump	UAR
8	C 34247	"O" RING - crankcase cover	UAR
9	NSS	"O" RING - oil pick-up tube	1
10	C 34261	WASHER - valve cover	4
11	C 34312	GASKET - air cleaner	1
12	C 34329	SEAL - breather screw	1
13	C 34262	NUT - lock, valve cover	4
14	C 34351	GASKET - exhaust	2
15	C 34361	GASKET - oil filter adapter	1
16	C 34367	GASKET - valve cover	2
17	C 34249	BREATHER GASKET SET - includes Ref. 3, 12	1
18	C 34279	VALVE OVERHAUL GASKET KIT - includes Ref. 2, 10, 16, 19, 20	1
19	C 34195	WASHER - cylinder head bolt	8

**STARTER**

1	C 34284	STARTER - 12 volt	1
2	C 34336	CAP ASSEMBLY - commutator end	1
3	C 34286	BRUSH ASSEMBLY	4
4	C 34405	HOUSING - starter	1
5	C 34313	ARMATURE - starter	1
6	C 34285	BOLT - thru	2
7	C 34364	SPRING - brush	4
8	C 34335	CAP ASSEMBLY - drive end	1
9	C 30406	CLUTCH - drive	1
10	C 27424	KIT - retainer	1
11	C 27422	GEAR - drive	1
12	C 34353	PIN - roll	1
	C 34263	BOLT - starter mounting	2

## NUMERICAL INDEX

PART NO.	PAGE NO.	REF. NO.	PART NO.	PAGE NO.	REF. NO.
BR221535	37	23	C34210	33	5
BR221535	39	46	C34211	33	4
BR221798	33	2	C34212	33	12
C11205	31	31	C34213	33	12
C14399	37	14	C34214	33	12
C14906	37	13	C34215	33	12
C19310	31	14	C34216	33	13
C19316	31	78	C34217	33	13
C19345	31	29	C34218	33	13
C19347	31	27	C34219	33	13
C19352	31	28	C34220	33	15
C19353	31	38	C34221	33	14
C19354	31	37	C34222	33	16
C19357	31	40	C34223	33	17
C19358	31	43	C34224	35	34
C19473	37	12	C34225	35	35
C27422	45	10	C34226	35	36
C27424	45	9	C34228	35	37
C27553	31	7	C34229	35	10
C27555	31	53	C34230	35	32
C27556	31	58	C34231	33	2
C27562	31	6	C34232	39	35
C27563	31	36	C34234	39	36
C27565	31	35	C34234	45	6
C27570	31	33	C34236	39	34
C27588	31	64	C34237	33	8
C28648	31	32	C34238	33	11
C28649	31	2	C34239	35	5
C28650	31	39	C34239	37	8
C28651	31	46	C34240	37	11
C28652	31	12	C34246	35	12
C28653	31	34	C34246	45	7
C28654	31	22	C34247	37	5
C28656	31	53A	C34247	45	8
C28657	31	52	C34249	45	17
C28658	31	50	C34259	35	29
C28660	31	55	C34260	37	15
C28661	31	57	C34261	35	25
C28662	31	59	C34261	45	10
C28663	31	65	C34262	35	24
C28664	31	30	C34262	45	13
C28667	31	20	C34263	45	12
C28821	31	68	C34264	37	16
C30406	45	8	C34265	35	31
C30500	31	13	C34266	37	19
C34144	31	44	C34267	37	17
C34147	31	25	C34268	39	45
C34147	31	42	C34269	37	21
C34148	31	21	C34270	37	13
C34149	31	71	C34271	37	20
C34156	31	26	C34274	39	44
C34191	35	2	C34275	37	15
C34192	35	3	C34278	43	1
C34193	35	14	C34279	41	10
C34194	35	15	C34279	43	9
C34195	35	21	C34281	37	22
C34195	45	19	C34281	39	43
C34196	35	19	C34281	43	10
C34196	45	2	C34282	43	2
C34198	41	12	C34283	43	3
C34198	45	3	C34284	45	
C34200	41	13	C34285	45	5
C34201	37	3	C34286	45	2
C34201	45	4	C34287	33	10
C34202	35	20	C34288	33	7
C34203	37	7	C34289	33	1
C34208	37	2	C34290	33	3
C34209	37	6	C34290	33	8

PART NO.	PAGE NO.	REF. NO.	PART NO.	PAGE NO.	REF. NO.
C34291	33	4	C34291	33	4
C34292	33	11	C34292	33	11
C34292	37	24	C34292	37	24
C34292	39	47	C34292	39	47
C34293	33	12	C34293	33	12
C34297	45	1	C34297	45	1
C34300	39	40	C34300	39	40
C34301	43	12	C34301	43	12
C34303	33	9	C34303	33	9
C34304	33	6	C34304	33	6
C34306	33	10	C34306	33	10
C34310	33	7	C34310	33	7
C34312	41	8	C34312	41	8
C34312	45	11	C34312	45	11
C34313	21	47	C34313	21	47
C34313	45	4	C34313	45	4
C34314	37	9	C34314	37	9
C34315	37	10	C34315	37	10
C34316	37	14	C34316	37	14
C34317	35	8	C34317	35	8
C34318	43	5	C34318	43	5
C34319	37	16	C34319	37	16
C34321	37	12	C34321	37	12
C34322	37	8	C34322	37	8
C34323	37	4	C34323	37	4
C34324	33	5	C34324	33	5
C34325	43	11	C34325	43	11
C34326	33	9	C34326	33	9
C34327	35	6	C34327	35	6
C34328	35	7	C34328	35	7
C34329	41	15	C34329	41	15
C34329	45	12	C34329	45	12
C34331	33	6	C34331	33	6
C34332	43	7	C34332	43	7
C34335	45	7	C34335	45	7
C34336	45	1	C34336	45	1
C34338	35	13	C34338	35	13
C34339	37	5	C34339	37	5
C34339	39	41	C34339	39	41
C34342	35	9	C34342	35	9
C34345	43	4	C34345	43	4
C34346	35	33	C34346	35	33
C34347	35	17	C34347	35	17
C34348	35	16	C34348	35	16
C34349	35	18	C34349	35	18
C34350	43	6	C34350	43	6
C34351	45	14	C34351	45	14
C34353	45	11	C34353	45	11
C34356	41	7	C34356	41	7
C34357	41	4	C34357	41	4
C34358	41	2	C34358	41	2
C34359	41	1	C34359	41	1
C34360	41	5	C34360	41	5
C34361	37	9	C34361	37	9
C34361	45	15	C34361	45	15
C34362	37	10	C34362	37	10
C34363	41	3	C34363	41	3
C34364	45	6	C34364	45	6
C34365	43	8	C34365	43	8
C34366	41	6	C34366	41	6
C34367	35	23	C34367	35	23
C34367	45	16	C34367	45	16
C34368	35	22	C34368	35	22
C34369	35	22	C34369	35	22
C34371	33	1	C34371	33	1
C34372	35	26	C34372	35	26
C34373	35	26	C34373	35	26
C34374	37	6	C34374	37	6

## NUMERICAL INDEX

PART NO.	PAGE NO.	REF. NO.	PART NO.	PAGE NO.	REF. NO.
C34375	37	7	C34516	15	1
C34376	35	30	C34537	19	1
C34377	35	27	C34794	5	25
C34378	35	28	C34794	5	27
C34379	45	18	C34794	7	75
C34380	35	1	C34796	7	68
C34381	41	11	C34796	15	18
C34382	41	14	C34796	23	27
C34383	33	3	C34796	23	36
C34384	37	1	C34798	5	11
C34385	39	31	C34798	5	18
C34385	45	5	C34798	5	50
C34386	39	33	C34798	7	67
C34387	39	18	C34798	7	69
C34388	39	15	C34798	7	78
C34389	39	17	C34798	9	4
C34390	39		C34798	9	25
C34391	39	32	C34798	9	30
C34392	39		C34798	9	33
C34393	39	16	C34798	9	37
C34394	39	19	C34798	9	39
C34395	39	7	C34798	9	42
C34396	39	2	C34798	13	4
C34397	37	18	C34798	13	9
C34398	35	4	C34798	15	8
C34399	39	30	C34798	15	14
C34400	35	11	C34798	15	17
C34401	37	3	C34798	15	20
C34402	37	2	C34798	15	25
C34403	37	1	C34798	15	29
C34404	39	42	C34798	17	63
C34405	45	3	C34798	17	74
C34406	37	4	C34798	17	83
C34407	41	9	C34798	17	86
C34408	39	37	C34798	21	4
C34409	39	28	C34798	21	6
C34410	39	25	C34798	21	9
C34411	39	26	C34798	21	13
C34412	39		C34798	21	17
C34486	31	1	C34798	21	35
C34487	31	3	C34798	21	38
C34488	31	4	C34798	21	43
C34489	31	5	C34798	21	46
C34490	31	8	C34798	21	50
C34491	31	9	C34798	23	29
C34492	31	10	C34798	23	33
C34493	31	11	C34798	23	38
C34494	31	15	C34800	9	9
C34495	31	17	C34800	9	19
C34496	31	18	C34800	15	10
C34498	31	41	C34802	7	76
C34499	31	45	C34802	13	7
C34500	31	47	C34802	15	12
C34501	31	48	C34802	21	41
C34502	31	49	C34806	9	13
C34503	31	51	C34806	9	16
C34504	31	54	C34806	9	60
C34505	31	56	C34806	15	32
C34506	31	60	C34806	23	31
C34507	31	61	C34806	25	18
C34508	31	62	C34808	7	72
C34509	31	66	C34808	19	12
C34510	31	67	C34814	5	16
C34511	31	69	C34814	15	40
C34512	31	70	C34814	15	44
C34513	31	75	C34814	17	78
C34514	31	76	C34814	29	12
C34515	31	77	C34816	7	66

PART NO.	PAGE NO.	REF. NO.	PART NO.	PAGE NO.	REF. NO.
C34816	17	81	C34816	17	81
C34817	5	17	C34817	5	17
C34824	9	73	C34824	9	73
C34825	9	72	C34825	9	72
C34826	9	74	C34826	9	74
C34828	29	13	C34828	29	13
C34833	17	85	C34833	17	85
C34833	25	24	C34833	25	24
C34834	5	28	C34834	5	28
C34834	5	31	C34834	5	31
C34839	29	9	C34839	29	9
C34848	5	24	C34848	5	24
C34856	21	5	C34856	21	5
C34856	29	5	C34856	29	5
C34857	9	29	C34857	9	29
C34861	11	10	C34861	11	10
C34861	13	48	C34861	13	48
C34861	23	21	C34861	23	21
C34873	15	2	C34873	15	2
C34874	15	4	C34874	15	4
C34876	9	3	C34876	9	3
C34876	13	3	C34876	13	3
C34876	13	8	C34876	1	



NUMERICAL INDEX

PART NO.	PAGE NO.	REF. NO.	PART NO.	PAGE NO.	REF. NO.	PART NO.	PAGE NO.	REF. NO.
C34960	21	21	C35082	5	26	C35143	9	40
C34965	19	28	C35083	5	29	C35144	9	43
C34966	19	29	C35083	5	32	C35145	9	44
C34968	9	52	C35084	5	30	C35145	9	48
C34971	19	5	C35085	5	33	C35146	9	45
C34979	11	34	C35086	5	34	C35147	9	47
C34979	17	69	C35087	5	35	C35148	9	50
C34980	17	66	C35088	5	36	C35149	9	51
C34983	21	24	C35089	5	37	C35150	9	53
C34983	21	27	C35090	5	38	C35151	9	54
C34985	21	25	C35091	5	39	C35152	9	55
C34989	21	30	C35092	5	40	C35153	9	56
C34990	21	31	C35093	5	41	C35154	9	57
C34991	21	32	C35094	5	42	C35155	9	61
C34992	21	33	C35095	5	43	C35156	9	62
C34993	17	80	C35096	5	44	C35157	9	63
C34997	5	15	C35097	5	45	C35158	9	64
C34997	21	52	C35098	5	46	C35159	9	65
C34998	21	53	C35100	5	48	C35160	9	66
C35006	9	32	C35100	5	52	C35161	9	67
C35006	9	41	C35100	19	27	C35162	9	68
C35006	15	23	C35101	5	49	C35163	9	70
C35006	21	11	C35102	5	51	C35164	9	75
C35006	21	15	C35103	5	53	C35165	9	76
C35006	21	19	C35104	5	54	C35166	9	77
C35011	19	39	C35105	5	55	C35167	11	2
C35016	25	15	C35106	5	56	C35168	11	3
C35017	25	13	C35107	5	57	C35169	11	4
C35021	25	10	C35110	7	64	C35170	11	5
C35022	25	16	C35111	7	65	C35171	11	7
C35023	25	17	C35112	7	70	C35172	11	8
C35024	25	19	C35112	7	85	C35173	11	9
C35024	25	36	C35113	7	71	C35174	11	11
C35030	25	2	C35113	7	83	C35174	23	22
C35030	25	6	C35114	7	73	C35175	11	12
C35032	25	34	C35115	7	74	C35176	11	13
C35033	25	23	C35116	7	77	C35177	11	14
C35035	25	4	C35117	7	79	C35178	11	15
C35036	25	37A	C35118	7	80	C35180	11	17
C35049	27	2	C35119	7	81	C35181	11	20
C35050	27	1	C35120	7	82	C35182	11	21
C35052	27	19	C35120	7	84	C35182	13	40
C35053	29	7	C35123	9	1	C35183	11	22
C35054	15	11	C35124	9	2	C35184	11	23
C35054	15	16	C35124	9	23	C35185	11	24
C35054	29	4	C35124	9	35	C35185	19	18
C35064	5	1	C35124	9	38	C35186	11	25
C35065	5	2	C35124	17	61	C35187	11	28
C35066	5	3	C35125	9	5	C35188	11	29
C35067	5	4	C35126	9	6	C35189	11	30
C35068	5	5	C35127	9	8	C35190	11	31
C35069	5	6	C35128	9	10	C35191	11	32
C35070	5	7	C35129	9	11	C35192	11	33
C35071	5	8	C35129	9	58	C35192	17	68
C35071	11	18	C35129	9	69	C35193	11	37
C35071	19	10	C35130	9	12	C35194	11	38
C35072	5	9	C35130	9	59	C35195	11	40
C35072	11	19	C35131	9	14	C35196	13	1
C35072	19	11	C35132	9	15	C35198	13	5
C35073	5	10	C35133	9	17	C35199	13	6
C35074	5	12	C35134	9	18	C35200	13	10
C35075	5	13	C35136	9	21	C35201	13	11
C35076	5	14	C35137	9	22	C35202	13	12
C35077	5	19	C35139	9	24	C35203	13	13
C35078	5	20	C35139	21	40	C35204	13	14
C35079	5	21	C35140	9	28	C35205	13	15
C35080	5	22	C35141	9	31	C35206	13	16
C35081	5	23	C35142	9	34	C35207	13	17

NUMERICAL INDEX

PART NO.	PAGE NO.	REF. NO.	PART NO.	PAGE NO.	REF. NO.	PART NO.	PAGE NO.	REF. NO.
C35208	13	18	C35271	19	13	C35336	25	8
C35209	13	19	C35272	19	14	C35337	25	9
C35210	13	20	C35273	19	15	C35338	25	11
C35211	13	21	C35274	19	16	C35339	25	12
C35212	13	22	C35275	19	17	C35340	25	14
C35213	13	24	C35277	19	20	C35342	25	25
C35214	13	25	C35278	19	21	C35343	25	26
C35215	13	27	C35279	19	22	C35344	25	28
C35216	13	28	C35280	19	25	C35345	25	29
C35217	13	29	C35281	19	26	C35346	25	30
C35218	13	30	C35282	19	30	C35347	25	31
C35219	11	16	C35283	19	31	C35348	25	32
C35219	13	31	C35284	19	32	C35349	25	33
C35220	13	32	C35284	23	11	C35350	25	35
C35221	13	34	C35285	19	33	C35351	25	37B
C35221	13	43	C35286	19	34	C35352	27	4
C35221	13	49	C35287	19	35	C35353	27	5
C35222	13	35	C35288	19	36	C35354	27	6
C35223	13	36	C35289	19	37	C35355	27	7
C35224	13	37	C35290	19	38	C35356	27	8
C35225	13	38	C35290	23	13	C35357	27	9
C35226	13	39	C35291	19	40	C35358	27	10
C35227	13	41	C35292	19	41	C35359	27	11
C35229	13	44	C35293	21	1	C35360	27	12
C35230	13	45	C35294	21	2	C35361	27	13
C35231	13	46	C35295	21	3	C35362	27	15
C35232	13	47	C35295	21	8	C35363	27	16
C35233	15	5	C35295	21	37	C35364	27	17
C35234	13	2	C35295	21	45	C35365	27	18
C35234	15	6	C35295	21	49	C35366	29	1
C35235	15	9	C35296	21	7	C35367	29	2
C35236	15	15	C35297	21	10	C35368	29	6
C35237	15	19	C35298	21	14	C35369	29	8
C35238	15	21	C35299	21	18	C35370	29	10
C35239	15	22	C35300	21	22	C35371	29	11
C35239	15	26	C35301	21	23	C35372	29	14
C35240	15	24	C35302	21	26	C35373	29	15
C35240	15	28	C35303	21	28	C35380	5	47
C35240	23	10	C35304	21	29	C35426	15	34
C35241	15	27	C35307	21	34	C35458	23	17
C35242	15	30	C35308	21	36	C35568	19	19
C35243	15	31	C35309	21	39	C35640	25	21
C35244	15	33	C35311	21	42	C35641	13	42
C35246	15	36	C35312	21	44	C39947	31	23
C35247	15	37	C35314	21	48	214 - 251	39	39
C35248	15	38	C35315	21	51	221 - 86	37	11
C35249	15	39	C35316	23	2			
C35249	15	42	C35317	23	4			
C35250	15	41	C35318	23	8			
C35251	17	60	C35319	23	9			
C35253	17	64	C35319	23	20			
C35254	17	65	C35320	23	12			
C35255	17	67	C35322	23	14			
C35256	17	70	C35323	23	15			
C35257	17	71	C35324	23	16			
C35258	17	72	C35326	23	18			
C35259	17	79	C35327	23	19			
C35260	17	84	C35328	23	23			
C35261	17	87	C35329	23	30			
C35262	17	90	C35330	23	34			
C35263	17	92	C35331	23	35			
C35264	19	2	C35332	25	1			
C35265	19	3	C35333	25	3			
C35266	19	4	C35334	9	20			
C35267	19	6	C35334	25	5			
C35268	19	7	C35334	25	22			
C35269	19	8	C35334	25	27			
C35270	19	9	C35335	25	7			