

**COMPACT TRACTOR  
1112H  
Parts Catalog 8-3170**

5-91-RP-500-212

**ALPHABETICAL INDEX**

**TRACTOR**

	<b>Page</b>	<b>Grid</b>		<b>Page</b>	<b>Grid</b>
Chassis and Hood .....	5-7	A6-A8	Motion Drive .....	13-15	A14-B2
Customer Assembly .....	27	B14	Mower Deck .....	19-21	B6-B8
Decals .....	25	B12	Mower Suspension .....	9	A10
Electrical .....	23	B10	Steering .....	11	A12
Engine and Control .....	17	B4	Transaxle .....	29	C2
Hydrostatic Pump .....	31	C4			

**ENGINE**

	<b>Page</b>	<b>Grid</b>		<b>Page</b>	<b>Grid</b>
Carburetor .....	37	C10	Governor .....	39	C12
Counterweight .....	35	C8	Oil Filler .....	39	C12
Engine Block .....	33	C6	Starter .....	41	C14
Flywheel and Stator .....	35	C8			

## GENERAL INFORMATION

### INDEX

There is an index at the front and rear of this catalog.

The front index is an alphabetical index of the major groups or assemblies.

The rear index is a numerical index of the part numbers and pages on which these numbers are shown.

### ILLUSTRATION

Each illustration in this catalog shows a group of parts or components. These parts and components are aligned approximately as the parts and components on your machine. Each part and component in an illustration has a reference number. These reference numbers are in a list on the page opposite of the illustration. Next to the reference number is the part number, description and required quantity of the part shown in the illustration.

UAR - "Use as required" indicates that the part quantity is variable.

NSS - "Not sold separately" indicates that the part is only available as a component of an assembly or the part must be purchased locally. If the part is an assembly component, the description will be indented under the assembly description in the parts list.

O/L - "Obtain locally"

\*\* - "Footnotes" are added to a part number when more information is needed for identification. They only relate to the part numbers indicated.

### PARTS ORDERS

All orders must include the following information:

1. Correct part number.
2. Complete description of part or component.
3. Total quantity of each part or component.
4. Product model number.
5. All necessary product identification numbers.
6. Method for sending the parts.
7. Complete and correct address.

### CATALOG REVISIONS

As the product changes, new pages will be available for your catalog. A notice will be issued.

**IMPORTANT:** Put all revisions into the catalog as soon as possible.

### RIGHT HAND AND LEFT HAND IDENTIFICATION

The words right hand (RH) and left hand (LH) as used in this catalog indicate the direction while you are in the operator's seat in the normal operating position.

### INDENTED DESCRIPTIONS

An assembly can have many components. The components of an assembly are indicated by an indented description. The quantity for an indented part is the total needed for that complete assembly. See the example.

REF.	PART NO.	DESCRIPTION	REQ'D
	C 55159	CYLINDER ASSY - rear steering .....	1
28	C 56208	SOCKET ASSY - rear cylinder .....	1
29	C 55956	PLUG - adjusting, socket assy .....	1
30	C 55957	SEAT - socket ball .....	2
31	C 56210	SPRING - socket .....	1
32	C 56209	SEAT - socket spring .....	1
33	G 45175	CLAMP ASSY - socket assy .....	1
	16- 836	BOLT - 1/2" x 2-1/4" N.F. hex .....	1
34	132- 104	PIN - cotter, 3/16" x 3" .....	1
35	C 55889	STUD - ball, socket & cylinder .....	2
36	13- 410	BOLT - 1/4" x 5/8" N.C., hex .....	4
37	92- 4	LOCK WASHER - 1/4" SAE .....	4

# INGERSOLL

Ingersoll Equipment Co., Inc.

CHASSIS AND HOOD ASSEMBLY

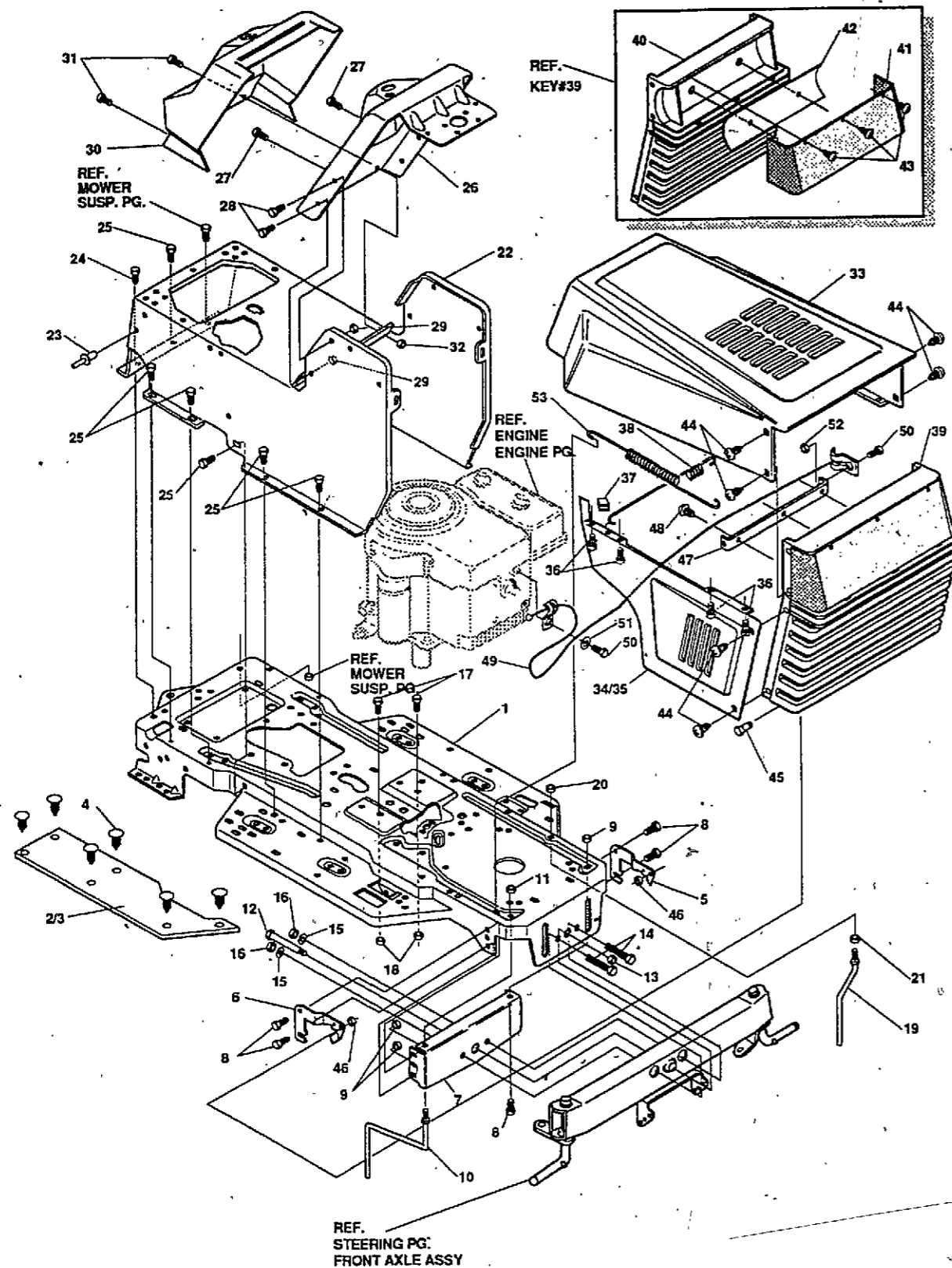

key#	part#	description	qty.
1	C35064	FRAME,LF MAIN P920/F4360	1
2	C35065	FOOTPAD,LH	1
3	C35066	FOOTPAD,RH	1
4	C35067	FASTENER, RATCHET	12
5	C35068	BRKT.GRILLE, L.H.	1
6	C35069	BRKT GRILLE R.H.	1
7	C35070	BRACKET, FRONT AXLE	1
8	C35071	SCREW, 5/16-18X.75WDFLLK	5
9	C35072	NUT, 5/16-18 HXWDFLLK	5
10	C35073	GUIDE, BELT, RIDER	1
11	C34798	NUT, 5/16-18 REGHEXCTRLK	1
12	C35374	BOLT, .625X2.180 HSSH 1/2-13NC	1
13	C35375	NUT, 1/2-13 REGHCTRLK	1
14	C35076	SCREW, 3/8-16X3.00 HHC	2
15	C34997	WASHER, .39IDX1.25DX.07 BELLVIL	2
16	C34814	NUT, 3/8-16 REGHCTRLK	2
17	C34817	SCREW, 5/16-18X .88 HHC	2
18	C34798	NUT, 5/16-18 REGHEXCTRLK	2
19	C35077	GUIDE,BELT SHORT 15" WHEEL	1
20	C35078	NUT, 5/16-18 HEXJAM	1
21	C35079	NUT, 3/8-16 HEXKEPS	1
22	C35080	CONSOLE	1
23	C35081	RIVET, POP .187DIA X .450LG ST	1
24	C34848	SCREW, 5/16-18X .50 WAHTAP	1
25	C34794	SCREW, 1/4-20X .50 WAHTAP	12
26	C35082	DASH	1
27	C34794	SCREW, 1/4-20X .50 WAHTAP	2
28	C34834	SCREW, 1/4-20X .63 HHWATAP	4
29	C35083	NUT, 1/4-20 WDFLLK TOPLOCK	4
30	C35377	DASH	1
31	C34834	SCREW, 1/4-20X .63 HHWATAP	2
32	C35083	NUT, 1/4-20 WDFLLK TOPLOCK	2
33	C35379	HOOD	1
34	C35087	PANEL,SIDE,HOOD,LH	1
35	C35088	PANEL,SIDE,HOOD RH	1
36	C35089	SCREW, 10-16X .50 WAHTAP	8
37	C35090	CLIP, U-TYPE, TINNEMAN	2
38	C35091	SPRING, HOOD SINGLE CYL	1
39	C35095	ASSY,GRILLE	1
40	C35096	GRILLE	1
41	C35097	LENS	1
42	C35098	DECAL, REFLECTOR,GRILLE	1
43	C35380	SCREW, #6 X .50 PLASTITE	3
44	C35100	SCREW, 1/4-10X .75PHPNTAP	8
45	C35101	BOLT, .375X .500 HSSH 5/16-18	2
46	C34798	NUT, 5/16-18 REGHEXCTRLK	2
47	C35102	BRACKET GRILLE 2 HOL	1
48	C35100	SCREW, 1/4-10X .75PHPNTAPGR2	3
49	C34381	LANYARD,HOOD 9.16 LG H14	1
50	C35243	SCREW, 1/4-20X .62 HHC	2
51	C35568	WASHER, REGSPTLK.263X.49X.07	1
52	C34806	NUT, 1/4-20 REGHEXCTRLK	1
53	C35382	SPRING, HOOD LATCH	1

## CHASSIS AND HOOD ASSEMBLY

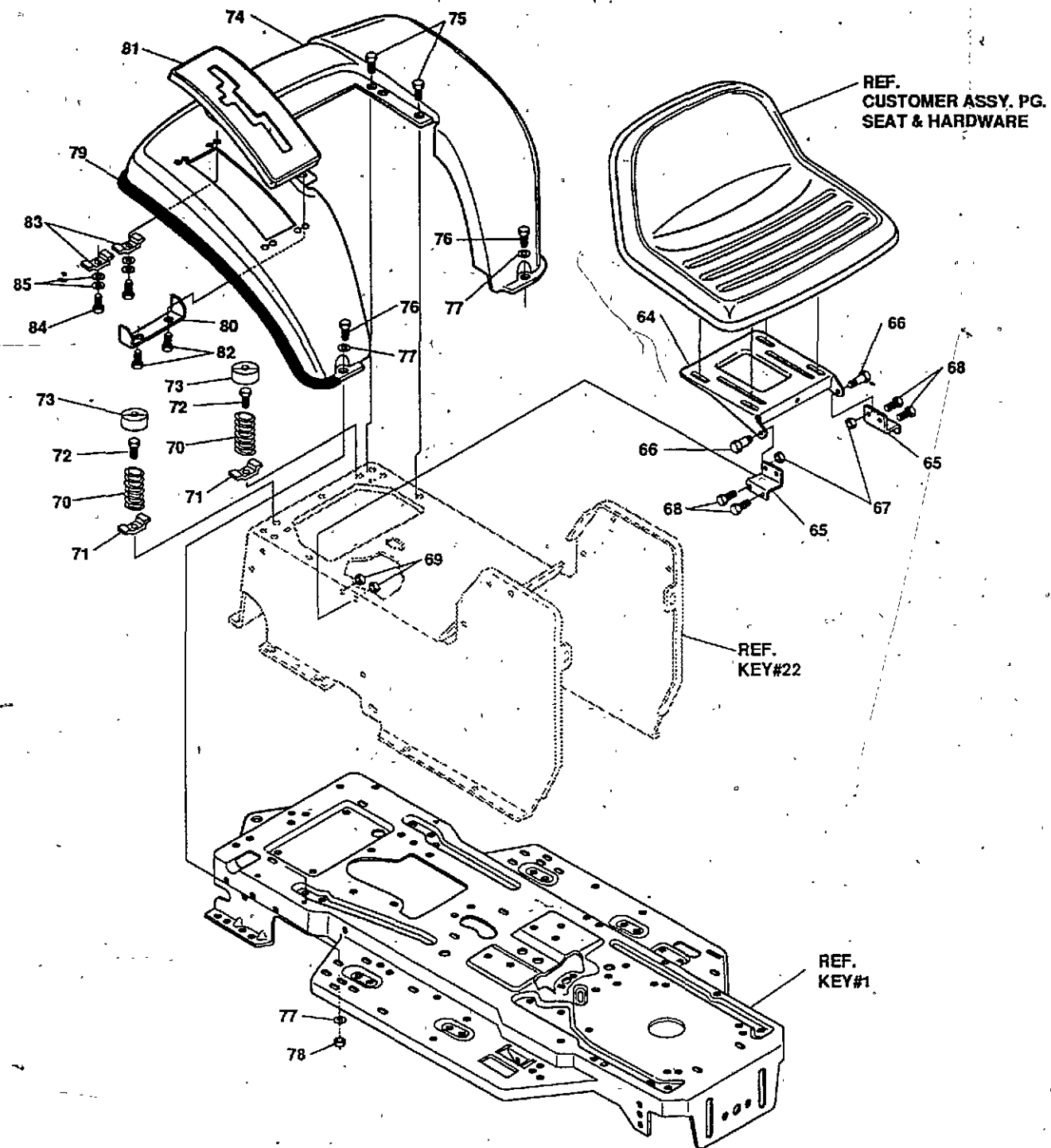

key#	part#	description	qty.
64	C35384	PLATE, SEAT	1
65	C35115	BRACKET, SEAT SUPPORT	1
66	C34816	BOLT, .437X .156 HSSH 5/16-18	2
67	C34798	NUT, 5/16-18 REGHEXCTRLK	2
68	C34796	SCREW, 5/16-18X .63 HHC	4
69	C34798	NUT, 5/16-18 REGHEXCTRLK	4
70	C35112	SPRING, SEAT 2.63LG, 1.49OD	2
71	C35113	CLAMP, SPRING 1.17"ID	2
72	C34808	SCREW, 1/4-20X .75 HXWATAP	2
73	C35114	COVER, SEAT SPRING 1.5IDX1.0LG	2
74	C35385	FENDER, FDR SHIFT	1
75	C34794	SCREW, 1/4-20X .50 WAHTAP	4
76	C34802	SCREW, 5/16-18X1.00 HHC	2
77	C35116	WASHER, FLAT .375X .88X.082	4
78	C34798	NUT, 5/16-18 REGHEXCTRLK	2
79	C35117	TRIM, STRIP, BLACK	77.5"
80	C35118	BRACKET, COVER	1
81	C35386	COVER PLASTIC LF HYDRO	1
82	C35120	SCREW, 1/4-15X.44/.53 HILOHWA	2
83	C35113	CLAMP, SPRING 1.17"ID	2
84	C35120	SCREW, 1/4-15X.44/.53 HILOHWA	2
85	C35122	WASHER, FLAT .281X .63X.065	2

MOWER SUSPENSION ASSEMBLY

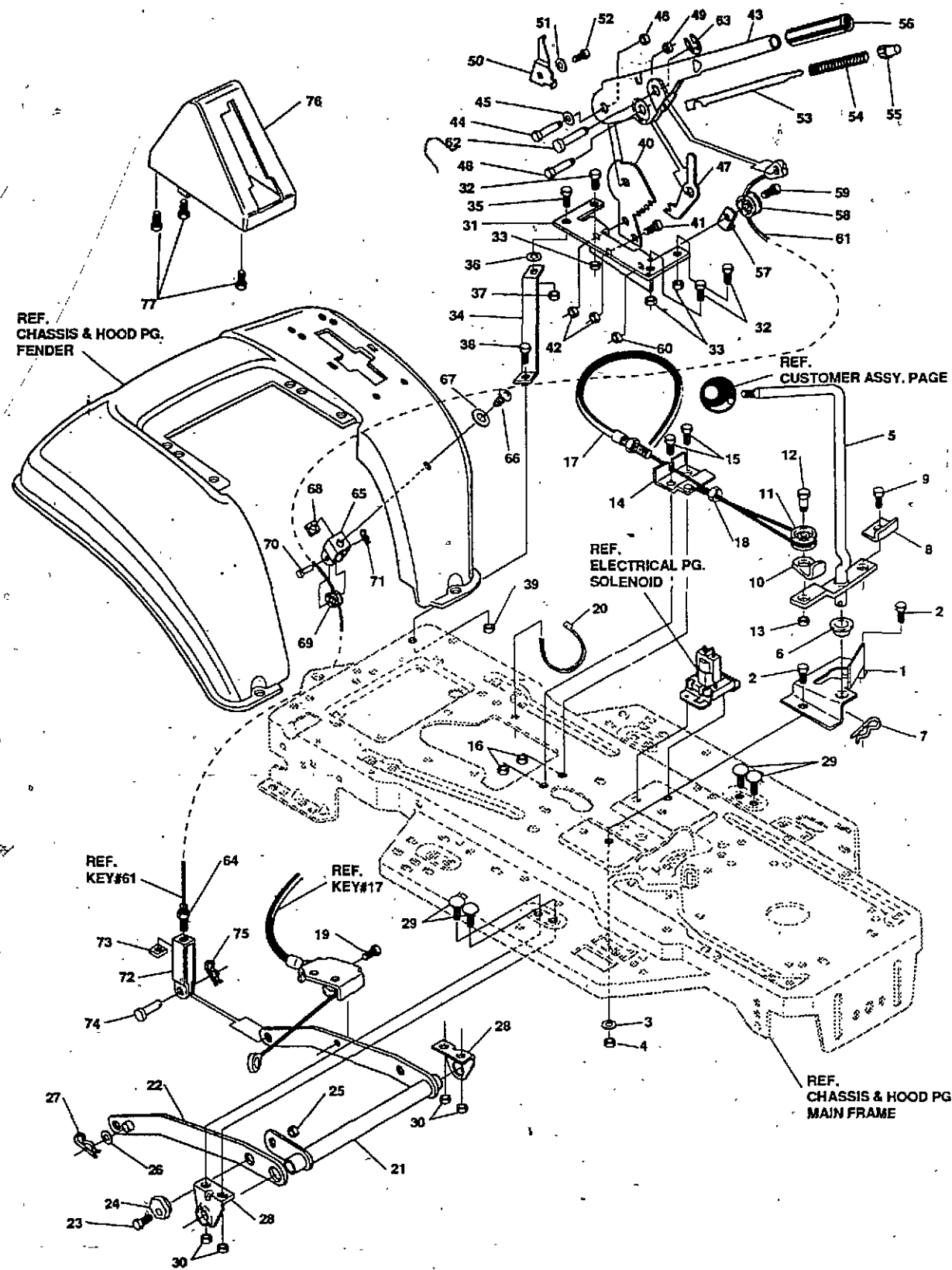

key#	part#	description	qty.
1	C35123	BRACKET,CLUT-ENGAGELEVER	1
2	C35124	SCREW, 5/16-18X1.00 HHC	2
3	C34878	WASHER, FLAT .344X.69X.065	2
4	C34798	NUT, 5/16-18 REGHEXCTRLK	2
5	C35125	ASSY,CLUTCH LEVER	1
6	C35128	BEARING,FL. .503IDX.628OD	1
7	C34908	PIN, HAIR .091 DIA X1.66LG	1
8	C35127	BRACKET, SWITCH ENGAGE	1
9	C34800	SCREW, 5/16-18X.75 WAHHTAP	1
10	C35128	BRKT,CABLE RETAINER	1
11	C35129	PULLEY, .906X.305 NYLON	1
12	C35130	BOLT, .375X.375 HSSH 1/4-20	1
13	C34806	NUT, 1/4-20 REGHEXCTRLK	1
14	C35131	BRKT, FRAME CABLE	1
15	C35132	SCREW, 1/4-20X.75 HHC	2
16	C34806	NUT, 1/4-20 REGHEXCTRLK	2
17	C35133	ASSY,CABLE, BLADE ENGAGE	1
18	C35134	NUT, 1/4-28 HJAM	1
19	C34800	SCREW, 5/16-18X.75 WAHHTAP	1
20	C35334	TIE, CABLE BLACK NYLON	1
21	C35388	ASSY,REAR LIFT	1
22	C35137	ASSY,LINK,RIGHT SIDE	1
23	C35124	SCREW, 5/16-18X1.00 HHC	1
24	C35139	ADJUSTING NUT	1
25	C34798	NUT, 5/16-18 REGHEXCTRLK	1
26	C34892	WASHER, FLAT .531X1.06X.095	2
27	C34908	PIN, HAIR .091 DIA X1.66LG	2
28	C35140	BRKT,REAR,HANG,SUSP.	2
29	C34857	BOLT, 5/16-18X.63 CARR	4
30	C34798	NUT, 5/16-18 REGHEXCTRLK	4
31	C35141	BRACKET,HGT/ADJUST SUPPORT	1
32	C35006	SCREW, 5/16-18X.75 HHC	3
33	C34798	NUT, 5/16-18 REGHEXCTRLK	3
34	C35111	BRACE, FENDER	1
35	C35124	SCREW, 5/16-18X1.00 HHC	1
36	C34899	WASHER, FLAT .333X.87X.119	1
37	C34798	NUT, 5/16-18 REGHEXCTRLK	1
38	C35124	SCREW, 5/16-18X1.00 HHC	1
39	C34798	NUT, 5/16-18 REGHEXCTRLK	1
40	C35143	QUADRANT,HEIGHT ADJUST	1
41	C35006	SCREW, 5/16-18X.75 HHC	2
42	C34798	NUT, 5/16-18 REGHEXCTRLK	2
43	C35144	HANDLE,LIFT SHORT BLK	1
44	C35145	BOLT, .500X.270 HSSH 5/16-18	1
45	C35146	WASHER, FLAT .506X.75X.024	1
46	C34960	NUT, 5/16-18 HWDFLCTRLK	1
47	C35147	PAWL, HEIGHT ADJUST	1
48	C35145	BOLT, .500X.270 HSSH 5/16-18	1
49	C34960	NUT, 5/16-18 HWDFLCTRLK	1
50	C35148	POINTER Z-PL	1
51	C35149	WASHER, EXLK.195X.41X.03	1
52	C34968	SCREW, #8-32X.38 HHWAT	1
53	C35150	ROD,ACTUATOR-SHORT	1
54	C35151	SPRING, HEIGHT ADJUST	1
55	C35152	KNOB,HGT ADJ PUSH BUTTON	1
56	C35153	GRIP, .750 OD W/ HOLE	1
57	C35154	BRKT, CABLE RETAIN	1
58	C35129	PULLEY, .906X.305 NYLON	1
59	C35130	BOLT, .375X.375 HSSH 1/4-20	1
60	C34806	NUT, 1/4-20 REGHEXCTRLK	1
61	C34823	CABLE, LIFT 21.70 F-5 20X8-8	1
62	C34158	PIN,CLEVIS .310DIA+.475LG	1
63	C35157	RING, RET E .31X.24	1
64	C35158	NUT, 1/4-20 REGHEX	1
65	C35159	CLEVIS	1
66	C35160	SCREW, 5/16-18X.56PHPNMA BKPH	1
67	C35181	WASHER,.344IDX1.50DX.09 CU BPH	1
68	C35162	NUT, 5/16-18 SQ	1
69	C35129	PULLEY, .906X.305 NYLON	1
70	C35163	PIN, CLEVIS .38 DIA X1.00 LG	1
71	C34908	PIN, HAIR .091 DIA X1.66LG	1
72	C34825	CLEVIS, LIFT CABLE	1
73	C34824	NUT, 1/4-20 REGSQ	1
74	C34826	PIN CLEVIS .312 X .812	1
75	C35164	PIN, COTTER .090/.086X.75LG	1
76	C35165	LIFT COVER-39"	1
77	C35166	SCREW, #10 X.75 HHPLAST	3

STEERING ASSEMBLY

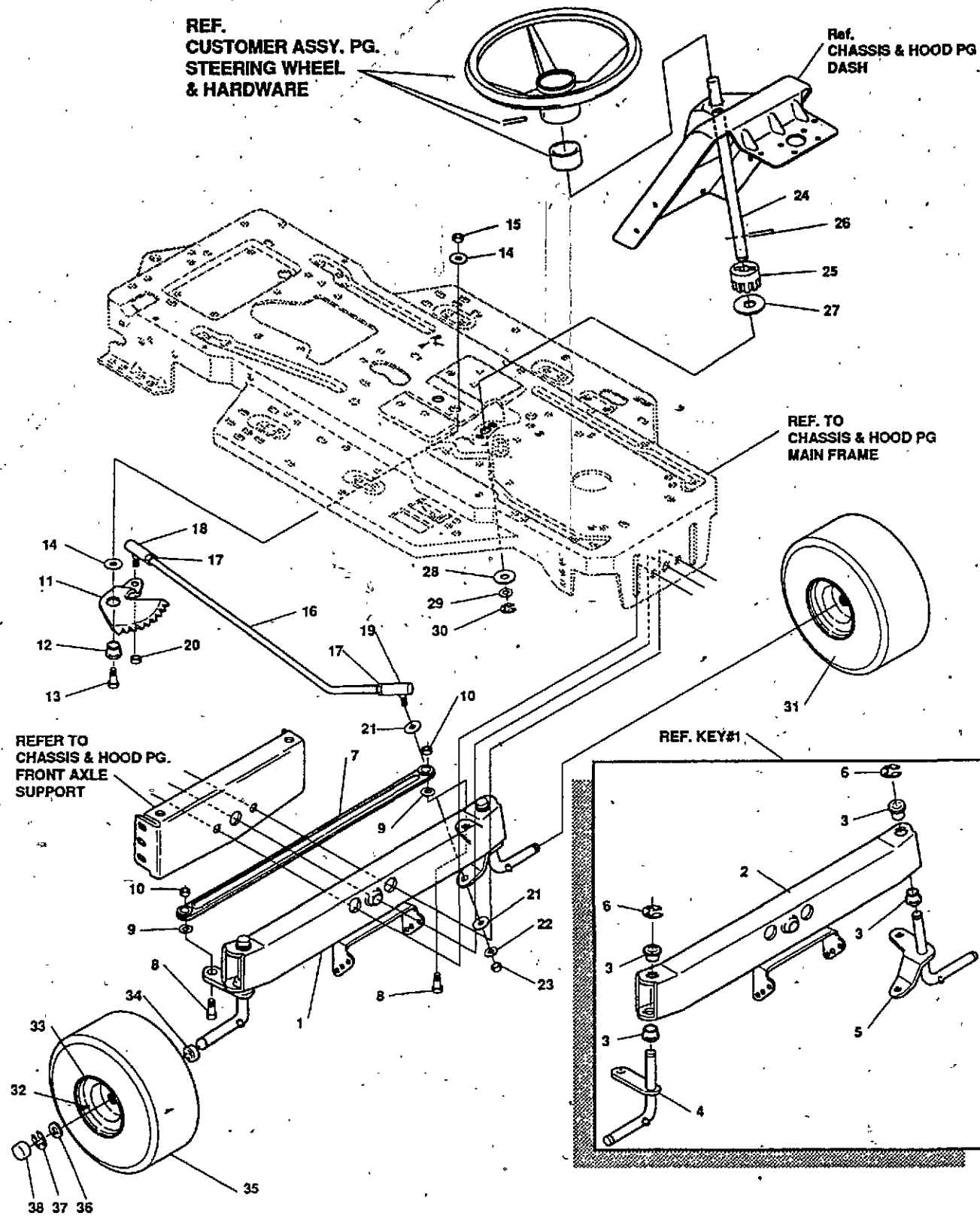

key#	part#	description	qty.
1		ASSY, AXLE FRONT	1
2	C35167	AXLE, FRONT	1
3	C35390	SPINDLE BEARING	4
4	C35391	SPINDLE RH	1
5	C35392	SPINDLE LH	1
6	C34917	RING, RETEX .57X.05TRU5133-75	2
7	C35172	TIE ROD ASSY 19.81LG	1
8	C35173	SCREW, 3/8-16X1.75 HHC	2
9	C34861	WASHER, REGSPTLK.393X.68X.10	2
10	C34814	NUT, 3/8-16 REGHXCTRLK	2
11	C35393	SECTOR, STEERING LF	1
12	C35394	BRNG, FL ECC.510IDX .998ODX .56	1
13	C35395	SCREW, 1/2-13X1.50 HHC	1
14	C35396	WASHER, FLAT .515X1.38X.119	2
15	C35375	NUT, 1/2-13 REGHCTRLK	1
16	C35397	STEERING LINK	1
17	C35182	NUT, 3/8-24 REGHEXJAM	2
18	C35183	BALL JOINT 3/8 TH'D SHORT STUD	1
19	C35398	BALL JOINT 3/8 TH'D LONG STUD	1
20	C35186	NUT, 3/8-24 WDFLHLK	1
21	C34892	WASHER, FLAT .531X1.06X.095	2
22	C34861	WASHER, REGSPTLK.393X.68X.10	1
23	C35174	NUT, 3/8-24 REGHEX	1
24	C35399	SHAFT, STEERING	1
25	C35400	PINION, STEERING	1
26	C35401	PIN, DOWEL .2500 OD+1.75	1
27	C35402	BRNG, FL .752IDX1.061ODX .24	1
28	C35403	WASHER, FORMED1.135X1.53X.12	1
29	C35207	WASHER, FLAT .765X1.25X.042	1
30	C34917	RING, RETEX .57X.05TRU5133-75	1
31		TIRE & RIM, PU 15X6.0X6 SILVER 880	2
32	C34920	VALVE STEM	1
33	C35193	WHEEL W/BRG. W/ZIRK	1
34	C35404	BEARING, FL1.38CD+.753ID	1
35	**	TIRE - FRONT	1
36	C35195	WASHER, FLAT .755X1.31X.075	4
37	C34917	RING, RETEX .57X.05TRU5133-75	2
38	C34918	CAP, 1.500ID X 7/8LG HUB	2

\* Order Individual Parts.

\*\*Order Tires From Local Tire Dealer

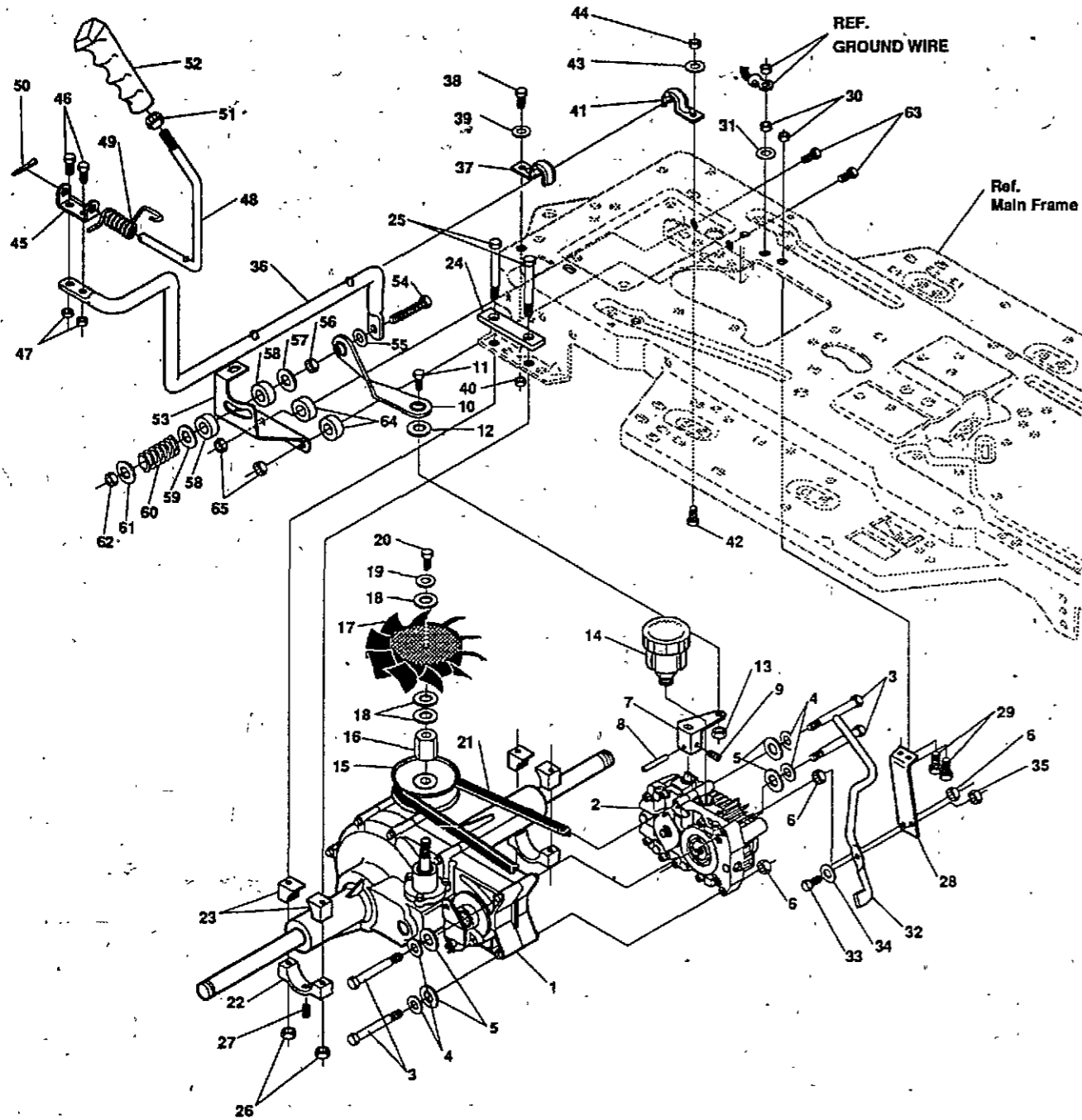

MOTION DRIVE ASSEMBLY

key#	part#	description	qty.
1	C34534**	TRANSAXLE, AGR/FAB HYDRO	1
2	C35405*	HYDROSTATIC PUMP BDU-10S-114	1
3	C35408	SCREW, 5/16-18X4.50 HHC	4
4	C35054	WASHER, HVSP TLK .328X.60X.09	4
5	C34876	WASHER, FLAT .344X.69X.065	4
6	C34798	NUT, 5/16-18 REGHEX CTRLK	3
7	C35407	ARM SPEED CONTROL HYDRO	1
8	C35408	PIN, SPRING.187DIA X .38LG	1
9	C35409	SCREW, 1/4-20X .38 ALHSETCPPT	1
10	C35410	LINK, SHIFT LF HYDRO	1
11	C34860	SCREW, 3/8-16X1.25 HHC	1
12	C34861	WASHER, REGSPLTLK .393X.68X.10	1
13	C34814	NUT, 3/8-16 REGHX CTRLK	1
14	C35411	RESERVIOR, HYDRO	1
15	C35412	PULLEY ASSY HYDRO	1
16	C35413	NUT PULLEY 1/2-20 AND 1/4-20	1
17	C35414	FAN, HYDRO 7.00DIA-10 BLADES	1
18	C35415	WASHER, FLAT .28X1.38X.07	3
19	C35568	WASHER, REGSPTLK.263X.49X.07	1
20	C35243	SCREW, 1/4-20X .62 HHC	1
21	C35416	BELT, V.4L 80.16 HYDRO LF	1
22	C35417	MOUNTING BLOCKS HYDRO	2
23	C35418	MOUNTING BLOCK LH HYDRO	4
24	C35419	PLATE GUIDE	2
25	C35420	SCREW, 5/16-18X2.75 HHC	4
26	C34798	NUT, 5/16-18 REGHEX CTRLK	4
27	C35421	SCREW, 10-32X .25 ALSETCUPT	2
28	C35422	STABILIZER BRACKET, HYDRO	1
29	C34802	SCREW, 5/16-18X1.00 HHC	2
30	C34798	NUT, 5/16-18 REGHEX CTRLK	2
31	C35237	WASHER, REGINLK .320X.61X.03	1
32	C35423	ROD-DUMP VALVE, HYD.ZINC	1
33	C35424	BOLT, .250X .312.HSSH 5/16-18	1
34	C34997	WASHER, .39ID X1.25DX.07 BELLVIL	1
35	C34806	NUT, 1/4-20 REGHEX CTRLK	1
36	C35425	LEVER, SHIFT-LWR, HYDRO	1
37	C35239	CLIP-SHIFT LEVER .62 ROD	1
38	C35006	SCREW, 5/16-18X .75 HHC	1
39	C35240	WASHER, FLAT .391X1.00X.125	1
40	C34798	NUT, 5/16-18 REGHEX CTRLK	1
41	C35239	CLIP-SHIFT LEVER .62 ROD	1
42	C35006	SCREW, 5/16-18 REGHEX CTRLK	1
43	C35240	WASHER, FLAT .391X1.00X.125	1
44	C34798	NUT, 5/16-18 REGHEX CTRLK	1
45	C35242	PIVOT BRKT LEVER	1
46	C35243	SCREW, 1/4-20X .62 HHC	2
47	C34806	NUT, 1/4-20 REGHEX CTRLK	2
48	C35244	LEVER, SHIFT UPPER SF 1/2-13TH	1
49	C35426	SPRING, TORS. .56X.95X.095	1
50	C34890	PIN, COTTER .125 DIA X1.00LG	1
51	C35246	NUT, 1/2-13 HEXJAM	1
52	C35247	HANDLE 1/2-13 MOLDED BLACK	1
53	C35427	QUADRANT, SPEED CONTROL	1
54	C35428	SCREW, 3/8-16X3.00 HHCFT	1
55	C34861	WASHER, REGSPLTLK .393-16X3.00	1
56	C35284	NUT, 3/8-16 HWD FL WHIZ NUT	1
57	C34939	WASHER, FLAT .390X1.25X.119	1
58	C35429	WASHER, FRICTION	2
59	C34939	WASHER, FLAT .390X1.25X.119	1
60	C35430	SPRING	1
61	C34904	WASHER, FLAT .406X.73X.063	1
62	C34814	NUT, 3/8-16 REGHX CTRLK	1
63	C35431	SCREW, 5/16-18X1.25 HHC	2
64	C35432	SPACER .344 X 1.00 X .500	2
65	C34798	NUT, 5/16-18 REGHEX CTRLK	2

\*\*See Transaxle Section For Service Parts

\*See Hydrostatic Pump Section For Service Parts

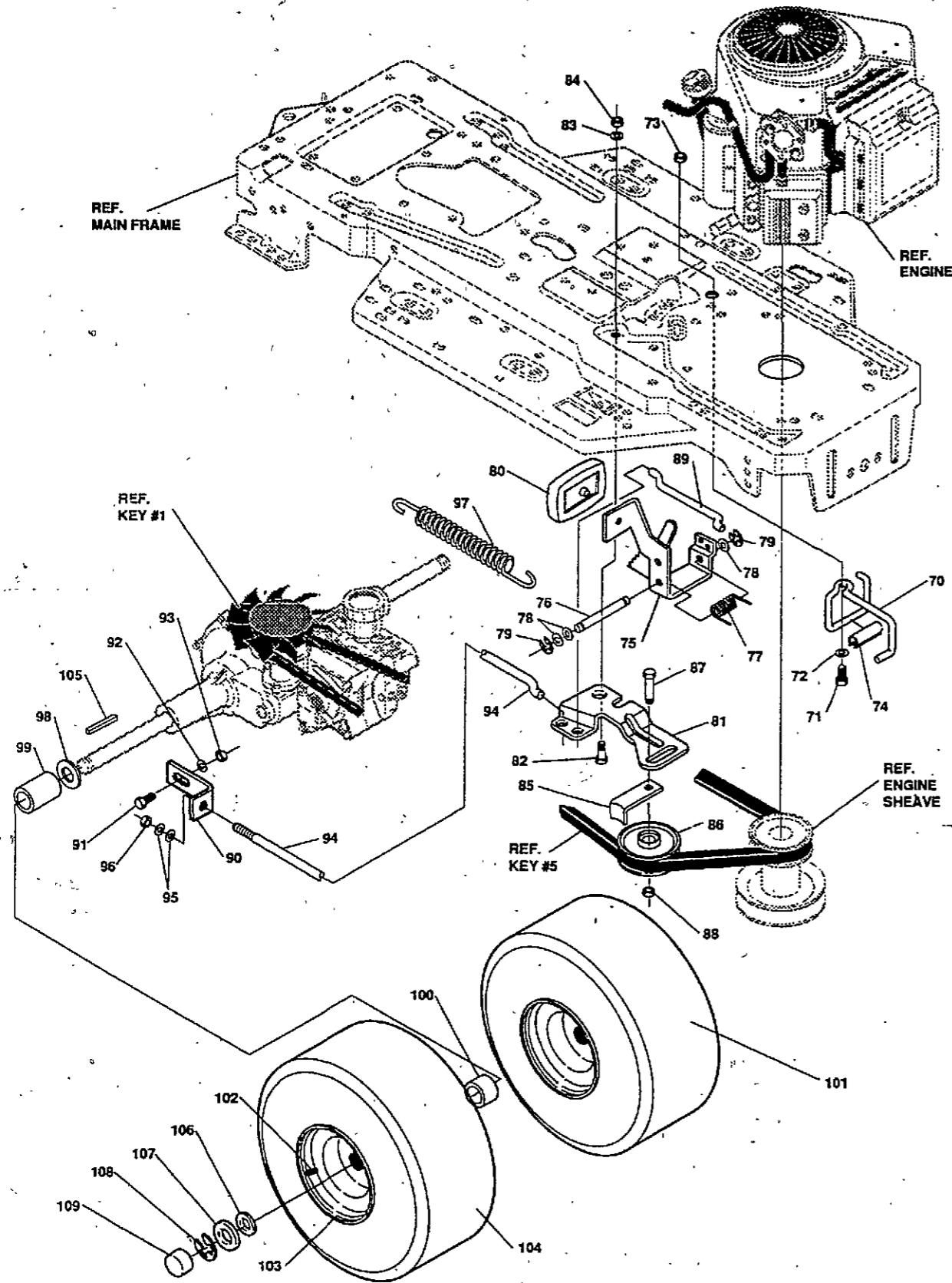

MOTION DRIVE ASSEMBLY

key#	part#	description	qty.
70	C35433	GUIDE-BELT/DRAGLINK	1
71	C35124	SCREW, 5/16-18X1.00 HHC	1
72	C34899	WASHER, FLAT .333X.87X.119	1
73	C34798	NUT, 5/16-18 REGHEXCTRLK	1
74	C35253	PLASTIC EXTRUSION-BELT GUIDE	1
75	C35254	PEDAL ASSY, BRAKE/CLUTCH LF	1
76	C34980	ROD, PIVOT	1
77	C35255	SPRING, BRAKE PEDAL	1
78	C35192	WASHER, FLAT .504X.75X.059	3
79	C34979	RING, RET E .39X.04TRU5133-50	2
80	C35256	PAD, CLUTCH BRAKE W/PRINTING	1
81	C35257	ARM, IDLER TRACTION DR. LF	1
82	C35258	BOLT, .625X.135 HSH 5/16-18	1
83	C34899	WASHER, FLAT .333X.87X.119	1
84	C34798	NUT, 5/16-18 REGHEXCTRLK	1
85	C34903	RETAINER, STRAP BELT	1
86	C34902	PULLEY, IDLER V4L 3.06X.62	1
87	C34905	BOLT, 3/8-16X1.50 CARR	1
88	C34814	NUT, 3/8-16 REGHXCTRLK	1
89	C35259	ROD, CLUTCH	1
90	C34993	BRACKET, BRAKE ROD	1
91	C34816	BOLT, .437X.156 HSH 5/16-18	1
92	C34899	WASHER, FLAT .333X.87X.119	1
93	C34798	NUT, 5/16-18 REGHEXCTRLK	1
94	C35434	ROD, BRAKE LT 920 LF 22.25	1
95	C34876	WASHER, FLAT .344X.69X.065	2
96	C34798	NUT, 5/16-18 REGHEXCTRLK	1
97	C35435	SPRING, CLUTCH .113X.750X8.75	1
98	C34916	WASHER, FLAT .755X1.53X.07	2
99	C35436	SPACER, .75 X 1.25 X 1.32	2
100	C35437	SPACER, SLEEVE	2
101	*	TIRE & RIM 20X10-8 SILVER 880	2
102	C34920	VALVE STEM	1
103	C35438	RIM, WHEEL	1
104	**	TIRE	1
105	C34915	KEY, SQUARE .187SQX2.50LG	2
106	C35195	WASHER, FLAT .755X1.31X.075	4
107	C34916	WASHER, FLAT .755X1.53X.07	2
108	C34917	RING, RETEX .57X.05TRU5133-75	2
109	C34918	CAP, HUB	2

\* Order Individual Parts.

\*\*Order Tires From Local Tire Dealer



ENGINE AND CONTROL ASSEMBLY

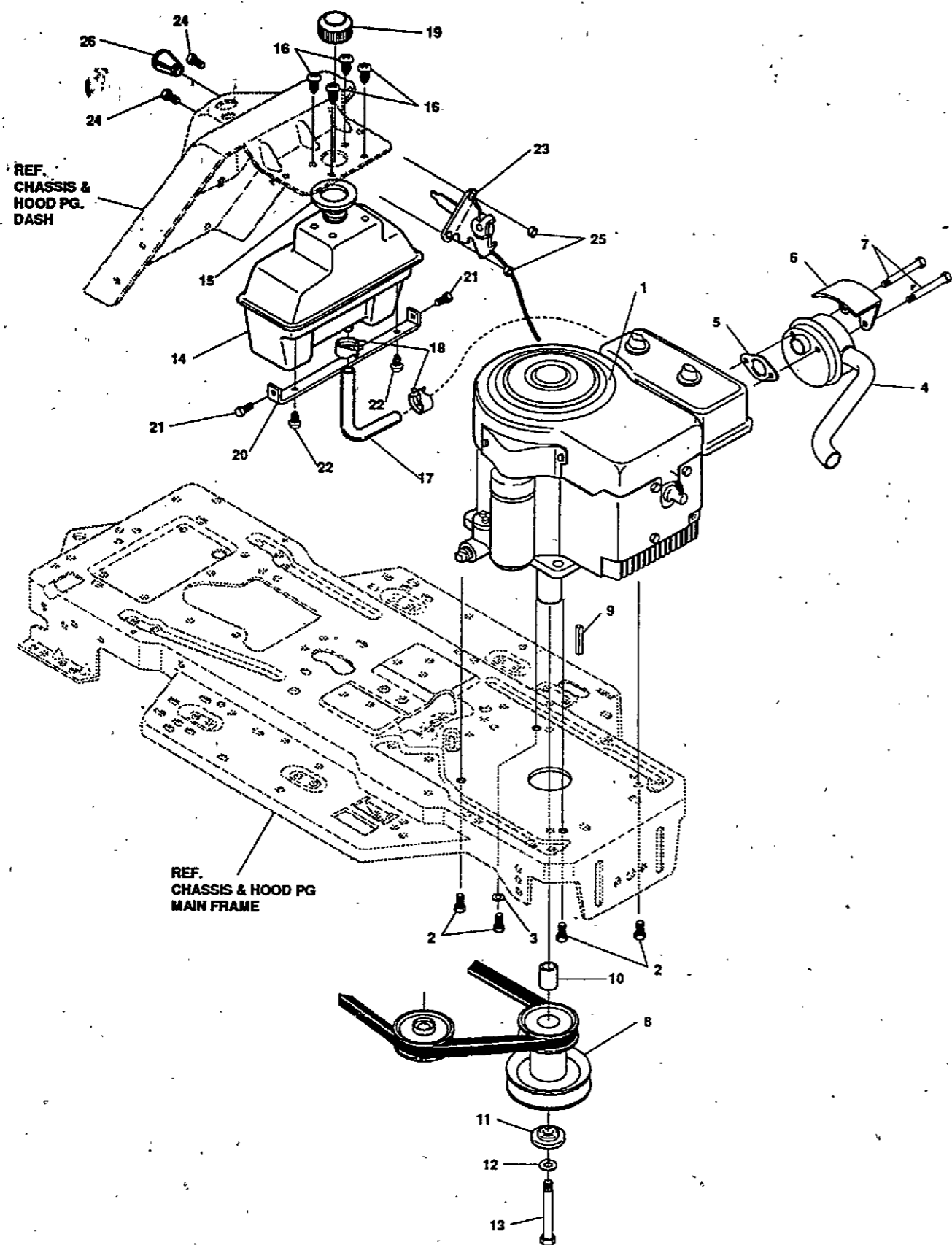

key#	part#	description	qty.
1	C34536*	ENGINE - 12 HP B&S I/C	1
2	C35284	SCREW, 3/8-16X1.25 WAHTAP	4
3	C35265	WASHER, EXLK .384X.69X.04	1
4	C35439	MUFFLER, 10-12 HP W/TUBE FR EXH	1
5	C35440	GASKET, MUFFLER	1
6	C35441	SHIELD, HEAT	1
7	C35442	SCREW, 5/16-18X3.50 HHC	2
8	C35443	PULLEY ASSY, 4.75OFFS 5.5DIA	1
9	C35278	KEY, SQUARE .250SQX5.00LG	1
10	C35279	SPACER, 1.01X1.484 ENGIN PULLEY	1
11	C34925	WASHER, 980IDX1.38ODX.437PILOT	1
12	C34881	WASHER, REGSPTLK.459X.78X.12	1
13	C35280	SCREW, 7/16-20X5.00 HHC	1
14	C35444	TANK, FUEL	1
15	C35445	PAD, FUEL TANK	1
16	C35100	SCREW, 1/4-10X .75PHPNTAP	4
17	C34965	GAS LINE .25ID	13'
18	C34966	CLAMP, FUEL LINE	2
19	C35282	GAS CAP 1-1/2-7 THD	1
20	C35446	BRACKET, FUEL TANK	1
21	C34794	SCREW, 1/4-20X.50 WAHTAP	2
22	C35100	SCREW, 1/4-10X.75 PHPNTAP	2
23	C35447	CONTROL, THROTTLE LF 12HP 20.5	1
24	C35289	SCREW, 10-24X .63PHPNMA	2
25	C35290	NUT, #10-24 HEXKEPS	2
26	C35291	KNOB, ROUND THROTTLE	1

\*See Engine Section

PRE-PAINTED DECK ASSEMBLY

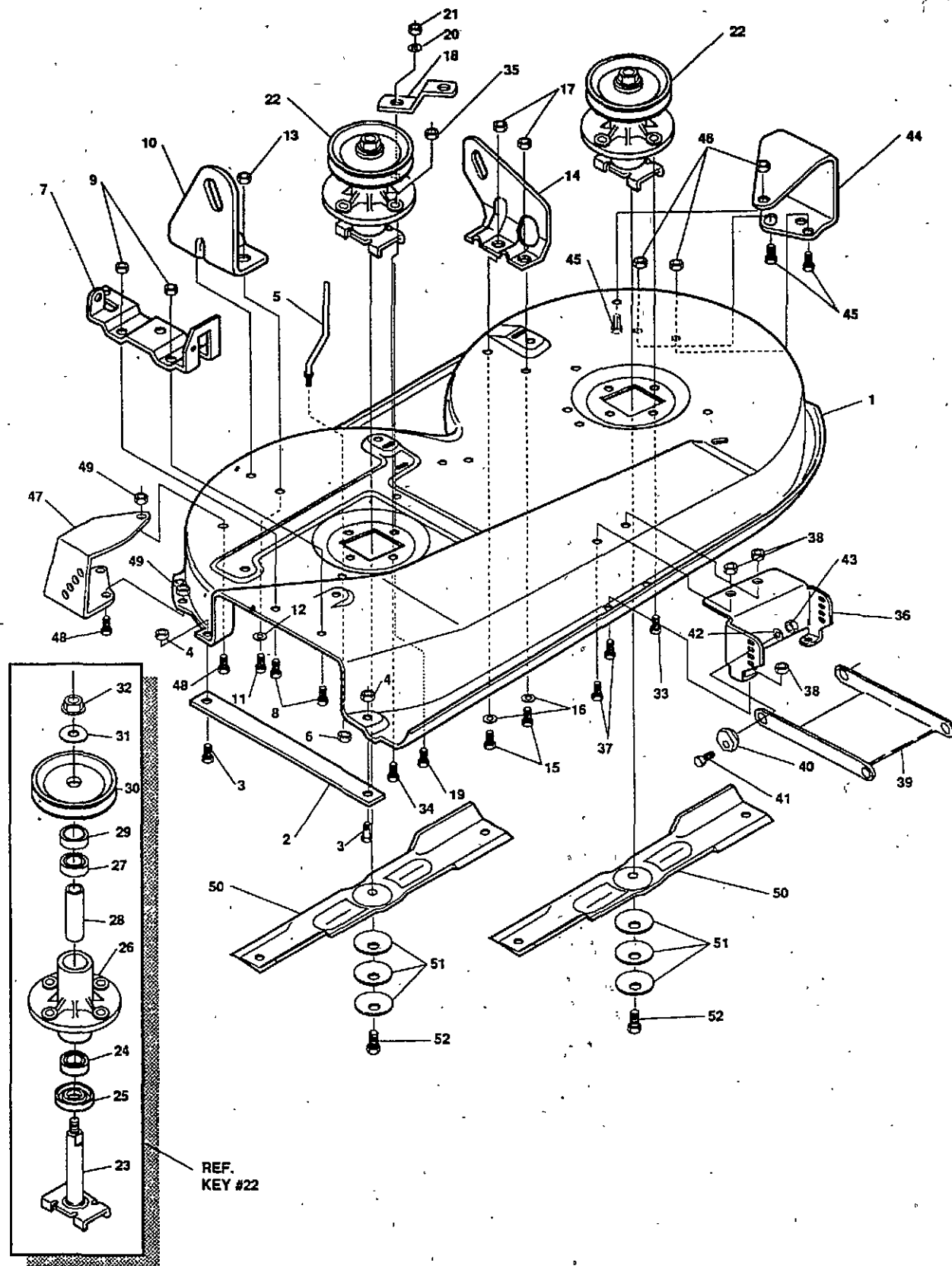

key#	part#	description	qty.
1	C35448	DECK,39"SD MOWER	1
2	C35002	BAR, SKID	1
3	C34895	BOLT, 5/16-18X .75 CARR	2
4	C34798	NUT, 5/16-18 REGHEXCTRLK	2
5	C34999	GUIDE, BELT 5/16-18 THD	1
6	C34798	NUT, 5/16-18 REGHEXCTRLK	1
7	C35003	BRACKET, CHUTE	1
8	C35004	SCREW, 5/16-18X .50 HHC	2
9	C34798	NUT, 5/16-18 REGHEXCTRLK	2
10	C35297	LIFT BRACKET, REAR, RH	1
11	C35006	SCREW, 5/16-18X .75 HHC	2
12	C34876	WASHER, FLAT .344X .69X.065	2
13	C34798	NUT, 5/16-18 REGHEXCTRLK	2
14	C35298	BRACKET, DECK LIFTREAR LH	1
15	C35006	SCREW, 5/16-18X .75 HHC	2
16	C34876	WASHER, FLAT .344X .69X.065	2
17	C34798	NUT, 5/16-18 REGHEXCTRLK	2
18	C35449	BRACKET, IDLER SUPPORT	1
19	C35307	SCREW, 5/16-18X1.38 WATAP	1
20	C34876	WASHER, FLAT .344X .69X.065	1
21	C34798	NUT, 5/16-18 REGHEXCTRLK	1
22	C35300	QUILL ASSY, 36/39/40/43	2
23	C35301	SHAFT/SADDLE 36"	1
24	C34983	BRNG, BALL	1
25	C34985	DUST SHIELD	1
26	C35302	QUILL CASTING	1
27	C34983	BRNG, BALL	1
28	C35303	SPACER, 3.797LGX.669IDX.88OD	1
29	C35304	SPACER, .438LGX.932ODX.672ID	1
30	C34989	PULLEY, 26/36" QUILL	1
31	C34990	SPECIAL WASHER	1
32	C34991	NUT, 7/16-20 WDFLLK	1
33	C34992	SCREW, 5/16-18X .88 WAHTAP	6
34	C35307	SCREW, 5/16-18X1.38 WATAP	1
35	C34798	NUT, 5/16-18 REGHEXCTRLK	1
36	C35450	LIFT SUPPORT FRONT DECK	1
37	C35295	SCREW, 5/16-18X .63 HHC	4
38	C34798	NUT, 5/16-18 REGHEXCTRLK	4
39	C35309	LINK BRACKET, DECK FR	1
40	C35139	ADJUSTING NUT	2
41	C34802	SCREW, 5/16-18X1.00 HHC	2
42	C35311	WASHER, FLAT .328X1.06X.062	2
43	C34798	NUT, 5/16-18 REGHEXCTRLK	2
44	C35451	WHEEL BRKT, LH	1
45	C35295	SCREW, 5/16-18X .63 HHC	3
46	C34798	NUT, 5/16-18 REGHEXCTRLK	3
47	C35452	WHEEL BRKT, RH	1
48	C35295	SCREW, 5/16-18X .63 HHC	3
49	C34798	NUT, 5/16-18 REGHEXCTRLK	3
50	C35453	BLADE, 19.69 HI-LIFT	2
51	C34997	WASHER, .39IDX1.25DX.07 BELLVIL	6
52	C34998	SCREW, 3/8-24X1.00 NYLHHC	2

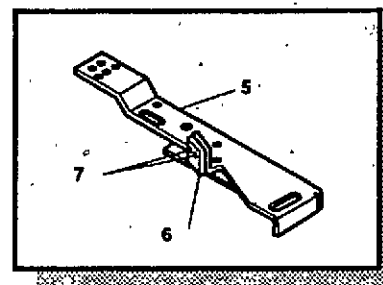

REF KEY #4

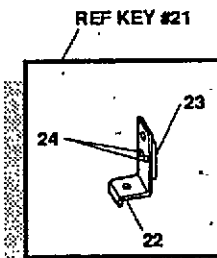

REF KEY #21

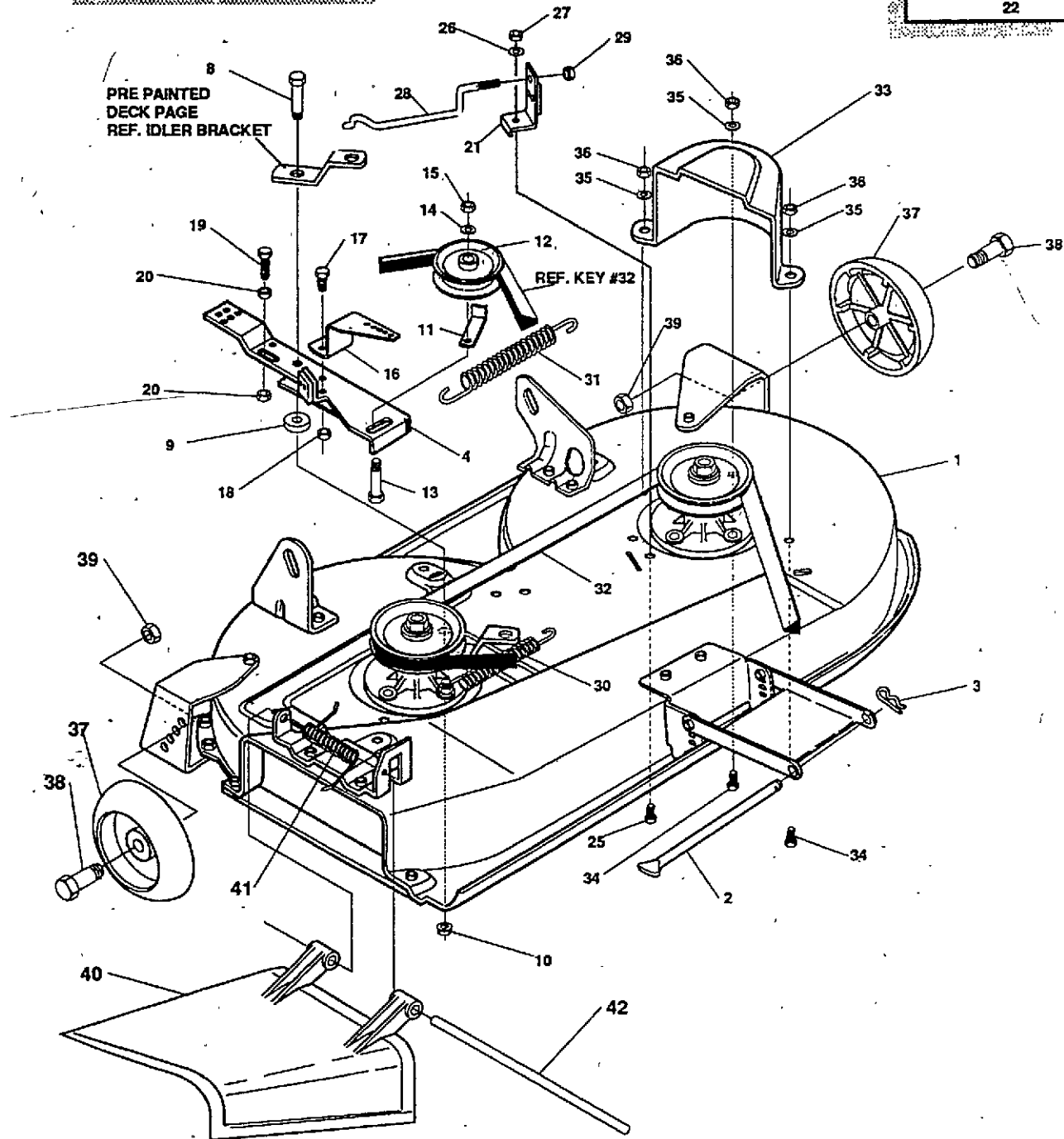

FINAL DECK ASSEMBLY

key#	part#	description	qty.
1		ASSY DECK 39SD 2-DECKWH	1
2	C35316	ROD, DECK HITCH	1
3	C34908	PIN, HAIR .091 DIA X 1.66	1
4	C35454	BRACKET, IDLER ARM/BRAKE	1
5	C35455	IDLER ARM 36,38,39,&45	1
6	C34951	BRAKE PAD - HARD	1
7	C34950	RIVET, TRSET .185DIA X .41	2
8	C35456	BOLT, .50 X 1.88 HSSH 3/8-16	1
9	C35240	WASHER, FLAT .391 X 1.00 X .125	1
10	C35284	NUT, 3/8-16 HWDFL WHIZ NUT	1
11	C35457	BELT RETAINER 2.55 OD	1
12	C35458	PULLEY, IDLER BFF 4.00	1
13	C35327	BOLT, 3/8-16 X 2.00 CARR	1
14	C34861	WASHER, REGSPTLK .393 X .68 X .10	1
15	C35174	NUT, 3/8-16 REGHX	1
16	C35459	BRACKET, EXTENSION IDLER	1
17	C35006	SCREW, 5/16-18 X .75 HHC	1
18	C34798	NUT, 5/16-18 REGHEXCTRLK	1
19	C35460	SCREW, 1/4-20 X 2.00 HHC	1
20	C35024	NUT, 1/4-20 REGHEXKEPS	2
21	C35461	ASSY. BLADE BRAKE	1
22	C35462	BRAKE ARM	1
23	C34951	BRAKE PAD	1
24	C34950	RIVET, TRSET .185DIA X .41	2
25	C34796	SCREW, 5/16-18 X .63 HHC	1
25	C34876	WASHER, FLAT .344 X .69 X .065	1
27	C34798	NUT, 5/16-18 REGHEXCTRLK	1
28	C35463	ROD, BRAKE RELEASE 14.7 39	1
29	C34806	NUT, 1/4-20 REGHEXCTRLK	1
30	C34901	SPRING .071 X .62 X 4.37	1
31	C35464	SPRING, TENSION	1
32	C35465	BELT, V 5L 77.75	1
33	C35466	GUARD, BELT LH	1
34	C35796	SCREW, 5/16-18 X .63 HHC	3
35	C34876	WASHER, FLAT .344 X .69 X .065	3
36	C34798	NUT, 5/16-18 REGHEXCTRLK	3
37	C35371	WHEEL, SD	2
38	C34828	BOLT, .500 X 1.390 HSSH 3/8-16	2
39	C34814	NUT, 3/8-16 REGHEXCTRLK	2
40	C34836	CHUTE-36SD, 39SD	1
41	C34839	SPRING, TORSION	1
42	C34838	PIVOT ROD, CHUTE	1

\* Order Individual Parts.

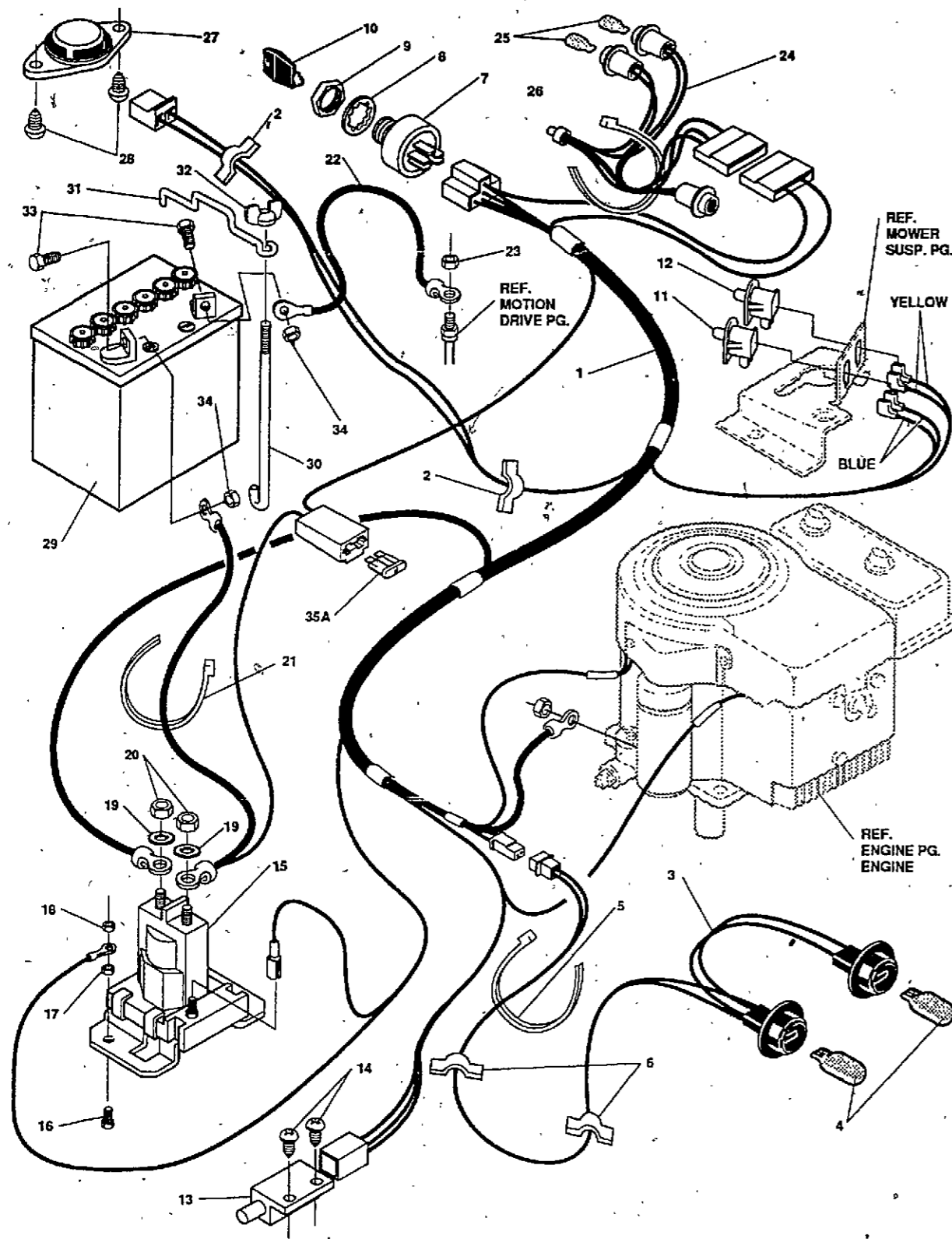

ELECTRICAL ASSEMBLY

key#	part#	description	qty.
1	C35467	WIRE HARNESS LOWES NEUTRAL SAFETY	1
2	C35030	CLIP, 1.380LG .255ID PRESS WIRE	2
3	C35333	ASSY, LIGHT WIRE-1/4 TURN	1
4	C35035	BULB, HEADLAMP	2
5	C35334	TIE, CABLE BLACK NYLON 5.62	1
6	C35030	CLIP, 1.380LG .255ID PRESS WIRE	2
7	C35018	SWITCH, IGNITION & LIGHTS	1
8	C35336	WASHER, REGINTLK.640X1.1X.05	1
9	C35337	NUT, 5/8-32 HXHD IGN SWIT	1
10	C35021	KEY, IGNITION SWITCH	1
11	C35339	SWITCH, SNAPMNT NO .055/.116	1
12	C35017	SWITCH, SNAPMNT NC .055/.166	1
13	C35015	SWITCH, SCR MNT DP NC	1
14	C35016	SCREW, #12 X .50 PHPNHTAP	2
15	C35022	SOLENOID, NEW CLUM	1
16	C35023	SCREW, 1/4-20X .75 HXSEMMA	2
17	C34806	NUT, 1/4-20 REGHEXCTRLK	2
18	C35024	NUT, 1/4-20 REGHEXKEPS	1
19	C34922	WASHER, EXLK .320X.61X.03	2
20	C35640	NUT, 5/16-24 REGHEX	2
21	C35334	TIE, CABLE BLACK NYLON 5.62	1
22	C35033	WIRE, GROUND, 12.5"	1
23	C34833	NUT, 5/16-18 HEXKEPS	1
24	C35468	LIGHT HARNESS 3-IL CHG, MWR, CL	1
25	C35343	BULB, INDICATOR	2
26	C35334	TIE, CABLE BLACK NYLON 5.62	1
27	C35345	SWITCH, SEAT	1
28	C35346	SCREW, 1/4-20X .38PHPNHMA	2
29	C35469	BATTERY, YUASA 12V 7-PLATE	1
30	C35348	ROD, BATTERY	1
31	C35349	ROD, BATTERY, TOP	1
32	C35032	SMALL PLASTIC WING NUT 1/4-20	1
33	C35350	SCREW, 1/4-20X .63 HHC	2
34	C35024	NUT, 1/4-20 REGHEXKEPS	2
35A	**C35036	FUSE, 15 AMP SPADE TYPE	1
35B	**C35351	FUSE, 15 AMP CYLINDRICAL	1

\*\*Cylindrical or Spade type fuse included in wire assembly.

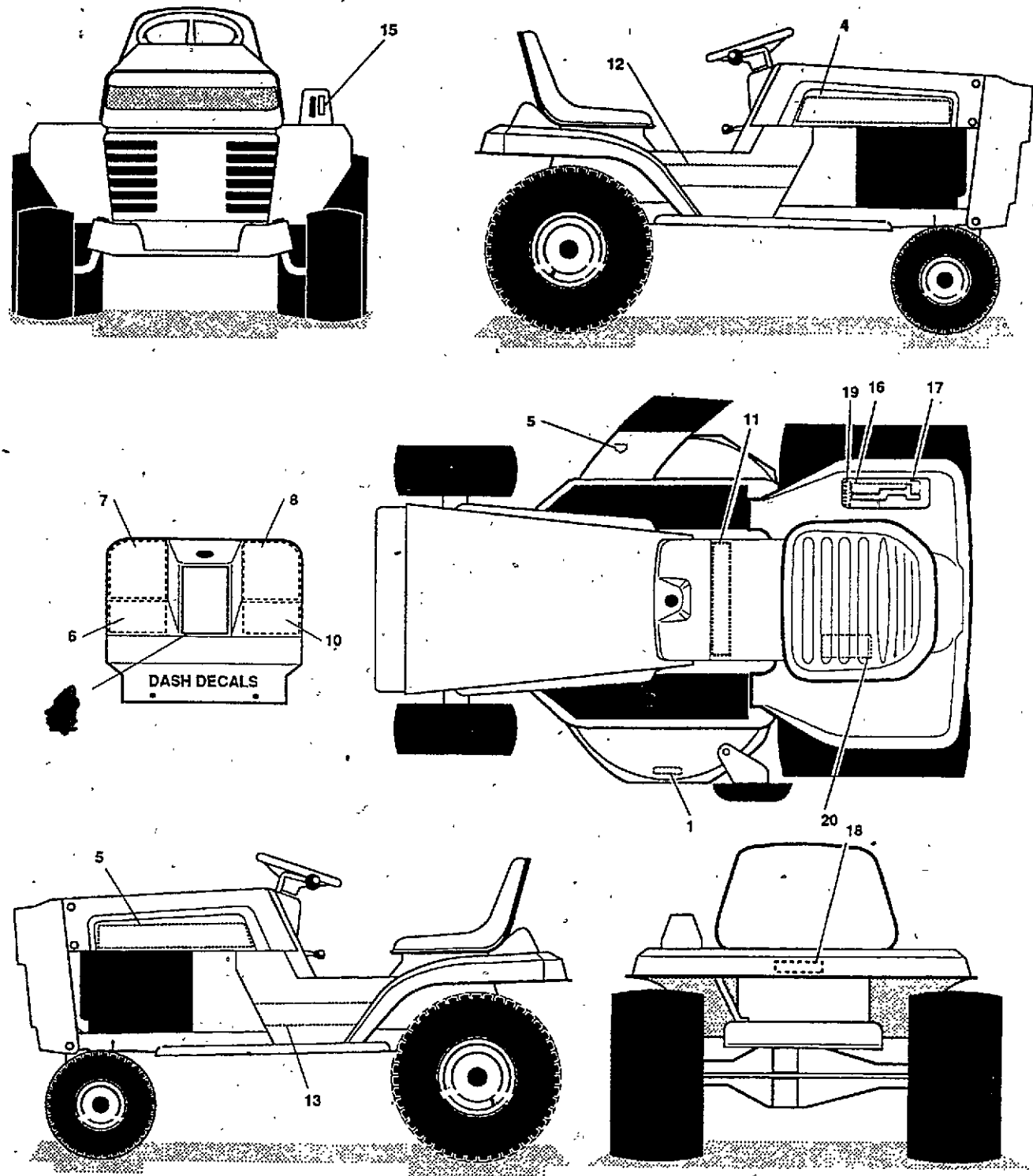

DECALS

key#	part#	description	qty.
1	C35050	DECAL,NO STEP	1
2	C35049	DECAL, CUT-HAND WARNING LABEL	1
3		REFERENCE ONLY	1
4	C35470	DECAL,HOOD SIDE RH 1112H	1
5	C35471	DECAL,HOOD SIDE LH 1112H	1
6	C35354	DECAL,DASH,LH,BLANK,H10/G13	1
7	C35472	DECAL,DASH,LH,THROTTLE H10/G13	1
8	C35473	DECAL, DASH,RH IGNITION W/LTS	1
9	C35357	DECAL,CENTER,ENGLISH INSTRUCT.	1
10	C35474	DECAL,DASH,RH CHARGE/OK I.L.	1
11	C35359	DECAL CAUTION CONSOLE TOP LF	1
12	C35360	DECAL,CONSOLE RH	1
13	C35361	DECAL,CONSOLE LH	1
14		REFERENCE ONLY	1
15	C35362	DECAL, LIFT DECK BLADE HEIGHT	1
16	C35475	DECAL SHIFTER LF HYDRO FORWARD	1
17	C35476	DECAL SHIFT LF HYDRO REVERSE	1
18	C35052	NAMEPLATE, INGERSOLL	1
19	C35477	DECAL, DEPRESS CL/BRAKE HYDRO	1
20	C35478	DECAL, RELIEF VALVE OPERATION	1

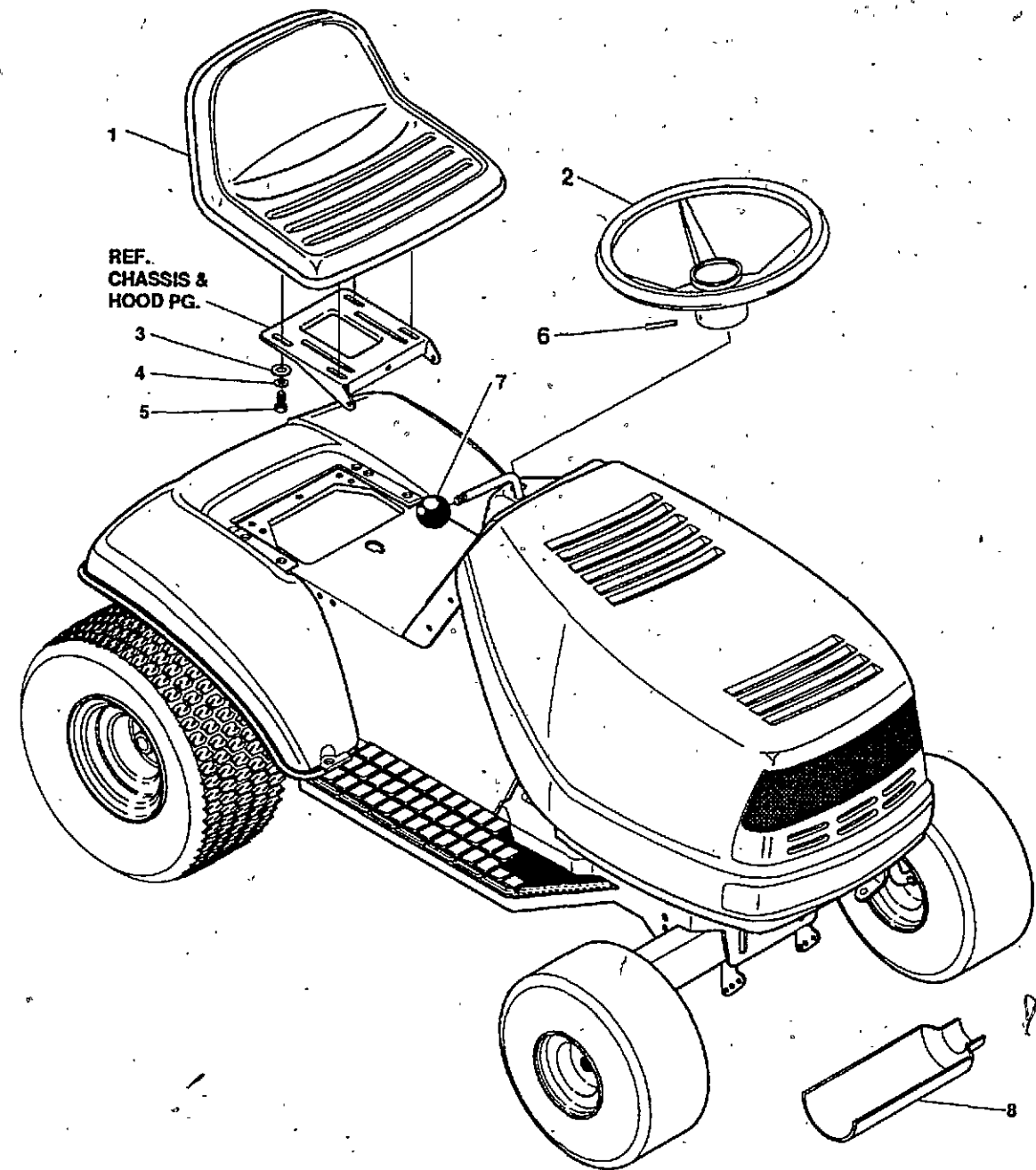

## 39" LAWN TRACTOR MODEL 1112H

## CUSTOMER ASSEMBLY

key#	part#	description	qty
1	C35366	SEAT MV350	1
2	C35479	STEERING WHEEL	1
3	C34876	WASHER,FLAT .344X.69X.065	4
4	C35054	WASHER,HVSP TLK .328X.60X.09	4
5	C34875	SCREW,5/16-18X.75 HHC	4
6	C35368	PIN,SPRING .250DIA X2.00	1
7	C35053	SHIFT KNOB	1
8	C35369	TROUGH,OIL DRAIN	1

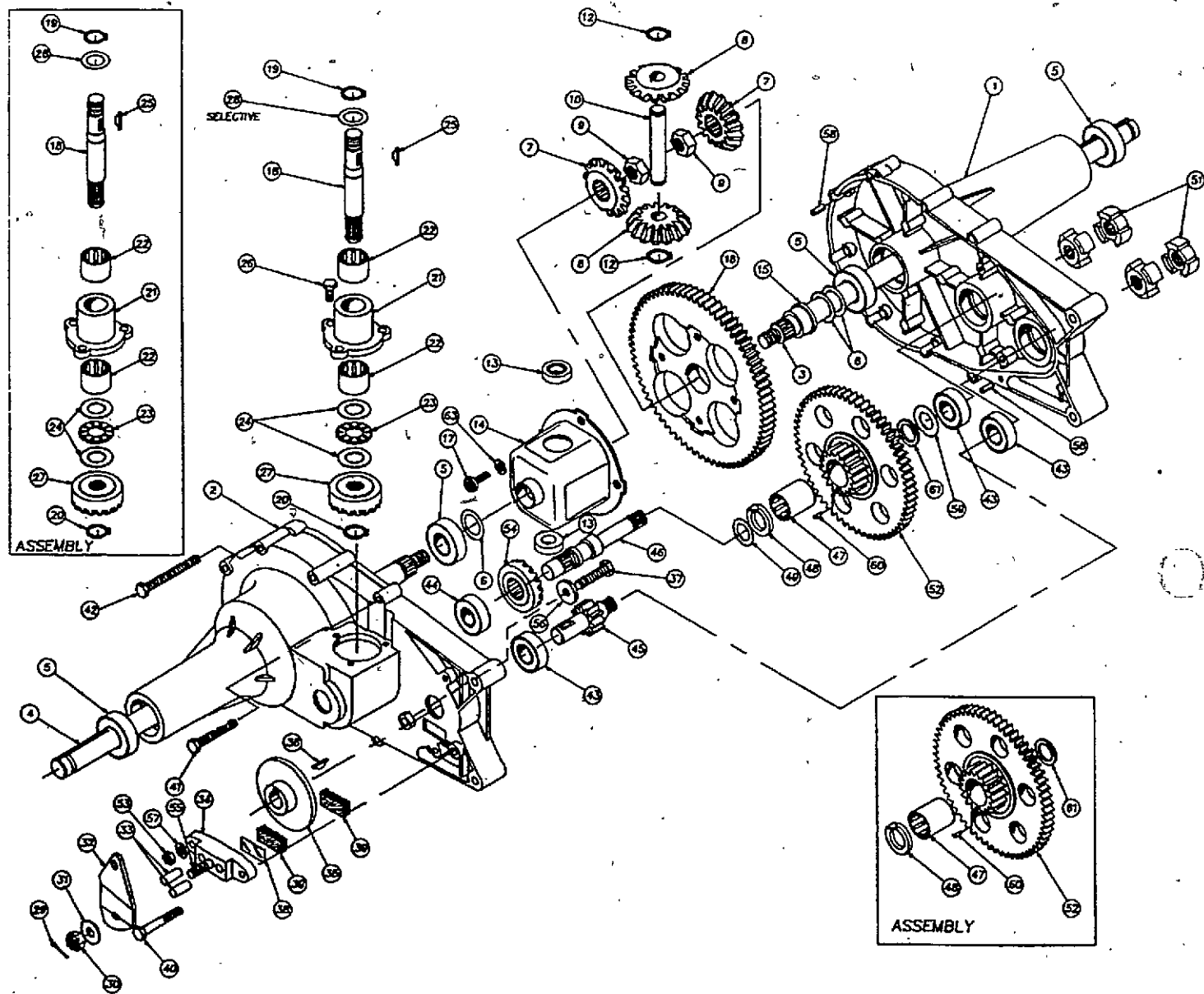

TRANSAXLE

KEY	PART NO.	DESCRIPTION	QTY
0	C34534	TRANSAXLE ASSEMBLY	1
1	C34422	HOUSING - HALF LH	1
2	C34423	HOUSING - HALF RH	1
3	C34424	AXLE - 3/4" LH	1
4	C34425	AXLE - 3/4" RH	1
5	C34426	BEARING - BALL	4
6	C34427	WASHER - FLAT 3/4" X 1-18" X .030"	3
7	C34428	GEAR - NITER	2
8	C34429	GEAR - NITER	2
9	C34430	NUT - 1/2"-20	2
10	C34431	SHAFT - CROSS	1
12	C34432	RING - SNAP	2
13	C34433	BEARING - THRUST	2
14	C34434	HOUSING - DIFFERENTIAL	1
15	C34435	BEARING - FLANGE	1
16	C34436	GEAR - DIFFERENTIAL 72T	1
17	C34437	BOLT - TORX 1/4"-28 X 5/8"	4
18	NSS	SHAFT - INPUT (USE C35497 ASSEMBLY)	1
19	C34439	RING - SNAP	1
20	C34440	RING - RETAINING 7/16" EXT. DIA.	1
21	NSS	HOUSING - INPUT (USE C35497 ASSEMBLY)	1
22	C34441	BEARING - NEEDLE	2
23	C34442	BEARING - THRUST	1
24	C34443	WASHER - FLAT 5/8" X 1-1/8" X .030"	2
25	C34444	KEY - 1/8" X 5/8"	1
26	C34445	SCREW - 1/4"-20 X 3/4"	3
27	C34446	GEAR - INPUT PINION 17T	1
28	C34447	WASHER - FLAT .62" ID X 1" OD X .050"	1
28	C34448	WASHER - FLAT .62" ID X 1.125" OD X .060"	1
28	C34449	WASHER - FLAT .62" ID X 1" OD X .040"	1
29	C34450	PIN - COTTER	1
30	C34451	NUT - CASTLE 5/16"-24	1
31	C34452	WASHER - FLAT .343" ID X .88" OD X .062"	1
32	C34453	ARM - BRAKE ACTUATOR	1
33	C34454	PIN - BRAKE ACTUATING	2
34	C34455	YOKE - BRAKE	1
35	C34456	DISC - BRAKE	1
36	C34457	KEY - 3/16" X 5/8"	1
37	C34458	SCREW - 1/4"-20 X 1.5"	1
38	C34459	PLATE - BRAKE PAD	1
39	C34460	PAD - BRAKE	2
40	C34461	SCREW - 1/4"-20 X 1"	1
41	C34462	SCREW - SELF TAP 1/4"-20 X 2"	4
42	C34463	SCREW - SELF TAP 1/4"-20 X 3"	6
43	C34464	BEARING - BALL	3
44	C34465	BEARING - BALL	1
45	C34466	SHAFT - PINION	1
46	C34467	SHAFT - DRIVE	1
47	C34468	BEARING - NEEDLE	1
48	C34469	BEARING - THRUST 5/8" ID X 1-1/4" OD X 7/64"	1
49	C34447	WASHER - FLAT .62" ID X 1" OD X .050"	1
49	C34449	WASHER - FLAT .62" ID X 1" OD X .040"	1
51	C34470	COUPLING	1
52	NSS	GEAR - REDUCTION (USE C34482 ASSEMBLY)	4
53	C34471	NUT - 1/4"-20	1
54	C34472	GEAR - DRIVE PINION 17T	1
55	C34473	BOLT - SQUARE HEAD	1
56	C34474	WASHER - .265" ID X 15/16" OD X .125"	1
57	C34475	LOCKWASHER - 1/4"	1
58	C34476	PIN - ROLL 3/16" X 1/2"	2
59	C34477	WASHER - FLAT .62" ID X 1" OD X .030"	1
60	C34478	PIN - DOWEL 3/32" X 1/4"	1
61	C34479	SEAL - GREASE, BRONZE	1
63	C34480	LOCKWASHER - 1/4"	4

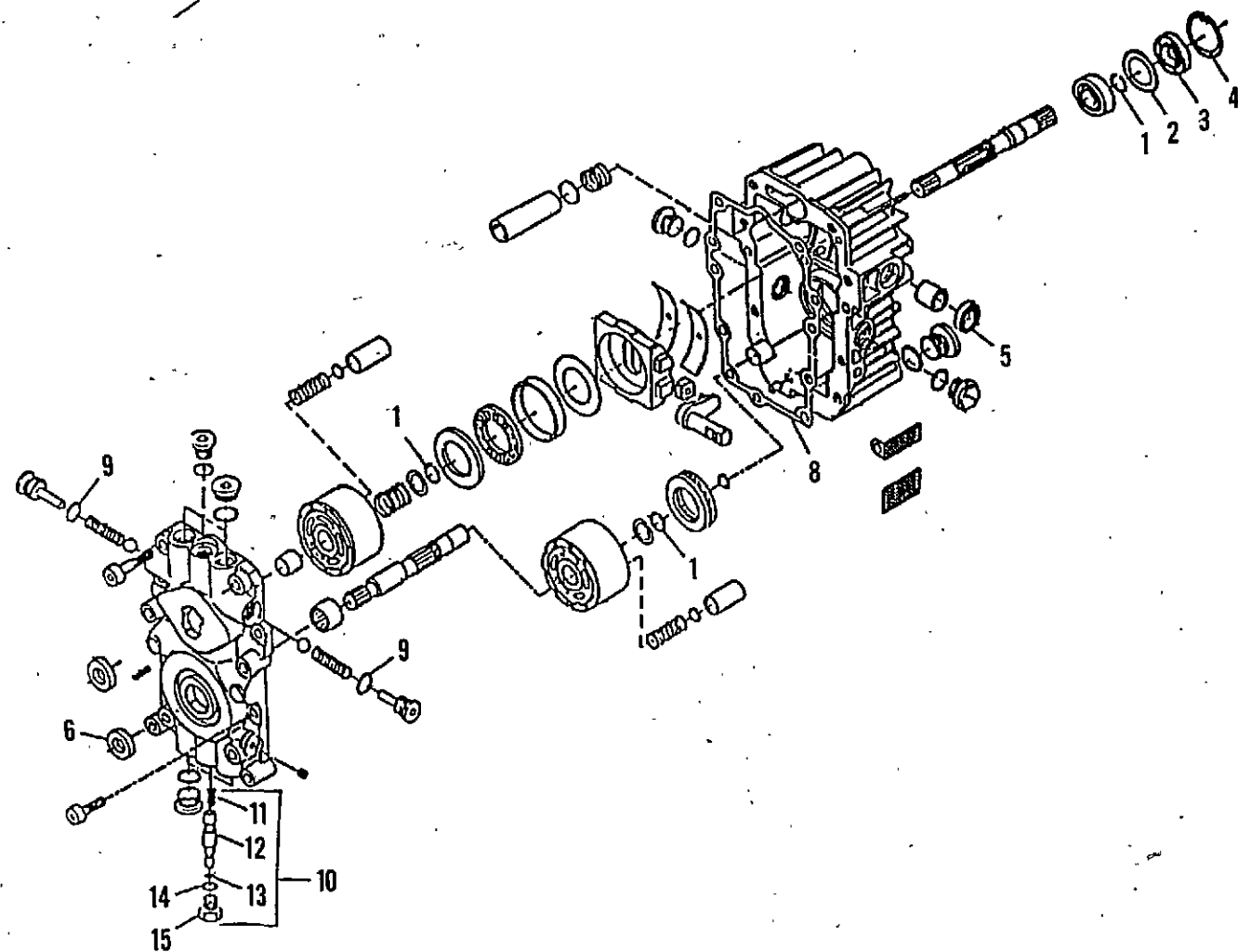

## HYDROSTATIC PUMP

KEY	PART NO.	DESCRIPTION
0	C35405	PUMP - HYDROSTATIC
0	C35546	KIT - SEAL (ALSO INCLUDES KEY NO'S. 13 AND 14)
1	NSS	RING - RETAINING
2	NSS	SPACER
3	NSS	SEAL - LIP
4	NSS	RING - RETAINING
5	NSS	SEAL - LIP
6	NSS	SEAL - LIP
7	NSS	SEAL - LIP
8	NSS	GASKET - HOUSING
9	NSS	"O" RING
10	C35547	KIT - BY-PASS VALVE
11	NSS	SPRING
12	NSS	SPOOL - BY-PASS
13	NSS	"O" RING
14	NSS	"O" RING
15	NSS	PLUG - BY-PASS.



ENGINE BLOCK

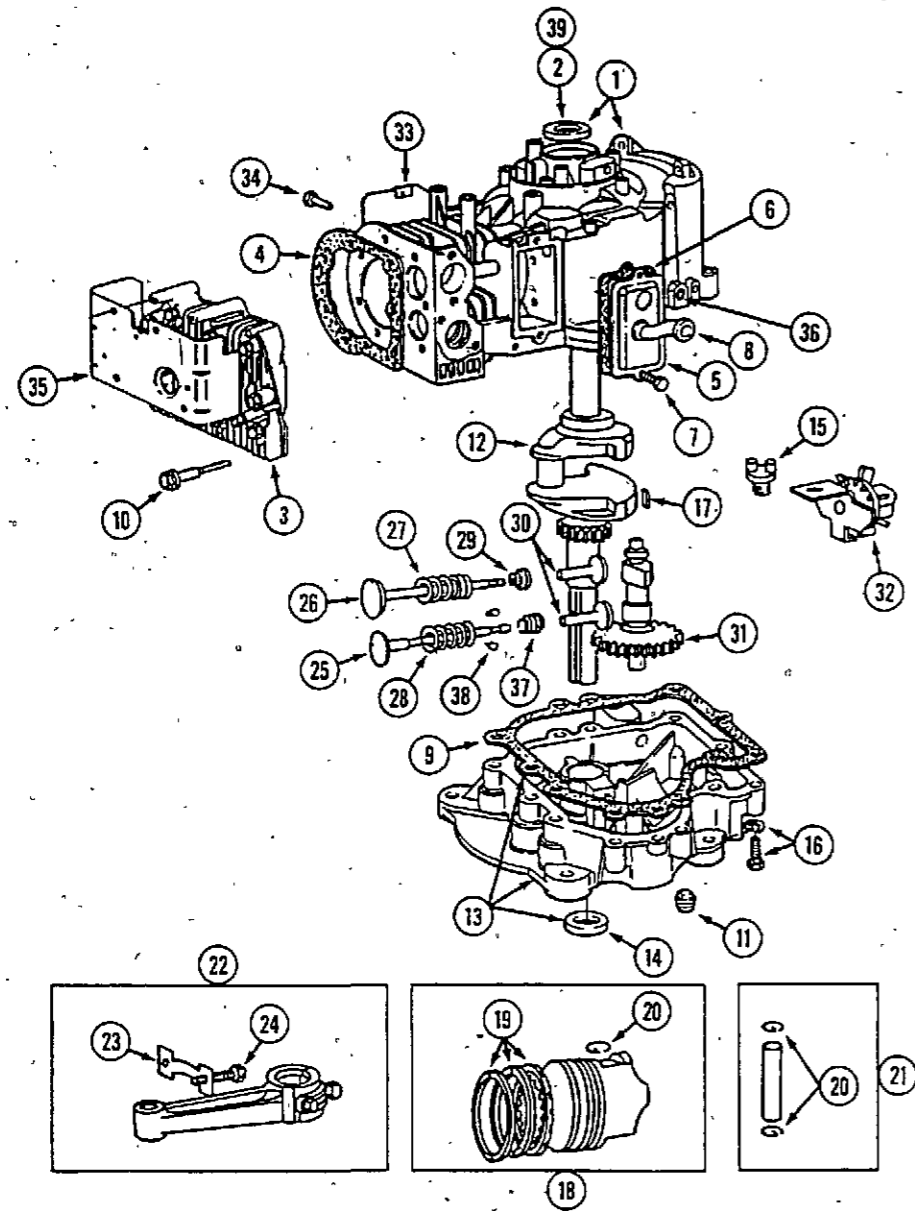

KEY	PART NO.	DESCRIPTION	QTY
0	C30422	GASKET SET - INCLUDES KEY NO. 4,6,9 AND CARB. HTG. GSKT.	1
1	C30843	CYLINDER BLOCK ASSEMBLY - SHORT	1
2	C25709	SEAL - OIL	1
3	C33370	HEAD - CYLINDER	1
4	C30410	GASKET - CYLINDER HEAD	1
5	BR391406	BREATHER ASSEMBLY	1
6	C27350	GASKET - VALVE COVER	1
7	187-1508	SCREW - SEMS NO. 10-24 X 1/2"	2
8	C25712	TUBE - BREATHER	1
9	C30411	GASKET - CRANKCASE COVER 1/64" THICK	1
9	C30412	GASKET - CRANKCASE COVER .005" THICK	1
9	C30413	GASKET - CRANKCASE COVER .009" THICK	1
10	BR93723	SCREW - CYLINDER HEAD 3" LONG	6
11	221-843	PLUG - OIL DRAIN	1
12	C30414	CRANKSHAFT	1
13	C30415	SUMP - OIL (ALSO INCLUDES KEY NO. 9)	1
14	C25718	SEAL - OIL	1
15	BR66768	PLUG - OIL FILLER	1
16	NSS	SCREW - SUMP MOUNTING (USE 113-120 AND 192-20)	6
17	C27236	KEY - FLYWHEEL	1
18	C29826	PISTON ASSEMBLY - STANDARD	1
18	C29827	PISTON ASSEMBLY - .010" OVERSIZE	1
18	C29828	PISTON ASSEMBLY - .020" OVERSIZE	1
18	C29829	PISTON ASSEMBLY - .030" OVERSIZE	1
19	C25725	RING SET - PISTON .010" OVERSIZE	1
19	C25726	RING SET - PISTON .020" OVERSIZE	1
19	C25727	RING SET - PISTON .030" OVERSIZE	1
19	C29830	RING SET - PISTON, STANDARD	1
20	C25728	LOCK - PISTON PIN	2
21	C25729	PIN ASSEMBLY - PISTON, STANDARD	1
21	C25730	PIN ASSEMBLY - PISTON .005" OVERSIZE	1
22	C30416	ROD ASSEMBLY - CONNECTING	1
23	C25732	LOCK - CONNECTING ROD, SCREW	1
24	C25733	SCREW - CONNECTING ROD	2
25	C30417	VALVE - EXHAUST	1
26	C30418	VALVE - INTAKE	1
27	BR65906	SPRING - INTAKE VALVE	1
28	BR26828	SPRING - EXHAUST VALVE	1
29	BR221596	RETAINER - INTAKE VALVE	2
30	C30419	TAPPET - VALVE	2
31	C29833	CAMSHAFT	1
32	C25746	OIL SLINGER - GOVERNOR GEAR AND BRACKET	1
33	C30420	SHIELD - CYLINDER	1
34	NSS	SCREW - SHIELD MOUNTING (USE 163-18 AND 192-18)	1
35	C33377	COVER - CYLINDER HEAD	1
36	C33379	BUSHING - GOVERNOR CRANK (1/4" I.D.)	1
37	BR292260	ROTATOR - EXHAUST VALVE	1
38	BR93630	RETAINER - EXHAUST VALVE	2
39	C29778	BEARING - CRANKSHAFT	1

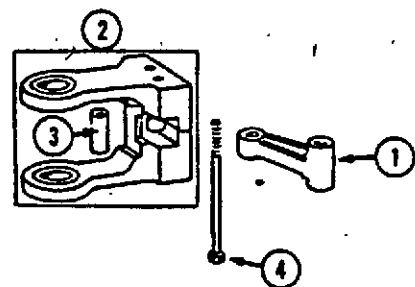
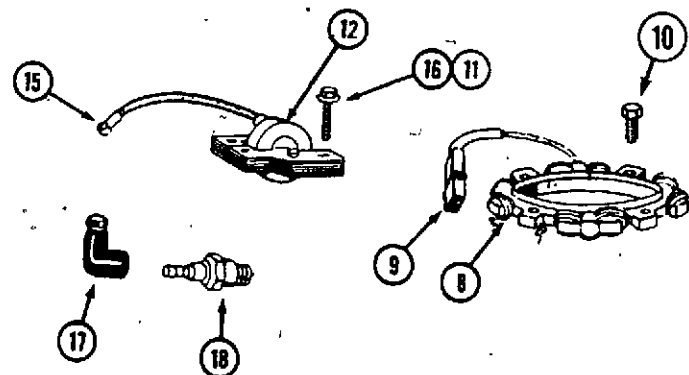
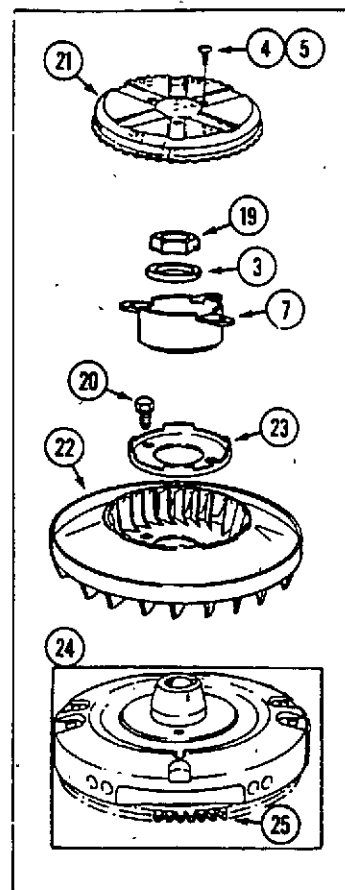
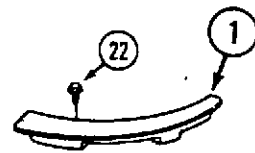
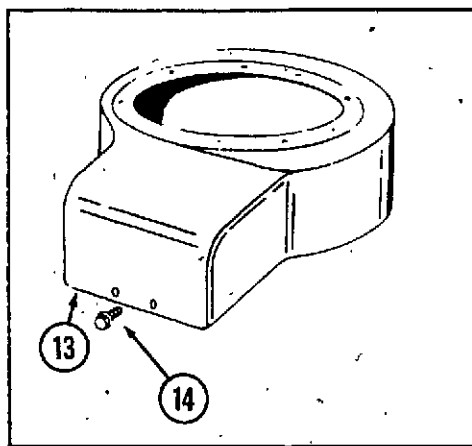

**FLYWHEEL AND STATOR**

KEY	PART NO.	DESCRIPTION	QTY
1	C30446	GUARD - FLYWHEEL	1
3	BR220865	WASHER - SPRING	1
4	182-84	SCREW - NO. 8-32 X 3/8"	4
5	193-25	LOCKWASHER - NO. 8	4
7	BR222561	CUP - SCREEN MOUNTING	1
8	C29867	STATOR - ALTERNATOR	1
9	C29865	DIODE AND CONNECTOR ASSEMBLY	1
10	182-90	SCREW - NO. 8-32 X 1"	4
11	193-25	WASHER - NO. 8	4
12	C33378	ARMATURE ASSEMBLY	1
13	C30437	HOUSING - BLOWER	1
14	C34539	SCREW - MOUNTING	4
15	BR221798	TERMINAL - IGNITION CABLE	1
16	182-549	SCREW - NO. 8-32 X 3/4"	2
17	BR66538	BOOT - SPARK PLUG	1
18	C24329	SPARK PLUG - RESISTER	1
19	BR92284	NUT - FLYWHEEL	1
20	NSS	SCREW - 3/4" LONG (USE 113-102 AND 92-5)	2
21	BR222562	SCREEN - FLYWHEEL	1
22	C30447	FAN - FLYWHEEL	1
23	C30448	RETAINER - FAN	1
24	C33372	FLYWHEEL AND RING GEAR	1
25	BR392134	RING GEAR	1

**COUNTERWEIGHT**

1	C29816	LINK - COUNTERWEIGHT	1
2	C30423	COUNTERWEIGHT ASSEMBLY	1
3	C29818	PIN - COUNTERWEIGHT	1
4	C29835	SCREW - COUNTERWEIGHT	1

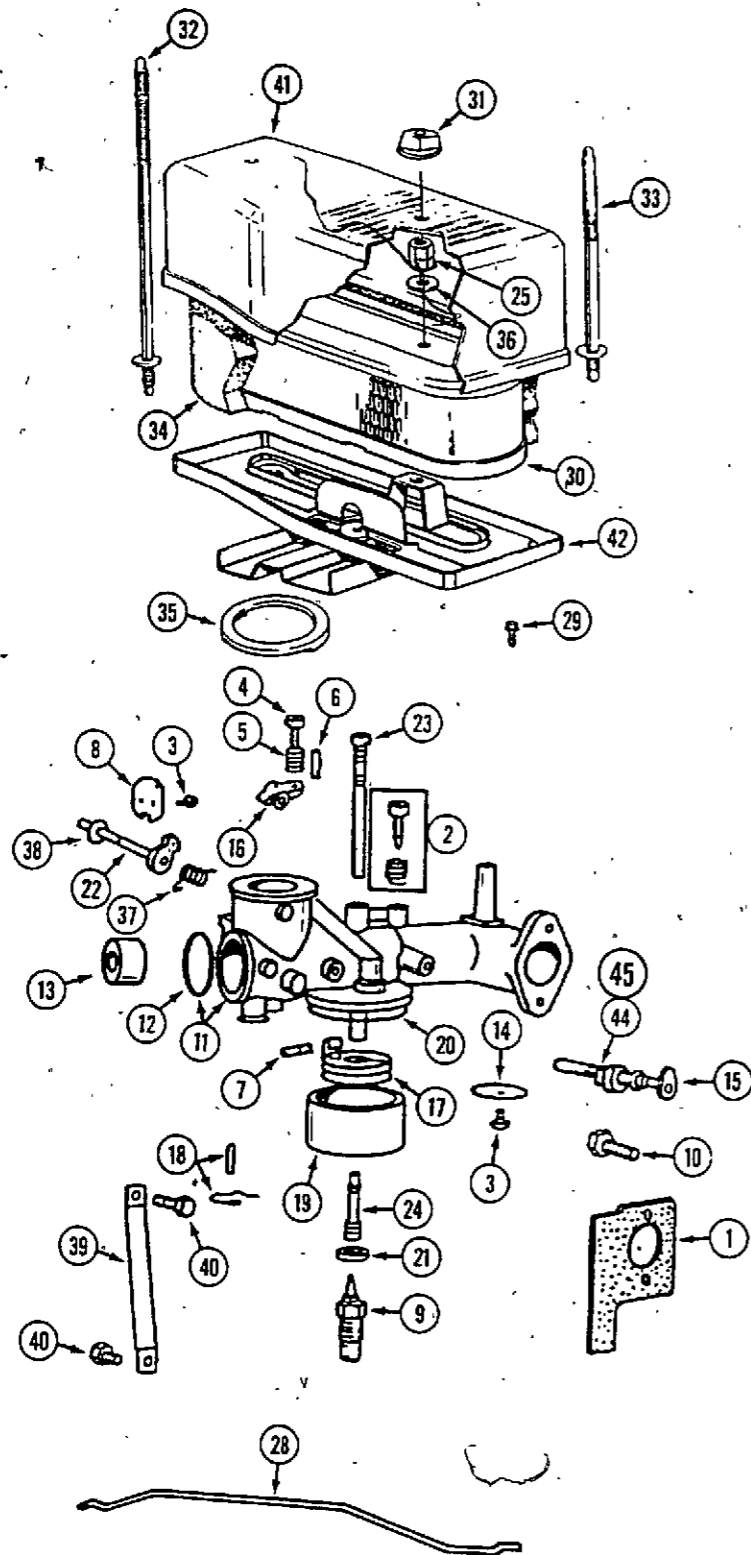

## CARBURETOR

KEY	PART NO.	DESCRIPTION	QTY
0	C27255	KIT - CARB. OVERHAUL (INCLUDES 2,7,9,12,18,20,21,23,24)	1
0	C30424	CARBURETOR	1
0	C31978	FILTER - FUEL	1
1	C25738	GASKET - CARBURETOR MOUNTING	1
2	BR292681	VALVE ASSEMBLY - CARBURETOR IDLE	1
3	BR93499	SCREW - THROTTLE AND CHOKE MOUNTING	2
4	182-87	SCREW - MACHINE, NO. 8-32 X 5/8"	1
5	BR26157	SPRING - THROTTLE ADJUSTMENT	5
6	138-251	PIN - THROTTLE STOP	6
7	BR230896	PIN - FLOAT HINGE	1
8	BR222010	VALVE - CHOKE	1
9	C29779	VALVE - NEEDLE	1
10	BR93357	SCREW - CARBURETOR MOUNTING	2
11	C30425	BODY ASSEMBLY - CARBURETOR	1
12	41-24	PLUG - WELCH	1
13	C25742	VENTURI - CARBURETOR	1
14	C27240	VALVE - THROTTLE	1
15	C30426	SHAFT AND LEVER - THROTTLE	1
16	BR211712	STOP - THROTTLE	1
17	BR299707	FLOAT - CARBURETOR	1
18	C27254	VALVE - FUEL INLET	1
19	BR221995	BOWL - FLOAT	1
20	BR270511	GASKET - FLOAT BOWL	1
21	BR222014	WASHER - FLOAT BOWL	1
22	BR390684	SHAFT AND LEVER - CHOKE	1
23	BR299740	NOZZLE - CARBURETOR	1
24	C29780	SCREW - NOZZLE	1
25	C33344	NUT - AIR CLEANER	1
28	C27244	LINK - CHOKE	1
29	177-97	SCREW - SEMS	1
30	C30428	ELEMENT - AIR CLEANER	1
31	C29854	KNOB - COVER	2
32	C30429	STUD - AIR CLEANER	1
33	C30430	STUD - AIR CLEANER	1
34	C30435	PRECLEANER - ELEMENT	1
35	C25760	GASKET - AIR CLEANER	1
36	C30431	WASHER - AIR CLEANER	1
37	BR261116	SPRING - CHOKE RETURN	1
38	BR270382	WASHER - CHOKE SHAFT	1
39	C25764	BRACKET - CARBURETOR MOUNTING	1
40	187-1510	SCREW	2
41	C30432	COVER - AIR CLEANER	1
42	C30433	BASE - AIR CLEANER	1
44	C30405	SEAL - THROTTLE SHAFT	1
45	C33322	SEAL - FOAM	1

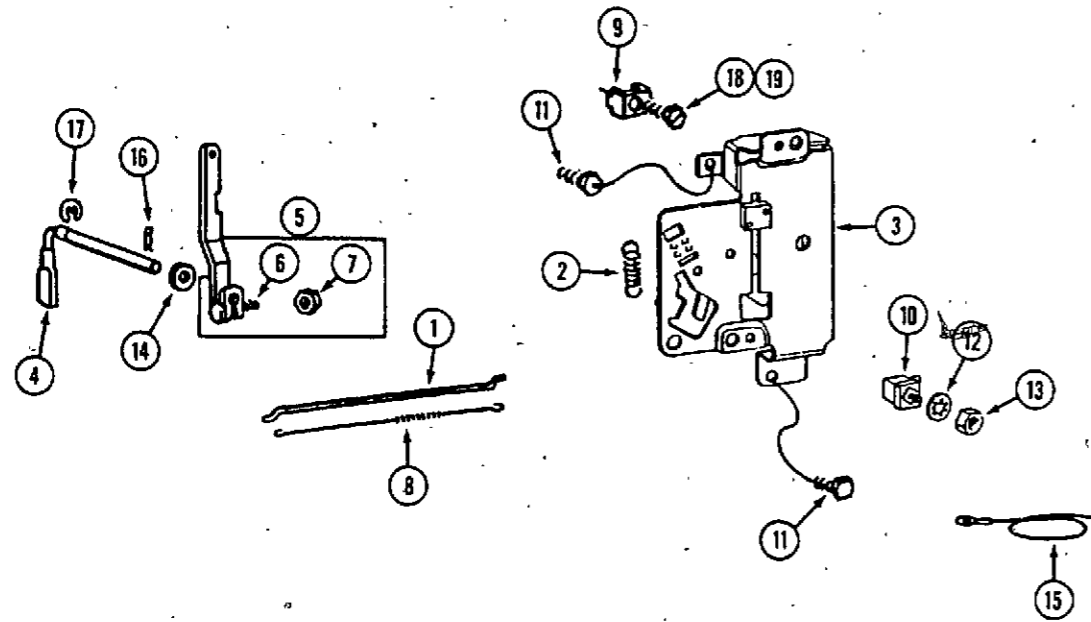

## 39" LAWN TRACTOR MODEL 1112H

## GOVERNOR

KEY	PART NO.	DESCRIPTION	QTY
1	C33374	LINK - GOVERNOR	1
2	C34538	SPRING - GOVERNOR	1
3	C33375	BRACKET - GOVERNOR	1
4	BR231058	CRANK - GOVERNOR	1
5	C33320	LEVER ASSEMBLY	1
6	11-312	BOLT - LEVER	1
7	129-7	NUT - NO. 10-24	1
8	BR260584	SPRING - GOVERNOR LINK	1
9	BR221535	CLAMP - CASING	1
10	C29794	INSULATOR ASSEMBLY	1
11	187-1510	SCREW - MOUNTING, NO. 10-32 X 3/8" SELF TAP	1
12	193-25	LOCKWASHER - NO. 8	2
13	129-6	NUT - NO. 8-32	2
14	BR222450	WASHER - GOVERNOR CRANK	1
15	C29796	WIRE - GROUND	1
16	136-103	PIN - COTTER HAIR PIN	1
17	C28643	RETAINER - "E" RING	1
18	163-4	SCREW - NO. 10-32 X 5/8"	1
19	192-3	WASHER	1

## OIL FILLER

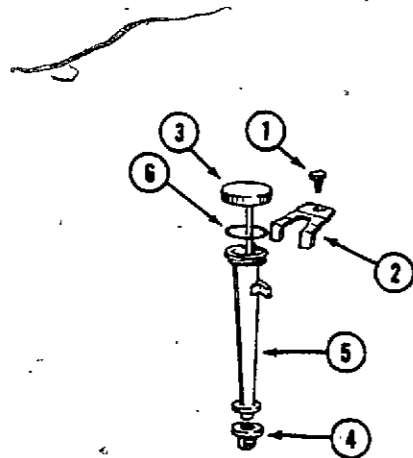

KEY	PART NO.	DESCRIPTION	QTY
1	187-1037	SCREW - CLAMP MOUNTING	1
2	C34540	CLAMP - OIL FILLER TUBE	1
3	C34541	DIPSTICK - OIL	1
4	BR68838	SEAL - FILLER TUBE	1
5	C34542	TUBE - OIL FILLER	1
6	BR270920	SEAL - FILLER CAP	1

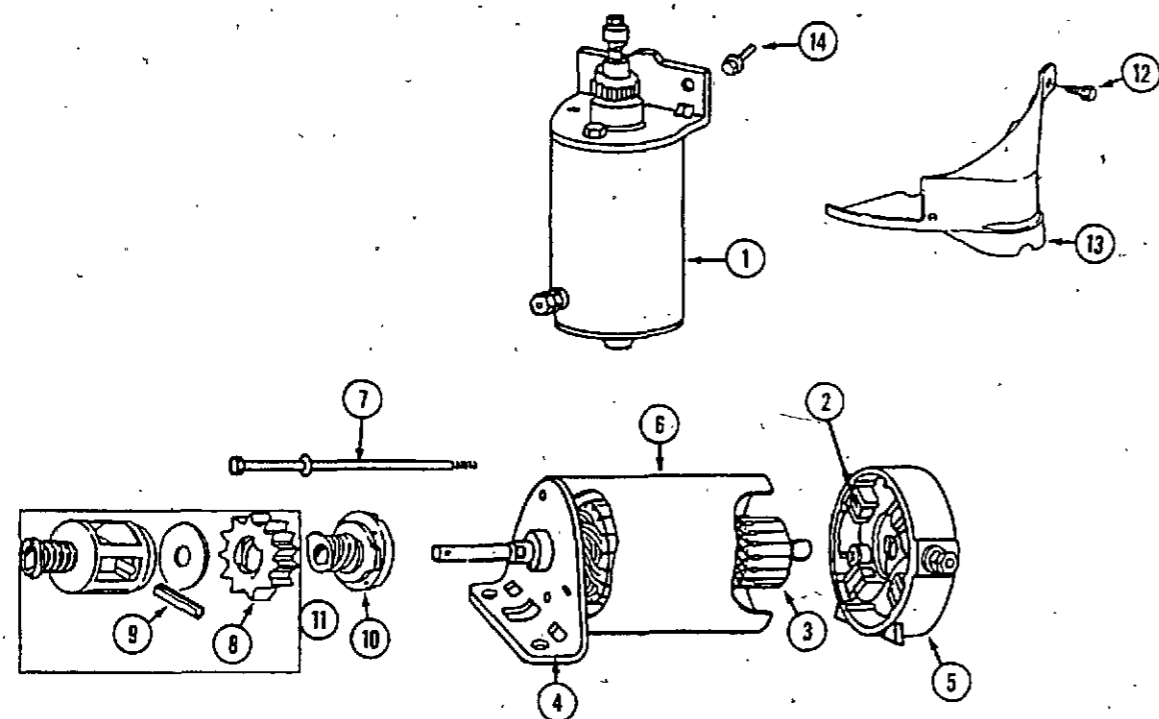

## STARTER

KEY	PART NO.	DESCRIPTION	QTY
1	C30438	MOTOR - STARTER, 12 VOLT	1
2	C27259	BRUSH ASSEMBLY	1
3	C30442	ARMATURE - STARTER	1
4	C30444	END CAP - DRIVE END	1
5	C27258	END CAP - COMMUTATOR END	1
6	C30445	HOUSING - STARTER	1
7	C30439	BOLT - THRU (INCLUDES WASHER)	2
8	C27422	GEAR - STARTER	1
9	138-2032	PIN - ROLL	1
10	C30406	CLUTCH - DRIVE	1
11	C30441	KIT - DRIVE RETAINER	1
12	187-1328	SCREW - NO. 8-18 X 3/8"	2
13	C30443	COVER AND SHIELD - STARTER	1
14	NSS	SCREW - MOUNTING (USE 113-102 AND 92-5)	2

PART NO.	PAGE NO.	REF. NO.	PART NO.	PAGE NO.	REF. NO.
BR 26157	37	5	C29796	39	15
BR 26828	33	28	C29816	35	1
BR 65906	33	27	C29818	35	3
BR 66538	35	17	C29826	33	18
BR 66768	33	15	C29827	33	18
BR 68838	39	4	C29828	33	18
BR 92284	35	19	C29829	33	18
BR 93357	37	10	C29830	33	19
BR 93499	37	3	C29833	33	31
BR 93630	33	38	C29835	35	4
BR 93723	33	10	C29854	37	31
BR211712	37	16	C29865	35	9
BR220865	35	3	C29867	35	8
BR221535	39	9	C30405	37	44
BR221596	33	29	C30406	41	10
BR221798	35	15	C30410	33	4
BR221995	37	19	C30411	33	9
BR222010	37	8	C30412	33	9
BR222014	37	21	C30413	33	9
BR222450	39	14	C30414	33	12
BR222561	35	7	C30415	33	13
BR222562	35	21	C30416	33	22
BR230896	37	7	C30417	33	25
BR231058	39	4	C30418	33	26
BR260584	39	8	C30419	33	30
BR261116	37	37	C30420	33	33
BR270382	37	38	C30422	33	
BR270511	37	20	C30423	35	2
BR270920	39	6	C30424	37	
BR292260	33	37	C30425	37	11
BR292681	37	2	C30426	37	15
BR299707	37	17	C30428	37	30
BR299740	37	23	C30429	37	32
BR390684	37	22	C30430	37	33
BR391406	33	5	C30431	37	36
BR392134	35	25	C30432	37	41
C24329	35	18	C30433	37	42
C25421	13	27	C30435	37	34
C25709	33	2	C30437	35	13
C25712	33	8	C30438	41	1
C25718	33	14	C30439	41	7
C25725	33	19	C30441	41	11
C25726	33	19	C30442	41	3
C25727	33	19	C30443	41	13
C25728	33	20	C30444	41	4
C25729	33	21	C30445	41	6
C25730	33	21	C30446	35	1
C25732	33	23	C30447	35	22
C25733	33	24	C30448	35	23
C25738	37	1	C30843	33	1
C25742	37	13	C31978	37	
C25746	33	32	C33320	39	5
C25760	37	35	C33322	37	45
C25764	37	39	C33344	37	25
C27236	33	17	C33370	33	3
C27240	37	14	C33372	35	24
C27244	37	28	C33374	39	1
C27254	37	18	C33375	39	3
C27255	37		C33377	33	35
C27258	41	5	C33378	35	12
C27259	41	2	C33379	33	36
C27350	33	6	C34156	9	62
C27422	41	8	C34381	5	49
C28643	39	17	C34422	29	1
C29778	33	39	C34423	29	2
C29779	37	9	C34424	29	3
C29780	37	24	C34425	29	4
C29794	39	10	C34426	29	5

PART NO.	PAGE NO.	REF. NO.
C34427	29	6
C34428	29	7
C34429	29	8
C34431	29	9
C34432	29	10
C34433	29	11
C34434	29	12
C34435	29	13
C34436	29	14
C34437	29	15
C34439	29	16
C34440	29	17
C34441	29	19
C34442	29	20
C34443	29	22
C34444	29	23
C34445	29	24
C34446	29	25
C34447	29	26
C34448	29	27
C34449	29	28
C34450	29	28
C34451	29	49
C34452	29	29
C34453	29	30
C34454	29	31
C34455	29	32
C34456	29	33
C34457	29	34
C34458	29	35
C34459	29	36
C34460	29	37
C34461	29	38
C34462	29	39
C34463	29	40
C34464	29	41
C34465	29	42
C34466	29	43
C34467	29	44
C34468	29	45
C34469	29	46
C34470	29	47
C34471	29	48
C34472	29	51
C34473	29	53
C34474	29	54
C34475	29	55
C34476	29	56
C34477	29	57
C34478	29	58
C34479	29	59
C34480	29	60
C34481	29	61
C34482	29	63
C34534	13	1
C34534	29	1
C34536	17	1
C34538	39	2
C34539	35	14
C34540	39	2
C34541	39	2
C34542	39	3
C34794	5	25
C34794	5	27
C34794	7	75
C34794	17	21
C34796	7	68

PART NO.	PAGE NO.	REF. NO.	PART NO.	PAGE NO.	REF. NO.	PART NO.	PAGE NO.	REF. NO.
C34796	21	25	C34834	5	31	C34985	19	25
C34798	5	11	C34836	21	40	C34989	19	30
C34798	5	18	C34838	21	42	C34990	19	31
C34798	5	46	C34839	21	41	C34991	19	32
C34798	7	67	C34848	5	24	C34992	19	33
C34798	7	69	C34857	9	29	C34993	15	90
C34798	7	78	C34860	13	11	C34997	5	15
C34798	9	4	C34861	11	9	C34997	13	34
C34798	9	25	C34861	11	22	C34997	19	51
C34798	9	30	C34861	13	12	C34998	19	52
C34798	9	33	C34861	13	55	C34999	19	5
C34798	9	37	C34861	21	14	C35002	19	2
C34798	9	39	C34875	27	5	C35003	19	7
C34798	9	42	C34876	9	3	C35004	19	8
C34798	13	6	C34876	13	5	C35006	9	32
C34798	13	26	C34876	15	95	C35006	9	41
C34798	13	30	C34876	19	12	C35006	13	38
C34798	13	40	C34876	19	16	C35006	13	42
C34798	13	44	C34876	19	20	C35006	19	11
C34798	13	65	C34876	19	26	C35006	19	15
C34798	15	73	C34876	21	35	C35006	21	17
C34798	15	84	C34876	21	3	C35015	23	13
C34798	15	93	C34881	17	12	C35016	23	14
C34798	15	96	C34890	13	50	C35017	23	12
C34798	19	4	C34892	9	26	C35018	23	7
C34798	19	6	C34892	11	21	C35021	23	10
C34798	19	9	C34895	19	3	C35022	23	15
C34798	19	13	C34899	9	36	C35023	23	16
C34798	19	17	C34899	15	72	C35024	21	20
C34798	19	21	C34899	15	83	C35024	23	18
C34798	19	35	C34899	15	92	C35024	23	34
C34798	19	38	C34901	21	30	C35030	23	2
C34798	19	43	C34902	15	86	C35030	23	6
C34798	19	46	C34903	15	85	C35032	23	32
C34798	19	49	C34904	13	61	C35033	23	22
C34798	21	18	C34905	15	87	C35035	23	4
C34798	21	27	C34908	9	7	C35036	23	35A
C34798	21	36	C34908	9	27	C35049	25	2
C34800	9	9	C34908	9	71	C35050	25	1
C34800	9	19	C34908	21	3	C35052	25	18
C34802	7	76	C34915	15	105	C35053	27	7
C34802	13	29	C34916	15	98	C35054	13	4
C34802	19	41	C34916	15	107	C35054	27	4
C34806	5	52	C34917	11	6	C35064	5	1
C34806	9	13	C34917	11	30	C35065	5	2
C34806	9	16	C34917	11	37	C35066	5	3
C34806	9	60	C34917	15	108	C35067	5	4
C34806	13	35	C34918	11	38	C35068	5	5
C34806	13	47	C34918	15	109	C35069	5	6
C34806	21	29	C34920	11	32	C35070	5	7
C34806	23	17	C34920	15	102	C35071	5	8
C34808	7	72	C34922	23	19	C35072	5	9
C34814	5	16	C34925	17	11	C35073	5	10
C34814	11	10	C34939	13	57	C35076	5	14
C34814	13	13	C34939	13	59	C35077	5	19
C34814	13	62	C34950	21	7	C35078	5	20
C34814	15	88	C34950	21	24	C35079	5	21
C34814	21	39	C34951	21	6	C35080	5	22
C34816	7	66	C34951	21	23	C35081	5	23
C34816	15	91	C34960	9	46	C35082	5	26
C34817	5	17	C34960	9	49	C35083	5	29
C34823	9	61	C34965	17	17	C35083	5	32
C34824	9	73	C34966	17	18	C35087	5	34
C34825	9	72	C34968	9	52	C35088	5	35
C34826	9	74	C34979	15	79	C35089	5	36
C34828	21	38	C34980	15	76	C35090	5	37
C34833	23	23	C34983	19	24	C35091	5	38
C34834	5	28	C34983	19	27	C35095	5	39

NUMERICAL INDEX

PART NO.	PAGE NO.	REF. NO.	PART NO.	PAGE NO.	REF. NO.
C35096	5	40	C35167	11	2
C35097	5	41	C35172	11	7
C35098	5	42	C35173	11	8
C35100	5	44	C35174	11	23
C35100	5	48	C35174	21	15
C35100	17	16	C35182	11	17
C35100	17	22	C35183	11	18
C35101	5	45	C35186	11	20
C35102	5	47	C35192	15	78
C35111	9	34	C35193	11	33
C35112	7	70	C35195	11	36
C35113	7	71	C35195	15	106
C35113	7	83	C35207	11	29
C35114	7	73	C35237	13	31
C35115	7	65	C35239	13	37
C35116	7	77	C35239	13	41
C35117	7	79	C35240	13	39
C35118	7	80	C35240	13	43
C35120	7	82	C35240	21	9
C35120	7	84	C35242	13	45
C35122	7	85	C35243	5	50
C35123	9	1	C35243	13	20
C35124	9	2	C35243	13	46
C35124	9	23	C35244	13	48
C35124	9	35	C35246	13	51
C35124	9	38	C35247	13	52
C35124	15	71	C35253	15	74
C35125	9	5	C35254	15	75
C35126	9	6	C35255	15	77
C35127	9	8	C35256	15	80
C35128	9	10	C35257	15	81
C35129	9	11	C35258	15	82
C35129	9	58	C35259	15	89
C35129	9	69	C35264	17	2
C35130	9	12	C35265	17	3
C35130	9	59	C35278	17	9
C35131	9	14	C35279	17	10
C35132	9	15	C35280	17	13
C35133	9	17	C35282	17	19
C35134	9	18	C35284	13	56
C35137	9	22	C35284	21	10
C35139	9	24	C35289	17	24
C35139	19	40	C35290	17	25
C35140	9	28	C35291	17	26
C35141	9	31	C35295	19	37
C35143	9	40	C35295	19	45
C35144	9	43	C35295	19	48
C35145	9	44	C35297	19	10
C35145	9	48	C35298	19	14
C35146	9	45	C35300	19	22
C35147	9	47	C35301	19	23
C35148	9	50	C35302	19	26
C35149	9	51	C35303	19	28
C35150	9	53	C35304	19	29
C35151	9	54	C35307	19	19
C35152	9	55	C35307	19	34
C35153	9	56	C35309	19	39
C35154	9	57	C35311	19	42
C35157	9	63	C35316	21	2
C35158	9	64	C35327	21	13
C35159	9	65	C35333	23	3
C35160	9	66	C35334	9	20
C35161	9	67	C35334	23	5
C35162	9	68	C35334	23	21
C35163	9	70	C35334	23	26
C35164	9	75	C35336	23	8
C35165	9	76	C35337	23	9
C35166	9	77	C35339	23	11

PART NO.	PAGE NO.	REF. NO.
C35343	23	25
C35345	23	27
C35346	23	28
C35348	23	30
C35349	23	31
C35350	23	33
C35351	23	35B
C35354	25	6
C35357	25	9
C35359	25	11
C35360	25	12
C35361	25	13
C35362	25	15
C35366	27	1
C35368	27	6
C35369	27	8
C35371	21	37
C35374	5	12
C35375	5	13
C35375	11	15
C35377	5	30
C35379	5	33
C35380	5	43
C35382	5	53
C35384	7	64
C35385	7	74
C35386	7	81
C35388	9	21
C35390	11	3
C35391	11	4
C35392	11	5
C35393	11	11
C35394	11	12
C35395	11	13
C35396	11	14
C35397	11	16
C35398	11	19
C35399	11	24
C35400	11	25
C35401	11	26
C35402	11	27
C35403	11	28
C35404	11	34
C35405	13	2
C35405	31	
C35406	13	3
C35407	13	7
C35408	13	8
C35409	13	9
C35410	13	10
C35411	13	14
C35412	13	15
C35413	13	16
C35414	13	17
C35415	13	18
C35416	13	21
C35417	13	22
C35418	13	23
C35419	13	24
C35420	13	25
C35422	13	28
C35423	13	32
C35424	13	33
C35425	13	36
C35426	13	49
C35427	13	53
C35428	13	54
C35429	13	58

NUMERICAL INDEX

PART NO.	PAGE NO.	REF. NO.	PART NO.	PAGE NO.	REF. NO.
C35430	13	60	182-549	35	16
C35431	13	63	187-1037	39	1
C35432	13	64	187-1328	41	12
C35433	15	70	187-1508	33	7
C35434	15	94	187-1510	37	40
C35435	15	97	187-1510	39	11
C35436	15	99	192-3	39	19
C35437	15	100	193-25	35	5
C35438	15	103	193-25	35	11
C35439	17	4	193-25	39	12
C35440	17	5	221-843	33	11
C35441	17	6			
C35442	17	7			
C35443	17	8			
C35444	17	14			
C35445	17	15			
C35446	17	20			
C35447	17	23			
C35448	19	1			
C35449	19	18			
C35450	19	36			
C35451	19	44			
C35452	19	47			
C35453	19	50			
C35454	21	4			
C35455	21	5			
C35456	21	8			
C35457	21	11			
C35458	21	12			
C35459	21	16			
C35460	21	19			
C35461	21	21			
C35462	21	22			
C35463	21	28			
C35464	21	31			
C35465	21	32			
C35466	21	33			
C35467	23	1			
C35468	23	24			
C35469	23	29			
C35470	25	4			
C35471	25	5			
C35472	25	7			
C35473	25	8			
C35474	25	10			
C35475	25	16			
C35476	25	17			
C35477	25	19			
C35478	25	20			
C35479	27	2			
C35546	31				
C35547	31	10			
C35568	5	51			
C35568	13	19			
C35568	23	20			
C355796	21	34			
011-312	39	6			
041-24	37	12			
129-6	39	13			
129-7	39	7			
136-103	39	16			
138-251	37	6			
138-2032	41	9			
163-4	39	18			
177-97	37	29			
182-84	35	4			
182-87	37	4			
182-90	35	10			