

COMPACT TRACTORS
 With Power Steering
 and Onan Engines
 3016PS, 3018PS, 3020PS - ALL
 4016PS, 4018PS, 4020PS - ALL
 4016* PIN 14149628 to 14170800
 Parts Catalog 8-3121

*this model does not
 have power steering

NOTE: Parts Catalog 8-3121
 replaces 8-3120

9-95-RP-500-360

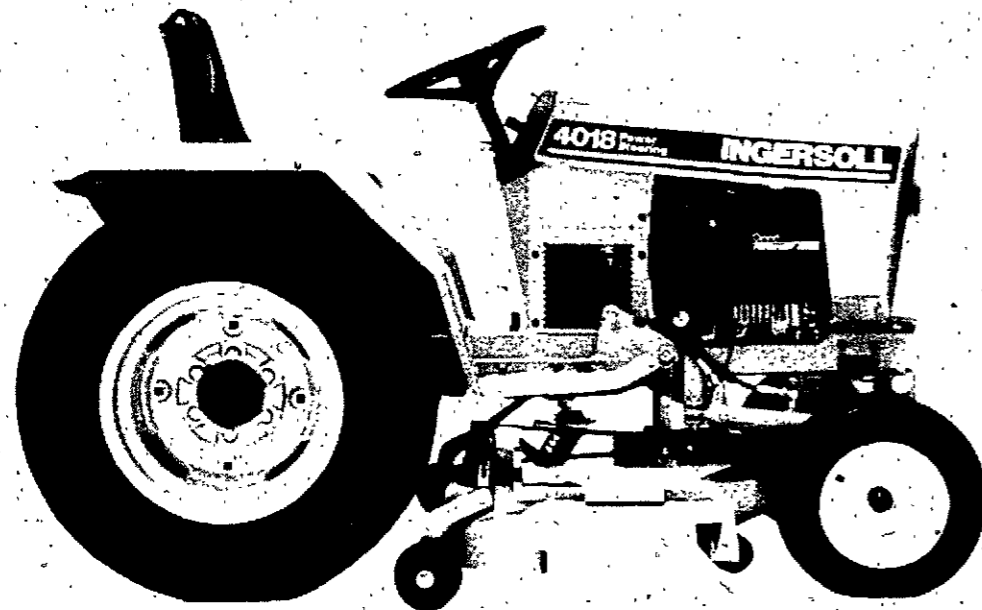

TRACTOR MODEL 4018PS SHOWN

MODEL 3016PS, 3018PS, 3020PS, 4016, 4016PS, 4018PS, 4020PS COMPACT TRACTORS

PRODUCT IDENTIFICATION NUMBERS (P.I.N.)
 OR SERIAL NUMBERS (S/N)

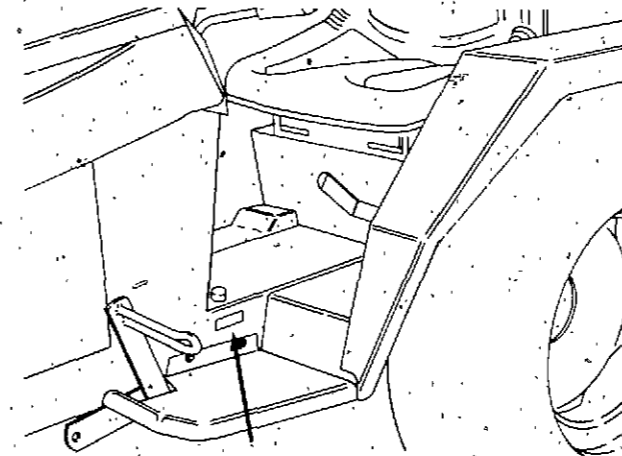

TRACTOR MODEL AND P.I.N.
 OR SERIAL NUMBERS

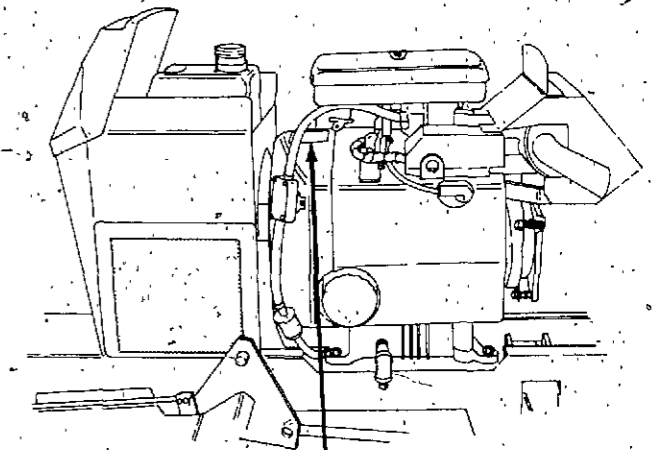

ENGINE MODEL, SERIAL AND
 SPECIFICATION NUMBERS

NOTE: In this catalog there are references to serial numbers. To order the correct part use these serial numbers as a guide.

ENGINE IDENTIFICATION

TRACTOR MODEL

3016PS, 4016PS, 4016

3018PS, 4018PS

4020PS

ENGINE MODEL

C33235
 ONAN P216G-I
 SPEC. NO. 10904C

C33236
 ONAN P218G-I
 SPEC. NO. 10904C

C33237
 ONAN P220G-I
 SPEC. NO. 10904C

GENERAL INFORMATION

INDEX

There is an index at the front and rear of this catalog.

The front index is an alphabetical index of the major groups or assemblies.

The rear index is a numerical index of the part numbers and pages on which these numbers are shown.

ILLUSTRATION

Each illustration in this catalog shows a group of parts or components. These parts and components are aligned approximately as the parts and components on your machine. Each part and component in an illustration has a reference number. These reference numbers are in a list on the page opposite of the illustration. Next to the reference number is the part number, description and required quantity of the part shown in the illustration.

UAR - "Use as required" indicates that the part quantity is variable.

NSS - "Not sold separately" indicates that the part is only available as a component of an assembly or the part must be purchased locally. If the part is an assembly component, the description will be indented under the assembly description in the parts list.

O/L - "Obtain locally"

** - "Footnotes" are added to a part number when more information is needed for identification. They only relate to the part numbers indicated.

PARTS ORDERS

All orders must include the following information:

1. Correct part number.
2. Complete description of part or component.
3. Total quantity of each part or component.
4. Product model number.
5. All necessary product identification numbers.
6. Method for sending the parts.
7. Complete and correct address.

CATALOG REVISIONS

As the product changes, new pages will be available for your catalog. A notice will be issued.

IMPORTANT: Put all revisions into the catalog as soon as possible.

RIGHT HAND AND LEFT HAND IDENTIFICATION

The words right hand (RH) and left hand (LH) as used in this catalog indicate the direction while you are in the operator's seat in the normal operating position.

INDENTED DESCRIPTIONS

An assembly can have many components. The components of an assembly are indicated by an indented description. The quantity for an indented part is the total needed for that complete assembly. See the example.

REF.	PART NO.	DESCRIPTION	REQ'D
	C 55159	CYLINDER ASSY - rear steering	1
28	C 56208	SOCKET ASSY - rear cylinder	1
29	C 55956	PLUG - adjusting, socket assy	1
30	C 55957	SEAT - socket ball	2
31	C 56210	SPRING - socket	1
32	C 56209	SEAT - socket spring	1
33	G 45175	CLAMP ASSY - socket assy	1
	16- 836	BOLT - 1/2" x 2-1/4" N.F. hex	1
34	132- 104	PIN - cotter, 3/16" x 3"	1
35	C 55889	STUD - ball, socket & cylinder	2
36	13- 410	BOLT - 1/4" x 5/8" N.C., hex	4
37	92- 4	LOCK WASHER - 1/4" SAE	4

ALPHABETICAL INDEX

ENGINE SECTION

	PAGE		PAGE
Air Cleaner	17	Flywheel	5
Battery	59	Fuel Pump	15
Breather, Crankcase	17	Fuel System	15
Camshaft	5	Gasket Kits	7-9
Carburetor	15-19	Governor	13-21
Choke Linkage	19	Muffler	23
Connecting Rod	5	Shields	21-23
Crankshaft	5	Oil Pan	11
Cylinder Block	7-9	Riston	5
Cylinder Head	7-9	PTO Clutch	25
Electrical System	65-69	Rotor, Ignition	13
Engine Block & Attaching Parts	7-9	Spark Plug	65-67
Exhaust System	23	Starter	63
Filter, Breather	17	Tank, Fuel	15
Filter, Fuel	15	Throttle Linkage	19
Filter, Oil	11	Valves	7-9

BASIC TRACTOR SECTION

Axle, Front	39	Hydraulics	45-61
Axle, Rear	43	Adapter, Pump Drive	55
Baffles & Shrouds	21-23	Hoses, Lines & Fittings	45-61
Brakes	41	Motor, Hydraulic Drive	55
Control, Speed	59	Pump	53
Decals	71	Valve, Control	57
Electrical System	65-69	Linkage, Valve, Control	59
F27 Three Point Hitch Adapter	85	Hydraulic Lift	61
Fenders	33-35	PTO (Hydraulic)	73-75
Frame	27-29	Instruments	65-67
Grille	31	K22 and K24 Sleeve Hitch	81
H13 Weight Box	87	L11 Counterweight Kit	85
H18 Counterweight Brackets	87	Mounts, Engine	27-29
HFC34A Flow Control Kit	77	Mounts, Heat Exchanger	45-49
HFC34D Flow Control Kit	79	PTO Clutch (electric)	25
HH34 Three Point Hitch	83	Reflector, rear	69
HP31, HP41 Hydraulic PTO	73	Seat, Operator's	33-35
HP34 Hydraulic PTO	75	Steering, Power	51
Headlights	69	Steering Wheel & Gear (manual)	37
Hitch, Tow	59	Tool Tray	33-35
Hood	31	Transmission	43
		Wheels, Front & Rear	41
		WW30, WW30W, WW40 Wheel Weights	89

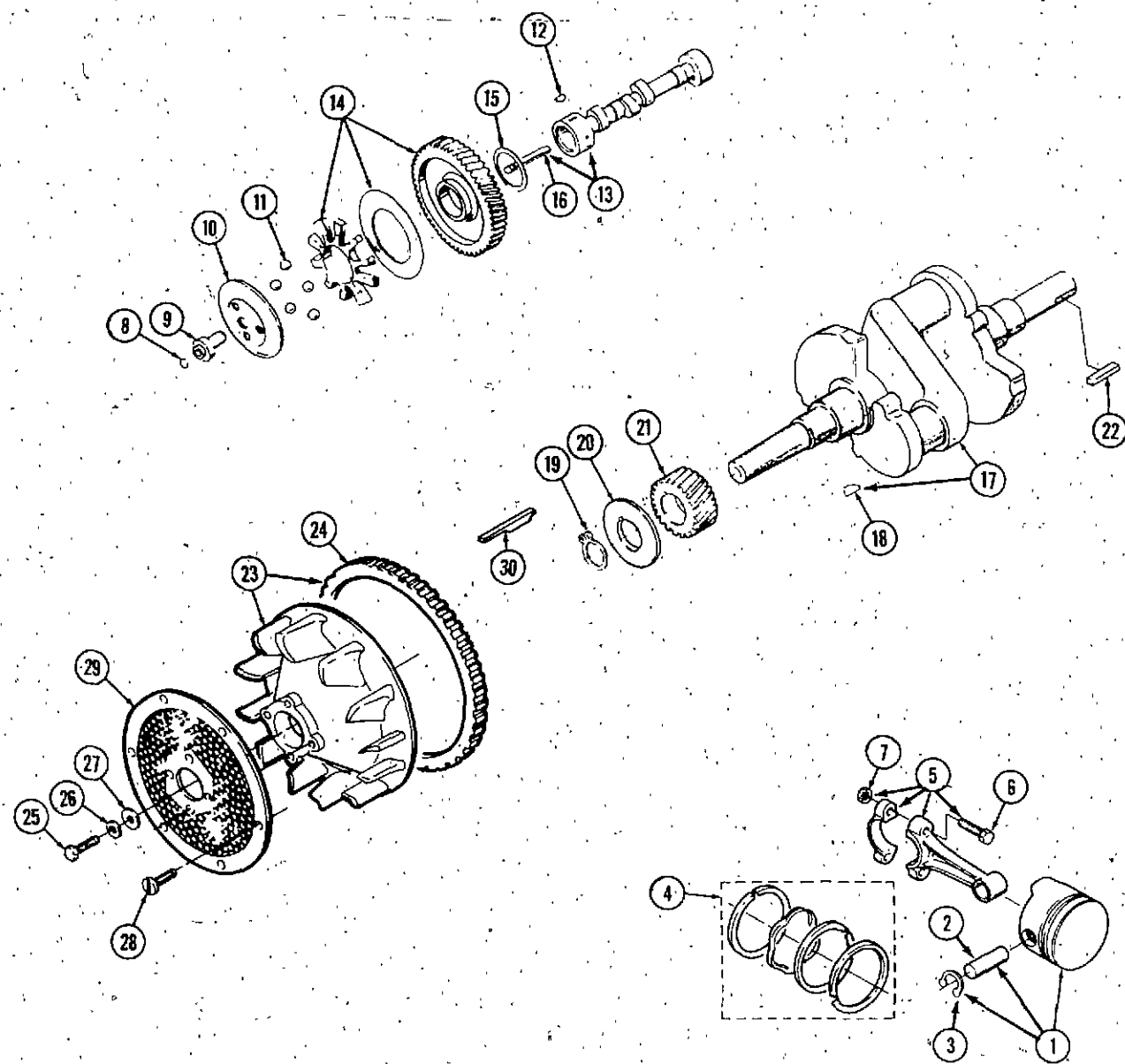

PISTON, CRANKSHAFT, FLYWHEEL AND CAMSHAFT

REF.	PART NO.	DESCRIPTION	REQ'D
1	C 40793	PISTON - standard (includes pin and retaining ring)	2
1	C 24932	PISTON - .005 (0.13 mm) oversize (includes pin and retaining ring)	2
1	C 40794	PISTON - .010 (0.25 mm) oversize (includes pin and retaining ring)	2
1	C 40795	PISTON - .020 (0.51 mm) oversize (includes pin and retaining ring)	2
1	C 40796	PISTON - .030 (0.76 mm) oversize (includes pin and retaining ring)	2
1	C 24936	PISTON - .040 (1.02 mm) oversize (includes pin and retaining ring)	2
2	C 29972	PIN - piston	2
3	C 20241	RING - retaining	4
4	C 29739	RING SET - piston (standard)	2
4	C 24938	RING SET - piston .005" (0.13 mm) oversize	2
4	C 24939	RING SET - piston .010" (0.25 mm) oversize	2
4	C 24940	RING SET - piston .020" (0.51 mm) oversize	2
4	C 24941	RING SET - piston .030" (0.76 mm) oversize	2
4	C 24942	RING SET - piston .040" (1.02 mm) oversize	2
5	C 29750	CONNECTING ROD - (standard) includes nut and bolt	2
5	C 29751	CONNECTING ROD - .010" (0.25 mm) undersize, includes nut & bolt (3016PS, 4016, 4016PS)	2
5	C 20204	CONNECTING ROD - .020" (0.51 mm) undersize, includes nut & bolt (3016PS, 4016, 4016PS)	2
5	C 20205	CONNECTING ROD - .030" (.076 mm) undersize, includes nut & bolt (3016PS, 4016, 4016PS)	2
5	C 25383	CONNECTING ROD - (standard) includes nut & bolt (3018PS, 3020PS, 4018PS, 4020PS)	2
5	C 25384	CONNECTING ROD - .010" (0.25 mm) undersize, includes nut & bolt (3018PS, 3020PS, 4018PS, 4020PS)	2
5	C 25385	CONNECTING ROD - .020" (0.51 mm) undersize, includes nut & bolt (3018PS, 3020PS, 4018PS, 4020PS)	2
5	C 25386	CONNECTING ROD - .030" (0.76 mm) undersize, includes nut & bolt (3018PS, 3020PS, 4018PS, 4020PS)	2
6	C 25774	BOLT - connecting rod 5/16" special N.F.	4
7	C 25775	NUT - lock, connecting rod 5/16" N.F.	4
8	C 20223	RING - retaining	1
9	C 24325	HUB - governor cup	1
10	C 24326	CUP - governor	1
11	211- 216	BALL - governor	5
12	126- 9	KEY - woodruff 1/8" x 1/2"	1
13	C 32468	CAMSHAFT - (includes pin) (3016PS, 3018PS, 4016, 4016PS, 4018PS)	1
13	C 32469	CAMSHAFT - (includes pin) (3020PS, 4020PS)	1
14	C 22261	GEAR ASSEMBLY - camshaft	1
15	C 20229	WASHER - thrust	1
16	C 20233	PIN - center	1
17	C 32284	CRANKSHAFT - engine (3016PS, 4016, 4016PS)	1
17	C 32285	CRANKSHAFT - engine (3018PS, 3020PS, 4018PS, 4020PS)	1
18	126- 9	KEY - woodruff, crankshaft gear	1
19	C 20218	RING - retaining	1
20	C 20219	WASHER - special	1
21	C 22262	GEAR - crankshaft	1
22	C 31976	KEY - square, clutch	1
23	C 32286	FLYWHEEL - engine	1
24	C 20226	GEAR - ring, flywheel	1
25	C 32473	BOLT - flywheel	1
26	C 32463	WASHER - special	1
27	C 20303	WASHER - special	6
28	C 32464	SCREW - #10-24 x 3/8 flange lock	6
29	C 32287	SCREEN - flywheel	1
30	C 32288	KEY - 3/16" x 2" special, flywheel	1

CYLINDER BLOCK

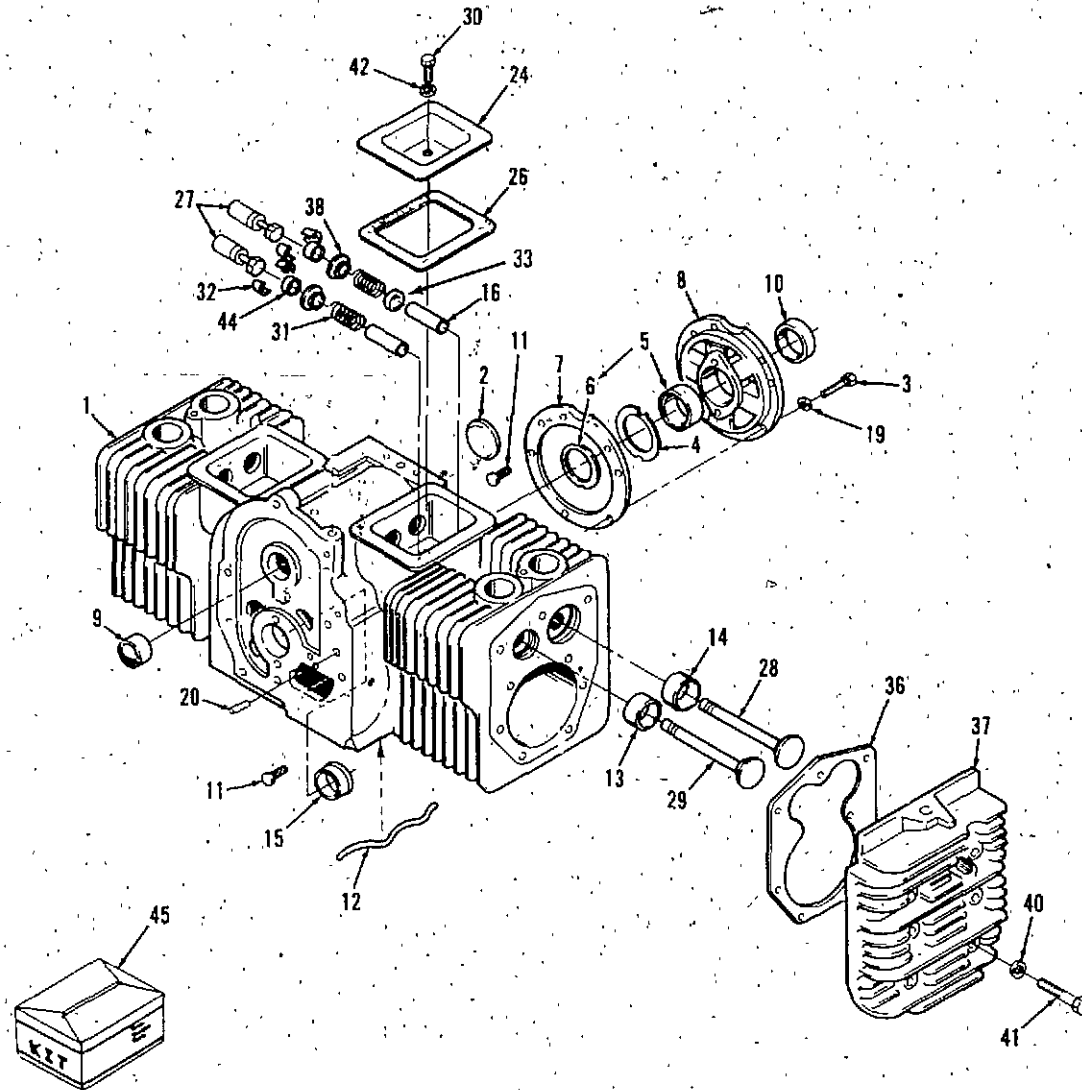

REF.	PART NO.	DESCRIPTION	REQ'D
1	C 33243	BLOCK ASSEMBLY - short (3016PS, 4016, 4016PS) includes cylinder and crankcase, all bearings, crankshaft, camshaft, timing gear, connecting rods, pistons, piston rings, valves, oil pump and breather tube (does not include gasket set)	1
1	C 33244	BLOCK ASSEMBLY - short (3018PS, 3020PS, 4018PS, 4020PS) includes cylinder and crankcase, all bearings, crankshaft, camshaft, timing gear, connecting rods, pistons, piston rings, valves, oil pump and breather tube (does not include gasket set)	1
2	41- 26	PLUG - welch	1
3	113- 208	BOLT - 3/8" - 16 x 1-1/4"	5
4	C 20256	SHIM - end play, crankshaft (.005")	UAR
5	C 22618	BEARING - crankshaft, rear (includes thrust washer) (standard)	1
5	C 22619	BEARING - crankshaft, rear .002" (0.05 mm) undersize	1
5	C 22620	BEARING - crankshaft, rear .010" (0.25 mm) undersize	1
5	C 22621	BEARING - crankshaft, rear .020" (0.51 mm) undersize	1
5	C 22622	BEARING - crankshaft, rear .030" (0.76 mm) undersize	1
6	C 20267	WASHER - thrust	2
7	C 20268	GASKET - bearing plate	1
8	C 20269	PLATE - bearing, rear	1
9	C 20270	BEARING - camshaft 3/4" length (service part is 5/16" length)	2
10	C 20271	SEAL - oil, crankshaft rear	1
11	C 20272	PIN - drive, bearing stop	4
12	C 24946	TUBE - oil	1
13	C 29974	INSERT - valve seat, exhaust (standard)	2
13	C 29975	INSERT - valve seat, exhaust .002" (0.05 mm) oversize	2
13	C 29976	INSERT - valve seat, exhaust .005" (0.13 mm) oversize	2
13	C 29977	INSERT - valve seat, exhaust .010" (0.25 mm) oversize	2
13	C 29978	INSERT - valve seat, exhaust .025" (0.64 mm) oversize	2
14	C 20287	INSERT - valve seat, intake (standard)	2
14	C 20289	INSERT - valve seat, intake .005" (0.13 mm) oversize	2
14	C 20290	INSERT - valve seat, intake .010" (0.25 mm) oversize	2
14	C 20291	INSERT - valve seat, intake .025" (0.64 mm) oversize	2
15	C 20295	BEARING - crankshaft, front, flanged (standard)	1
15	C 20296	BEARING - crankshaft, front .002" (0.05 mm) undersize	1
15	C 20297	BEARING - crankshaft, front .010" (0.25 mm) undersize	1
15	C 20298	BEARING - crankshaft, front .020" (0.51 mm) undersize	1
15	C 20299	BEARING - crankshaft, front .030" (0.76 mm) undersize	1
16	C 32274	GUIDE - valve, exhaust	2
16	C 32275	GUIDE - valve, intake	2
19	192- 21	LOCKWASHER - 3/8"	5
20	C 23320	PIN - alignment, gear cover	2
24	C 20250	COVER - valve	1
26	C 20251	GASKET - valve cover	2
27	C 20276	TAPPET - valve (standard)	4
27	C 20471	TAPPET - valve .002 (0.05 mm) oversize	4
27	C 20277	TAPPET - valve .005 (0.13 mm) oversize	4
28	C 32272	VALVE - intake	2
29	C 32273	VALVE - exhaust	2
30	113- 132	BOLT - 1/4" - 20 x 1-3/4"	2
31	C 32276	SPRING - valve	4
32	C 32277	LOCK - valve and spring	8

CYLINDER BLOCK

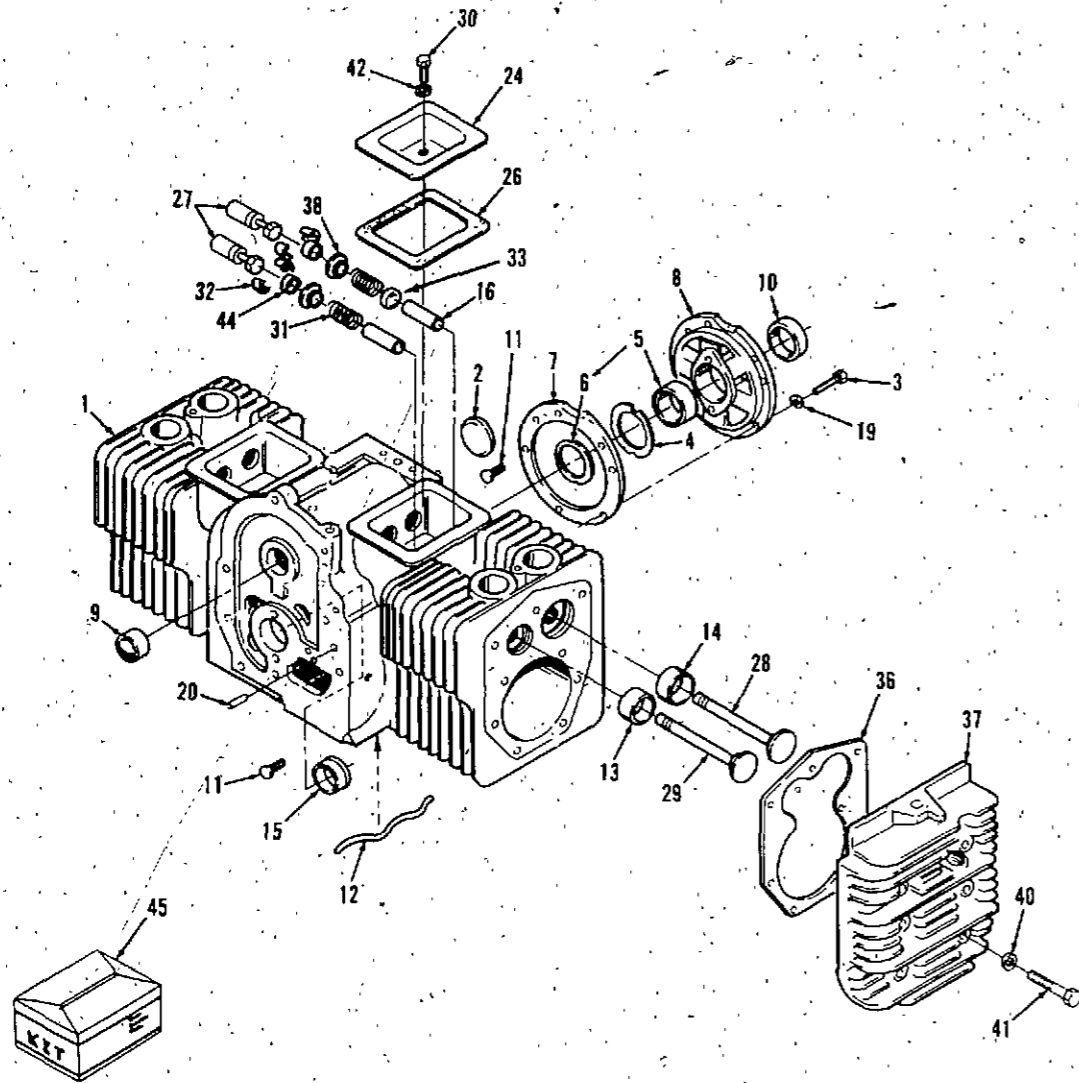

REF.	PART NO.	DESCRIPTION	REQ'D
33	C 40797	SEAL - intake valve	2
36	C 29979	GASKET - head	2
37	C 32279	HEAD - cylinder R.H.	1
37	C 32280	HEAD - cylinder L.H.	1
38	C 32281	RETAINER - valve spring	4
40	C 20248	WASHER - 5/16"	18
41	C 32440	BOLT - head 2-3/8" long	16
42	C 20247	WASHER - 1/4" copper	2
44	C 32282	CAP - valve	4
45	C 29981	KIT - gasket, complete engine (does not include bearings)	1
45	C 29982	KIT - gasket, (carbon removal/valve grind)	1

OIL BASE, PUMP, FILTER AND FILLER TUBE

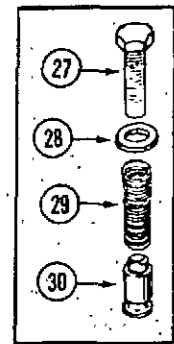

OIL BYPASS VALVE

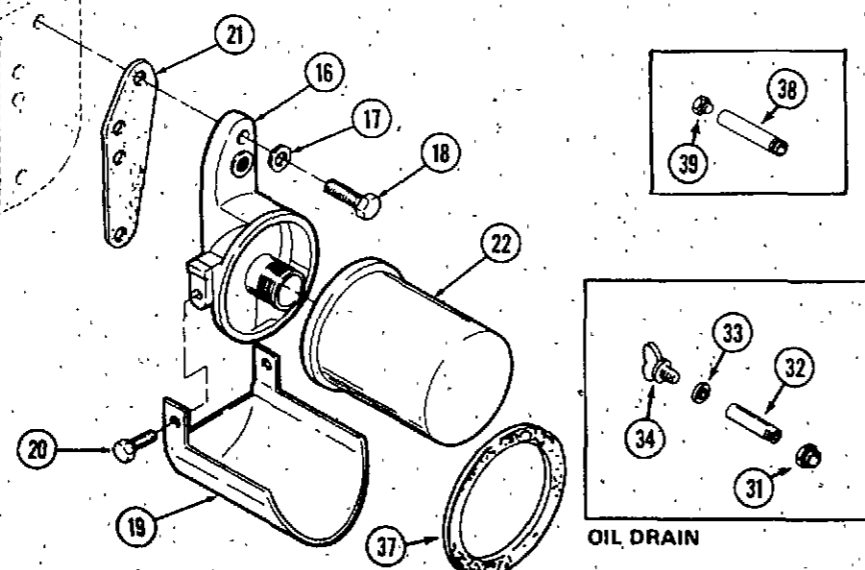
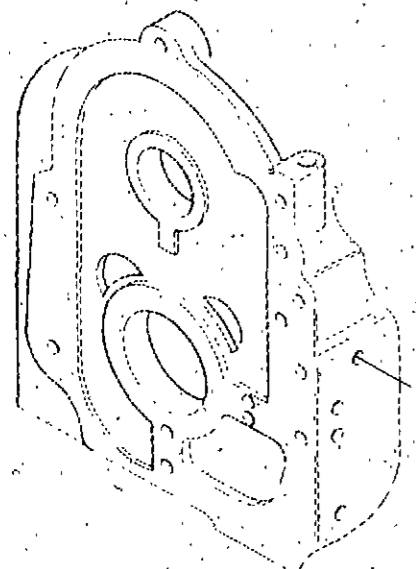
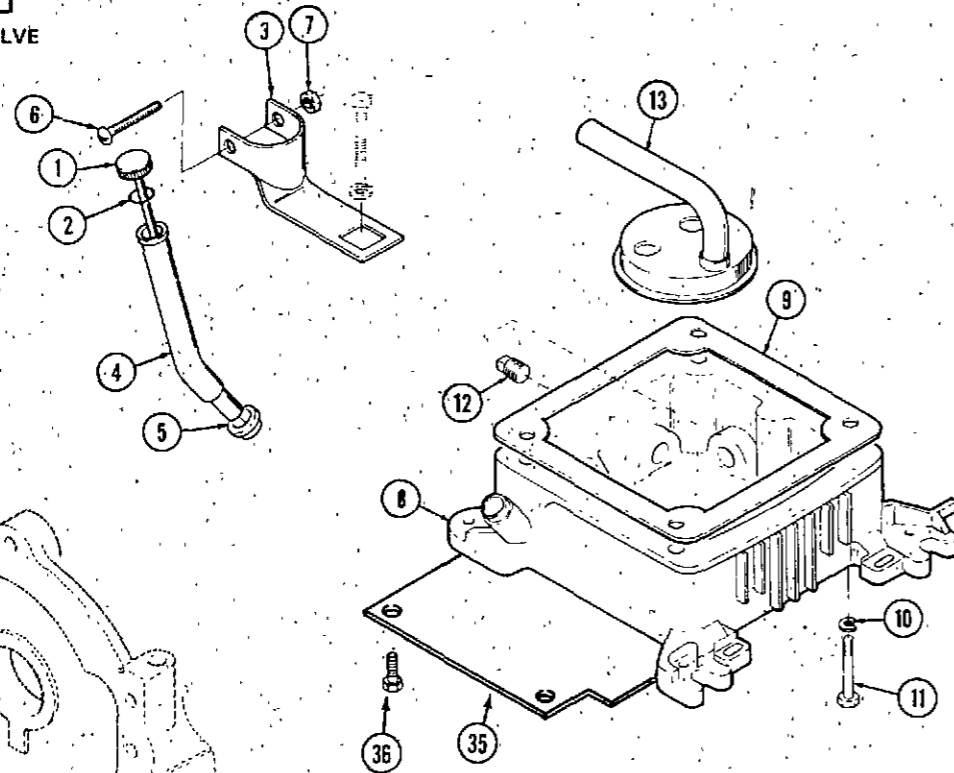
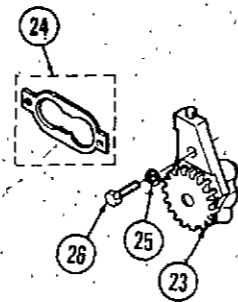

OIL DRAIN

REF.	PART NO.	DESCRIPTION	REQ'D
1	C 32290	DIPSTICK - oil level indicator	1
2	C 32465	O-RING	1
3	C 32291	BRACKET - fill tube	1
4	C 32292	TUBE - oil fill	1
5	C 32293	SEAL - tube	1
6	C 32466	SCREW - #10 x 1-1/4" panhead	1
7	C 32467	NUT - speed (type U)	1
8	C 32289	BASE - oil (includes plugs)	1
9	C 29984	GASKET - oil base	1
10	192- 21	LOCKWASHER - 3/8"	4
11	113- 252	BOLT - 3/8" - 16 x 3-3/4"	4
12	221- 3	PLUG - oil base 3/8"	2
13	C 23321	CUP - intake, oil pump	1
16	C 20565	ADAPTER - oil filter	1
17	C 20331	WASHER - 5/16" copper	2
18	113- 103	BOLT - 5/16" - 18 x 1"	2
19	C 25389	DRAIN - oil filter	1
20	182- 525	BOLT - #10 - 32 x 3/8"	2
21	C 32462	GASKET - oil filter adapter	1
22	C 26191	FILTER - oil	1
23	C 29734	PUMP - oil	1
24	C 20325	KIT - gasket, oil pump	1
25	192- 19	LOCKWASHER - 1/4"	2
26	113- 4	BOLT - 1/4" - 20 x 1"	2
27	C 32474	BOLT - 3/8" - 24 x 7/8" oil bypass	1
28	C 20574	WASHER - 3/8" copper	1
29	C 20320	SPRING - oil bypass valve	1
30	C 20322	VALVE - oil bypass	1
31	221- 86	REDUCER - pipe 3/8" - 14 to 1/4"	1
32	C 19473	NIPPLE - pipe 2.5"	1
33	C 14906	GASKET - oil drain	1
34	C 14399	PLUG - oil drain	1
35	C 33222	BAFFLE - air, oil base	1
36	182- 525	BOLT - #10 - 32 x 3/8"	1
37	C 20577	SEAL - oil filter	1
38	C 33949 **	NIPPLE - pipe 3.5"	1
39	218- 5154 **	PLUG - 1/2" - 20	1

**Use PIN and after:
 3018PS - 14181900
 4020PS - 14184000

GOVERNOR GEARCASE AND IGNITION ROTOR

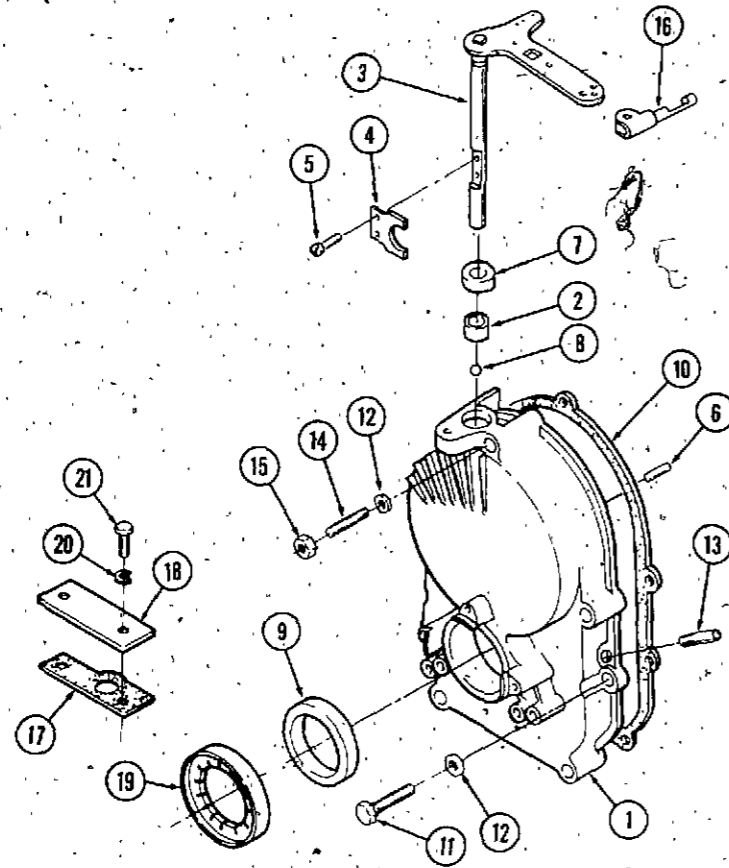

REF.	PART NO.	DESCRIPTION	REQ'D
1	C 32457	GEARCASE ASSEMBLY - governor	1
2	C 20305	BEARING - governor shaft	1
3	C 22632	SHAFT AND ARM	1
4	C 20307	YOKE - governor shaft	1
5	182- 84	SCREW - #8 - 32 x 3/8"	2
6	C 20309	PIN - governor cup stop	1
7	C 20310	SEAL - oil, governor shaft	1
8	211- 5	BALL - bearing, governor shaft	1
9	C 20312	SEAL - oil, crankshaft	1
10	C 20313	GASKET - mounting	1
11	113- 120	BOLT - 5/16" - 18 x 1-3/4"	4
12	C 20331	WASHER - 5/16" copper	5
13	C 20412	TUBE - vacuum port (included in assembly)	1
14	C 29985	STUD - gear cover	1
15	131- 911	NUT - 5/16" - 18	1
16	C 29989	CLIP - retaining	1
17	C 20345	GASKET - plate	1
18	C 32452	PLATE - plunger cover	1
19	C 32297	ROTOR - ignition	1
20	192- 19	LOCKWASHER - 1/4"	2
21	113- 2	BOLT - 1/4" - 20 x 5/8"	2

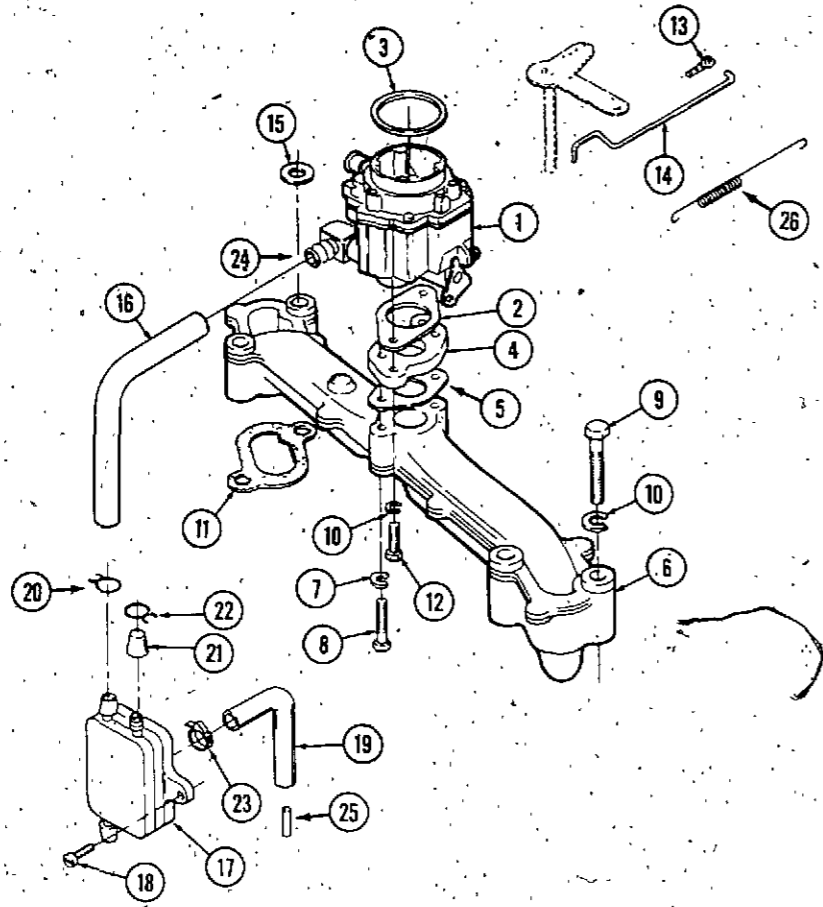

FUEL SYSTEM (ENGINE)

REF.	PART NO.	DESCRIPTION	REQ'D
1	C 29868	CARBURETOR - fuel (3016PS, 3018PS, 4016, 4016PS, 4018PS) repairs page 19	1
1	C 29869	CARBURETOR - fuel (3020PS, 4020PS) repairs page 19	1
2	C 29969	GASKET - carburetor mounting	1
3	C 29944	SEAL - "O" ring	1
4	C 29952	ADAPTER - carburetor	1
5	C 29953	GASKET - adapter	1
6	C 40896	MAINIFOLD - intake	1
7	192- 19	LOCKWASHER - 1/4"	2
8	113- 65	BOLT - 1/4" - 20 x 1-3/8"	2
9	113- 121	BOLT - 5/16" - 18 x 2"	4
10	192- 20	LOCKWASHER - 5/16"	6
11	C 26202	GASKET - manifold	2
12	113- 103	BOLT - 5/16" - 18 x 1"	2
13	C 20360	CLIP - retaining, control rod to carburetor	1
14	C 29988	ROD - governor control	1
15	195- 2027	WASHER - 5/16"	1
16	NSS	HOSE - fuel (use C28937 cut to length)	1
17	C 29959	PUMP - fuel	1
18	182- 559	SCREW - tapping #10 - 24 x 5-8"	2
19	NSS	HOSE - vacuum (use C28937 cut to length)	1
20	214- 103	CLAMP - hose 1/2" (wire)	UAR
21	C 20411	CAP - fuel outlet	UAR
22	NSS	CLAMP - hose 7/16" (wire) (use C32376)	UAR
23	C 32376	CLAMP - hose 1/2" (worm drive)	1
24	C 10678	ELBOW - hose 90°	1
25	C 20412	TUBE - vacuum	1
26	C 33406	SPRING - governor rod (optional)	1

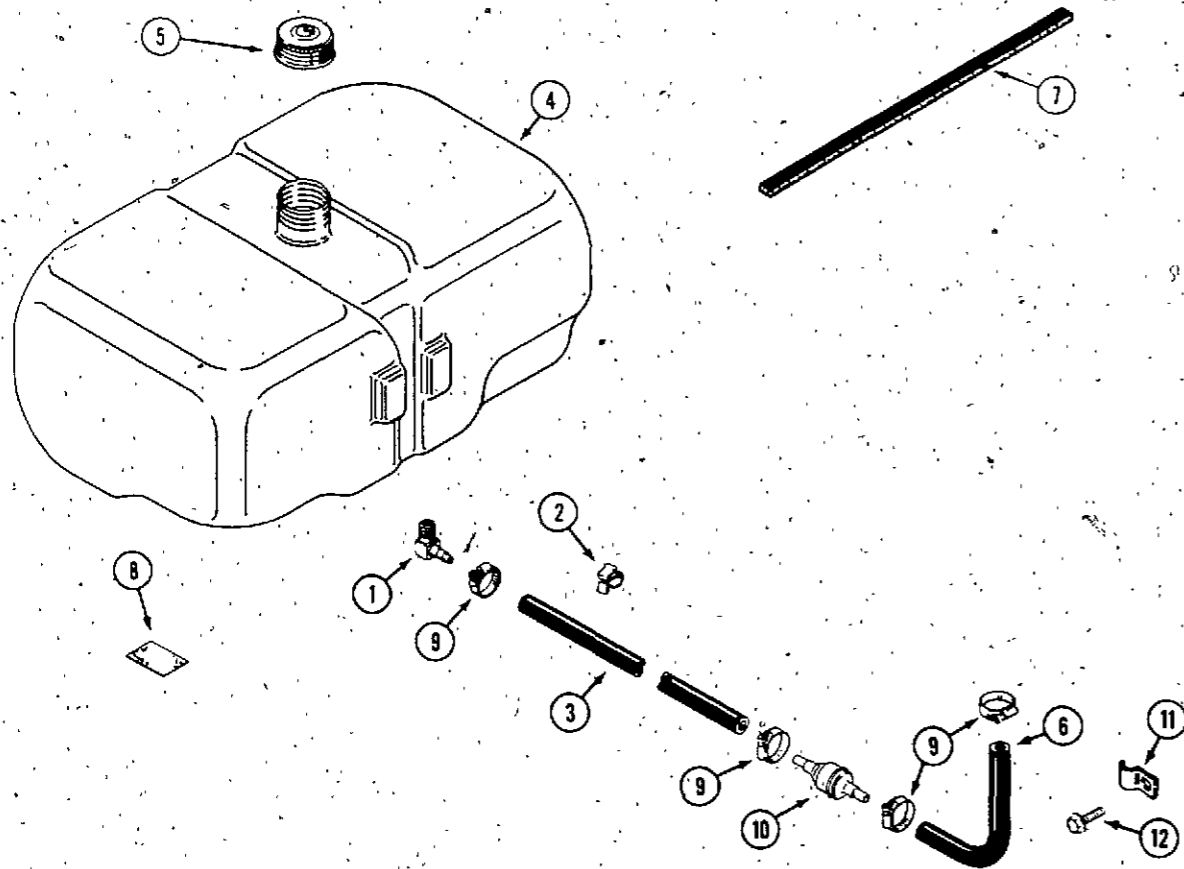

FUEL SYSTEM (TRACTOR)

1	C 10678	ELBOW - hose 90°	1
2	C 28962	RETAINER - fuel line	1
3	NSS	HOSE - fuel line (use C28937 cut to length)	1
4	NSS	TANK - fuel (use C44818, C44819)	1
5	C 11529	CAP - fuel tank (includes insert) (1.5")	1
5	C 44819	CAP - fuel tank (1.75")	1
6	NSS	HOSE - fuel line (use C28937 cut to length)	1
7	C 23527	LINER - tank	1
8	C 14690	CUSHION - fuel tank	2
9	C 32376	CLAMP - hose 1/2"	4
10	C 31978	FILTER - fuel	1
11	C 24689	CLIP - "J" fuel line retaining	1
12	187- 1036	SCREW - 1/4" - 20 self tap	1

AIR CLEANER

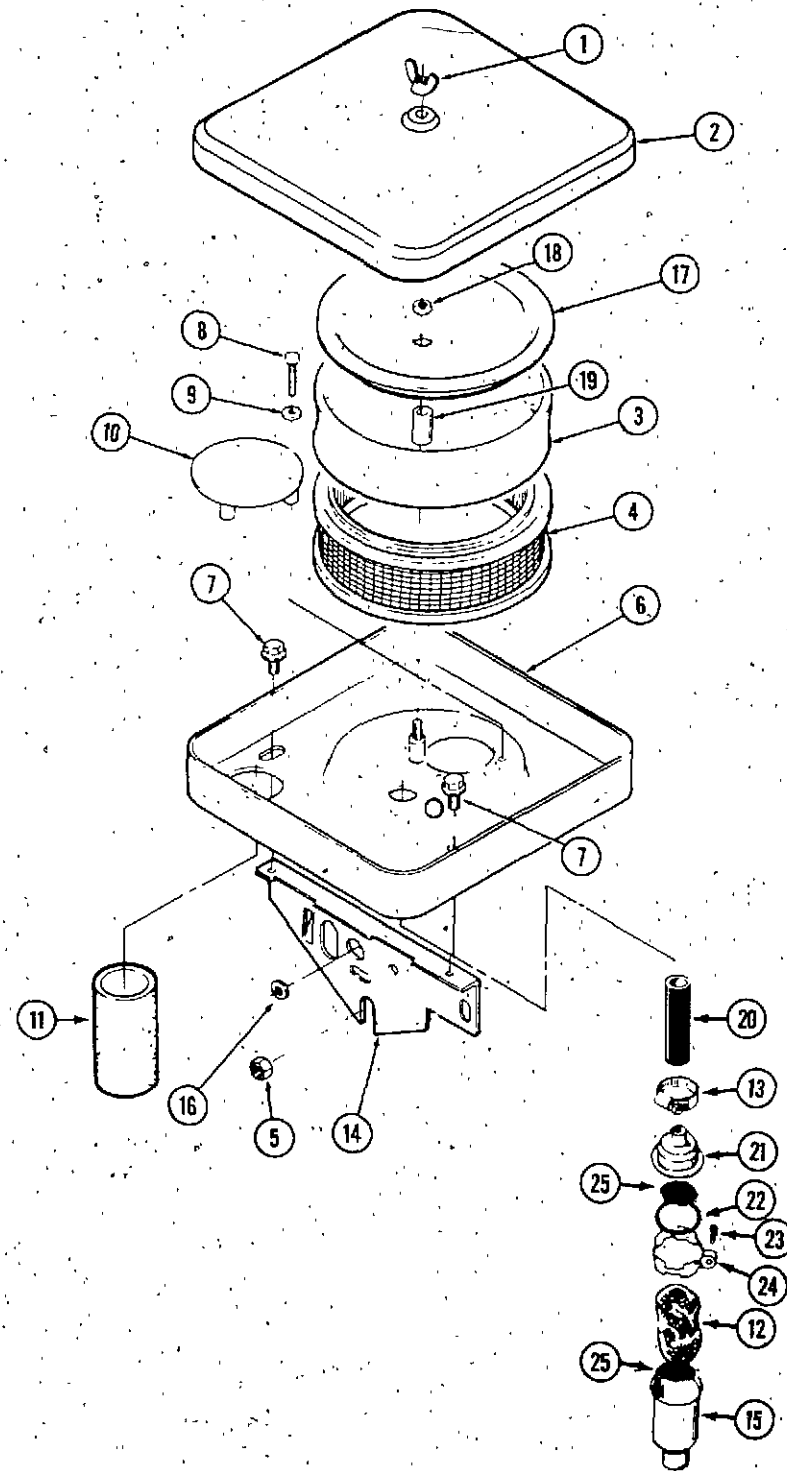

REF.	PART NO.	DESCRIPTION	REQ'D
1	C 26703	NUT - wing 1/4" - 20	1
2	C 32302	COVER - air cleaner	1
3	C 22581	PRECLEANER	1
4	C 22424	ELEMENT - air cleaner	1
5	131- 911	NUT - 5/16" - 18 flange	1
6	C 32303	HOUSING - air cleaner	1
7	187- 1036	BOLT - 1/4" - 20 x 1/2" tapping, washer head	2
8	182- 152	SCREW - machine #10 - 32 x 1-1/2"	3
9	195- 516	WASHER - #10	3
10	C 29946	DEFLECTOR - air	1
11	C 32304	TUBE - air intake	1
12	C 29948	FILTER - breather	1
13	C 32376	CLAMP - hose	1
14	C 32305	SUPPORT - air cleaner	1
15	C 33247	TUBE - breather	1
16	C 30033	GROMMET - rubber	1
17	C 32306	COVER - element	1
18	131- 71	NUT - lock 1/4" - 20	1
19	C 32451	SPACER - air cleaner stud	1
20	C 33246	HOSE - breather	1
21	C 20490	VALVE - breather cap	1
22	C 20493	"O" RING - breather cap	1
23	NSS	SCREW - #8 x 3/4" self tap	1
24	C 20536	CLAMP - breather cap	1
25	C 20504	SCREEN - breather tube	2

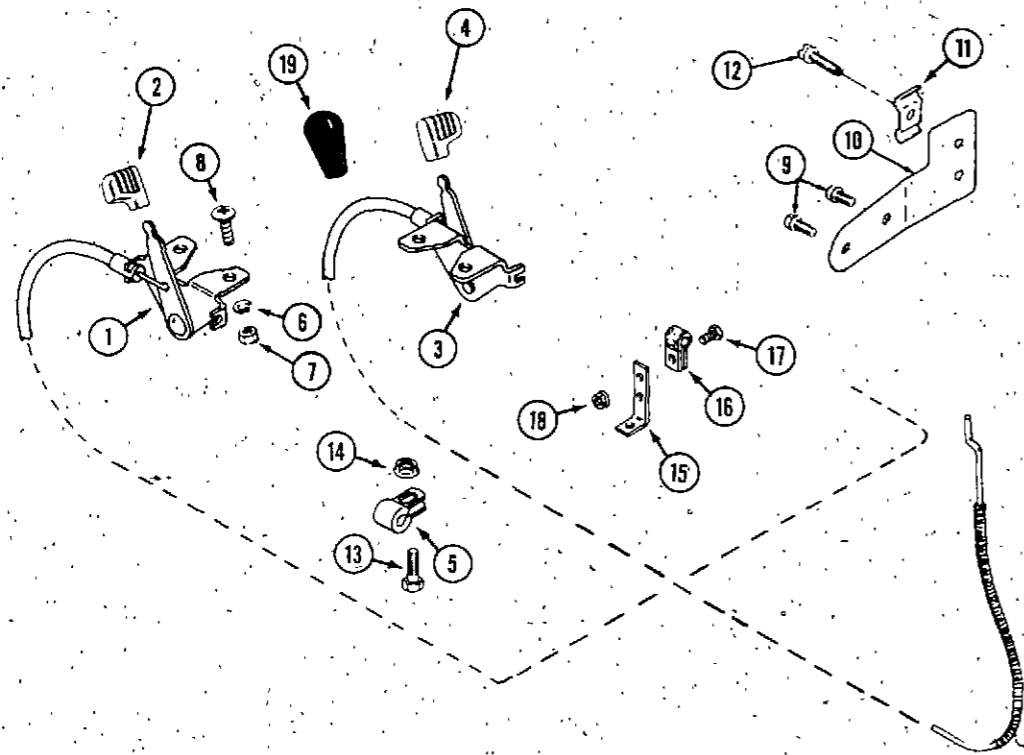

CHOKE AND THROTTLE

REF.	PART NO.	DESCRIPTION	REQ'D
1	C 33468	CONTROL - throttle	1
1	C 37226*	CONTROL - throttle	1
2	NSS	HANDLE - throttle control, orange (use C35291)	1
3	C 31893	CONTROL - choke	1
3	C 37227*	CONTROL - choke	1
4	C 30074	HANDLE - choke control, black	1
5	C 27233	CLIP - double cable	3
6	192- 18	LOCKWASHER - No. 10 (early production)	2
7	C 34117	NUT - No. 10 - 24 flange lock	2
8	182- 559	BOLT - No. 10 - 24 x 3/4" phillips, black	2
9	C 22369	BOLT - washer head #10 - 32 x 5/16"	2
10	C 29957	BRACKET - choke cable	1
11	C 29506	CLIP - retaining, choke cable	1
12	187- 1511	SCREW - tapping #10 - 32 x 1/2"	1
13	113- 1	BOLT - 1/4" - 20 x 1/2"	1
14	131- 934	NUT - 1/4" - 20 flange lock	1
15	C 37536*	BRACKET - wire stand off	1
16	C 31977*	CLIP - wire	2
17	113- 4*	BOLT - 1/4" - 20 x 1"	1
18	129- 101*	NUT - 1/4" - 20	1
19	C 35291*	KNOB - choke and throttle	2

CARBURETOR

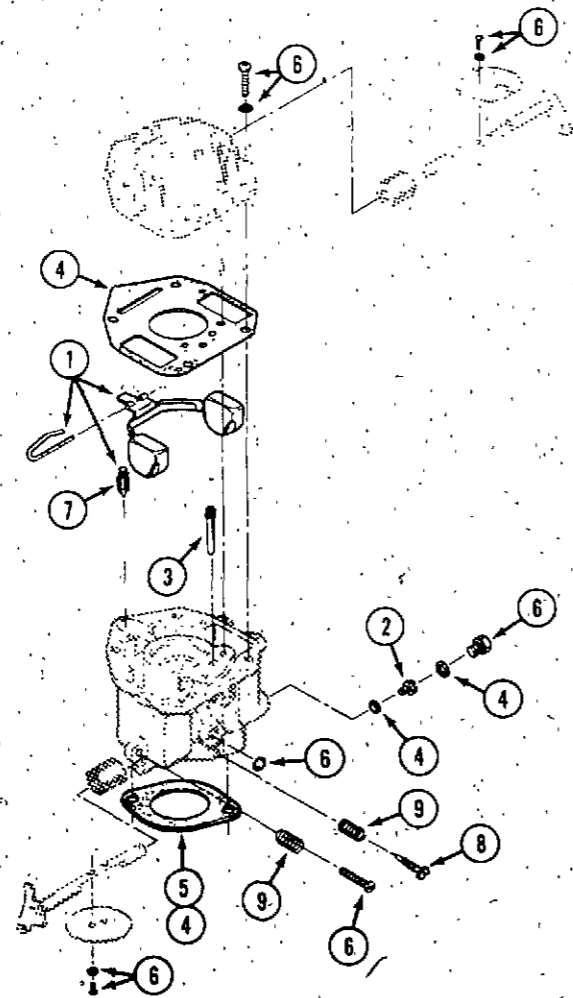

	C 29868	CARBURETOR - fuel (3016PS, 3018PS, 4016, 4016PS, 4018PS)	1
	C 29869	CARBURETOR - fuel (3020PS, 4020PS)	1
1	C 29965	KIT - float	1
2	C 29966	JET - power (3016PS, 3018PS, 4016, 4016PS, 4018PS)	1
2	C 30015	JET - power (3020PS, 4020PS)	1
3	C 29967	JET - idler	1
	C 29962	KIT - repair	1
4	NSS	GASKET AND SEAL PACKAGE	1
5	C 29969	GASKET - mounting	1
6	NSS	SCREW AND PLUG PACKAGE	1
7	NSS	VALVE - inlet	1
8	NSS	VALVE - idle adjust	1
9	NSS	SPRING - tension	2

BLOWER HOUSING AND GOVERNOR

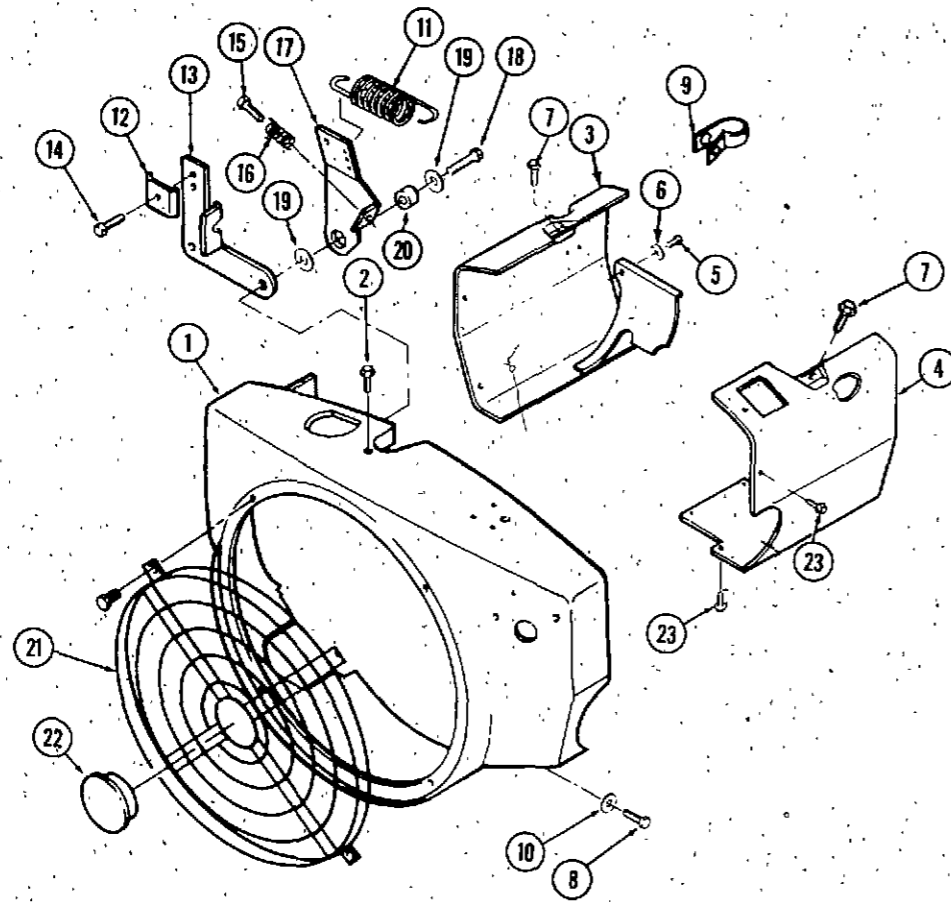

REF.	PART NO.	DESCRIPTION	REQ'D
1	C 32308	HOUSING - blower	1
2	163- 22	SCREW - tapping, washerhead 1/4" - 20 x 7/16"	1
3	C 32444	HOUSING - cylinder air L.H.	1
4	C 32445	HOUSING - cylinder air R.H.	1
5	187- 1073	SCREW - tapping, washerhead 1/4" - 20 x 5/8"	2
6	195- 102	WASHER - 1/4"	2
7	C 32446	BOLT - 5/16" - 18 x 3/4" washerhead	2
8	187- 1073	SCREW - 1/4" - 20 x 5/8" tapping, washerhead	4
9	C 32447	CLAMP - wire	1
10	195- 518	WASHER - 1/4"	4
11	C 20376	SPRING - governor	1
12	C 29506	CLAMP - cable	1
13	C 28719	BRACKET - cable	1
14	187- 1511	SCREW - tapping #10 - 32 x 1/2"	1
15	182- 49	SCREW - tapping #6 - 32 x 5/8"	1
16	C 20371	SPRING - idle setting	1
17	C 32311	ARM - governor	1
18	121- 3	BOLT - 1/4" - 20 x 1/2" washerhead	2
19	195- 102	WASHER - 1/4"	2
20	C 20375	BUSHING - arm, governor	1
21	NSS	SCREEN - blower housing (not used)	1
22	NSS	PLUG - screen (not used)	1
23	187- 1036	BOLT - 1/4" - 20 x 1/2" flange lock	UAF

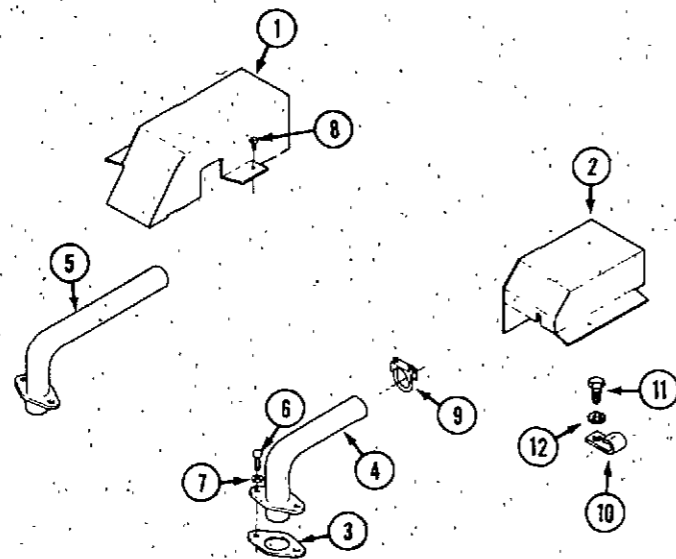

EXHAUST PIPES AND COVERS

REF.	PART NO.	DESCRIPTION	REQ'D
1	C 32321	COVER - exhaust pipe L.H.	1
2	C 32322	COVER - exhaust pipe R.H.	1
3	C 26207	GASKET - exhaust	2
4	C 32324	PIPE - exhaust R.H.	1
5	C 32325	PIPE - exhaust L.H.	1
6	61 512	BOLT - 5/16 x 5/8" socket head	4
7	192- 404	LOCKWASHER - 5/16"	4
8	NSS	SCREW - 1/4" - 20 x 3/8" washerhead (use C31597)	2
9	C 31417	CLAMP - exhaust	2
	129- 102	NUT - 5/16" - 18	2
10	C 32455	CLIP - "J" wire	1
11	187- 1908	SCREW - #10 - 16 x 5/8"	1
12	193- 70	LOCKWASHER - #10 external tooth	1

MUFFLER AND SHIELDS

1	C 31597	SCREW - 1/4" - 20 x 1/2 black	2
2	C 31415	SHIELD - head.baffle extension L.H.	1
3	C 33425	MUFFLER - exhaust	1
4	113- 208	BOLT - 3/8" - 16 x 1-1/4"	2
5	192- 21	LOCKWASHER - 3/8"	2
6	C 31420	STRAP - mounting	1
7	C 31421	SHIELD - muffler	1
8	113- 3	BOLT - 1/4" - 20 x 3/4" hex	2
9	131- 934	NUT - 1/4" - 20 flange lock	2
10	187- 1036	SCREW - 1/4" - 20 x 1/2" self-tap	4

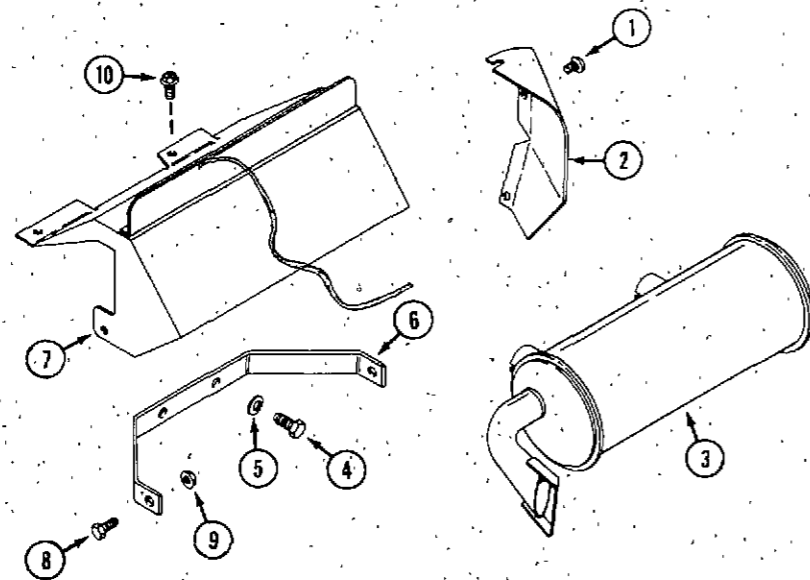

PTO ELECTRIC CLUTCH

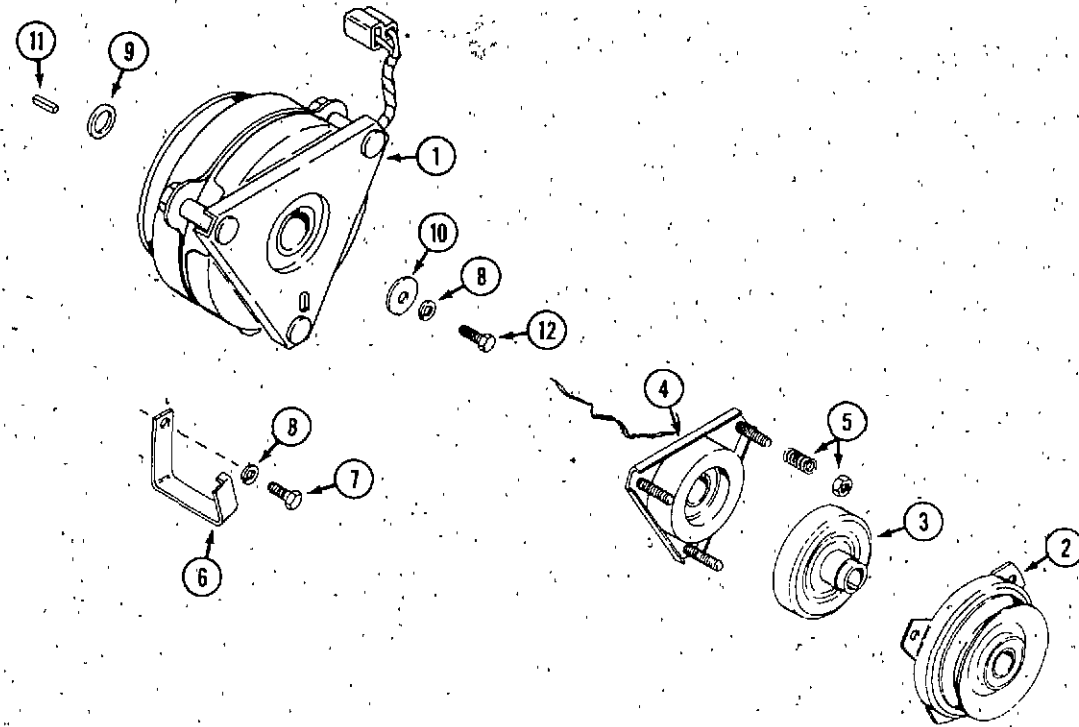

REF.	PART NO.	DESCRIPTION	REQ'D
1	C 33198	CLUTCH - PTO	1
2	C 32382	ARMATURE - clutch	1
3	C 32383	ROTOR - clutch	1
4	C 32384	FIELD - clutch	1
5	C 32381	KIT - spring and nut	1
6	C 33199	BRACKET - anti-rotation	1
7	113- 206	BOLT - 3/8" - 16 x 3/4" (secure with teflon sealant)	1
8	192- 21	LOCKWASHER - 3/8"	2
9	C 33200	SPACER - clutch	1
10	C 31615	WASHER - clamping	1
11	C 31976	KEY - 1/4" x 1/4" x 1-1/4"	1
12	114- 203	BOLT - 3/8" - 24 x 1-1/2" (use 31 ft. lbs. torque)	1

FRAME, FOOT PADS AND BELLY PAN

3018PS - before PIN 14181900
 4020PS - before PIN 14184000
 3016PS, 3020PS, 4016, 4016PS, 4018PS - ALL

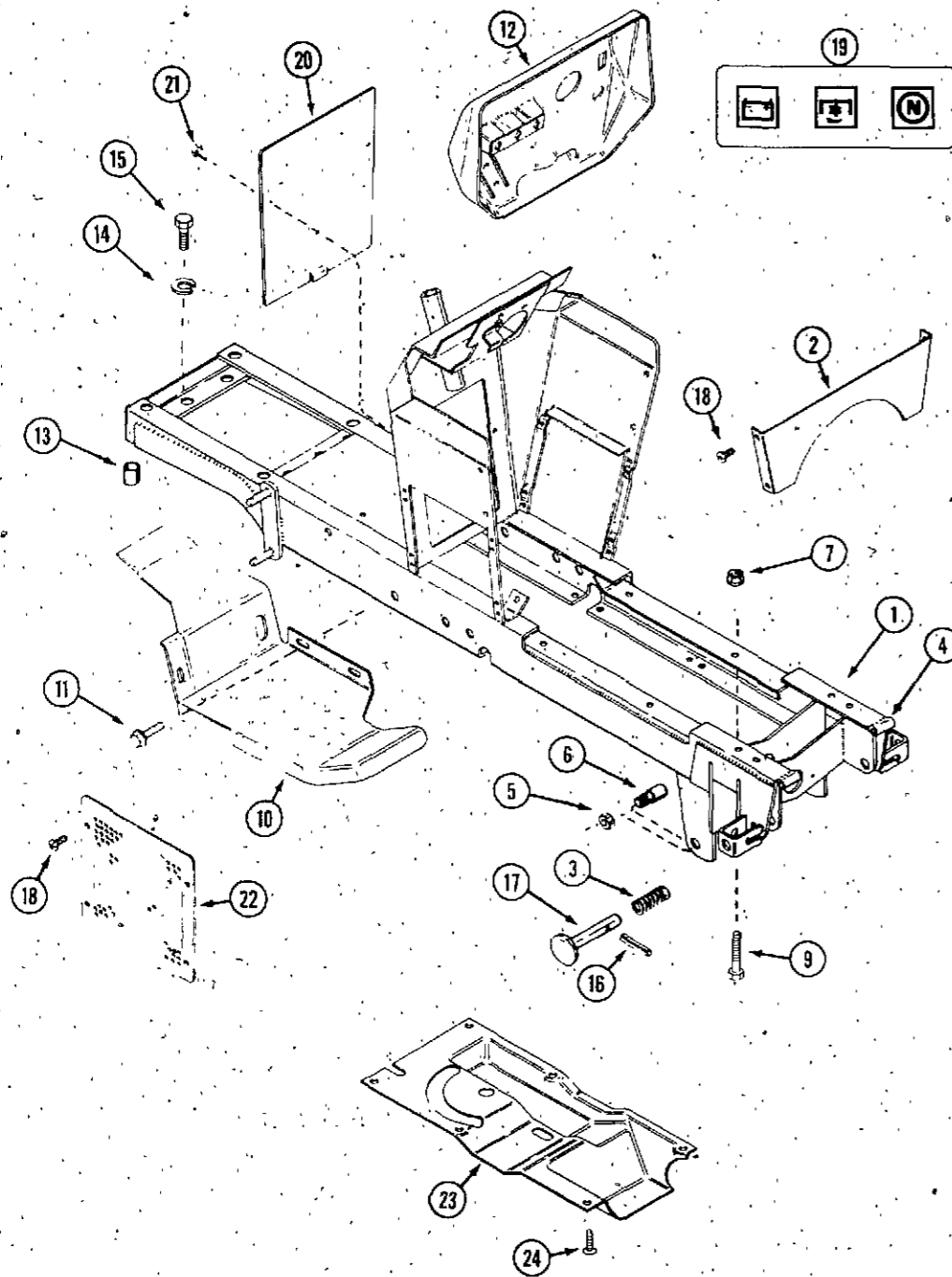

REF.	PART NO.	DESCRIPTION	REQ'D
1	C 33512	FRAME - main (3016PS, 3018PS, 3020PS)	1
1	C 34168	FRAME - main (4016) shown	1
1	C 33514	FRAME - main (4016PS, 4018PS, 4020PS)	1
2	C 31610	SHIELD - oil tank	1
3	C 24137	SPRING - latch	1
4	C 22023	HINGE - frame	2
5	131- 1318	NUT - lock 1/2" N.F.	2
6	C 27508	PIN - attachment	2
7	131- 1352	NUT - lock 3/8" N.C. flange	4
9	113- 208	BOLT - 3/8" - 16 x 1-1/4"	4
10	C 30458	FOOTREST L.H. (3016PS, 3018PS, 3020PS)	1
10	C 30460	FOOTREST R.H. (3016PS, 3018PS, 3020PS) shown	1
10	C 30462	FOOTREST L.H. (4016, 4016PS, 4018PS, 4020PS)	1
10	C 30464	FOOTREST R.H. (4016, 4016PS, 4018PS, 4020PS)	1
11	121- 106	BOLT - 5/16" x 1/2" N.C. flange lock	4
12	C 31368	CAP - instrument panel (4016) shown	4
12	C 33488	CAP - instrument panel (3016PS, 3018PS, 3020PS, 4016PS, 4018PS, 4020PS)	1
13	C 14730	SPACER - rear, frame (3016PS, 3018PS, 3020PS)	2
14	192- 23	LOCKWASHER - 1/2"	4
15	113- 424	BOLT - 1/2" - 13 x 1" transaxle mounting	UAR
15	166- 85	BOLT - 1/2" x 1", 12 pt. flange	UAR
16	138- 2073	PIN - roll 3/16" x 1-1/4"	2
17	C 16373	PIN - latch	2
18	C 31597	SCREW - 1/4" - 20 x 1/2" black	4
18	C 33576	SCREW - 1/4" - 20 x 5/16" black	8
19	C 30274	LENS - display	1
20	C 31359	COVER - access (4016) shown	1
20	C 33548	COVER - access (3016PS, 3018PS, 3020PS, 4016PS, 4018PS, 4020PS)	1
21	187- 1036	SCREW - 1/4" - 20 x 1/2" self tap (4016)	2
21	C 33576	SCREW - 1/4" - 20 x 5/16" black (3016PS, 3018PS, 3020PS, 4016PS, 4018PS, 4020PS)	3
22	C 31967	SCREEN - tower side	2
23	C 31369	PAN - belly (4016) shown	1
23	C 33580	PAN - belly (3016PS, 3018PS, 3020PS, 4016PS, 4018PS, 4020PS)	1
24	C 35067	RETAINER - belly pan 1"	6
24	NSS	RETAINER - belly pan short (use C35067 cut to length)	1

FRAME, FOOT PADS AND BELLY PAN

3018PS - PIN 14181900 and after
 4020PS - PIN 14184000 and after

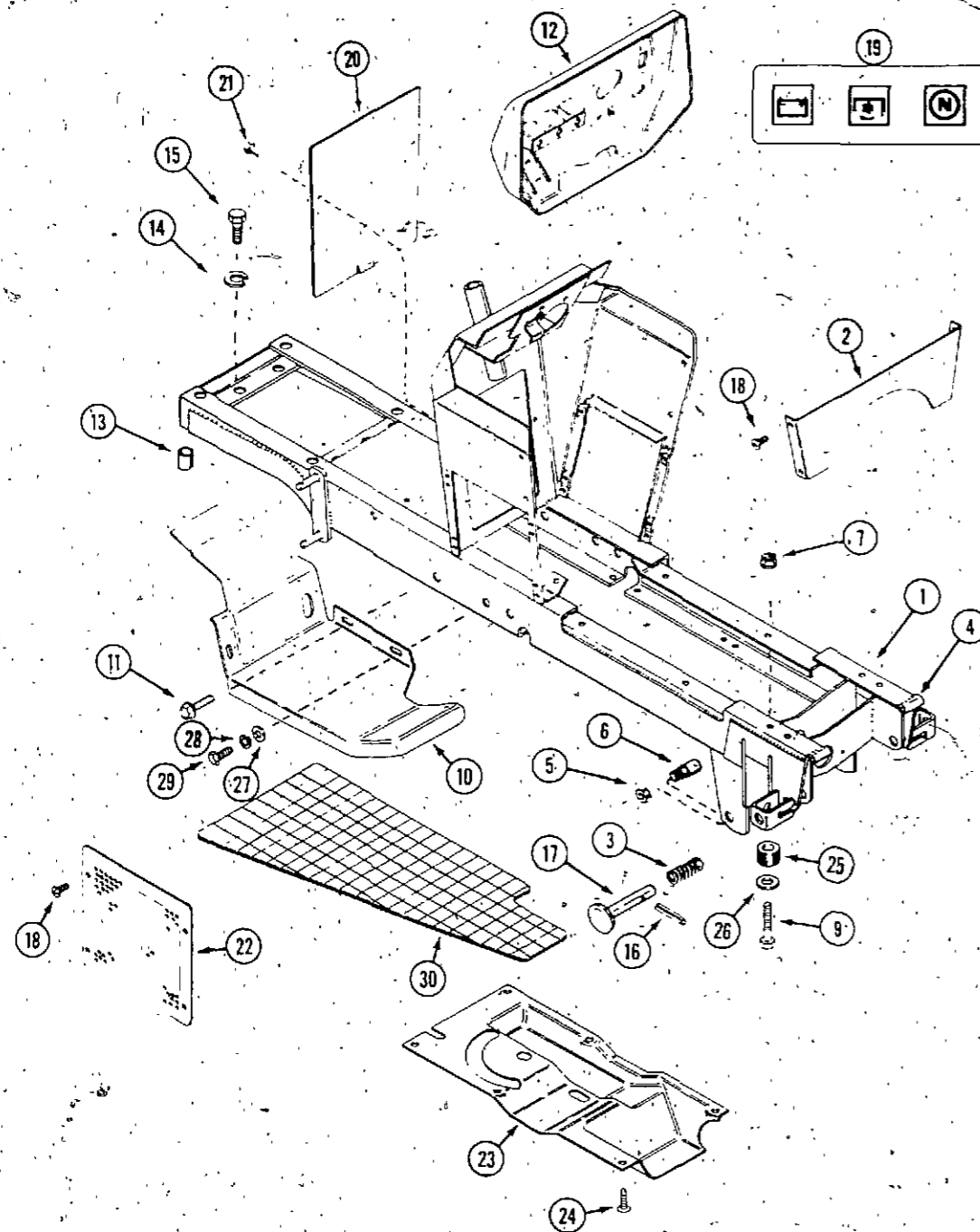

REF.	PART NO.	DESCRIPTION	REQ'D
1	C 44830	FRAME - main (3018PS)	1
1	C 44831	FRAME - main (4020PS)	1
2	C 31610	SHIELD - oil tank	1
3	C 24137	SPRING - latch	1
4	C 22023	HINGE - frame	2
5	131- 1318	NUT - lock 1/2" N.F.	2
6	C 27508	PIN - attachment	2
7	131- 1352	NUT - lock 3/8" N.C. flange	4
9	113- 233	BOLT - 3/8" - 16 x 1-3/4"	4
10	C 37132	FOOTREST L.H. (3018PS)	1
10	C 37134	FOOTREST R.H. (3018PS) shown	1
10	C 37136	FOOTREST L.H. (4020PS)	1
10	C 37138	FOOTREST R.H. (4020PS)	1
11	121- 106	BOLT - 5/16" x 1/2" N.C. flange lock	4
12	C 37167	CAP - instrument panel	1
13	C 14730	SPACER - rear, frame	2
14	192- 23	LOCKWASHER - 1/2"	4
15	113- 424	BOLT - 1/2" - 13 x 1" transaxle mounting	UAR
15	166- 85	BOLT - 1/2" x 1", 12 pt. flange	UAR
16	138- 2073	PIN - roll 3/16" x 1-1/4"	2
17	C 16373	PIN - latch	2
18	C 31597	SCREW - 1/4" - 20 x 1/2" black	4
18	C 33576	SCREW - 1/4" - 20 x 5/16" black	8
19	C 30274	LENS - display	1
20	C 33548	COVER - access	1
21	C 33576	SCREW - 1/4" - 20 x 5/16" black	3
22	C 31967	SCREEN - tower side	2
23	C 33580	PAN - belly	1
24	C 35067	RETAINER - belly pan 1"	5
24	NSS	RETAINER - belly pan 3/8" (use C35067 cut to length)	1
25	C 45049	CUSHION - L.H.	2
25	C 15410	CUSHION - R.H.	2
26	C 45050	WASHER - L.H.	2
26	195- 2029	WASHER - R.H.	2
27	195- 520	WASHER - 5/16"	2
28	192- 20	LOCKWASHER - 5/16"	2
29	113- 101	BOLT - 5/16" - 18 x 1/2"	2
30	C 37140	PAD - footrest L.H.	1
30	C 37141	PAD - footrest R.H. (shown)	1

HOOD AND GRILLE

REF.	PART NO.	DESCRIPTION	REQ'D
1	C 31353	HOOD	1
	C 37312	HINGE - hood (not shown) is welded to hood	1
2	C 16362	ROD - hood hinge	1
3	132- 334	PIN - cotter 1/8" x 3/4"	1
4	C 29314	BUTTON - push, hood release	1
5	C 30126	ROD - push, hood release	1
6	C 30004	SPRING - release	1
7	C 33467	LATCH - hood	1
8	C 31611	BRACKET - hood stop	2
9	121- 106	BOLT - 5/16" - 18 x 1/2" flange lock	4
10	C 45043	GRILLE	1
11	131- 934	NUT - 1/4" - 20 flange lock	2
12	C 31597	SCREW - 1/4" - 20 x 1/2" black	2
13	187- 1328	SCREW - #8 - 18 x 3/8"	1
14	C 31366	SHROUD - headlight	1
15	C 31612	SHIELD - heat	1

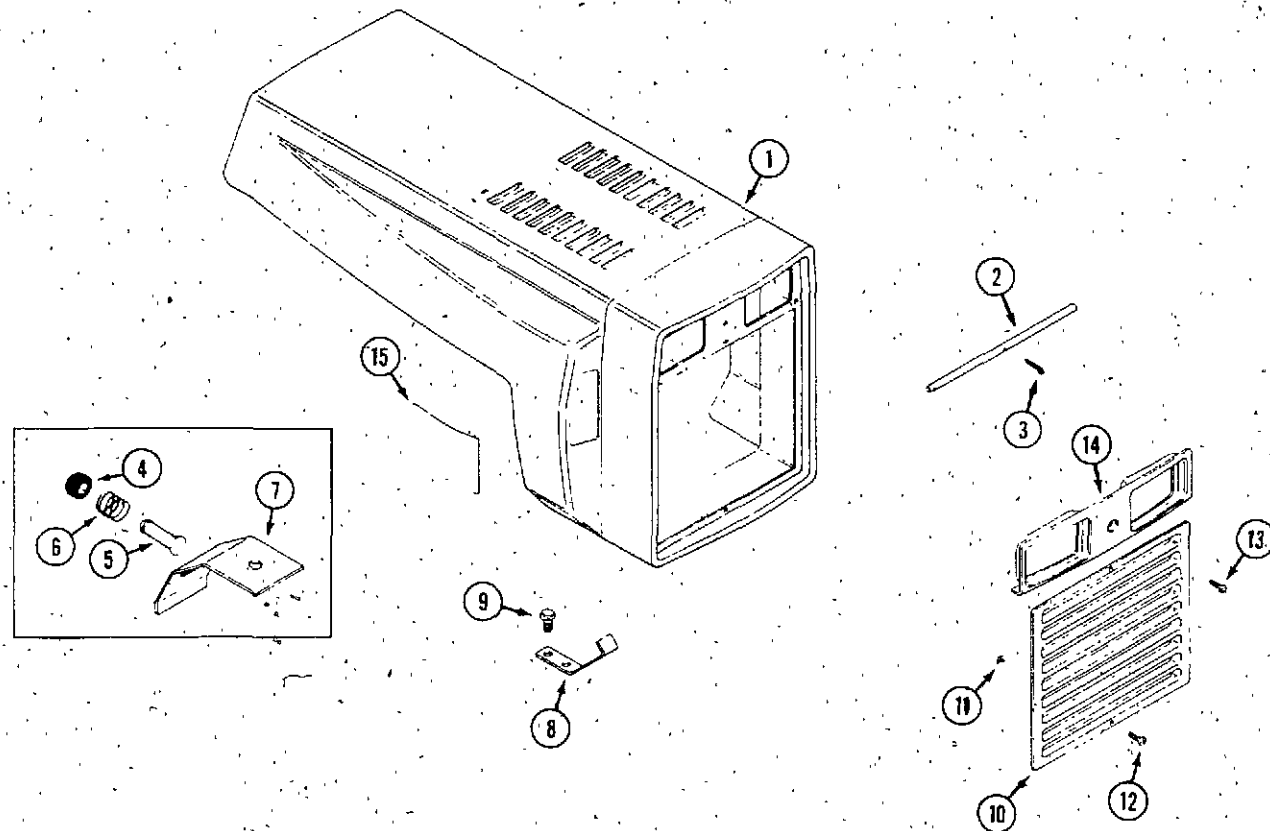

SEAT, FENDERS AND TOOL TRAY

3016PS, 3020PS, 4016, 4016PS, 4018PS - All.
 3018PS - before PIN 14181900
 4020PS - before PIN 14184000

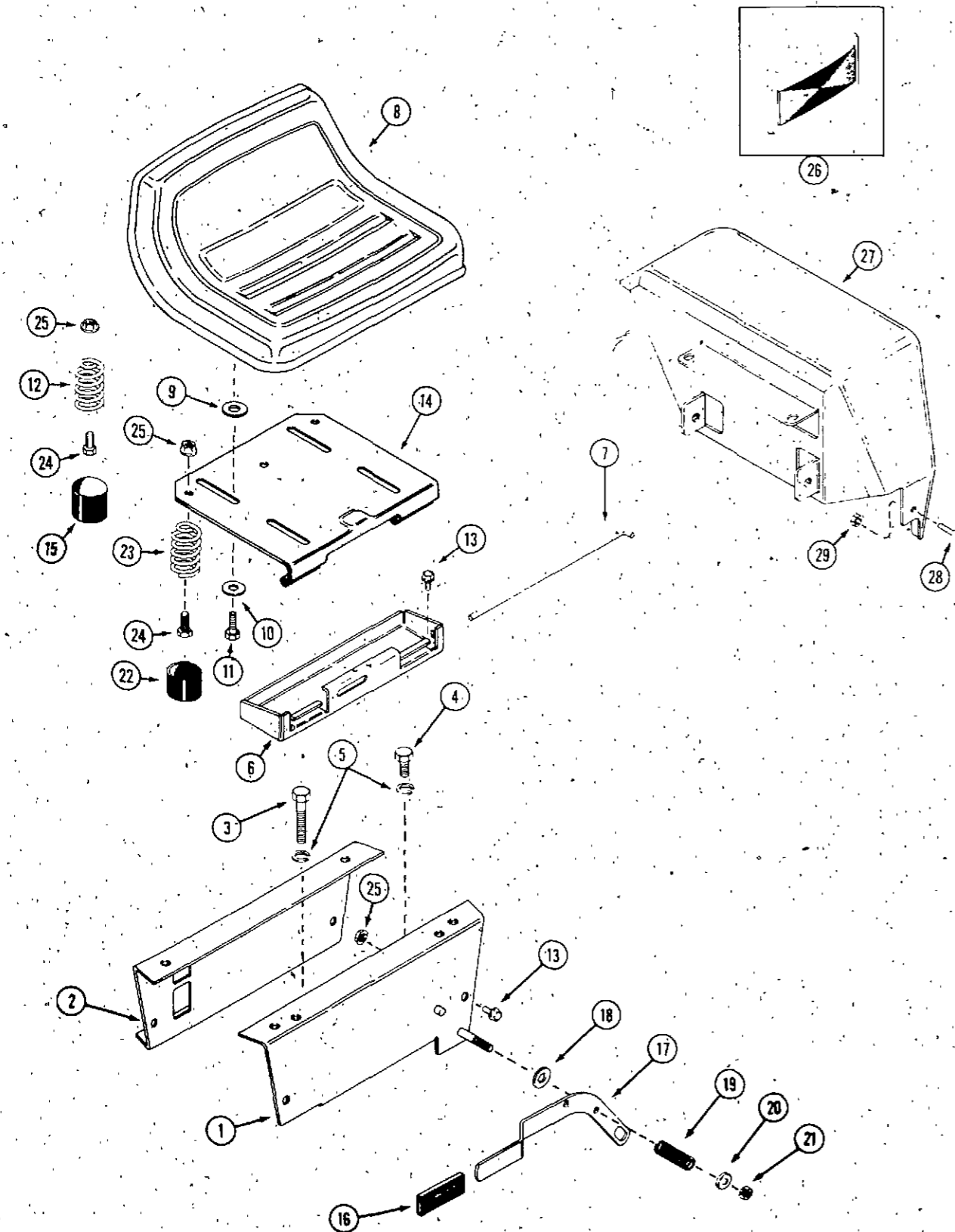

REF.	PART NO.	DESCRIPTION	REQ'D
1	C 31020	SUPPORT - seat, front shown (3016PS, 3018PS, 3020PS)	1
1	C 31021	SUPPORT - seat, front (4016, 4016PS, 4018PS, 4020PS)	1
2	C 26827	SUPPORT - seat, rear (3016PS, 3018PS, 3020PS)	1
2	C 27224	SUPPORT - seat, rear (4016, 4016PS, 4018PS, 4020PS)	1
3	113- 427	BOLT - 1/2" x 3-1/4" (3016PS, 3018PS, 3020PS)	2
3	113- 441	BOLT - 1/2" - 2-1/4" N.C. hex (4016, 4016PS, 4018PS, 4020PS)	2
4	113- 424	BOLT - 1/2" x 1" N.C. hex	1
4	113- 118	BOLT - 5/16" x 5/8"	1
5	192- 20	LOCKWASHER - 5/16"	1
5	192- 23	LOCKWASHER - 1/2"	4
6	C 31004	TRAY - tool	1
7	C 16429	PIN - seat hinge	1
8	C 30071	SEAT - shown (black) (3016PS, 3018PS, 3020PS)	1
8	C 30066	SEAT - black (4016, 4016PS, 4018PS, 4020PS)	1
9	C 29812	WASHER - special	4
10	195- 2175	WASHER - 5/16" x 1-1/4" OD, zinc	4
11	113- 102	BOLT - 5/16" x 3/4"	4
12	C 31006	SPRING - seat switch	1
13	121- 106	BOLT - 5/16" x 1/2" flange lock	10
14	C 33474	HINGE ASSEMBLY - seat	1
15	C 26526	CAP - spring	1
16	C 14728	GRIP - shift lever	1
17	C 27594	LEVER - shift	1
18	195- 525	WASHER - 7/16"	1
19	C 17216	SPRING - shift lever	1
20	C 30489	WASHER	1
21	131- 1216	NUT - lock 3/8" N.C. hex	1
22	C 29305	CAP - spring	2
23	C 29306	SPRING - seat	2
24	113- 102	BOLT - 5/16" - 18 x 3/4"	3
25	131- .911	NUT - 5/16" - 18 flange lock	7
26	C 30942	REFLECTOR - red, rear fender	2
27	C 32386	FENDER - R.H. (3016PS, 3018PS, 3020PS)	1
27	C 32385	FENDER - L.H. shown (3016PS, 3018PS, 3020PS)	1
27	C 32388	FENDER - R.H. (4016, 4016PS, 4018PS, 4020PS)	1
27	C 32387	FENDER - L.H. (4016, 4016PS, 4018PS, 4020PS)	1
28	182- 547	SCREW - 1/4" - 20 x 1/2"	2
29	131- 934	NUT - 1/4"	2

SEAT, FENDER AND TOOL TRAY

Use PIN and AFTER:
 3018PS - use PIN 14181900 and after
 4020PS - use Pin 14184000 and after

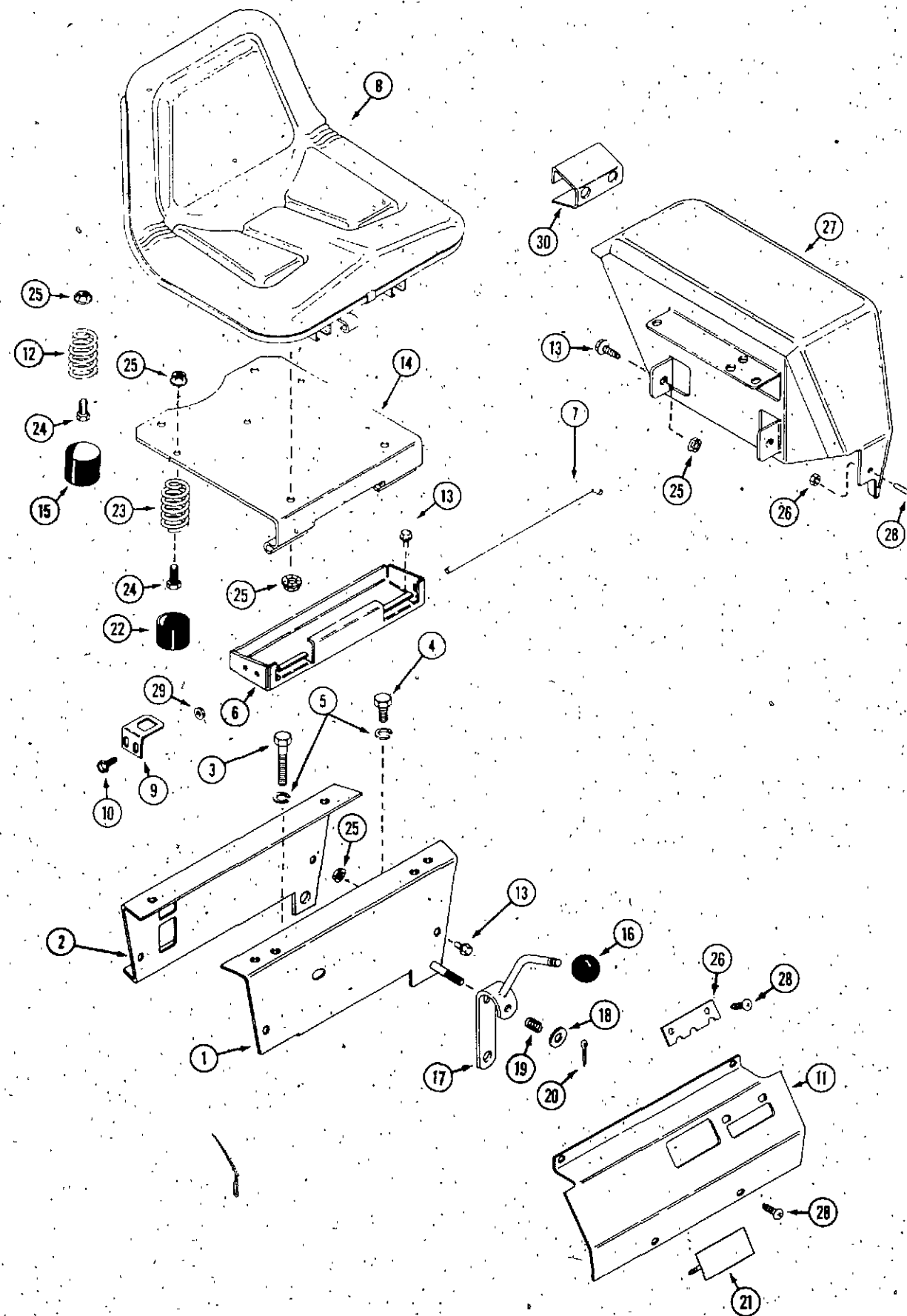

REF.	PART NO.	DESCRIPTION	REQ'D
1	C 44925	SUPPORT - seat, front (3018PS)	1
1	C 44926	SUPPORT - seat, front (4020PS)	1
2	C 37266	SUPPORT - seat, rear (4020PS)	1
2	C 37265	SUPPORT - seat, rear (3018PS)	2
3	113- 427	BOLT - 1/2" x 3-1/4" (3018PS)	2
3	113- 441	BOLT - 1/2" x 2-1/4" (4020PS)	2
4	113- 424	BOLT - 1/2" x 1" N.C. hex	1
4	113- 118	BOLT - 5/16" x 5/8"	1
5	192- 20	LOCKWASHER - 5/16"	1
5	192- 23	LOCKWASHER - 1/2"	4
6	C 37017	TRAY - tool	1
7	C 16429	PIN - seat hinge	1
8	C 37151	SEAT - operator's	1
9	C 37299	BRACKET - switch mounting	1
10	113- 2	BOLT - 1/4" - 20 x 5/8"	2
11	C 44929	COVER - shift lever (3018PS)	1
11	C 44930	COVER - shift lever (4020PS)	1
12	C 37462	SPRING - seat switch	1
13	121- 106	BOLT - 5/16" x 1/2" flange lock	10
14	C 37152	HINGE ASSEMBLY - seat	1
15	C 26526	CAP - spring	1
16	C 10487	KNOB - shift lever	1
17	C 44931	LEVER - shift (3018PS)	1
17	C 44932	LEVER - shift (4020PS)	1
18	195- 525	WASHER - 7/16"	1
19	C 10482	SPRING - shift lever	1
20	132- 310	PIN - cotter 1/8" x 1"	1
21	C 37460	COVER - plate	1
22	C 29305	CAP - spring	2
23	C 29306	SPRING - seat	2
24	113- 102	BOLT - 5/16" - 18 x 3/4"	3
25	131- 911	NUT - 5/16" - 18 flange lock	11
26	C 37428	PLATE - shift pattern (shown) (3018PS)	1
26	C 37430	PLATE - shift patten (4020PS)	1
27	C 37154	FENDER - R.H. (3018PS)	1
27	C 37153	FENDER - L.H. shown (3018PS)	1
27	C 37156	FENDER - R.H. (4020PS)	1
27	C 37155	FENDER - L.H. (4020PS)	1
28	C 31597	SCREW - 1/4" - 20 x 1/2"	6
29	131- 934	NUT - 1/4"	6
30	C 42155	PROTECTOR - tail light	2

MANUAL STEERING (4016)

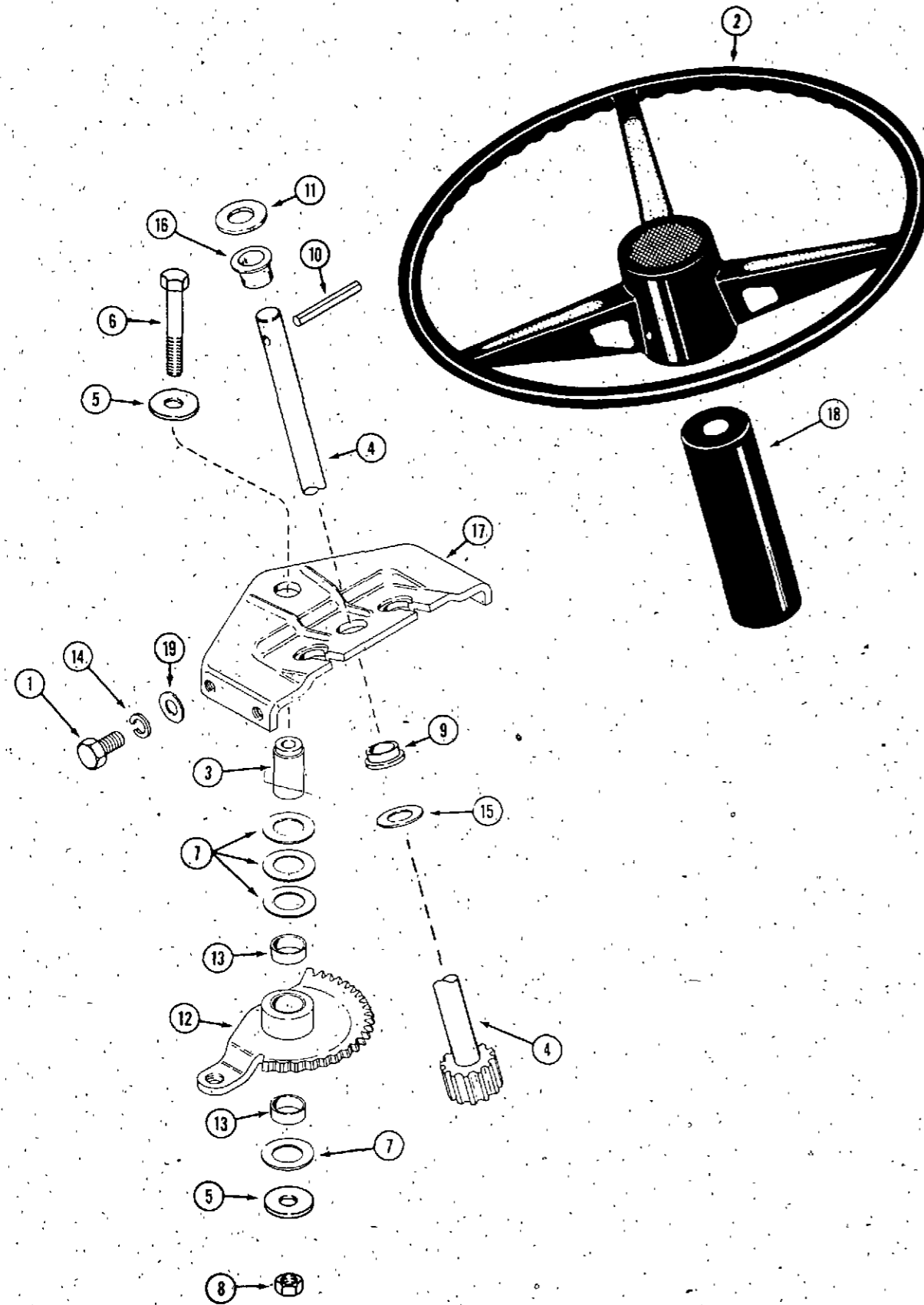

REF.	PART NO.	DESCRIPTION	REQ'D
1	113- 206	BOLT - 3/8" x 3/4" N.C. hex	4
2	C 26325	WHEEL - steering	1
3	C 29044	PIN - pivot	1
4	C 33940	SHAFT - steering	1
5	C 29812	WASHER - 3/8" x 1.4"	2
6	113- 241	BOLT - 3/8" - 16 x 3"	1
7	C 14201	WASHER - shim	4
8	131- 1352	NUT - 3/8" - 16 hex lock (tighten to a torque of 45 ft. lbs.)	1
9	C 27501	BUSHING	1
10	138- 143	PIN - roll 1/4" - 2-1/4"	1
11	195- 541	WASHER - 5/8"	UAR
11	195- 2206	WASHER - shim .060"	UAR
12	C 33309	GEAR - steering	1
13	C 33308	BUSHING - sleeve	2
14	192- 21	LOCKWASHER - 3/8"	4
15	195- 2069	WASHER - 5/8" zinc plated	1
16	C 15096	BUSHING - flanged nylon	1
17	C 44378	SUPPORT - steering gear (includes item 9)	1
18	C 33945	TUBE - steering	1
19	195- 103	WASHER - 3/8"	2

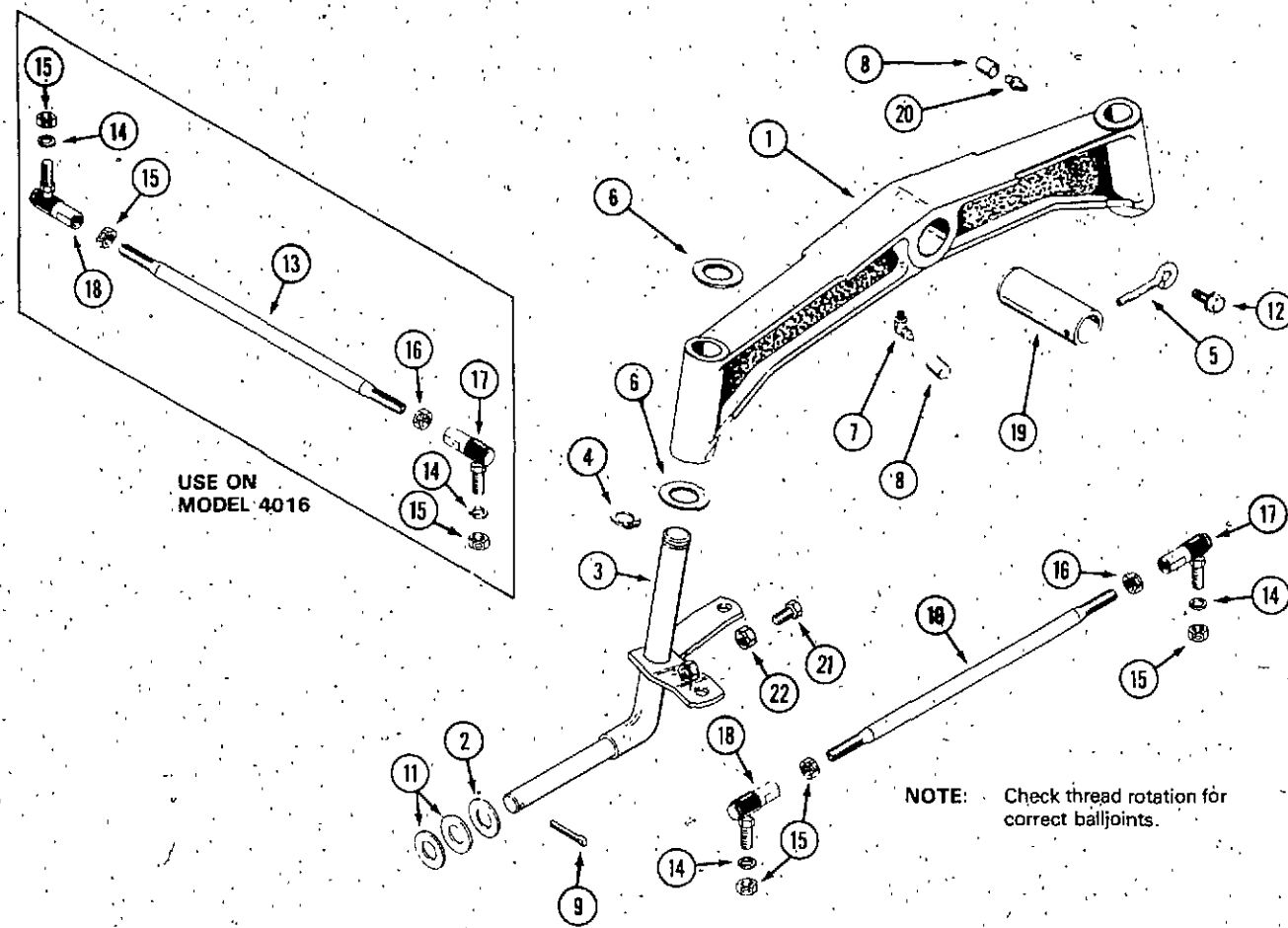

FRONT AXLE

REF.	PART NO.	DESCRIPTION	REQ'D
1	C 18812	AXLE - front (3016PS, 3018PS, 3020PS)	1
1	C 40687	AXLE - front shown (4016, 4016PS, 4018PS, 4020PS)	1
2	195- 545	WASHER - spacer	2
3	C 45088	SPINDLE - R.H. (3016PS, 3018PS, 3020PS)	1
3	C 31341	SPINDLE - R.H. shown (4016)	1
3	C 45086	SPINDLE - L.H. (3016PS, 3018PS, 3020PS)	1
3	C 31340*	SPINDLE - L.H. (4016, 4016PS, 4018PS, 4020PS)	1
3	C 33537*	SPINDLE - R.H. (4016PS, 4018PS, 4020PS)	1
3	C 40690**	SPINDLE - L.H. (4020PS)	1
3	C 40688**	SPINDLE - R.H. (4020PS) shown	1
4	C 27902	RING - retaining, spindle (4016, 4016PS, 4018PS, 4020PS)	2
4	C 28232	RING - retaining, spindle (3016PS, 3018PS, 3020PS)	2
5	C 22278	PIN - retaining, axle pivot	1
6	C 11906	WASHER - thrust (3016PS, 3018PS, 3020PS)	4
6	C 13716	WASHER - thrust (4016, 4016PS, 4018PS, 4020PS)	4
7	219- 404	FITTING - lubrication	3
8	C 13106	COVER - lubrication fitting	3
9	132- 311	PIN - cotter 5/32" x 1-1/4"	2
10	C 25855	TIE ROD - (4016, 4016PS, 4018PS, 4020PS)	1
10	C 25856	TIE ROD - (3016PS, 3018PS, 3020PS)	1
11	C 28226	WASHER - wheel spacer	UAR
12	187- 1910	BOLT - 3/8" - 16 x 3/4" N.C. hex head	1
13	C 44806	LINK - drag (4016)	1
14	192- 23	LOCKWASHER - 1/2" zinc	4
15	129- 165	NUT - 1/2" N.F. R.H. thread, lock	6
16	129- 365	NUT - 1/2" N.F. L.H. thread, lock	2
17	C 44641	BALL JOINT - 1/2" L.H. thread	2
18	C 44640	BALL JOINT - 1/2" R.H. thread	2
19	C 22568	PIN - axle pivot	1
20	219- 17	FITTING - lubrication	2
21	113- 208	BOLT - 3/8" - 16 x 1-1/4"	2
22	129- 103	NUT - 3/8" - 16	2

*Use before PIN:
 **Use PIN and after:
 4020 PS - 14180301
 All Other models are before PIN

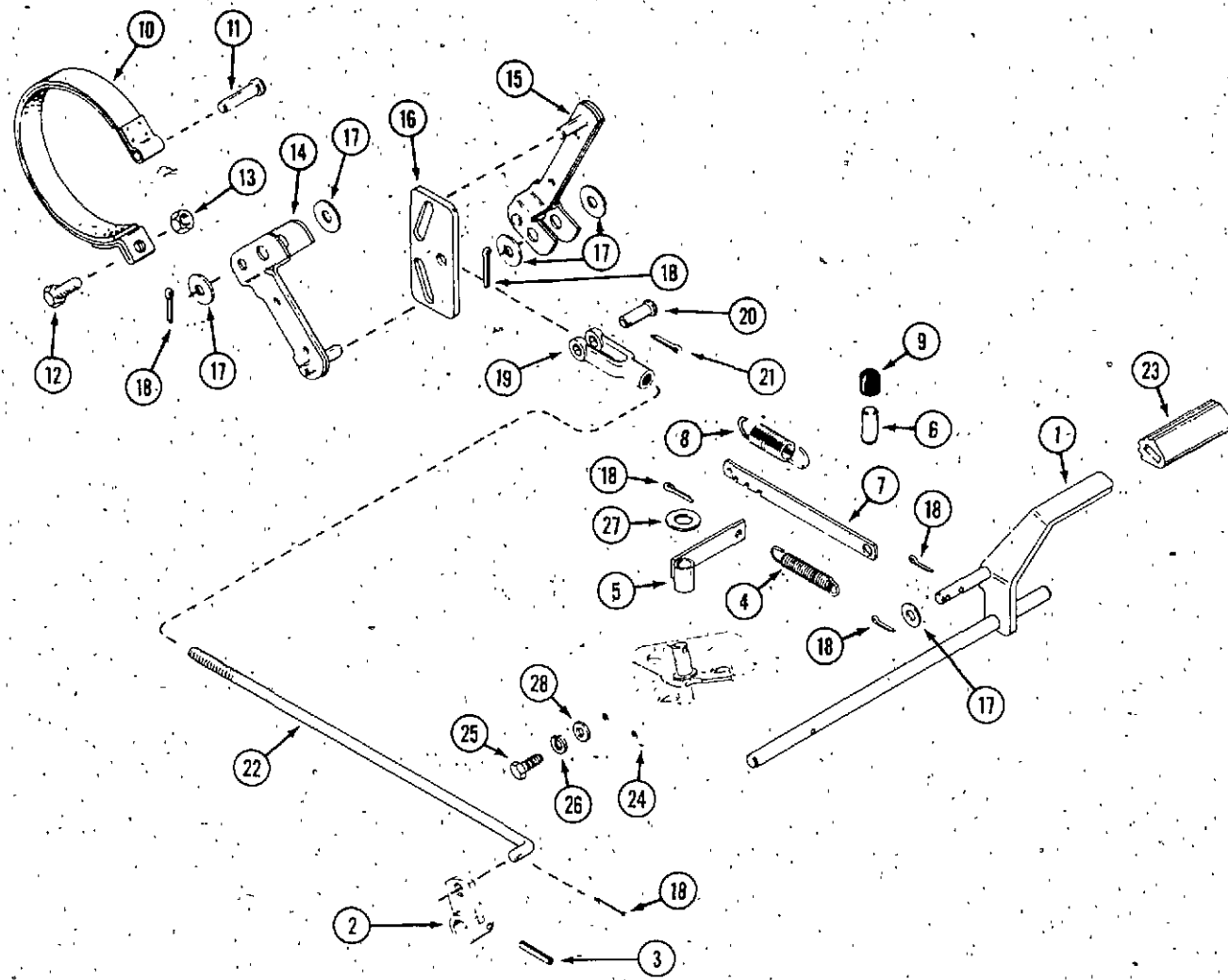

BRAKE ASSEMBLY

REF.	PART NO.	DESCRIPTION	REQ'D
1	C 33942	PEDAL - brake actuating	1
2	C 26381	ARM - brake pedal	1
3	138- 2073	PIN - roll 3/16" x 1-1/4"	1
4	C 31660	SPRING - return	1
5	C 31662	GUIDE - neutral return (shown) 4016	1
5	C 33759	GUIDE - neutral return (3016PS, 3018PS, 3020PS, 4016PS, 4018PS, 4020PS)	1
6	C 31604	ACTUATOR - parking brake	1
7	C 31661	LEVER - brake lock	1
8	C 21942	SPRING - brake lock	1
9	C 31605	CAP - actuator	1
10	C 33427	BAND - brake	1
11	C 23910	PIN - clevis	1
12	113- 2262	BOLT - 3/8" - 16 x 1-1/2" hex	1
13	129- 143	NUT - 3/8" - 16 special	1
14	C 23899	ARM - brake	1
15	C 24761	ARM - brake (includes adjustment nut)	1
16	C 40646	GUIDE - brake actuator	1
17	195- 533	WASHER - .531" I.D.	5
18	132- 310	PIN - cotter 1/8" x 1"	5
19	C 28978	CLEVIS	1
20	141- 4	PIN - clevis	1
21	132- 321	PIN - cotter	1
22	C 31993	ROD - brake (4016, 4016PS, 4018PS, 4020PS)	1
22	C 31992	ROD - brake (3016PS, 3018PS, 3020PS)	1
23	C 31975	PAD - brake pedal	1
24	C 44380	BRACKET - support (3016PS, 3018PS, 3020PS, 4016PS, 4018PS, 4020PS)	1
25	113- 206	BOLT - 3/8" - 16 x 3/4"	4
26	192- 21	LOCKWASHER - 3/8"	4
27	195- 2063	WASHER	1
28	195- 103	WASHER - 3/8"	2

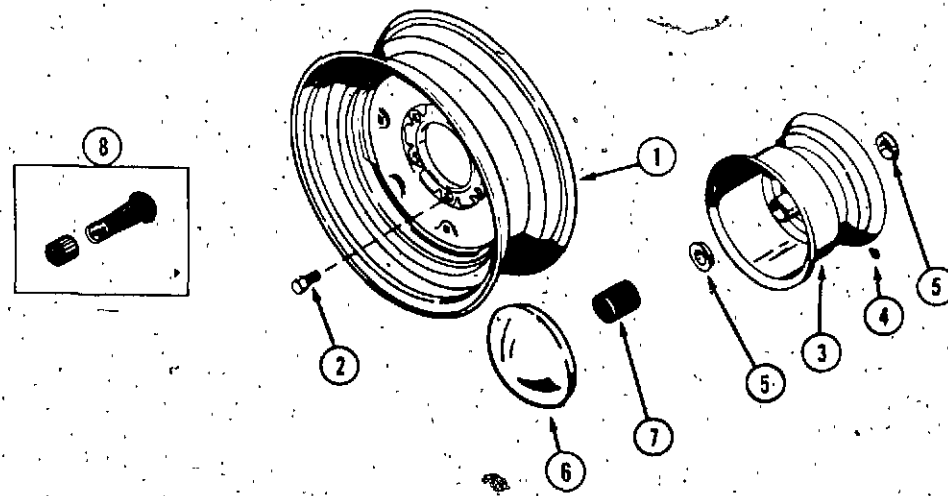

FRONT AND REAR WHEELS

1	C 30913	WHEEL - rear, 5 bolt (3016PS, 3018PS, 3020PS) for 23 x 8.50 - 12 tire	2
1	C 30917	WHEEL - rear, 6 bolt (4016, 4016PS, 4018PS, 4020PS) shown	2
1	C 30922	WHEEL - rear, 5 bolt (3016PS, 3018PS, 3020PS) for 23 X 10.50 - 12 tire	2
2	C 27763	BOLT - rear wheel (4016, 4016PS, 4018PS, 4020PS)	12
2	C 10314	BOLT - rear wheel (3016PS, 3018PS, 3020PS)	10
3	C 30912	WHEEL - front (includes bearings)	2
4	219- 403	FITTING - lubrication	2
5	C 44499	BEARING - wheel	2
6	C 28965	CAP - hub, front wheel (optional)	2
7	C 44478	CAP - plastic, front	2
8	C 28236	STEM - valve	4
	C 13106	COVER - lubrication fitting	2

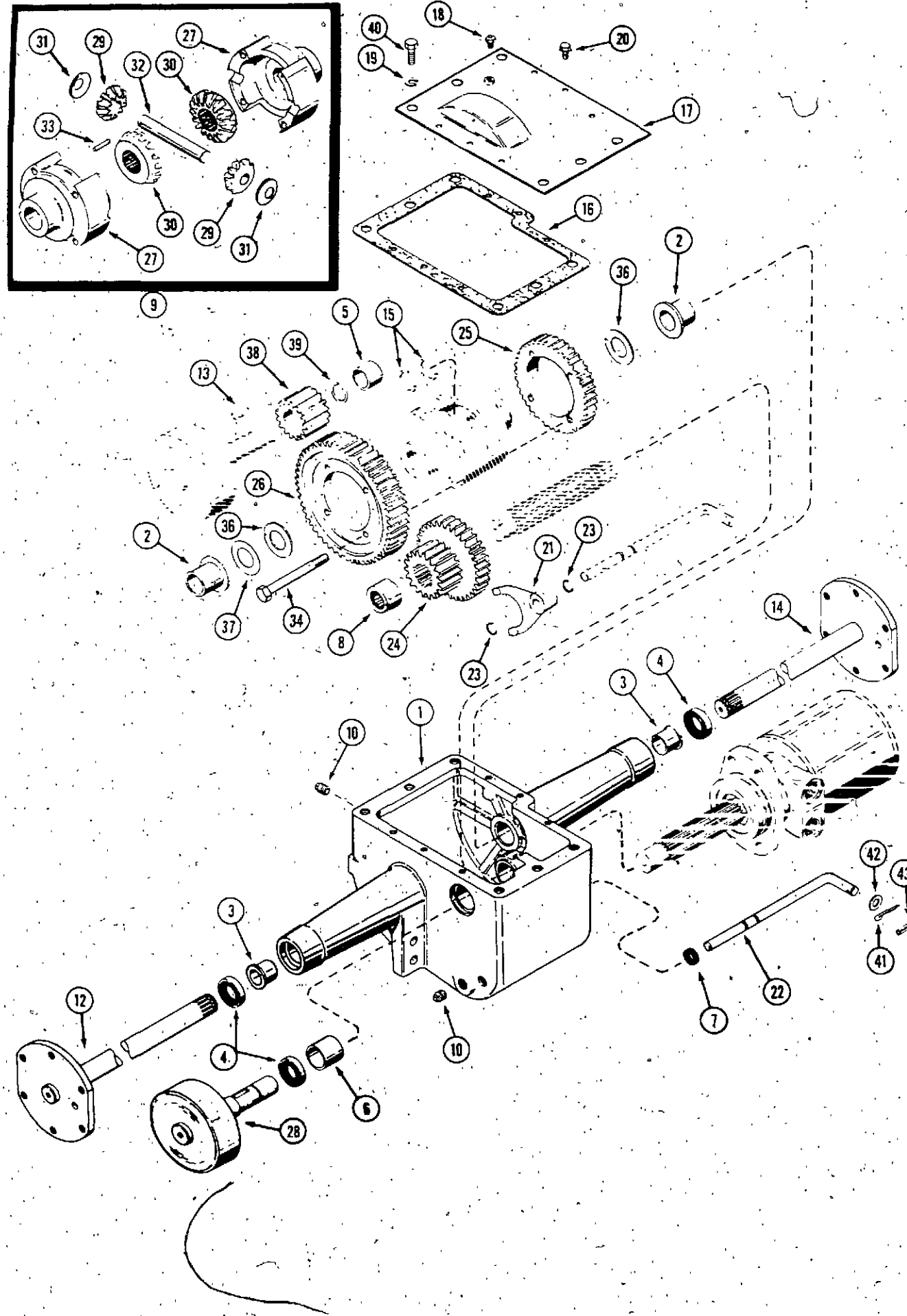

TRANSMISSION AND FINAL DRIVE

REF.	PART NO.	DESCRIPTION	REQ'D
1	C 23843	CASE ASSEMBLY - transmission (includes bearings & seals only)	1
	NSS	CASE - transmission (order C24843)	1
2	C 12713	BEARING - flange	2
3	C 24804	BEARING - flange	2
4	C 24803	SEAL - shaft	3
5	C 13241	BEARING - sleeve	1
6	C 13385	BEARING - sleeve	1
7	C 13266	SEAL - shift rod	1
8	C 28281	BEARING - roller	1
9	C 30029*	DIFFERENTIAL ASSEMBLY (also includes C30030, C30031, C12552)	1
9	C 36902**	DIFFERENTIAL ASSEMBLY (also includes C36903, C30031, C12552)	1
10	221- 3	PLUG - filler and drain 3/8"	3
12	C 16699	SHAFT - axle, short R.H. (3016PS, 3018PS, 3020PS)	1
12	C 22638	SHAFT - axle, short R.H.-shown (4016, 4016PS, 4018PS, 4020PS)	1
13	126- 128	KEY - Woodruff, brake idler #18, 1/4" x 1-1/8"	1
14	C 16700	SHAFT - axle, long L.H. (3016PS, 3018PS, 3020PS)	1
14	C 22637	SHAFT - axle, long L.H.-shown (4016, 4016PS, 4018PS, 4020PS)	1
15	C 26342	RING - retainer, axle	2
16	C 13196	GASKET - transmission cover	1
17	C 36935	COVER - transmission	1
18	C 28241	BREATHER - transmission	1
19	192- 23	LOCKWASHER - 1/2"	4
20	121- 21	BOLT - 1/4" x 1/2" N.C. hex lock	6
21	C 12725	FORK - shift	1
22	C 37222	ROD - gear shift	1
23	C 14168	RING - retaining	2
24	C 14644*	GEAR - cluster input	1
24	C 36901**	GEAR - cluster input	UAR
25	C 30030*	GEAR - high 41 tooth	1
25	C 36903**	GEAR - high range	1
26	C 12552	GEAR - low 55 tooth	1
27	NSS	DIFFERENTIAL CASE	1
28	G 33305	BRAKE DRUM	1
29	NSS	GEAR - differential pinion	2
30	NSS	GEAR - differential	2
31	NSS	WASHER - pinion thrust	2
32	NSS	PIN - differential	1
33	NSS	PIN - differential pin lock	1
34	C 30031	KIT - screw (set of four)	1
36	C 12718	WASHER - differential	2
37	C 14223	WASHER - spacer	UAR
38	C 33417	GEAR - brake idler	1
39	C 14222	RING - retainer, brake idler	1
40	113- 424	BOLT - 1/2" - 13 x 1" hex	UAR
40	166- 86	BOLT - 1/2" - 13 x 1-1/4"	UAR
41	132- 310	PIN - cotter 1/8" x 1"	UAR
42	195- 541	WASHER - .656" ID x 1.312 OD	1
43	138- 2073	PIN - spirol 3/16" x 1-1/4"	UAR

*Use before PIN:
 **Use PIN and after:
 3018PS - 14181900
 4020PS - 14184000
 all others before PIN

**HYDRAULIC SYSTEM
4016**

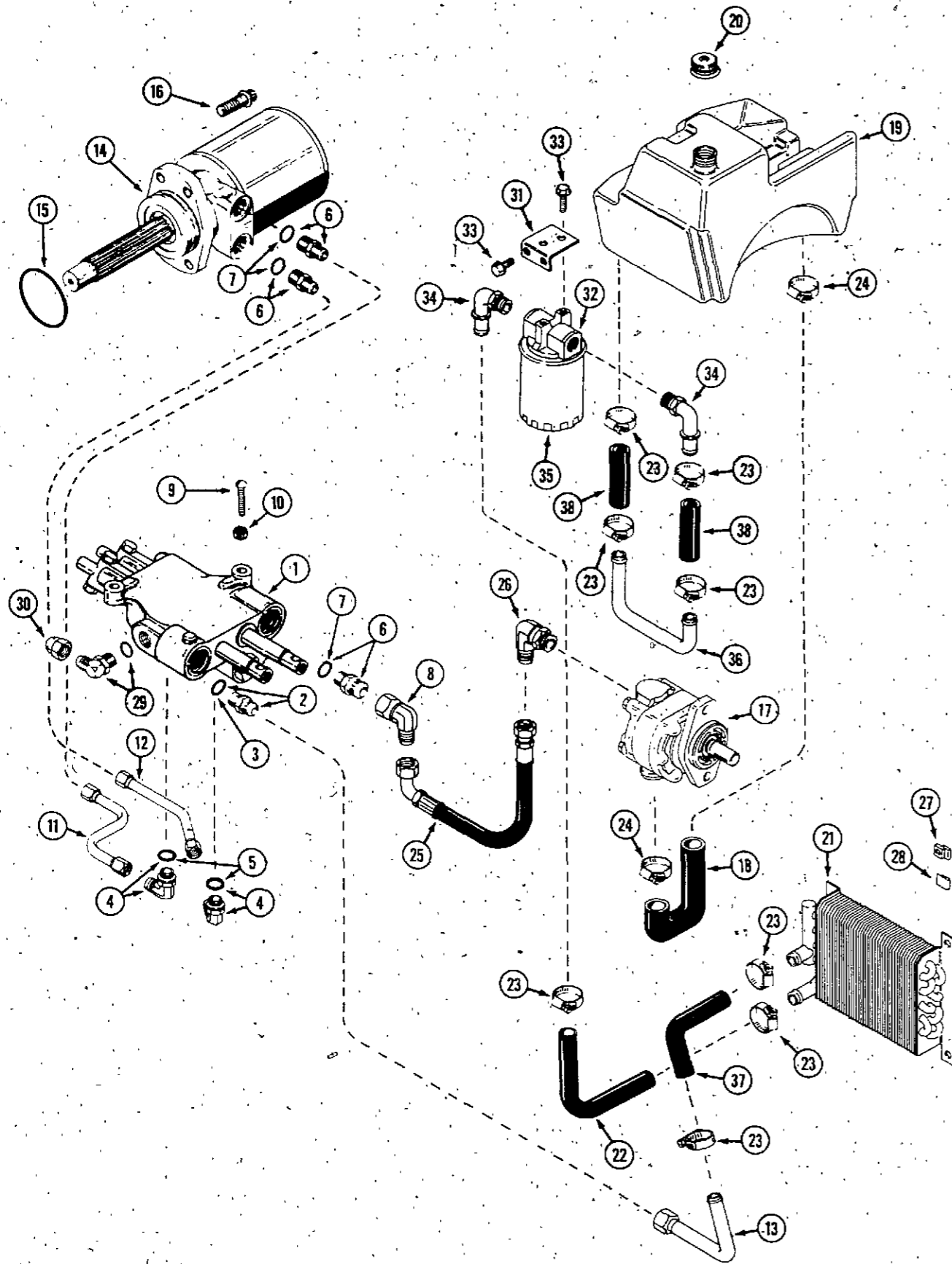

REF.	PART NO.	DESCRIPTION	REQ'D
1	C 33473	VALVE - control (repairs page 57)	1
2	218- 5065	FITTING - 3/4" x 5/8" "O" ring	1
3	218- 5007	"O" RING	1
4	218- 5107	FITTING - 90° elbow	2
5	218- 5007	"O" RING	1
6	218- 5062	FITTING - 5/8" x 7/8" "O" ring	3
7	218- 5007	"O" RING	1
8	218- 5232	FITTING - 90° elbow	1
9	C 27764	SCREW - 5/16" - 18 x 1-1/4" round head	2
10	131- 351	NUT - lock 5/16"	2
11	C 29657	TUBE - valve to upper motor port	1
12	C 29658	TUBE - valve to lower motor port	1
13	C 31435	TUBE - valve "out" to heat exchanger	1
14	C 33234	MOTOR - hydraulic (repairs page 55)	1
15	C 28949	SEAL - motor to transmission	1
16	166- 85	SCREW - 1/2" - 18 x 1" 12 pt. flange	4
17	C 31958	PUMP - hydraulic 1/2" shaft (repairs page 53)	1
18	C 33423	HOSE - pump inlet	1
19	C 33180	RESERVOIR - oil	1
20	C 34175	CAP - reservoir	1
21	C 31295	EXCHANGER - heat	1
22	C 33555	HOSE - formed 90°	1
23	214- 254	CLAMP - hose 1-1/4"	8
24	214- 14	CLAMP - hose 1-3/8"	2
25	C 31966	HOSE - pump to valve	1
26	218- 5117	FITTING - 90° elbow	1
27	C 31973	"J" NUT - 1/4" - 20	4
28	C 31974	"U" Clip - retainer	4
29	C 33559	FITTING - tee, 3/8" tube x 1/2" - 20	1
30	218- 754	CAP - 3/8" tube	1
31	C 33577	BRACKET - oil filter	1
32	C 33446	HEAD - oil filter	1
33	121- 21	BOLT - 1/4" - 20 x 1/2"	4
34	217- 333	FITTING - 90° 3/8" NPTF x 3/4" barb stem	2
35	C 33445	FILTER - oil	1
36	C 33544	TUBE - filter to tank	1
37	C 33556	HOSE - formed 90°	1
38	C 29697	HOSE - 3/4" x 4"	2

UAR

HYDRAULIC SYSTEM

3016PS, 3020PS (3018PS before PIN 14181900)
4016PS, 4018PS, (4020PS before PIN 14184000)

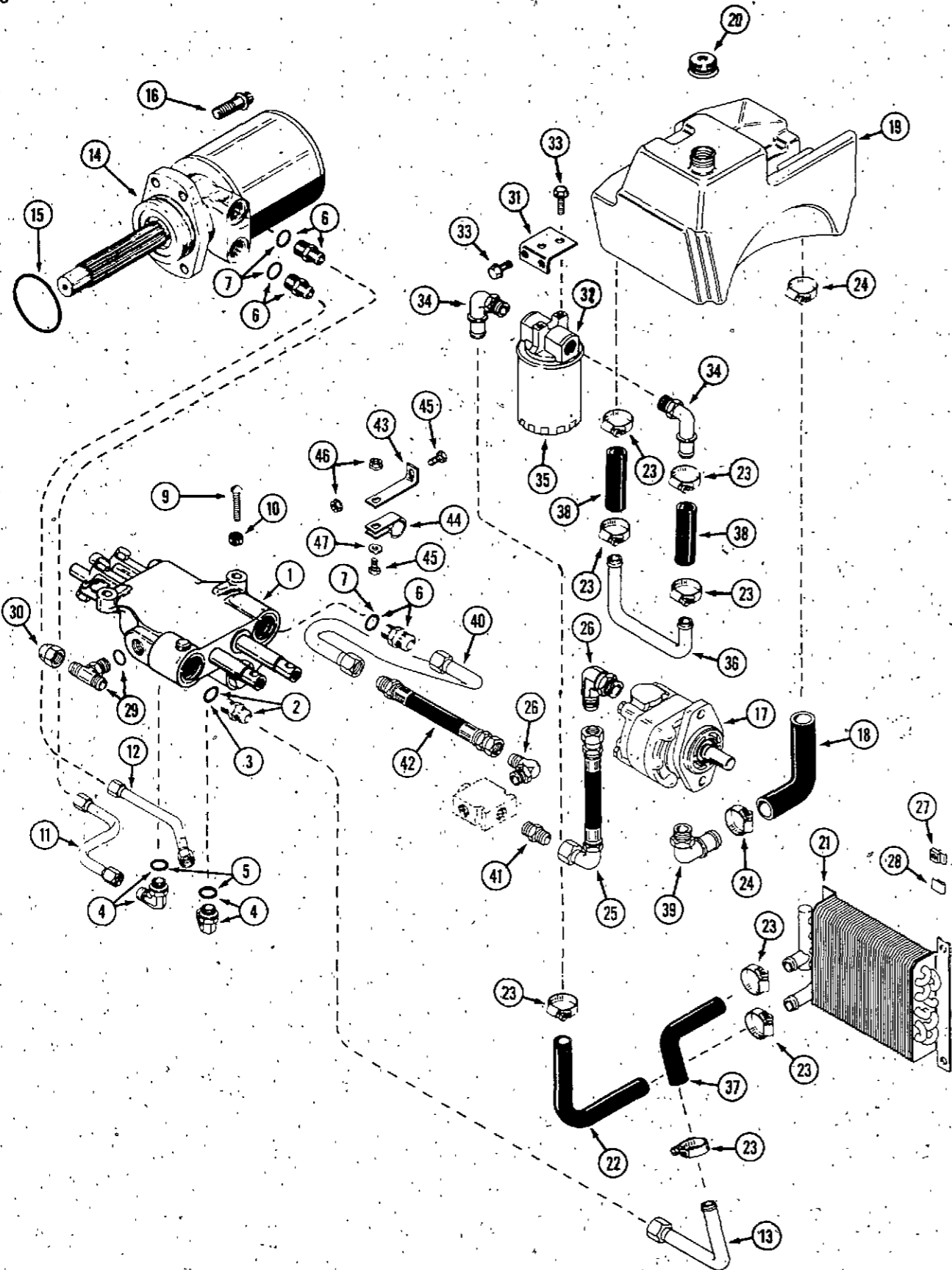

REF.	PART NO.	DESCRIPTION	REQ'D
1	C 33473	VALVE - control (repairs page 57)	1
2	218- 5065	FITTING - 3/4" x 5/8"	1
3	218- 5007	"O" RING	1
4	218- 5107	FITTING - 90° elbow	2
5	218- 5007	"O" RING	1
6	218- 5062	FITTING - 5/8" x 7/8" "O" ring	UAR
7	218- 5007	"O" RING	1
9	C 27764	SCREW - 5/16" - 18 x 1-1/4" round head	2
10	131- 351	NUT - lock 5/16"	2
11	C 29655	TUBE - valve to upper motor port (3016PS, 3018PS, 3020PS)	1
11	C 29657	TUBE - valve to upper motor port (4016PS, 4018PS, 4020PS)	1
12	C 29656	TUBE - valve to lower motor port (3016PS, 3018PS, 3020PS)	1
12	C 29658	TUBE - valve to lower motor port (4016PS, 4018PS, 4020PS)	1
13	C 31435	TUBE - valve "out" to heat exchanger	1
14	C 30939	MOTOR - hydraulic (repairs page 55) (3016PS, 3018PS, 3020PS)	1
14	C 33234	MOTOR - hydraulic (4016PS, 4018PS, 4020PS) (repairs page 55)	1
15	C 28949	SEAL - motor to transmission	1
16	166- 85	SCREW - 1/2" - 13 x 1" 12 pt. flange	4
17	C 33579	PUMP - hydraulic 3/4" shaft (repairs page 53)	1
18	C 33551	HOSE - pump inlet	1
19	C 33180	RESERVOIR - oil	1
20	C 37093	CAP - reservoir	1
21	C 31295	EXCHANGER - heat	1
22	C 33555	HOSE - formed 90°	1
23	214- 254	CLAMP - hose 1-1/4"	8
24	214- 14	CLAMP - hose 1-3/8"	2
25	C 33557	HOSE - pump to regulator	1
26	218- 5117	FITTING - 90° elbow	2
27	C 31973	"J" NUT - 1/4" - 20	4
28	C 31974	"U" Clip - retainer	4
29	C 33559	FITTING - tee, 3/8" tube x 1/2" - 20	UAR
30	218- 754	CAP - 3/8" tube	UAR
31	C 33577	BRACKET - oil filter	1
32	C 33446	HEAD - oil filter	1
33	121- 21	BOLT - 1/4" - 20 x 1/2"	4
34	217- 333	FITTING - 90° 3/8" NPTF x 3/4" barb stem	2
35	C 33445	FILTER - oil	1
36	C 33544	TUBE - filter to tank	1
37	C 33556	HOSE - formed 90°	1
38	NSS	HOSE - 3/4" x 4" (use C29697 cut to length)	2
39	217- 366	FITTING - 90° 1" hose x 1-1/16" - 20 UNF	1
40	C 33766	TUBE - hydraulic	1
41	C 25245	FITTING - hydraulic	1
42	C 33765	HOSE - regulator valve "by pass" to travel valve	1
43	C 33834	BRACKET - support	1
44	C 33218	CLAMP - tube	1
45	113- 102	BOLT - 5/16" - 18 x 3/4"	2
46	131- 911	NUT - 5/16" - 18 flange	2
47	195- 521	WASHER - 5/16"	1

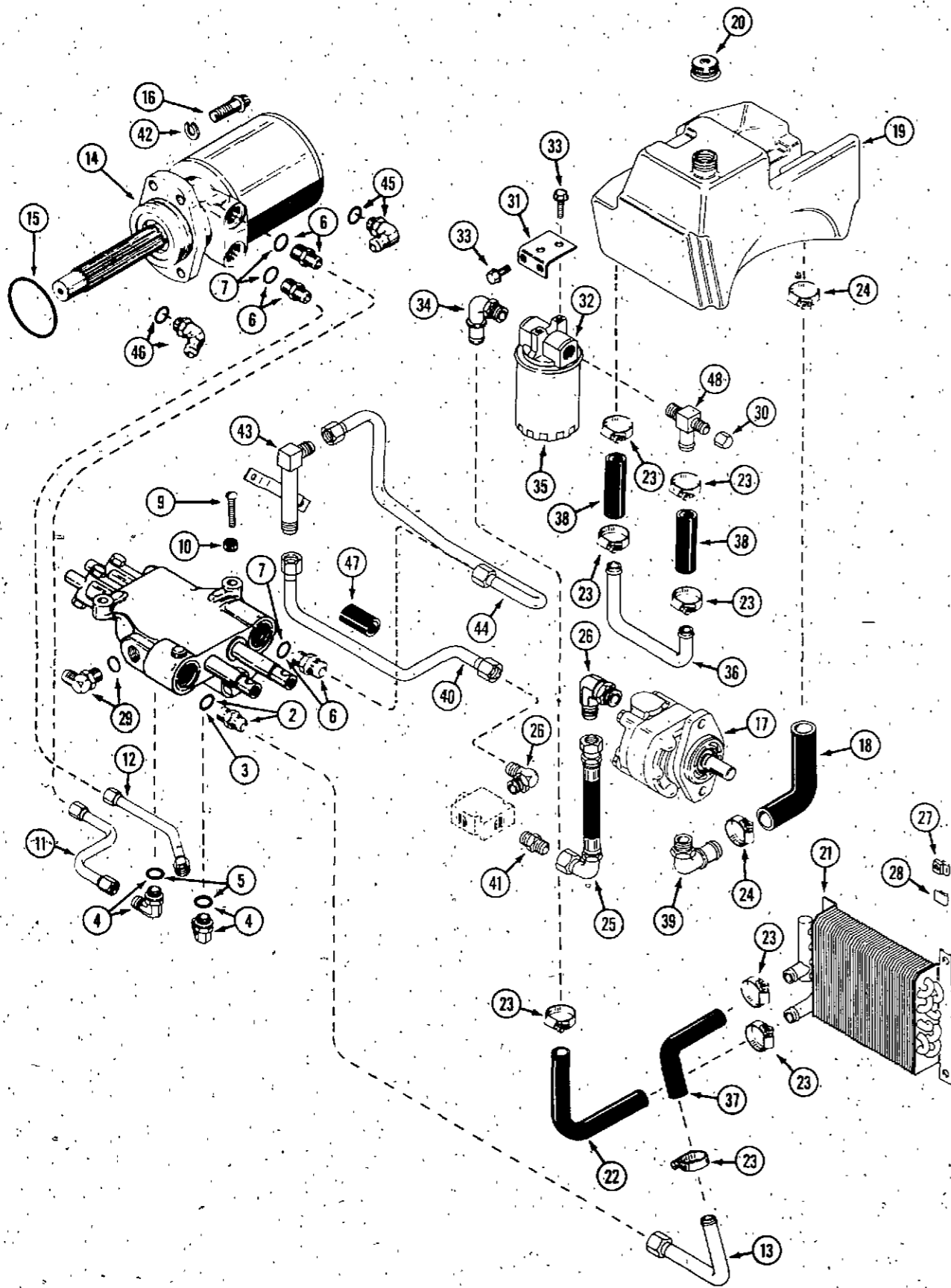

HYDRAULIC SYSTEM

(3018PS PIN 14181900 and after)
(4020PS PIN 14184000 and after)

REF.	PART NO.	DESCRIPTION	REQ'D
1	C 33473	VALVE - control (repairs page 57)	1
2	218- 5065	FITTING - 3/4" x 7/8"	1
3	218- 5007	"O" RING	1
4	218- 5107	FITTING - 90° elbow	2
5	218- 5007	"O" RING	1
6	218- 5062	FITTING - 5/8" x 7/8" "O" ring	UAR
7	218- 5007	"O" RING	1
9	C 27764	SCREW - 5/16" - 18 x 1-1/4" round head	2
10	131- 351	NUT - lock 5/16"	2
11	C 37220	TUBE - valve to upper motor port (3018PS)	1
11	C 29657	TUBE - valve to upper motor port (4020PS)	1
12	C 37221	TUBE - valve to lower motor port (3018PS)	1
12	C 29658	TUBE - valve to lower motor port (4020PS)	1
13	C 31435	TUBE - valve "out" to heat exchanger	1
14	C 30939	MOTOR - hydraulic (repairs page 55) (3018PS)	1
14	C 33234	MOTOR - hydraulic (4020PS) (repairs page 55)	1
15	C 28949	SEAL - motor to transmission	1
16	166- 86	SCREW - 1/2" - 13 x 1" 12 pt. flange	4
17	C 33579	PUMP - hydraulic 3/4" shaft (repairs page 53)	1
18	C 33551	HOSE - pump inlet	1
19	C 33180	RESERVOIR - oil	1
20	C 37093	CAP - reservoir	1
21	C 31295	EXCHANGER - heat	1
22	C 33555	HOSE - formed 90°	1
23	214- 254	CLAMP - hose 1-1/4"	8
24	214- 14	CLAMP - hose 1-3/8"	2
25	C 33557	HOSE - pump to regulator	1
26	218- 5117	FITTING - 90° elbow	2
27	C 31973	"J" NUT - 1/4" - 20	4
28	C 31974	"U" Clip - retainer	4
29	C 37425	FITTING 90°, 3/8" x 1/2" - 20	UAR
30	218- 753	CAP - 1/2" - 20	1
31	C 33577	BRACKET - oil filter	1
32	C 33446	HEAD - oil filter	1
33	121- 21	BOLT - 1/4" - 20 x 1/2"	4
34	217- 333	FITTING - 90° 3/8" NPTF x 3/4" barb stem	2
35	C 33445	FILTER - oil	1
36	C 33544	TUBE - filter to tank	1
37	C 33556	HOSE - formed 90°	1
38	NSS	HOSE - 3/4" x 4" (use C29697 cut to length)	2
39	217- 366	FITTING - 90° 1" hose x 1-1/16" - 20 UNF	1
40	C 44920	TUBE - regulator valve "by pass" to PTO valve "in" (3018PS)	1
40	C 44921	TUBE - regulator valve "by pass" to PTO "in" (4020PS)	1
41	C 25245	FITTING - hydraulic	1
42	192- 23	LOCK WASHER - 1/2"	4
43	C 44908	FITTING - elbow	1
44	C 44922	TUBE - PTO "out" to travel valve "in" (3018PS)	1
44	C 44923	TUBE - PTO "out" to travel valve "in" (4020PS)	1
45	218- 5107	FITTING - 90° 7/8" - 14 (3018PS) upper port	1
46	218- 5137	FITTING - 45° 7/8" - 14 x 5/8" (3018PS) lower port	1
47	C 45045	CUSHION - tube	1
48	C 44911	FITTING - "T" return	1

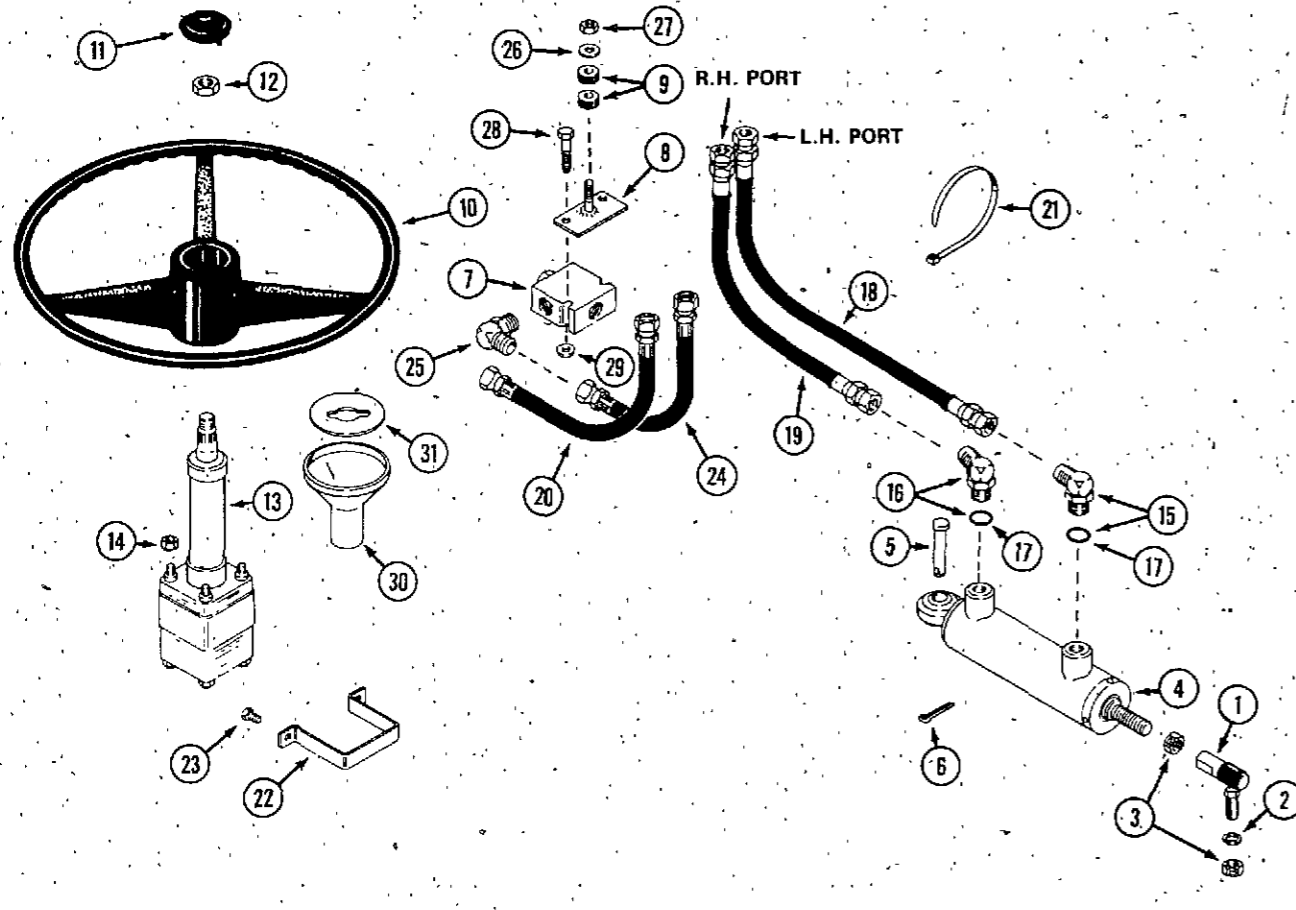

POWER STEERING

3016PS 3018PS, 3020PS
4016PS, 4018PS, 4020PS

REF.	PART NO.	DESCRIPTION	REQ'D
1	C 44640	BALLJOINT - 1/2" R.H. thread	1
2	192- 23	LOCKWASHER - 1/2"	1
3	129- 165	NUT - 1/2" N.F. lock	2
4	NSS*	CYLINDER - hydraulic (use C44628 to service all)	1
4	C 44628 **	CYLINDER - hydraulic	1
4	C 44852 **	KIT - seal, hydraulic cylinder	1
5	C 14717	PIN - clevis 5/8" dia.	1
6	132- 91	PIN - cotter 3/16" x 1"	1
7	C 33554	VALVE - regulator	1
8	C 33763	BRACKET - mounting	1
9	C 15410	WASHER - cushion	2
10	C 27990 *	WHEEL - steering (shown)	1
10	C 37302 **	WHEEL - steering	1
11	C 16945 *	CAP - steering wheel	1
11	C 42591 **	CAP - steering wheel	1
12	129- 127	NUT - 5/8" - 18	1
13	C 33743	PUMP - steering	1
14	129- 162	NUT - 5/16" - 24	3
15	218- 5105	FITTING - 90° adjustable elbow 3/8" x 9/16" - 18	1
16	218- 5135	FITTING - 45° adjustable elbow 3/8" x 9/16" - 18	1
17	218- 5005	"O" RING	1
18	C 33560	HOSE - hydraulic 23" (3016PS, 3018PS, 3020PS)	1
18	C 32399	HOSE - hydraulic 25" (4016PS, 4018PS, 4020PS)	1
19	C 33561	HOSE - hydraulic 19" (3016PS, 3018PS, 3020PS)	1
19	C 33750	HOSE - hydraulic 21" (4016PS, 4018PS, 4020PS)	1
20	C 28275	HOSE - hydraulic 16" handpump "out" to travel valve	1
21	C 22947	TIE - nylon	1
22	C 33545	STRAP - mounting	1
23	121- 21	BOLT - 1/4" - 20 x 1/2"	2
24	C 33762	HOSE - regulator valve (reg) to hand pump (in)	1
25	218- 5128	FITTING - hydraulic 90°, regulator valve (reg.)	1
26	195- 2175	WASHER - 5/16"	1
27	131- 69	NUT - lock 5/16" - 18	1
28	113- 132	BOLT - 1/4" - 20 x 1-3/4"	2
29	131- 934	NUT - flange lock 1/4" - 20	2
30	C 39504 **	BOOT - steering column	1
31	C 39507 **	INSERT - boot	1

*Use before PIN:
**Use PIN and after:
3018PS - 14181900
4020PS - 14184000
All others before PIN

MANUAL PUMP (POWER STEERING)

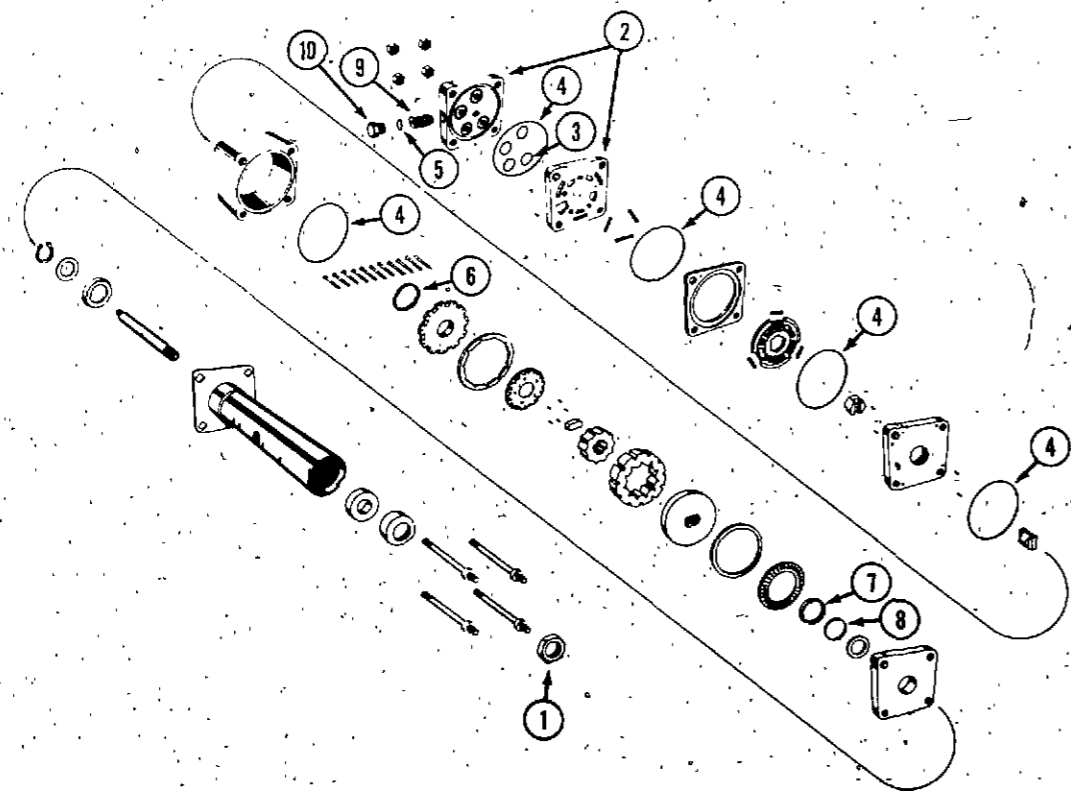

REF.	PART NO.	DESCRIPTION	REQ'D
1	C 33743	PUMP - steering, manual	1
1	129- 127	NUT - 5/8" - 18	1
2	C 34485	KIT - cover and manifold	1
2	C 30281	KIT - cover and manifold	1
3	NSS	"O" RING	4
4	NSS	RING - seal	5
5	NSS	"O" RING	1
6	NSS	SEAL - commutator	1
7	NSS	SEAL - face	1
8	NSS	RING - back-up	1
9	C 34484	VALVE - relief	1
10	C 34483	PLUG - relief valve	1

HYDRAULIC PUMP (PARKER-HANNIFIN)

Use on model 4016

REF.	PART NO.	DESCRIPTION	REQ'D
1	C 31958	PUMP - hydraulic 1/2" shaft	1
2	F 53109	PIN - dowel	2
3	C 31987	COVER - rear	1
4	C 15731	GEAR ASSEMBLY - driven	1
5	C 15732	"O" RING - cover	2
6	C 15733	BODY - pump	1
7	C 15734	COVER - front	1
8	C 15735	SEAL - shaft	1
9	NSS	GEAR ASSEMBLY - drive (1/2" shaft) (use C31958)	1
10	C 15737	PLATE - wear	1
11	C 15738	SHIELD - heat	1
12	C 15739	GASKET	1
13	C 15740	SEAL	1
14	113- 111	BOLT	4
15	C 31988	KEY - 1/8" square 3/4" long (1.587 mm x 19.05mm)	1
16	C 19115	WASHER	4

HYDRAULIC PUMP (PARKER-HANNIFIN)

(Use on power steering models)

	C 33579	PUMP - hydraulic 3/4" shaft	1
1	C 32955	KIT - seal	1
2	C 33110	SEAL - shaft	1
3	NSS	SEAL - "V" ("V" side towards cover)	1
4	NSS	GASKET	1
5	NSS	SHIELD - heat	1
6	NSS	PLATE - wear (bronze side towards gears)	1
7	NSS	PLATE - thrust (bronze side towards gears)	1
8	C 33111	"O" RING	2
9	126- 13	KEY - 3/16" x 5/16" woodruff (pump shaft)	1

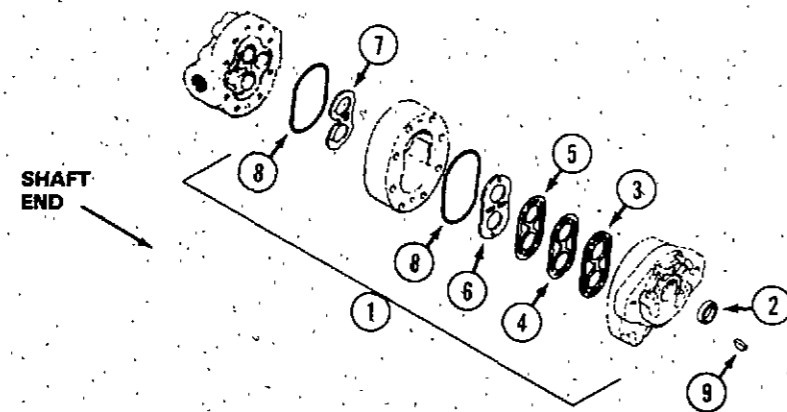
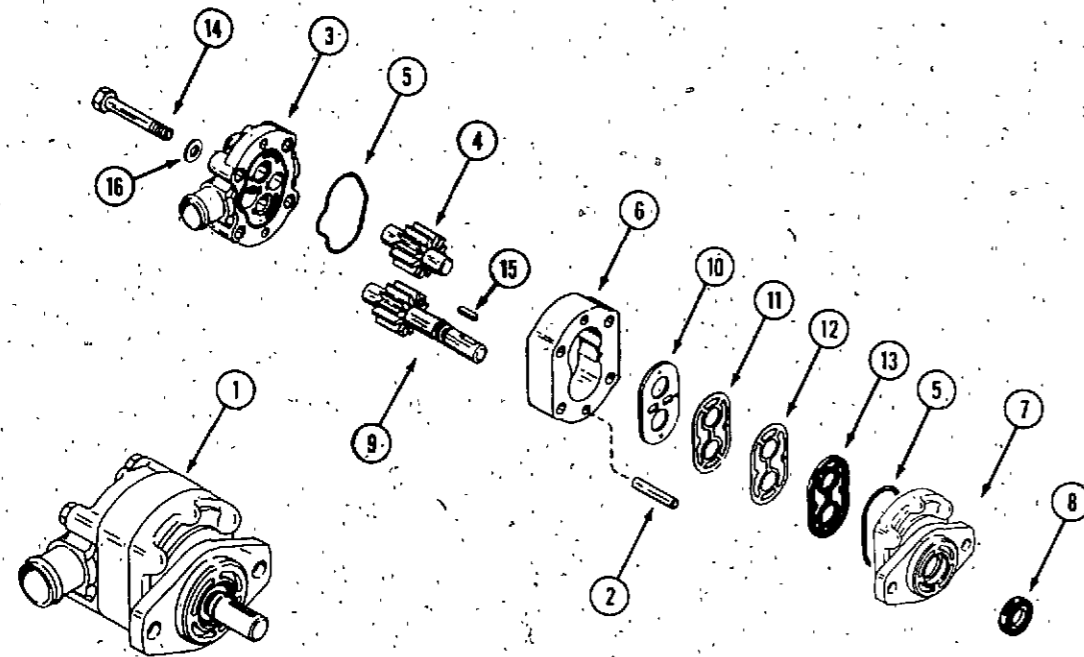

HYDRAULIC DRIVE MOTOR

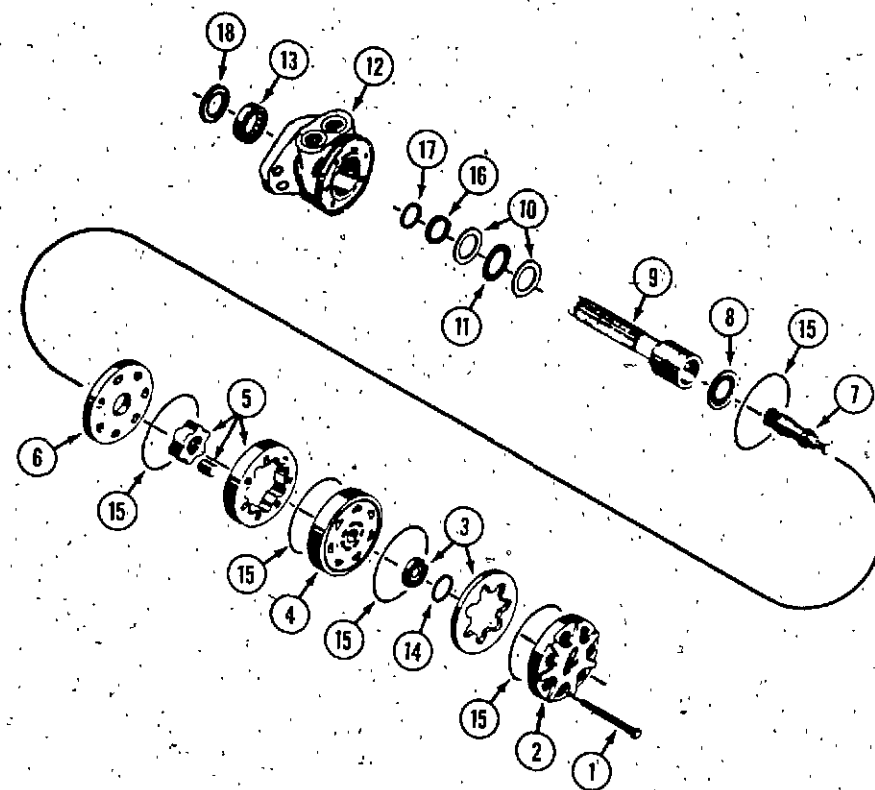

REF.	PART NO.	DESCRIPTION	REQ'D
	C 33234	MOTOR - hydraulic (4016, 4016PS, 4018PS, 4020PS)	1
	C 30939	MOTOR - hydraulic (3016PS, 3018PS, 3020PS)	1
1	28- 668	BOLT - 3/8" - 24 x 4-1/4" (3016PS, 3018PS, 3020PS)	7
1	C 31327	BOLT - 3/8" - 24 x 4-5/8" (4016, 4016PS, 4018PS, 4020PS)	7
2	C 31309	COVER - end	1
3	C 31310	COMMUTATOR AND RING SET	1
4	C 31311	MANIFOLD	1
5	C 31312	ROTOR ASSEMBLY (3016PS, 3018PS, 3020PS)	1
5	C 31313	ROTOR ASSEMBLY (4016, 4016PS, 4018PS, 4020PS)	1
6	C 31314	PLATE - wear	1
7	C 31315	LINK - drive (3016PS, 3018PS, 3020PS)	1
7	C 31316	LINK - drive (4016, 4016PS, 4018PS, 4020PS)	1
8	C 31317	BEARING - thrust	1
9	C 31318	SHAFT - coupling	7
10	C 31319	WASHER - trust	2
11	C 31320	BEARING - thrust	1
12	C 31321	HOUSING - drive end	1
13	C 31322	BEARING - outer	1
	C 31323	KIT - seal	1
14	NSS	SEAL - commutator ring	1
15	NSS	SEAL - ring	5
16	NSS	SEAL - ring	1
17	NSS	WASHER - backup	1
18	NSS	SEAL - dirt (not used)	1

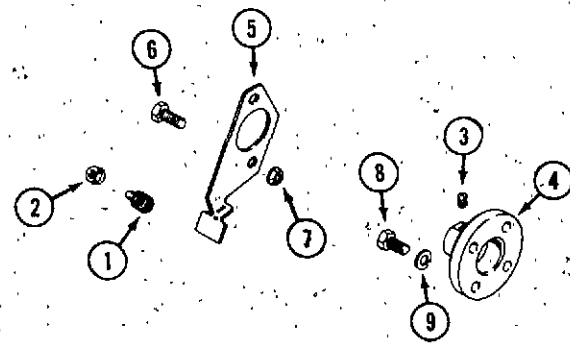

PUMP MOUNTING COMPONENTS			
REF.	PART NO.	DESCRIPTION	REQ'D
1	C 32437	MOUNT - rubber	1
2	131- 911	NUT - 5/16" - 18 flange lock	2
3	C 32199	SCREW - Set 5/16" - 18 x 5/16" socket (use loctite)	2
4	C 31964	ADAPTER - drive (4016)	1
4	C 33553	ADAPTER - drive (3016PS, 3018PS, 3020PS, 4016PS, 4018PS, 4020PS)	1
5	C 33506	PLATE - pump torque arm (4016)	1
5	C 33552	PLATE - pump torque arm (3016PS, 3018PS, 3020PS, 4016PS, 4018PS, 4020PS)	1
6	113- 208	BOLT - 3/8" - 16 x 1-1/4" hex	2
7	131- 1352	NUT - 3/8" - 16 flange lock	2
8	113- 103	BOLT - 5/16" - 18 x 1" hex	4
9	192- 20	LOCKWASHER - 5/16"	4

HYDRAULIC CONTROL VALVE

REF.	PART NO.	DESCRIPTION	REQ'D
1	C 33473	VALVE - control, two spool	1
2	C 29956	CAP - end	2
3	C 28217	"O" RING - end cap	1
4	C 28856	SEAL - spool	4
5	C 29951	SPRING - centering	2
6	211- 208	BALL - steel 5/16" (7.94 mm)	1
7	C 21507	SPRING - relief	2
8	C 17433	SCREW - relief adjust	1
9	C 17435	GASKET - relief adjust cap	1
10	129- 531	CAP - adjust screw	2
11	C 26668	DETENT - spool	1
12	C 28707	SPACER - detent	1
13	C 28706	SPRING - detent-return	1
14	C 28705	WASHER - return	2
15	NSS	SPRING - relief (use C21511 relief kit)	1
16	211- 5	BALL - steel 3/16" (4.76 mm)	2
17	C 17438	COVER - detent	1
18	C 28708	SCREW - detent	2
19	C 17444	SPRING - detent	4
20	169- 114	SCREW - cover	4
21	221- 841	PLUG - pipe	1
22	C 21506	RETAINER - ball seat	1
23	C 26665	SCREW - adjust, relief	1
24	C 26664	GASKET - adjust cap	1
25	C 26666	CAP - adjust screw	1
26	C 26663	SEAT - relief ball	1
27	C 34555	NUT - lock	1
28	C 29950	WASHER - spring retaining	2
29	C 29958	DETENT - spool	1
30	211- 7	BALL - steel 1/4" (6.35 mm)	2
31	C 17443	SCREW - detent	2
	C 30002	KIT - seal	1

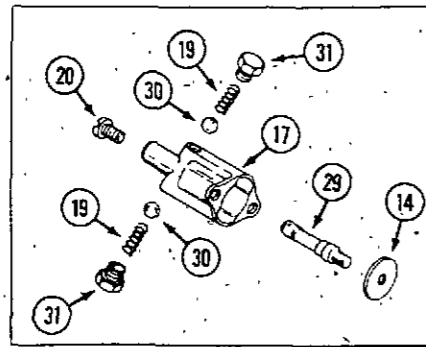

TRAVEL SECTION DETENT GROUP

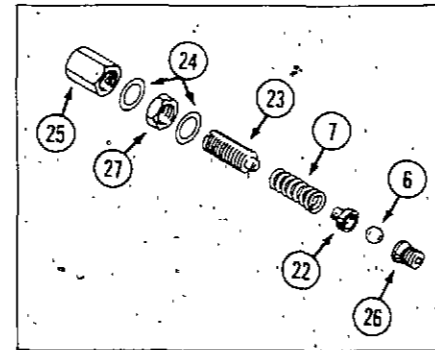

TRAVEL SECTION RELIEF GROUP

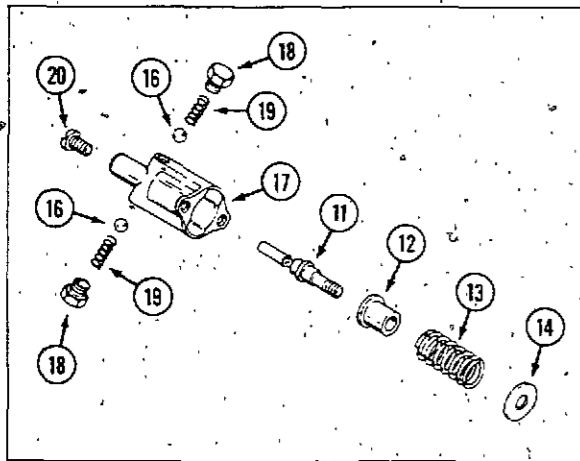

LIFT SECTION DETENT GROUP

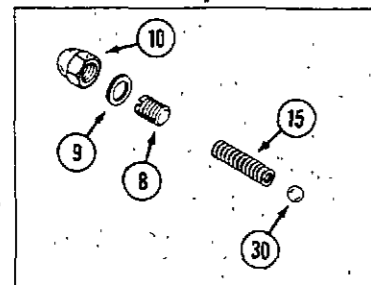

LIFT SECTION RELIEF GROUP

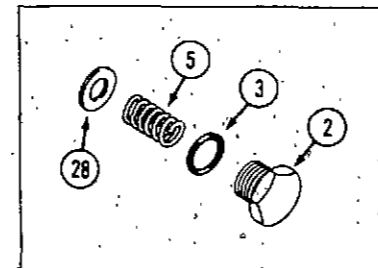
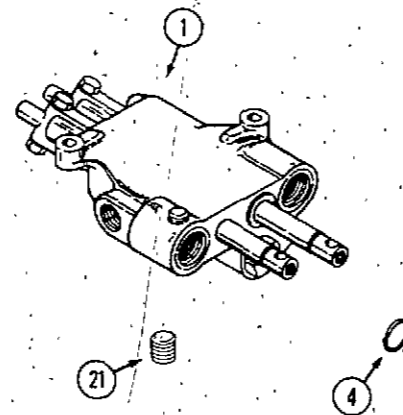

HOLDING SECTION GROUP

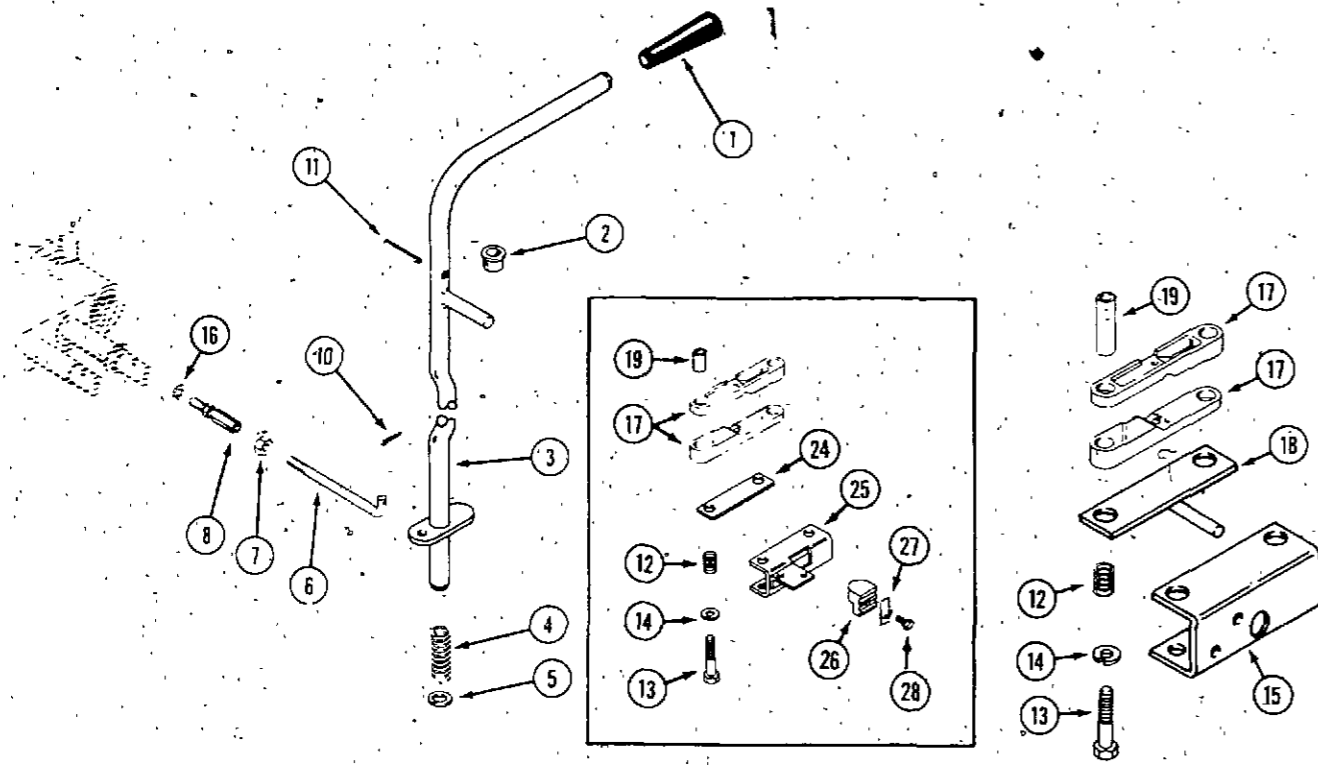

SPEED CONTROL

REF.	PART NO.	DESCRIPTION	REQ'D
1	C 28237	KNOB - speed control	1
2	C 29636	BUSHING - lever	1
3	C 37250	LEVER - speed control	1
4	C 10482	SPRING - compression	1
5	NSS	WASHER - nylon (use C44383)	1
6	C 31670	ROD - control	1
7	129- 122	NUT - 5/16" N.F. hex, zinc plated	1
8	C 19025	JOINT - ball	1
9	195- 521	WASHER - 5/16"	1
10	132- 320	PIN - cotter 3/32" x 3/4"	1
11	138- 2072	PIN - roll 1/8" x 1-3/4"	1
12	C 30827	SPRING - locator	2
13	113- 14	BOLT - 1/4" 20 x 2"	2
14	192- 19	LOCKWASHER - 1/4"	2
15	C 31678	CARRIER - locator	1
16	192- 20	LOCKWASHER - 5/16"	1
17	C 32362	LOCATOR - half	2
18	C 31674	ACCUATOR - switch	1
19	C 29653	SPACER - tube	2
20	C 44384 *	STRAP - retainer	1
21	113- 3 *	BOLT - 1/4" - 20 x 3/4"	2
22	192- 19 *	LOCKWASHER - 1/4"	2
23	129- 101 *	NUT - 1/4" - 20	2
24	C 37254 *	SUPPORT - locator	1
25	C 37255 *	CARRIER - locator	1
26	C 37198 *	CAM - switch	1
27	C 44029 *	RETAINER - switch	1
28	187- 1328 *	SCREW - #8 - 18 x 3/8"	1

Use PIN and after:
 3018PS - 14181900
 4020PS - 14184000

DRAWBAR AND TOW HITCH

1	C 13360	DRAWBAR	1
2	192- 23	LOCKWASHER - 1/2"	2
3	113- 424	BOLT - 1/2" x 1" N.C. hex	2

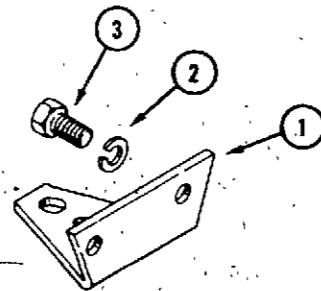

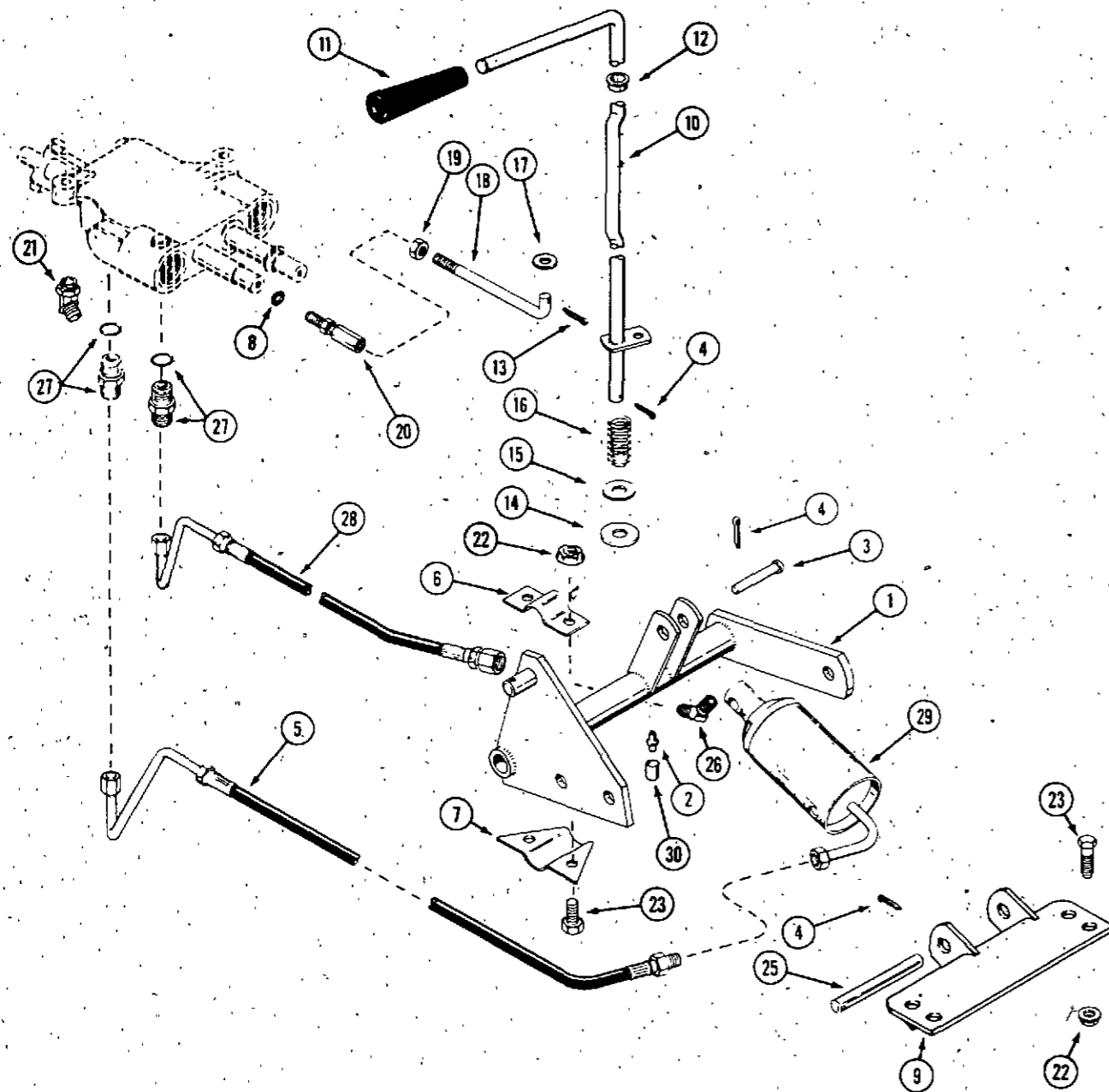

HYDRAULIC LIFT

REF.	PART NO.	DESCRIPTION	REQ'D
1	C 32259	SHAFT ASSEMBLY - lift	1
2	219- 17	FITTING - lubrication	1
3	C 29693	PIN - cylinder to lever, clevis	1
4	132- 310	PIN - cotter 1/8" x 1"	5
5	NSS*	HOSE - long (shown) (use C44743, 218-5134)	1
5	C 44743**	HOSE - long	1
6	C 17249	BRACKET - mounting, top	2
7	C 17250	BRACKET - mounting, bottom	2
8	192- 20	LOCKWASHER - 5/16"	1
9	C 33136	BRACKET - cylinder	1
10	C 33956	LEVER - lift control	1
11	C 29045	KNOB - control lever	1
12	C 29636	BUSHING - lift lever	1
13	132- 320	PIN - cotter 3/32" x 3/4"	1
14	195- 533	WASHER - 1/2"	1
15	NSS	WASHER - nylon (use C44383)	1
16	C 31681	SPRING - control lever	1
17	195- 521	WASHER - 5/16"	1
18	C 31670	ROD - control	1
19	129- 122	NUT - 5/16" N.F. hex	1
20	C 19025	BALLJOINT	1
21	218- 5134**	FITTING - 1/2" - 20 x 45°	2
22	131- 938	NUT - lock 3/8" N.C. hex	8
23	113- 208	BOLT - 3/8" - 16 x 1-1/4"	4
25	C 26188	PIN - cylinder base	1
26	218- 1093	FITTING - hydraulic 45° elbow	1
27	218- 5056*	FITTING - valve (includes 218-5004 "O" ring)	2
28	NSS*	HOSE - short (shown) (use C44742, 218-5134)	1
28	C 44742**	HOSE - short	1
29	C 26493	CYLINDER - lift	1
	C 30054	KIT - seal	1
30	C 13106	COVER - lubrication fitting	1

*Use before PIN:

**Use PIN and after:

3018PS - 14181900

4020PS - 14184000

All others before PIN

STARTER

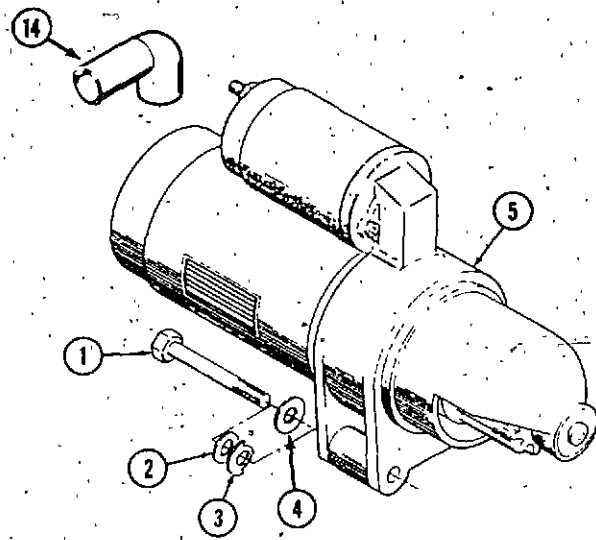

REF.	PART NO.	DESCRIPTION	REQ'D
1	C 32448	BOLT - thru 5/16" - 18 x 3-1/2"	2
2	192- 20	LOCKWASHER - 5/16"	2
3	C 32449	WASHER - special (outside mounting bolt)	1
4	C 20248	WASHER - 5/16" (inside mounting bolt)	1
5	C 32312	STARTER ASSEMBLY	1
6	C 32313	KIT - hardware	1
7	C 32314	KIT - solenoid (includes plunger)	1
8	C 32315	KIT - bushing (includes rear cap)	1
9	C 32316	HOLDER - brush (includes negative brush)	1
10	C 32317	KIT - brush	1
11	C 32318	KIT - shift lever	1
12	C 32319	CLUTCH - starter (includes gear)	1
13	C 32320	SEAL - dust	1
14	C 31618	COVER - terminal	1

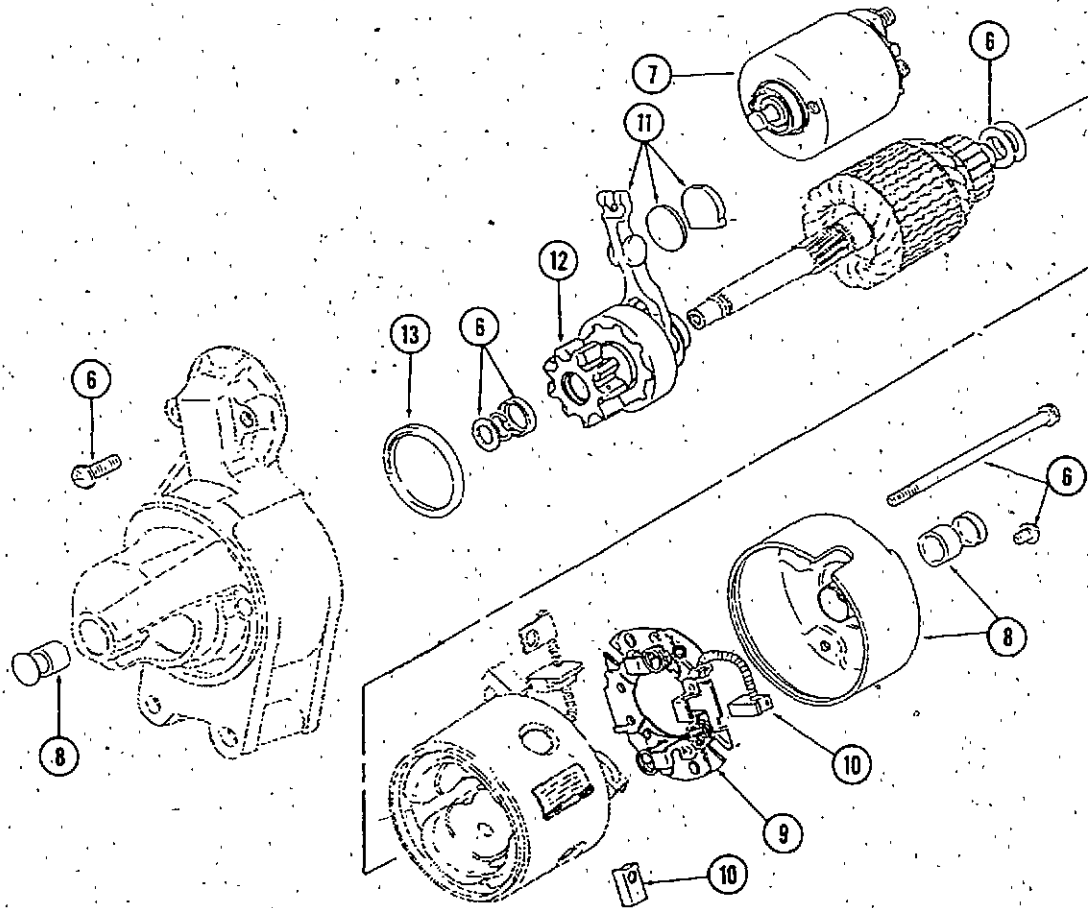

ELECTRICAL SYSTEM

(3018PS - use before PIN 14181900)
 (4020PS - use before PIN 14184000)
 (3016PS, 3020PS, 4016, 4016PS, 4018PS - All)

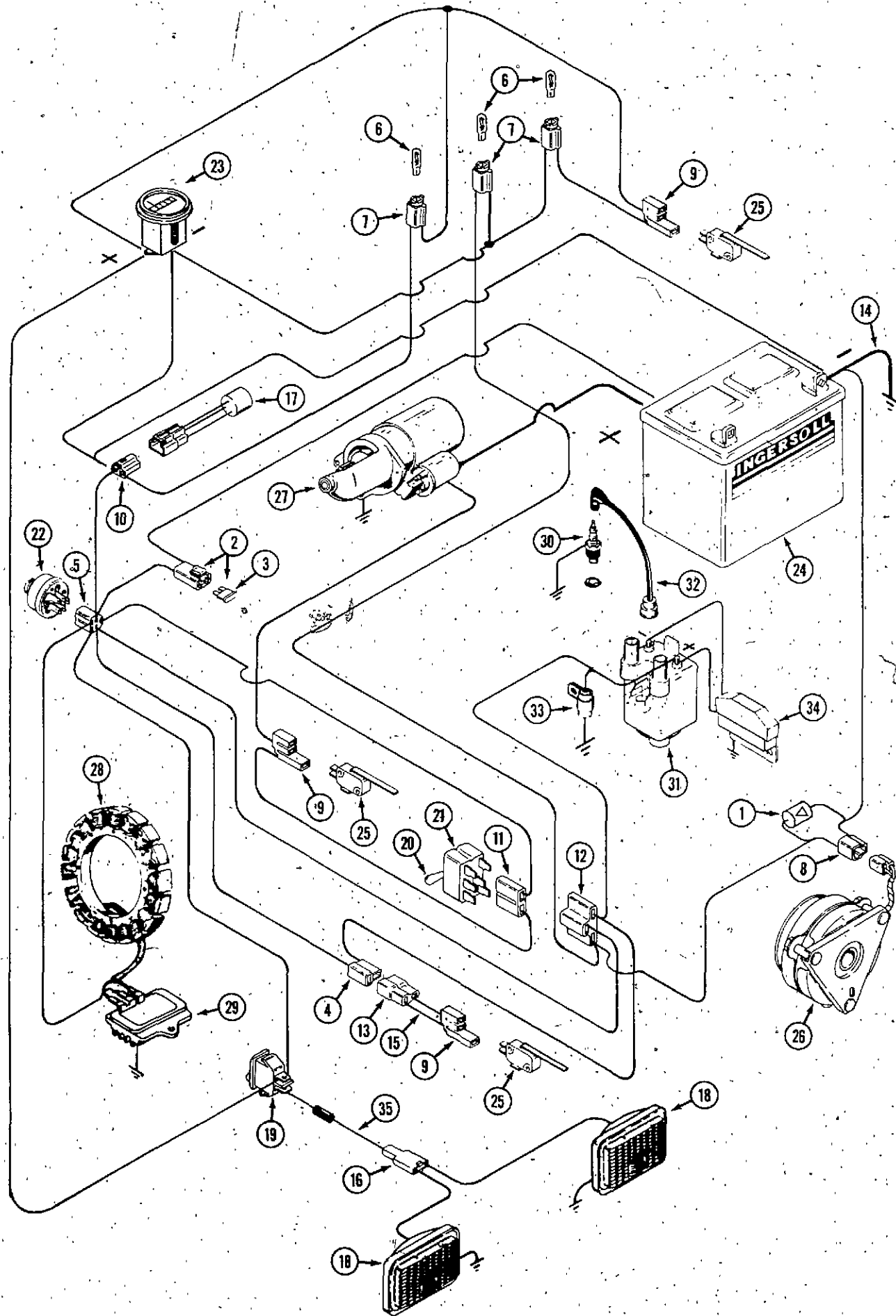

REF.	PART NO.	DESCRIPTION	REQ'D
	C 31941	HARNESS - wire	1
1	C 31986	KIT - diode, 6 amps, 15 volt	1
2	C 31947	KIT - fuse holder	1
3	C 30260	FUSE - 30 amp	1
4	C 25338	CONNECTOR - seat harness, male	1
5	C 24460	CONNECTOR - ignition switch	1
6	C 30262	BULB - indicator lights (not included with harness)	3
7	C 30263	SOCKET - bulb	3
8	C 31948	CONNECTOR - PTO	1
9	C 30279	CONNECTOR - switch	3
10	C 25486	CONNECTOR - sensor	1
11	C 31952	CONNECTOR - PTO switch, 2 terminal	1
12	C 31950	CONNECTOR - PTO switch, 3 terminal	1
13	C 24813	CONNECTOR - seat harness, female	1
14	C 24809	CABLE - battery negative to ground	1
15	C 31044	HARNESS - wire, seat switch (includes Ref. 9 and 13)	1
16	C 14537	CONNECTOR - headlights	1
17	C 31617	SENSOR - voltage (includes connector)	1
18	C 32178	HEADLIGHT - 12 volt (repairs page 69)	2
19	C 43044	SWITCH - headlight	1
20	C 31619	CAP - PTO switch	1
21	C 31937	SWITCH - PTO	1
22	C 30530	SWITCH - ignition (includes key and mounting hardware)	1
	C 32407	KEY - ignition	2
23	C 42929	HOURMETER	1
24	C 41010	BATTERY - 12 volt, 300 CCA	1
25	C 30275	SWITCH - inter-lock	3
26	C 33198	CLUTCH - PTO (see page 25 for repairs)	1
27	C 32312	STARTER AND SOLENOID - (see page 63 for repairs)	1
28	C 24956	STATOR - charging	1
29	C 32461	RECTIFIER - voltage, 12 volt	1
	C 32458	KIT - terminal connector	2
30	C 32454	SPARK PLUG - includes gasket	2
31	C 32296	COIL - ignition 12 volt	1
32	C 32299	CABLE KIT - spark plug 18-1/2"	2
33	C 32307	CONDENSER	1
34	C 32294	CONTROL - ignition	1
35	C 34181	WIRE - lights	1

ELECTRICAL SYSTEM

(3018PS PIN 14181900 and after)
(4020PS PIN 14184000 and after)

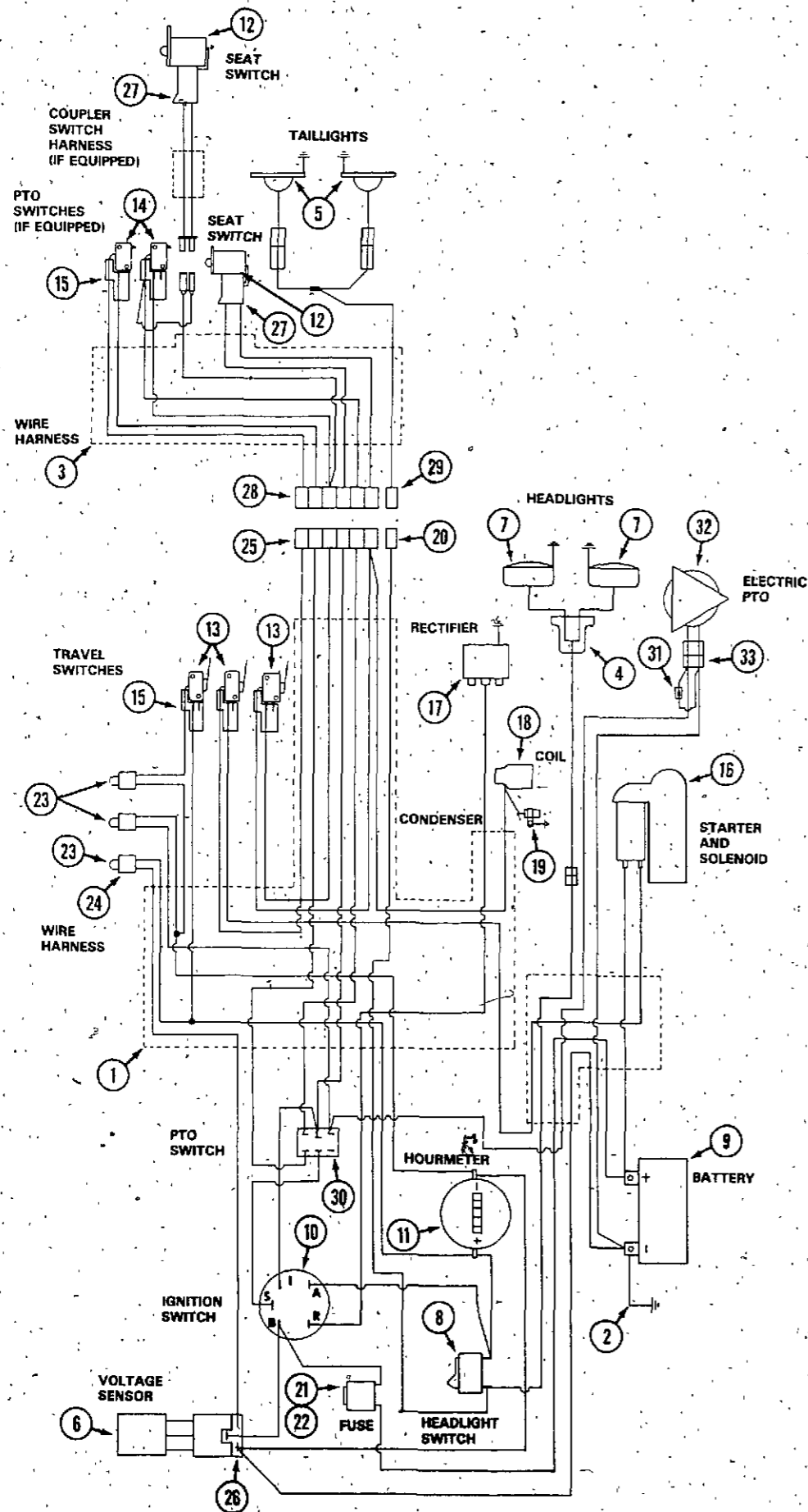

REF.	PART NO.	DESCRIPTION	REQ'D
1	C 43227	HARNES - wire, main	1
2	C 24809	CABLE - battery negative to ground	1
3	C 43228	HARNES - wire, seat switch, PTO and taillights	1
4	C 14537	CONNECTOR - headlights	1
5	C 37165	TAILLIGHT - rear (use 193-1000 nut for mounting)	2
6	C 31617	SENSOR - voltage	1
7	C 32178	HEADLIGHT - 12 volt (page 69 for service)	2
8	C 43044	SWITCH - headlights	1
9	C 41010	BATTERY - 12 volt 300 CCA	1
10	C 30530	SWITCH - ignition	1
	C 24460	CONNECTOR - ignition switch	1
11	C 42929	HOURLMETER	1
12	C 37298	SWITCH - seat (black)	2
13	C 30275	SWITCH - micro (at travel lever)	3
14	C 37399	SWITCH - micro (at PTO)	2
15	C 30279	CONNECTOR - micro switch	5
16	C 32312	STARTER AND SOLENOID - 12 volt (see page 63 for service)	1
17	C 32461	RECTIFIER - voltage, 12 volts	1
18	C 32296	COIL - ignition, 12 volt	1
19	C 32307	CONDENSER - 12 volt	1
20	C 42118	CONNECTOR - single female, taillight	1
21	C 31947	KIT - fuse holder	1
22	C 30260	FUSE - 30 amp	1
23	C 30262	BULB - indicator	3
24	C 30263	SOCKET - bulb	3
25	C 42117	CONNECTOR - six wire, harness, female	1
26	C 25486	CONNECTOR - three wire, sensor	1
27	C 37398	CONNECTOR - seat switch	2
28	C 42115	CONNECTOR - six wire, seat harness, male	1
29	C 42116	CONNECTOR - harness, taillight, male	1
30	C 31937	SWITCH - PTO	1
31	C 31986	KIT - diode	1
32	C 33198	CLUTCH - PTO, electric (see page 25 for repairs)	1
33	C 31948	CONNECTOR - PTO	1

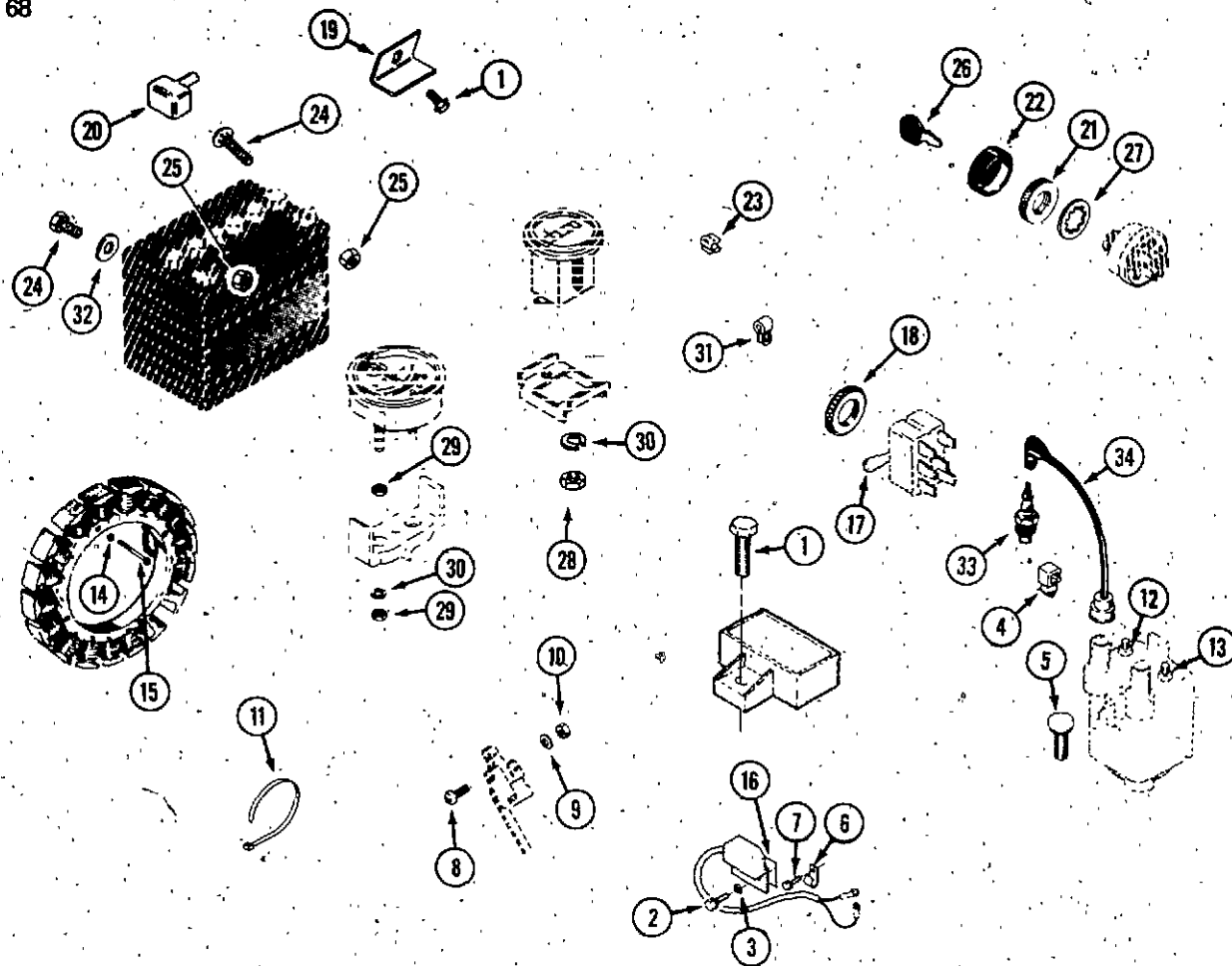

ELECTRICAL SYSTEM HARDWARE

REF.	PART NO.	DESCRIPTION	REQ'D
1	121- 21	BOLT - 1/4" - 20 x 1/2" flange lock	1
2	182- 525	BOLT - #10 - 32 x 3/8"	2
3	C 32460	LOCKWASHER - #10 internal tooth	12
4	C 32453	CLIP - wire	1
5	C 32456	BOLT - 1/4" - 20 x 1"	2
6	C 32455	CLIP - wire	2
7	187- 1036	SCREW - 1/4" - 20 x 1"	1
8	182- 12	SCREW - #4 - 40 x 1-1/8"	2
9	192- 13	LOCKWASHER - #4	2
10	129- 13	NUT - #4 - 40	2
11	C 22947	TIE - wire	UAR
12	C 32301	NUT - M5 metric (negative terminal)	1
13	C 32300	NUT - M4 metric (positive terminal)	1
14	193- 6	LOCKWASHER - #10	3
15	C 32459	SCREW - #10 - 32 x 1" self lock	3
16	C 32295	INSULATOR - ignition module	1
17	C 31619	CAP - PTO switch	1
18	C 33475	RETAINER - battery	1
19	C 33475	RETAINER - battery	1
20	C 24069	COVER - battery positive terminal	1
21	C 32396	NUT - switch	1
22	C 32397	CAP - nut	1
23	C 19521	CLIP - wire	3
24	111- 132	BOLT - 5/16" - 18 x 3/4" carriage	2
24	113- 3*	BOLT - 1/4" - 20 x 3/4" (shown)	2
25	129- 102	NUT - 5/16" - 18	UAR
25	129- 101*	NUT - 1/4" - 20	2
26	C 32407	KEY - ignition	1
27	C 23012	LOCKWASHER (early production)	1
28	129- 36	NUT - #8 - 36	2
29	129- 27	NUT - #10 NF	4
30	193- 6	LOCKWASHER - #10	2
31	C 42358	CLIP - wire (at tail light)	2
31	C 31977	CLIP - wire (at hydraulic PTO)	1
32	195- 518*	WASHER - 1/4"	2
33	C 32454	SPARK PLUG	2
34	C 32299	CABLE KIT - spark plug	2

*Use PIN and after:
3018PS - 14181900
4020PS - 14184000

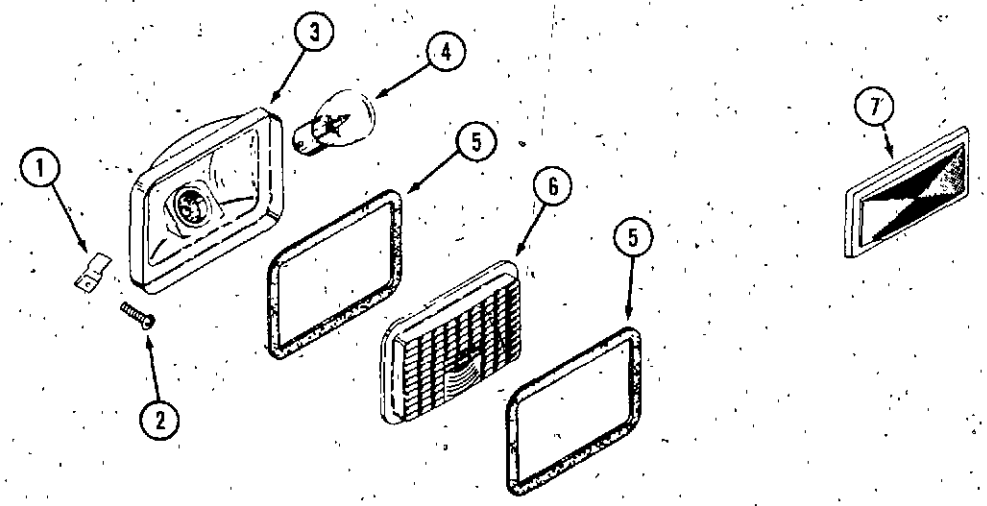

HEADLIGHT ASSEMBLY AND REAR REFLECTOR

1	C 29637	RETAINER - headlight	4
2	187- 1328	SCREW - No. 8 x 3/8"	4
	C 32178	HEADLIGHT ASSEMBLY	2
3	NSS	RECEPTACLE - headlight (order C32178)	1
4	C 28932	BULB - headlight	1
5	C 14304	GASKET - headlight	2
6	C 22573	LENS - headlight	1
7	C 30942	REFLECTOR - red, rear fender	2



DECALS

REF.	PART NO.	DESCRIPTION	REQ'D
1	C 33478	DECAL - "3018" Power Steering" hood L.H. (shown)	1
1	C 33479	DECAL - "3018 Power Steering" hood R.H.	1
2	C 33588	DECAL - fuel gauge	1
3	321- 4767	DECAL - hydraulic reservoir	1
4	C 33589	DECAL - shift range	1
5	C 33590	DECAL - brake	1
6	C 33476	DECAL - "3016 Power Steering" hood L.H. (shown)	1
6	C 33477	DECAL - "3016 Power Steering" hood R.H.	1
7	C 32007	DECAL - "4016" hood L.H. (shown)	1
7	C 32008	DECAL - "4016" hood R.H.	1
8	C 33484	DECAL - "4018" Power Steering" hood L.H. (shown)	1
8	C 33485	DECAL - "4018 Power Steering" hood R.H.	1
9	NSS	DECAL - Caution (use C44340)	1
10	C 30539	MEDALLION	1
11	C 30274	LENS - display	1
12	C 32093	DECAL - seat back "Ingersoll"	1
13	C 33486	DECAL - "4020 Power Steering" hood L.H. (shown)	1
13	C 33487	DECAL - "4020 Power Steering" hood R.H.	1
14	C 33480	DECAL - "3020 Power Steering" hood L.H. (shown)	1
14	C 33481	DECAL - "3020 Power Steering" hood R.H.	1
15	C 33482	DECAL - "4016 Power Steering" hood L.H. (shown)	1
15	C 33483	DECAL - "4016 Power Steering" hood R.H.	1
16	C 34184*	DECAL - flag	1
17	C 44340*	DECAL - "WARNING"	1
18	C 44341*	DECAL - "ATTENTION"	1
19	C 37197*	DECAL - steering wheel	1
20	C 37274*	DECAL - shift range	1
21	C 37275*	DECAL - PTO (if equipped)	1

*Use PIN and after:
 3018PS - 14181900
 4020PS - 14184000

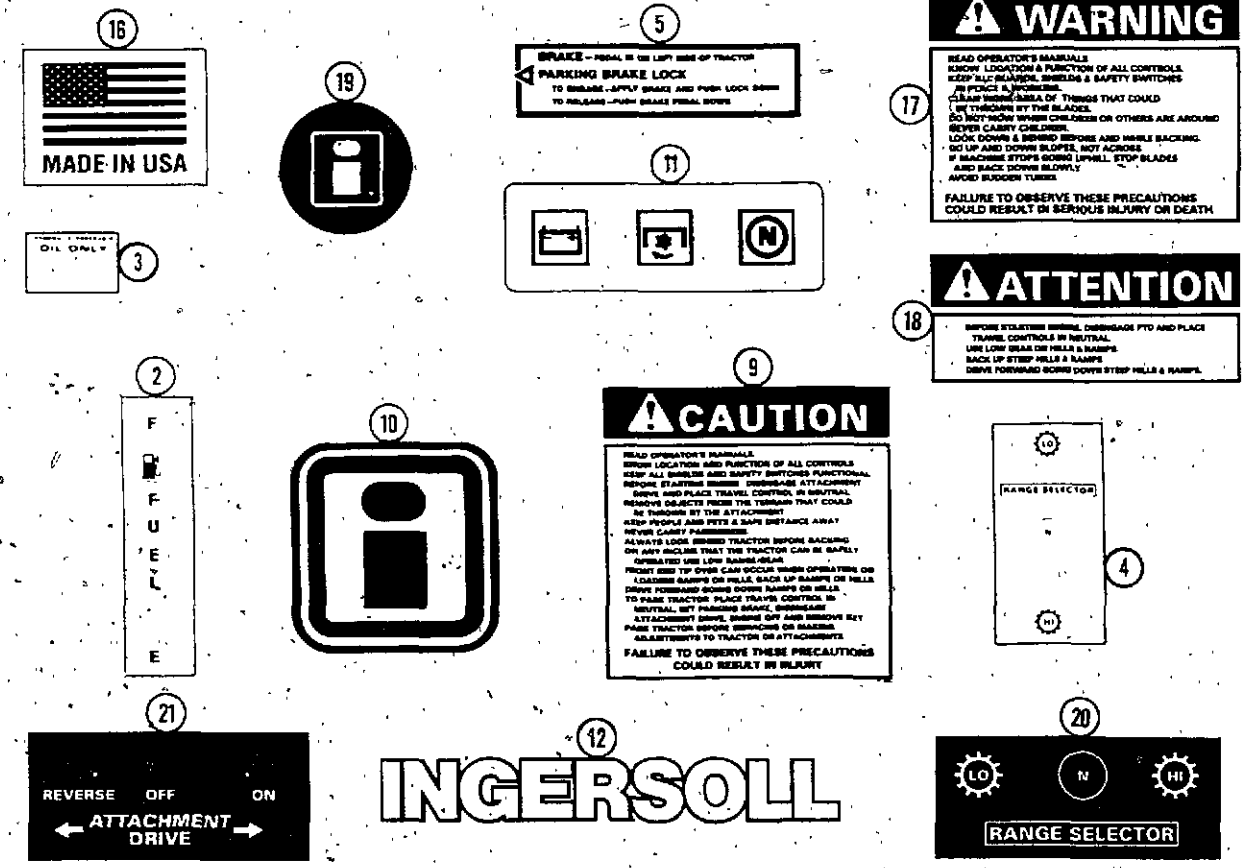

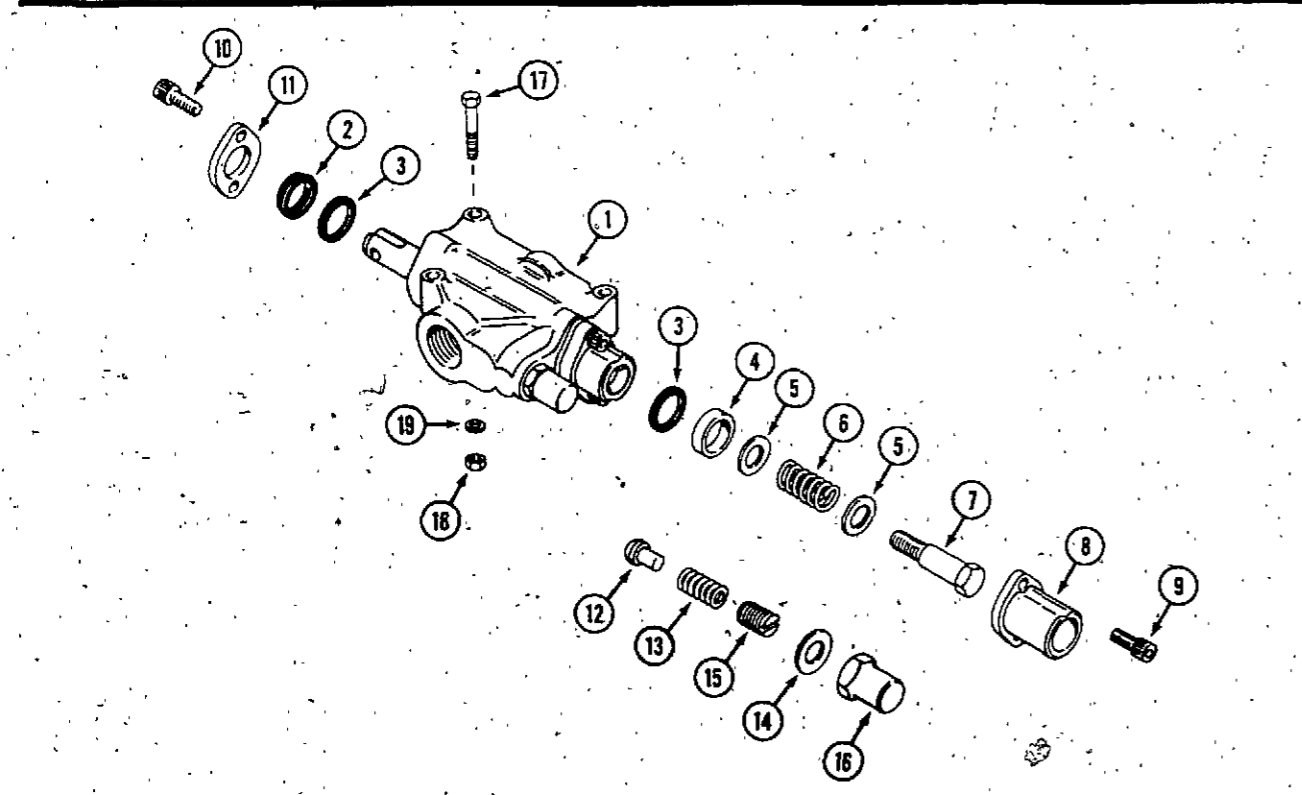
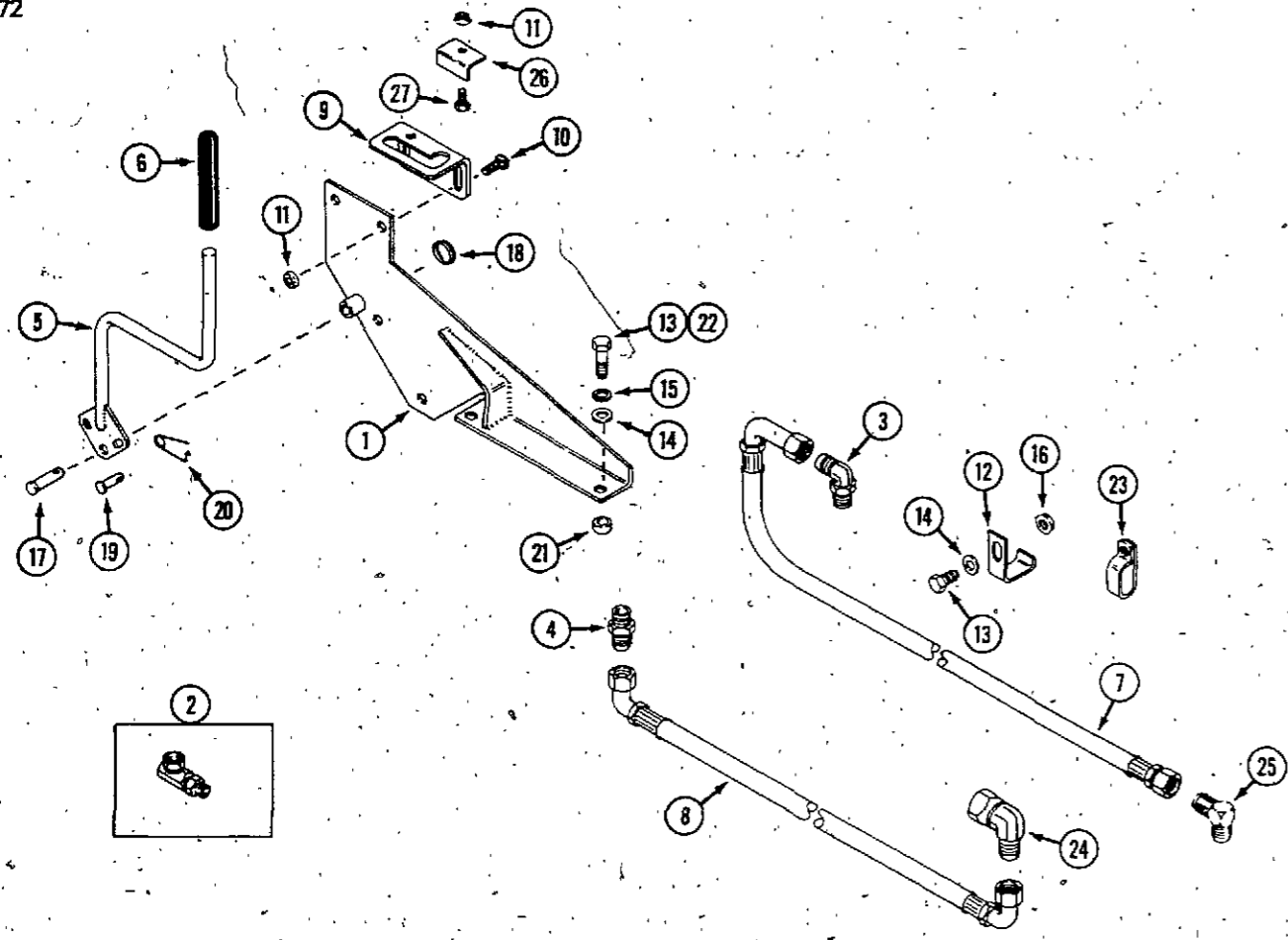

**HP31 HYDRAULIC PTO (3016PS, 3020PS) (3018PS before PIN 14181900)
HP41 HYDRAULIC PTO (4016, 4016PS) (4020PS before PIN 14184000)**

PTO HOSES AND MOUNTING BRACKET

REF.	PART NO.	DESCRIPTION	REQ'D
1	C 32200	BRACKET - valve mounting	1
2	218- 5201	FITTING - workport, 90° elbow 7/8" - 14 x 1/2" NPSM swivel	2
3	218- 5107	FITTING - inlet port, 7/8" - 14 x 7/8" - 14 flare, 90° adjustable elbow	1
4	218- 5062	FITTING - outlet port, 7/8" - 14 x 7/8" - 14 flare, straight	1
5	C 32403	HANDLE - valve	1
6	C 26020	GRIP - handle	1
7	C 34179	HOSE - pump to PTO 46-1/4" (HP31)	1
7	C 34180	HOSE - pump to PTO 39" (HP41)	1
8	C 32209	HOSE - PTO to travel valve 32" (HP31)	1
8	C 32210	HOSE - PTO to travel valve 34" (HP41)	1
9	C 32211	BRACKET - handle guide	1
10	111- 101	BOLT - 1/4" - 20 x 5/8" carriage	2
11	131- 934	NUT - 1/4" - 20 flange lock	2
12	C 32332	CLAMP - tube (HP31)	1
13	113- 103	BOLT - 5/16" - 18 x 1"	3
14	195- 521	WASHER - 5/16"	3
15	192- 20	LOCKWASHER - 5/16"	2
16	131- 911	NUT - 5/16" - 18 flange lock	1
17	C 32214	PIN - clevis 3/8" x 1-1/2"	1
18	C 28105	RING - retaining	1
19	C 28964	PIN - clevis 3/16" x 1"	1
20	C 10883	PIN - safety	1
21	C 29106	SPACER - 3/8" I.D. x 5/8" O.D. x 5/8" long (HP31)	2
22	113- 122	BOLT - 5/16" - 18 x 1-1/2" (HP31)	2
23	C 32213	CLAMP - tube (HP41)	1
24	218- 5232	FITTING - 90° swivel elbow 7/8" - 14	1
25	218- 475	FITTING - 90° elbow 7/8" - 14	1
26	C 32327	BRACKET - handle stop	1
27	113- 3	BOLT - 1/4" - 20 x 3/4"	1
	C 22947	TIE - nylon	1

PTO VALVE

1	C 30046	VALVE - hydraulic	1
2	C 26706	WIPER - spool	1
3	C 26707	RING - quad	2
4	C 26722	SPACER - end cap	1
5	195- 526	WASHER	2
6	C 26724	SPRING - centering	1
7	C 26725	BOLT - shoulder	1
8	C 26726	BONNET - end cap	1
9	165- 143	SCREW - 1/4" - 20 x 3/4" socket head	2
10	165- 142	SCREW - 1/4" - 20 x 5/8" socket head	2
11	C 26727	RETAINER - seal	1
12	C 26708	POPPET - relief	1
13	C 26709	SPRING - relief	1
14	C 26710	WASHER - aluminum, seal	1
15	C 26711	SCREW - adjustment, relief	1
16	C 26712	NUT - cap, relief	1
17	113- 5	BOLT - 1/4" x 1-1/2"	3
18	129- 101	NUT - 1/4"	3
19	192- 19	LOCKWASHER - 1/4"	3

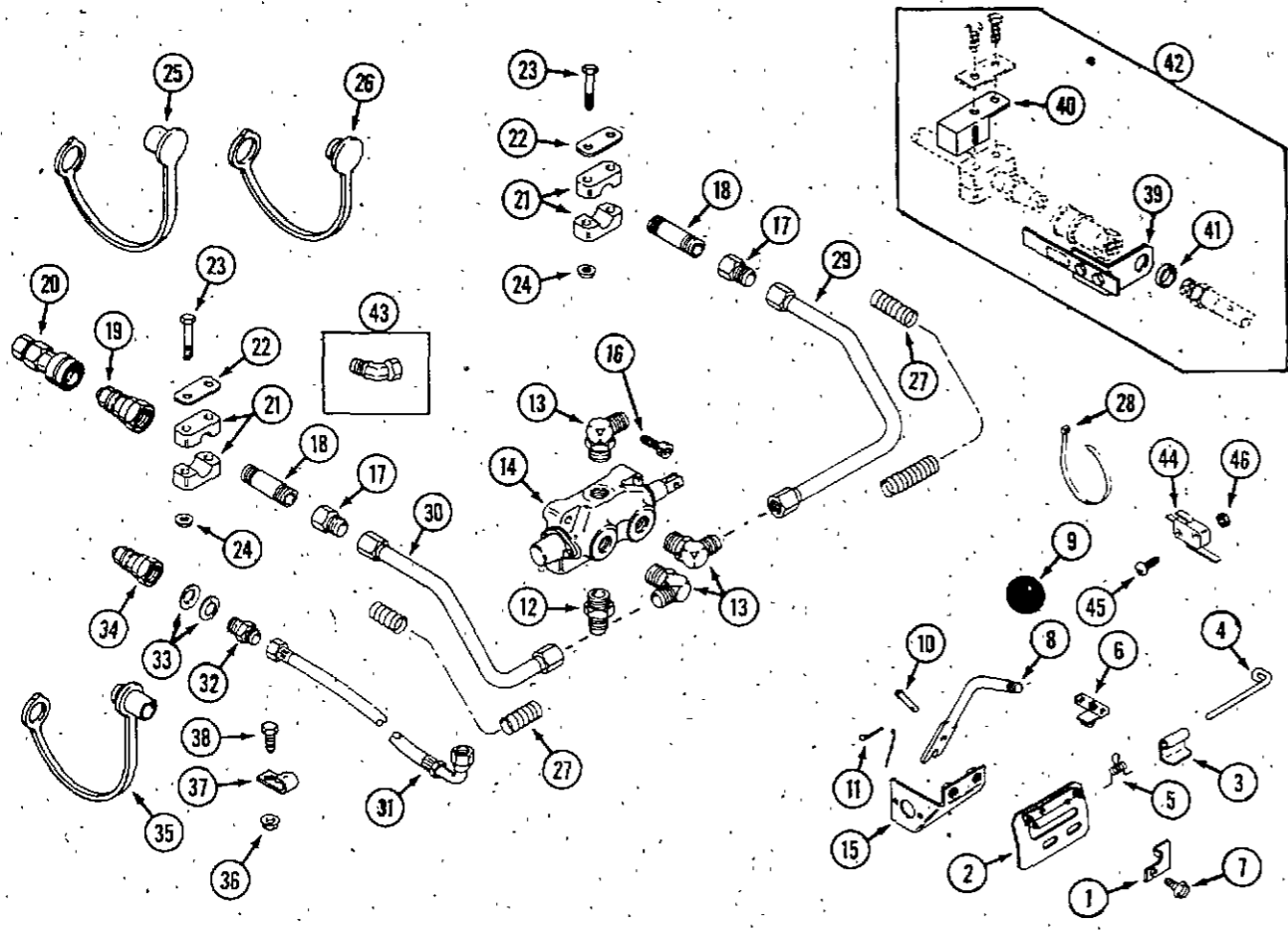

HP34 HYDRAULIC PTO

(for 3018PS PIN 14181900 and after)
 (for 4020PS PIN 14184000 and after)

REF.	PART NO.	DESCRIPTION	REQ'D
1	C 42198	LATCH - reverse lockout	1
2	C 42078	GATE - shift	1
3	C 42081	STOP - lever	2
4	C 42082	PIN - hinge	1
5	C 42083	SPRING - torsion	1
6	C 37400	ACTUATOR - switch	1
7	C 29691	SCREW - 5/16" - 18 x 1"	2
8	C 44936	LEVER - PTO	1
9	C 10487	KNOB	1
10	C 28964	PIN - clevis 3/16" x 1"	2
11	132- 329	PIN - cotter 1/16" x 3/4"	2
12	218- 5062	FITTING - 7/8"	1
13	218- 5107	FITTING - 90° 7/8"	3
14	C 30046	VALVE - PTO (repairs page 73)	1
15	C 37401	BRACKET - actuating	1
16	61 420	SCREW - 1/4" - 20 x 1-1/4" socket head	2
17	218- 465	FITTING - 1/2" x 7/8" - 14	2
18	C 37142	NIPPLE - pipe	2
19	C 37187	COUPLING - quick, male 7/8"	2
20	C 37188	COUPLING - quick, female 7/8"	1
21	C 37144	CLAMP	4
22	C 37145	COVER - clamp	6
23	113- 15	BOLT - 1/4" - 20 x 2-1/4"	4
24	131- 934	NUT - 1/4" - 20 flange lock	4
25	C 40641	CAP - dust	1
26	C 40642	PLUG - dust	1
27	C 37454	CONDUIT - corrugated (cut to length)	2
28	C 22947	TIE - nylon	4
29	C 37233	TUBE - L.H.	1
30	C 37234	TUBE - R.H.	1
31	C 44939	HOSE - hydraulic 44"	1
32	218- 443	FITTING - 3/8" x 1/4"	1
33	C 37249	WASHER - spring	2
34	C 41043	COUPLING - quick, male 9/16"	1
35	C 33404	CAP - dust	1
36	131- 934	NUT - 1/4" - 20 flange lock	1
37	C 32455	CLIP - "J"	1
38	187- 1036	SCREW - 1/4" - 20 x 1/2" self-tap	1
39	C 37439	KEY - coupling switch	1
	C 37440	DECAL	1
	113- 1	BOLT - 1/4" - 20	2
	195- 518	WASHER - 1/4"	2
40	C 37437	BRACKET - switch mounting	1
41	C 37459	CUSHION - key	1
42	C 42048	KIT - coupler switch (optional)	1
43	217- 1086	FITTING - 45° (3018PS)	2
44	C 37399	SWITCH - interlock	2
45	C 33696	SCREW - #4 - 40 x 1-1/8"	2
46	C 33697	NUT - #4 - 40	2
	C 37435	HARNES - wire, PTO switches	1
	C 37275	DECAL - "ON-OFF"	1

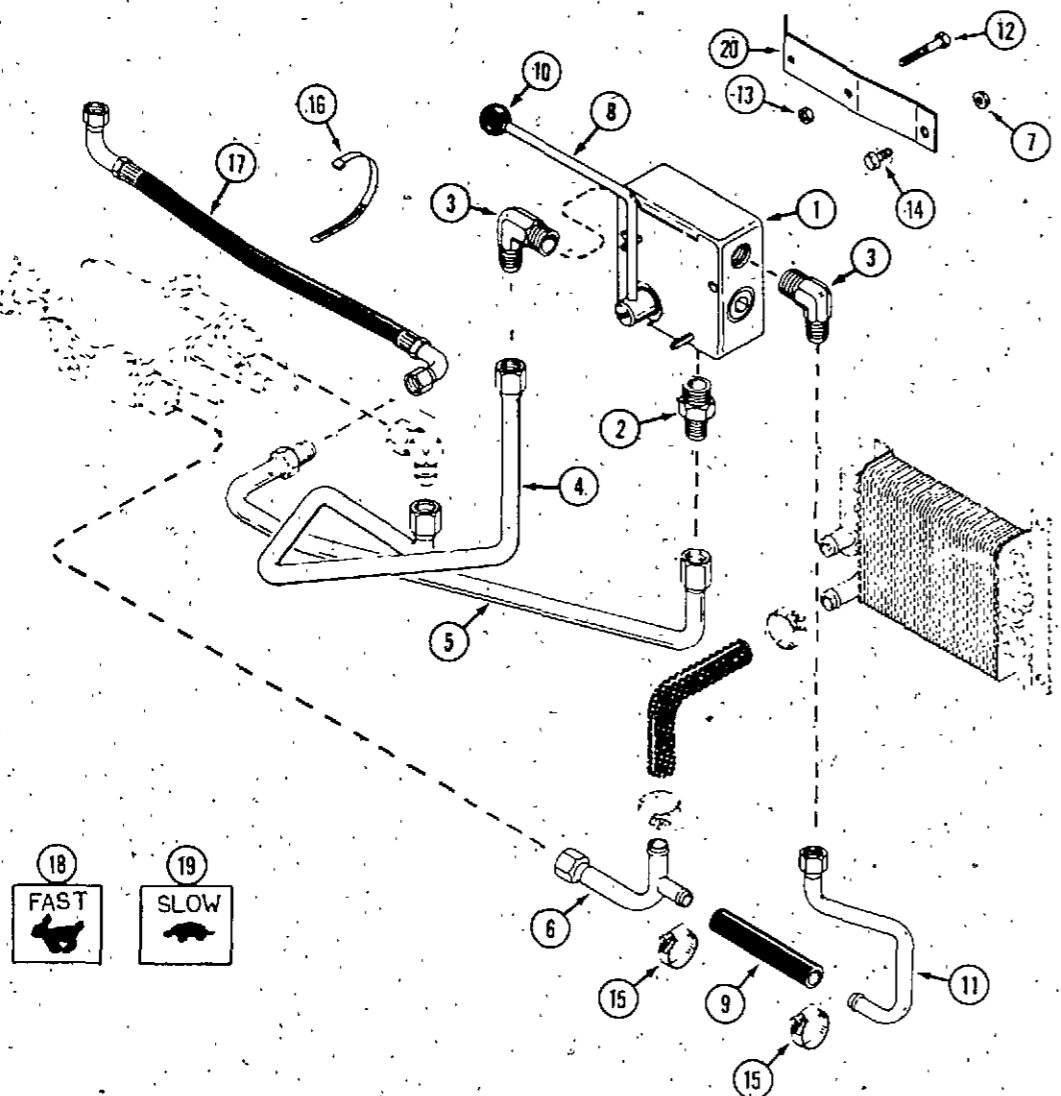

HFC34A FLOW CONTROL VALVE KIT

(Use with HP31 or HP41 PTO)

All - 3016PS, 3020PS, 4016, 4016PS, 4018PS
 3018PS - before PIN 14181900
 4020PS - before PIN 14184000

REF.	PART NO.	DESCRIPTION	REQ'D
1	C 23618	VALVE - flow control	1
2	218- 445	FITTING - 5/8" x 7/8" - 14	1
3	218- 485	FITTING - 5/8" x 7/8" - 14 90° elbow	1
4	C 36844	TUBE - flow valve to travel valve	1
5	C 36845	TUBE - flow valve to PTO valve	1
6	C 36846	TUBE - travel valve to heat exchanger	1
7	131- 934	NUT - 1/4" - 20	2
8	C 36848	LEVER - valve	1
9	C 36849	HOSE - rubber 5/8" I.D.	1
10	C 28251	KNOB - lever	1
11	C 36850	TUBE - flow valve to return	1
12	113- 15	BOLT - 1/4" - 20 x 2-1/4"	2
13	131- 1180	NUT - 1/4" - 20 lock	2
14	121- 21	BOLT - 1/4" - 20 x 1/2" flange lock	3
15	214- 254	CLAMP - hose #12 5/8" to 1-1/4"	4
16	C 22947	TIE - nylon	2
17	C 33010	HOSE - flow valve to PTO (for 3012, 3014, 3016)	1
17	C 33011	HOSE - flow valve to PTO (for 4016)	1
18	C 33220	DECAL - "fast"	1
19	C 33219	DECAL - "slow"	1
20	C 36853	BRACKET - mounting	1
	C 33221	TRIM - panel (not shown)	1
	218- 5229	FITTING - 90° swivel elbow (for 3 point hitch connections)	2
		not shown	

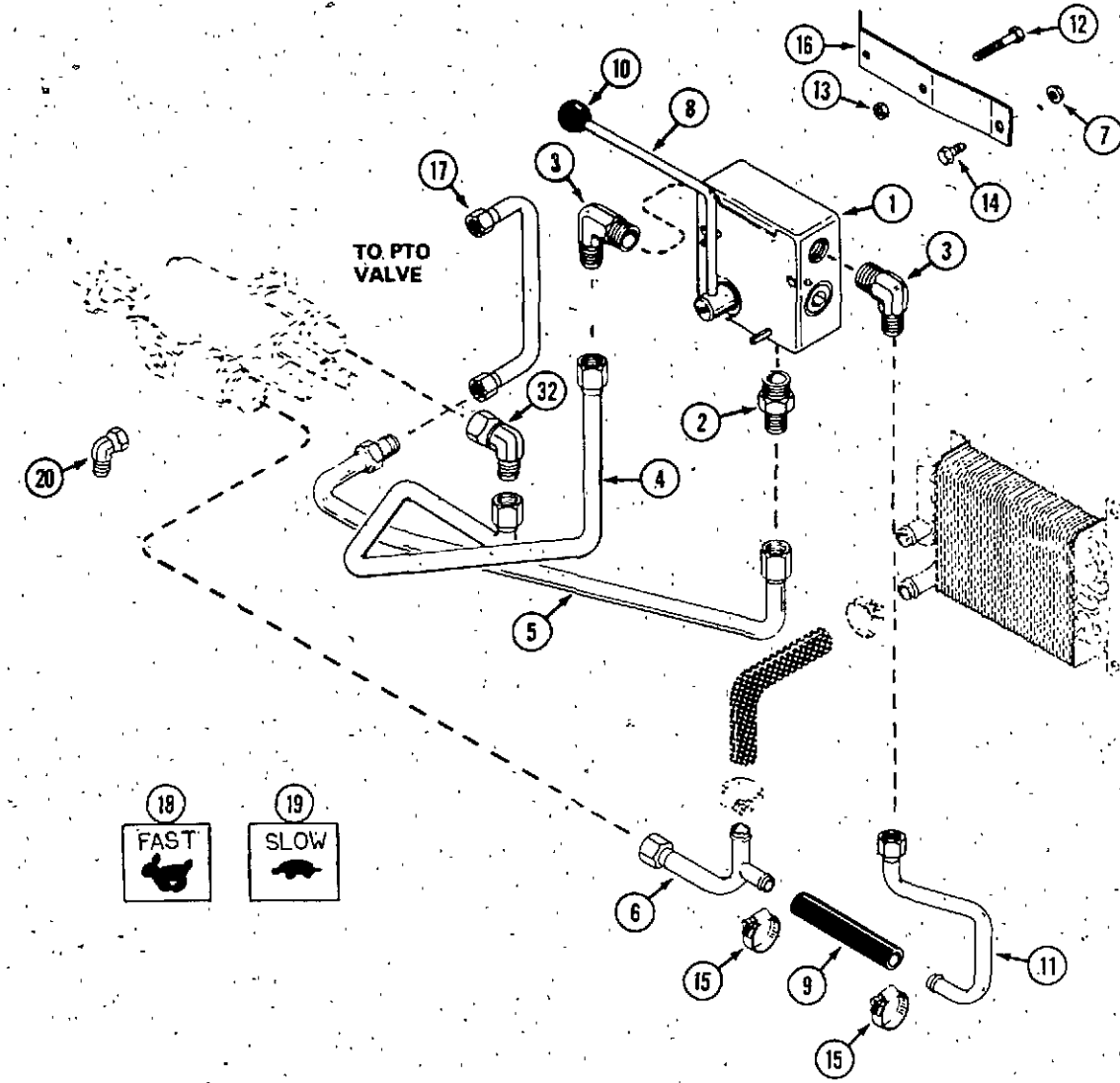

FLOW CONTROL
(use with HP34 PTO)

Use after PIN:
3018PS - 14181900
4020PS - 14184000

REF.	PART NO.	DESCRIPTION	REQ'D
1	C 23618	VALVE - flow control	1
2	218- 445	FITTING - 5/8" tube x 7/8" - 14	1
3	218- 485	FITTING - 90° 5/8" tube x 7/8" - 14	2
4	C 44986	TUBE - flow valve to travel valve	1
5	C 42531	TUBE - flow valve to PTO valve	1
6	C 36846	TUBE - travel valve to heat exchanger	1
7	131- 934	NUT - 1/4" - 20 flange lock	2
8	C 36848	LEVER - control	1
9	C 36849	HOSE - return 5/8"	1
10	C 28251	KNOB - lever	1
11	C 36850	TUBE - flow valve to return	1
12	113- 15	BOLT - 1/4 - 20 x 2-1/4"	2
13	131- 1180	NUT - lock 1/4" - 20	2
14	121- 21	BOLT - 1/4" - 20 flange lock	3
15	214- 254	CLAMP - hose	2
16	C 36853	BRACKET - mounting	1
17	C 44987	TUBE - flow valve to PTO valve (3018PS)	1
17	C 44988	TUBE - flow valve to PTO valve (4020PS)	1
18	C 33220	DECAL - "fast"	1
19	C 33219	DECAL - "slow"	1
20	218- 5229	FITTING - 90° swivel 5/16" tube (install to tee fittings on travel valve when 3 point hitch is used)	1
21	218- 5232	FITTING - 90° swivel 5/8" tube	1
	C 33221	TRIM - panel (tower side) (not shown)	1

K22 SLEEVE HITCH (3016PS, 3018PS, 3020PS)
K24 SLEEVE HITCH (4016, 4016PS, 4018PS, 4020PS)

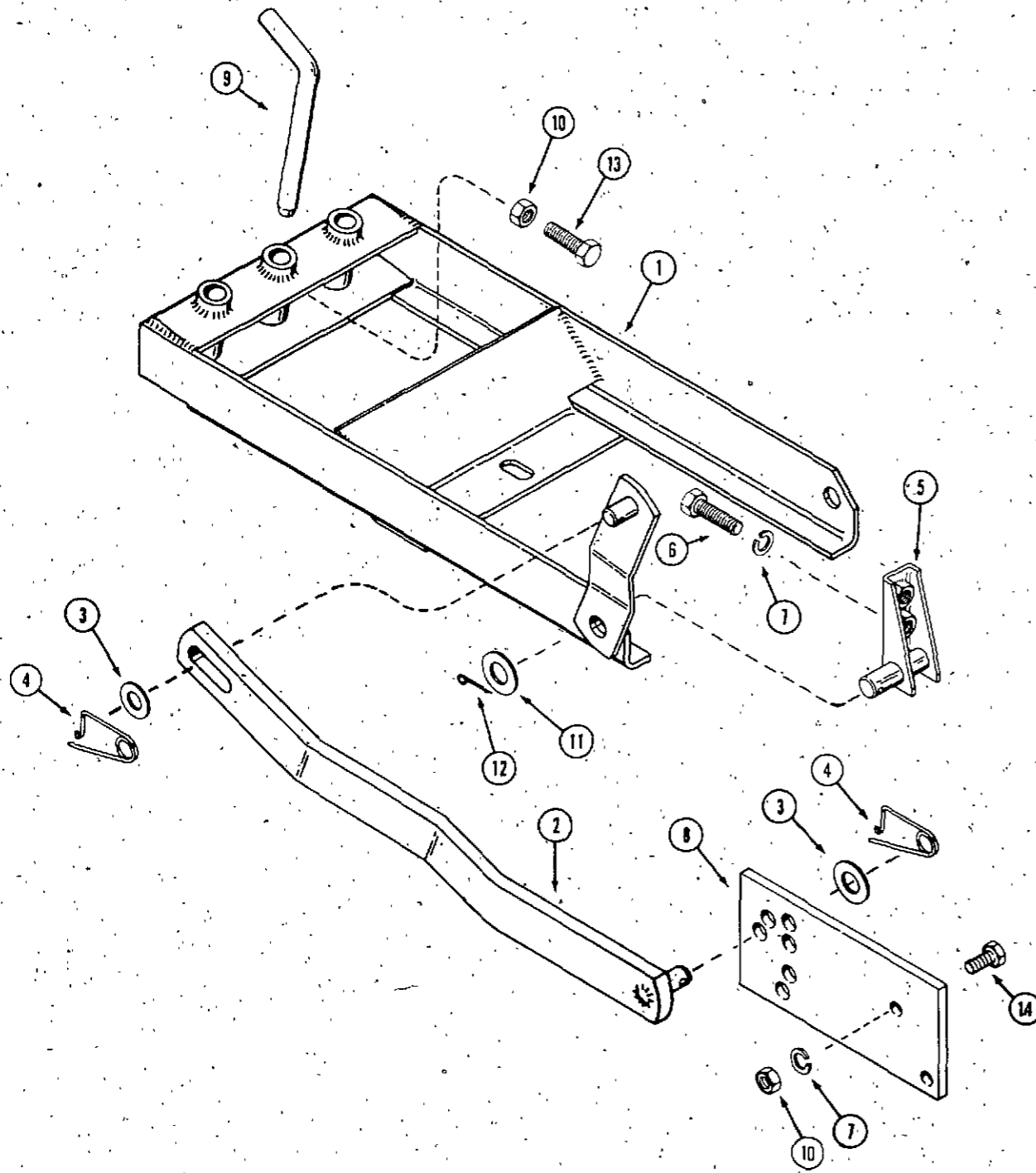

REF.	PART NO.	DESCRIPTION	REQ'D
1	NSS	HITCH FRAME ASSEMBLY (K24) shown	1
1	C 23707	HITCH FRAME ASSEMBLY (K22)	1
2	C 25371	ARM - lift	1
3	195- 541	WASHER - plain 21/32"	2
4	C 10898	PIN - retaining	2
5	C 14459	BRACKET - hitch mounting R.H. (shown)	1
5	C 25789	BRACKET - hitch mounting L.H.	1
6	113- 410	BOLT - 1/2" x 1-1/2" N.C. hex, zinc	6
7	192- 23	LOCKWASHER - 1/2" zinc	6
8	C 25382	PLATE - lift lever	1
9	C 14568	PIN - drawbar	1
10	129- 105	NUT - 1/2" N.C. hex, zinc	4
11	195- 545	WASHER - plain 3/4" zinc	2
12	132- 306	PIN - cotter 3/16" x 1-3/4"	2
13	113- 476	BOLT - 1/2" x 2" N.C. hex, zinc	2
14	113- 417	BOLT - 1/2" x 1-1/4" hex	2

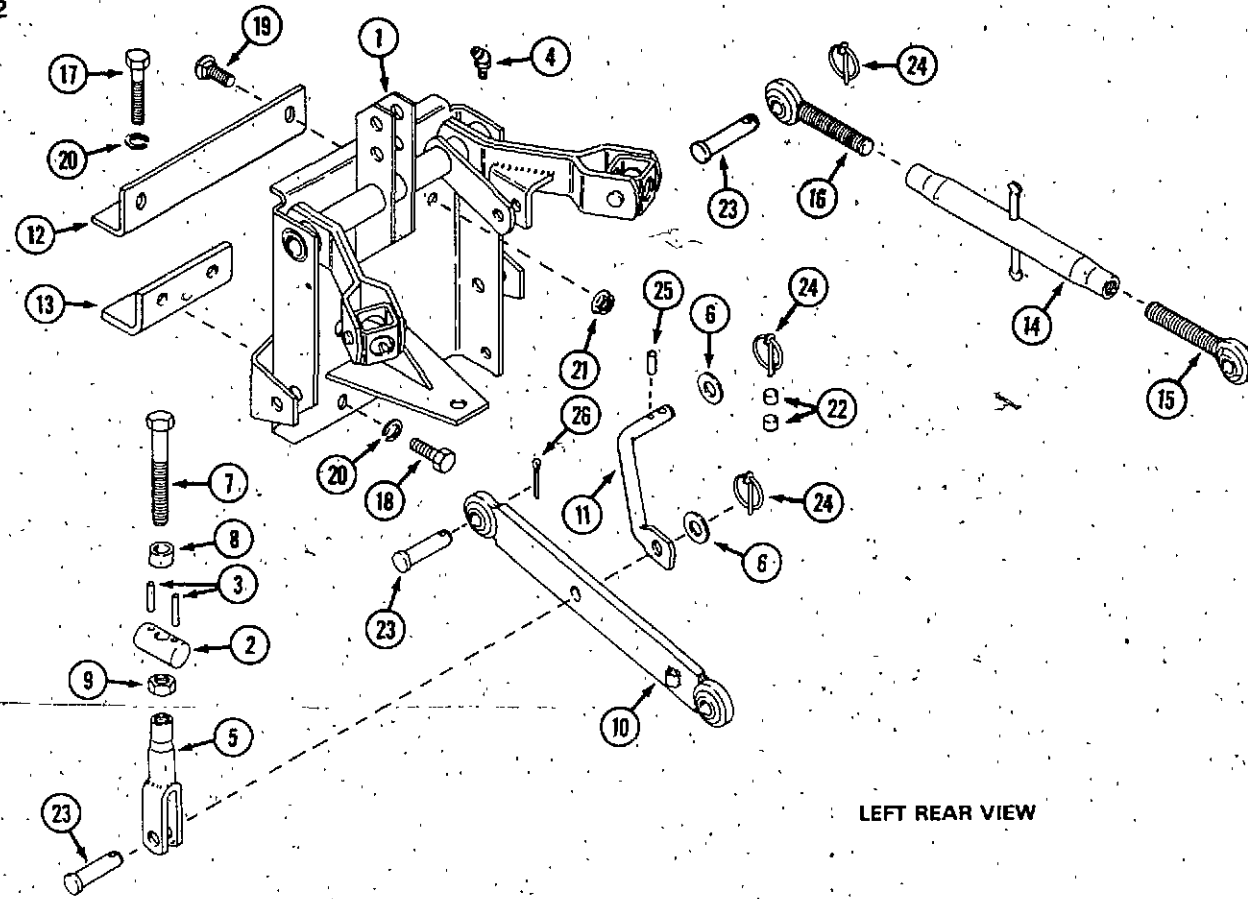

LEFT REAR VIEW

REF.	PART NO.	DESCRIPTION	REQ'D
1	C 32215	PLATE - hitch	1
2	C 32230	SWIVEL - lift link	2
3	C 32231	PIN - spiro 3/16" x 1-1/2"	4
4	219- 405	FITTING - grease	2
5	C 32428	LINK - adjusting	2
6	195- 541	WASHER - 5/8"	2
7	C 32235	BOLT - 5/8" - 11 x 5"	1
8	C 32239	SPACER - bolt	1
9	129- 107	NUT - 5/8" - 11	1
10	C 32240	ARM - lift	2
11	C 32242	ARM - stabilizer	1
12	C 32243	BRACKET - angle	1
13	C 32244	SUPPORT - angle	1
14	C 32249	TUBE - upper link	1
15	C 32426	BALLJOINT - R.H.	1
16	C 32427	BALLJOINT - L.H.	1
17	113- 447	BOLT - 1/2" - 13 x 3-1/2" (use with 3000 series tractors)	1
17	113- 426	BOLT - 1/2" - 13 x 2-3/4" (use with 4000 series tractors)	1
18	113- 417	BOLT - 1/2" - 13 x 1-1/4"	2
19	111- 517	BOLT - 1/2" - 13 x 1" carriage	2
20	192- 23	LOCKWASHER - 1/2"	3
21	131- 930	NUT - 1/2" - 13 flange lock	2
22	C 14768	SPACER - klick pin	2
23	C 14717	PIN - clevis 5/8" x 2-1/2"	6
24	C 28222	PIN - klick	6
25	138- 2073	PIN - spiral 3/16" x 1-1/4"	1
26	132- 348	PIN - cotter 1/4" x 1-1/4"	2

LEFT REAR VIEW

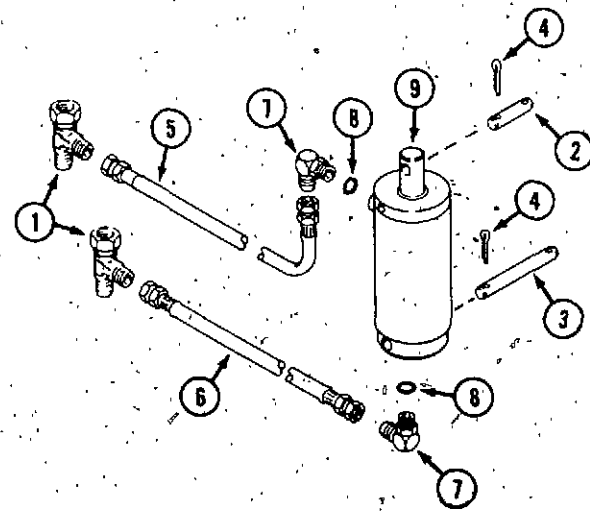

REF.	PART NO.	DESCRIPTION	REQ'D
1	218- 5479	FITTING - tee 1/2" - 20 swivel female x 1/2" - 20 male	2
2	C 28189	PIN - cylinder rod 1/2" x 2-1/8"	1
3	C 32254	PIN - cylinder foot 1/2" x 4-5/8"	1
4	132- 310	PIN - cotter 1/8" x 1"	4
5	C 32247	HOSE - hydraulic 1/4" x 33" (cylinder to forward valve port)	1
6	C 32246	HOSE - hydraulic 1/4" x 24" (cylinder to rear valve port)	1
7	218- 5104	FITTING - 90° elbow 5/16" tube x 1/2" - 20	2
8	218- 5004	O-Ring	1
9	C 32245	CYLINDER - lift	1
	C 34533	KIT - seal	1

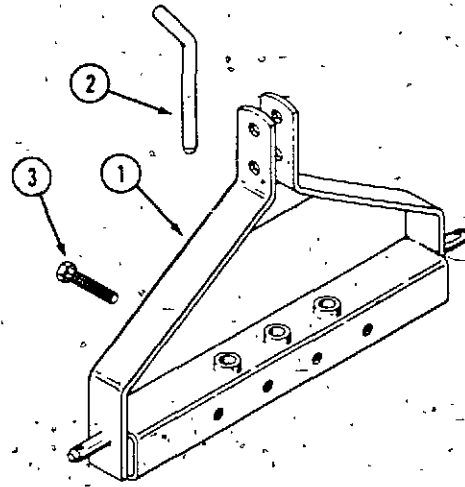

F27 HITCH ADAPTER

REF.	PART NO.	DESCRIPTION	REQ'D
1	NSS	BRACKET - hitch adapter.....	1
2	C 14568	PIN - drawbar.....	1
3	113- 425	BOLT - 1/2" x 3" N.C. hex.....	4

L11 WEIGHT KIT

1	C 25572	BRACKET - mounting, front.....	1
2	NSS	WEIGHT - 40 lb. (18 kg.).....	4
3	C 25791	BRACKET - mounting, rear, upper.....	1
4	C 25792	BRACKET - mounting, rear, lower.....	1
5	113- 417	BOLT - 1/2" - 13 x 1-1/4" hex.....	2

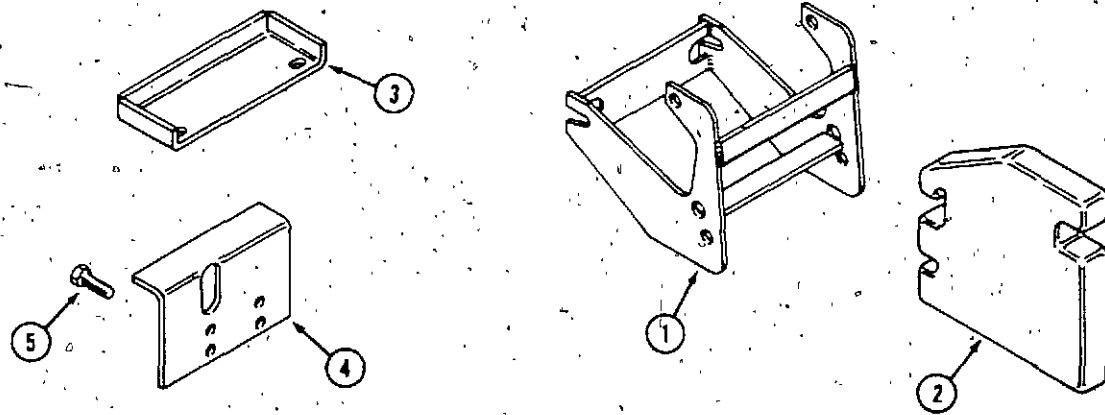

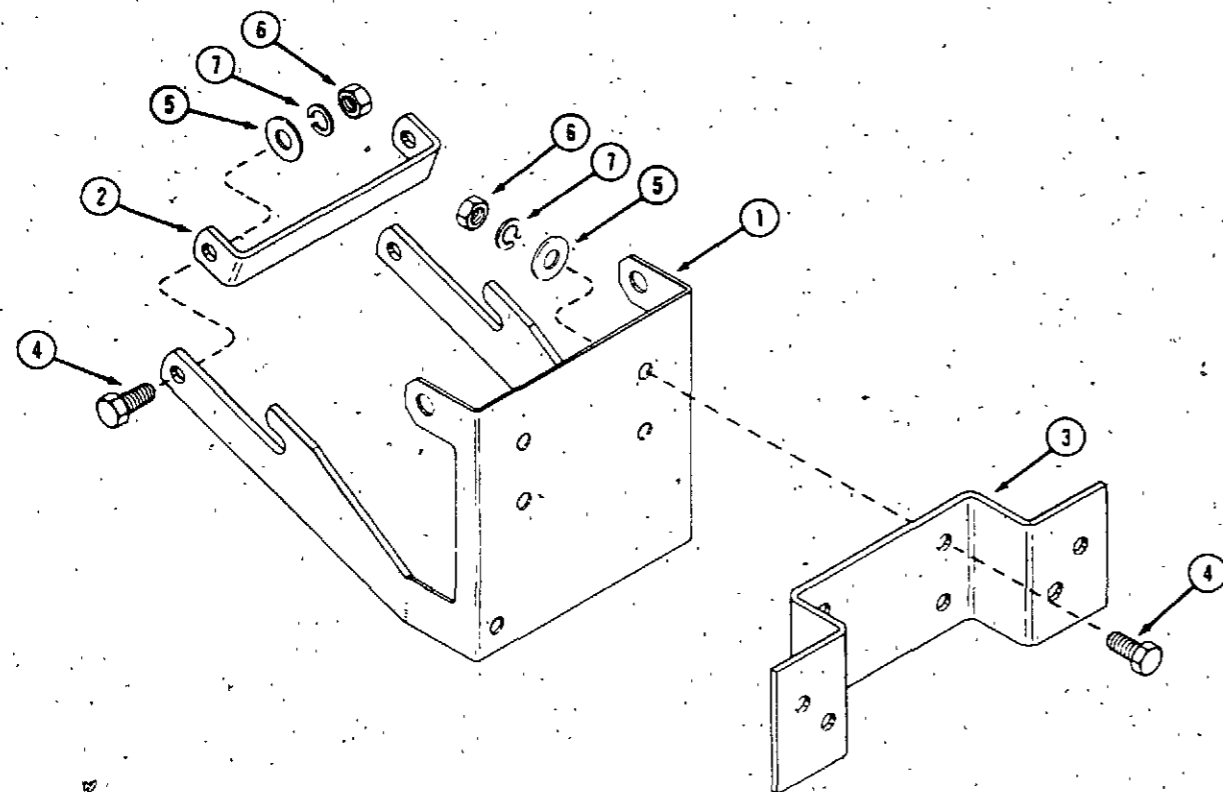

H18 FRONT END WEIGHT BRACKETS

REF.	PART NO.	DESCRIPTION	REQ'D
1	C 16581	BRACKET - mounting	1
2	C 17161	BRACE - rear	1
3	C 17162	BRACKET - weight mounting	1
4	113- 417	BOLT - 1/2" x 1-1/2" N.C. hex, zinc	6
5	195- 533	WASHER - 1/2" zinc	6
6	129- 105	NUT - 1/2" N.C. hex	6
7	192- 23	LOCKWASHER - 1/2"	6

H13 WEIGHT BOX

1	C 17859	FRAME - weight box	1
2	C 17863	BOX - weight	1
3	C 17860	SUPPORT - weight box	1
4	C 17636	PLATE - hitch	1
5	111- 371	BOLT - 3/8" x 1" round head, square neck	3
6	113- 207	BOLT - 3/8" x 1" N.C. hex	4
7	129- 103	NUT - 3/8" N.C. hex	7
8	192- 21	LOCKWASHER - 3/8"	7
9	195- 525	WASHER - 3/8"	7

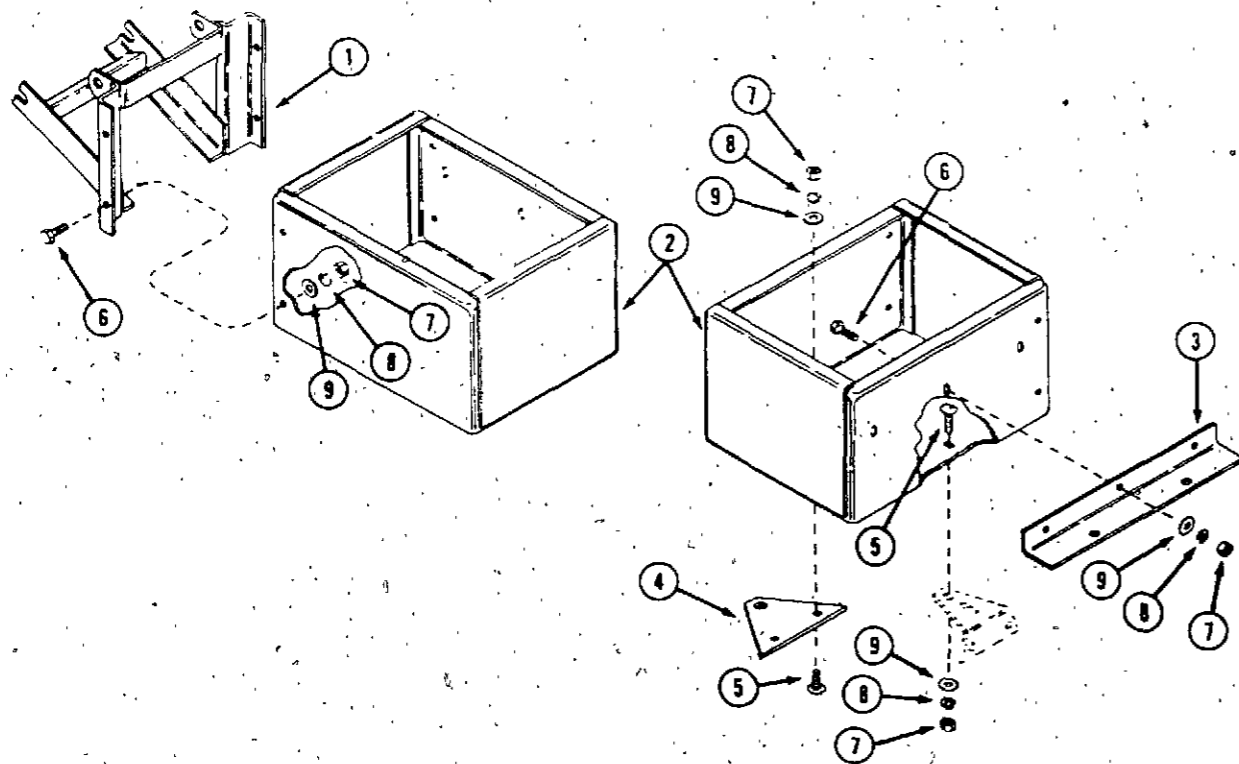

WW40 WHEEL WEIGHTS (4016, 4016PS, 4018PS, 4020PS)

REF.	PART NO.	DESCRIPTION	REQ'D
1	NSS	WEIGHT - wheel, 75 lb. (order as machinery item)	2
2	131- 1182	NUT - 1/2" N.C. hex	4
3	195- 533	WASHER - 1/2"	8
4	111- 525	BOLT - 1/2" x 6" round head, square neck	8

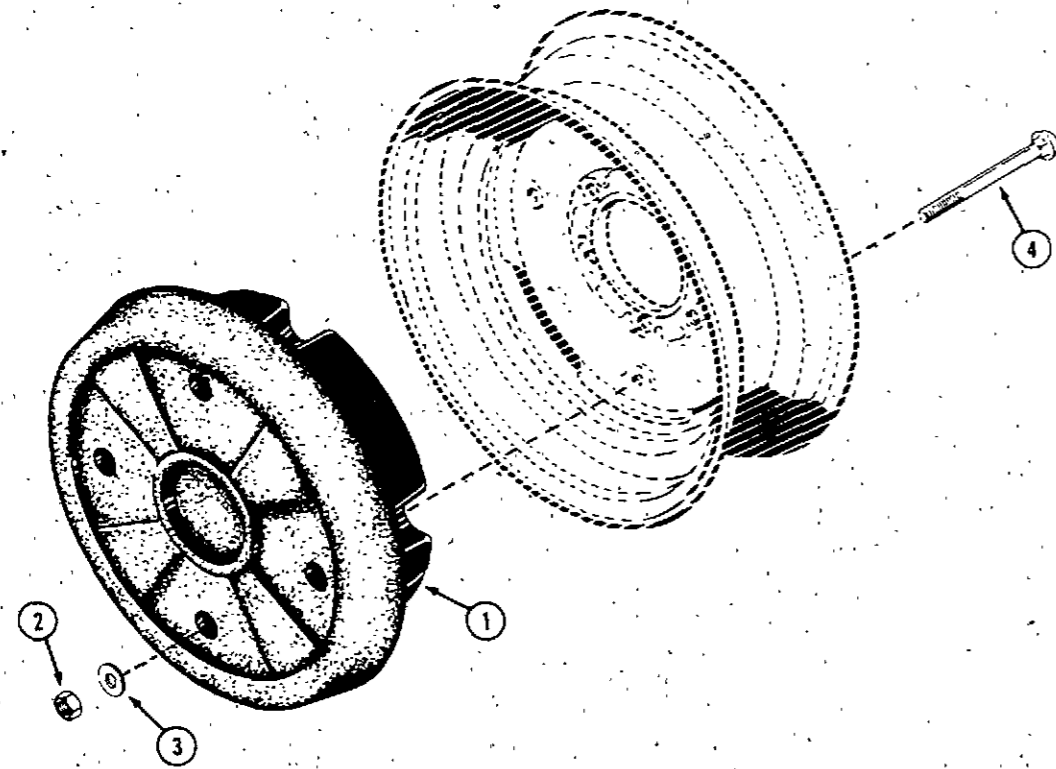

WW30 AND WW30W WHEEL WEIGHTS (3016PS, 3018PS, 3020PS)

1	NSS	WEIGHT - wheel 55 lb. (order as Machinery Item)	2
2	131- 1182	NUT - 1/2" N.C. lock	8
3	195- 533	WASHER - 1/2"	8
4	111- 521	BOLT - 1/2" x 7" carriage (WW30)	8
4	C 30545	BOLT - 1/2" - 13 x 8-1/2" (WW30W)	8

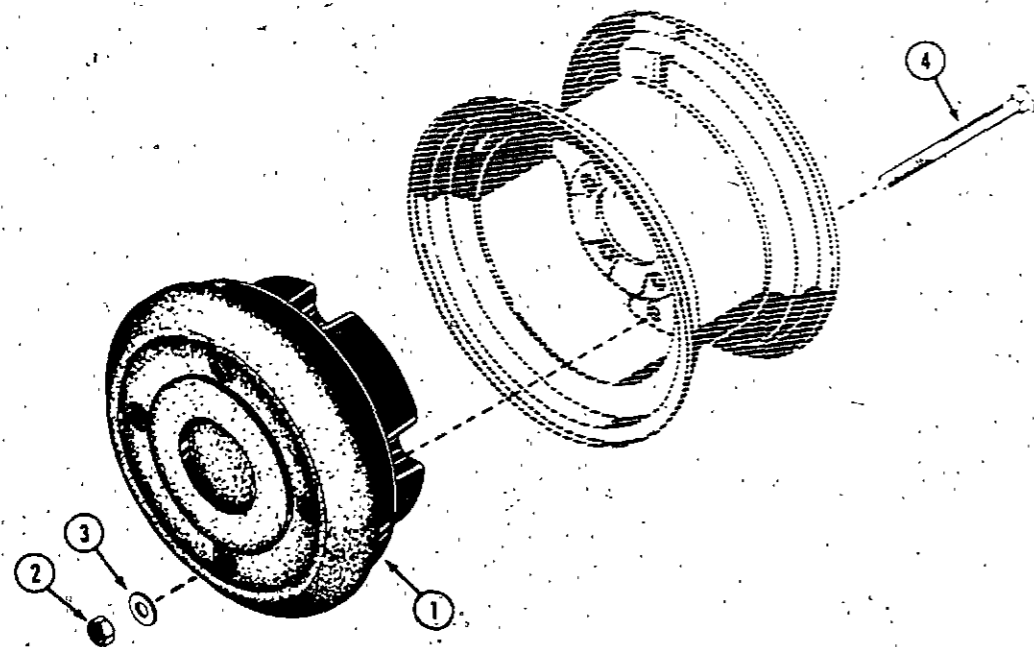

PART NO.	PAGE NO.	REF. NO.
218-5062	73	4
218-5062	75	12
218-5065	45	22
218-5065	47	22
218-5065	49	27
218-5104	83	7
218-5105	51	15
218-5107	45	4
218-5107	47	4
218-5107	49	4
218-5107	49	45
218-5107	73	3
218-5107	75	13
218-5117	45	26
218-5117	47	26
218-5117	49	26
218-5134	61	21
218-5135	51	16
218-5137	49	46
218-5154	11	39
218-5158	51	25
218-5201	73	2
218-5229	77	
218-5229	79	20
218-5232	45	8
218-5232	73	24
218-5232	79	21
218-5479	83	1
219-117	39	20
219-117	61	2
219-403	41	4
219-404	39	7
219-405	83	4
221-3	11	12
221-3	43	10
221-86	11	31
221-841	57	21
321-4767	71	3

INGERSOLL
Ingersoll Equipment Co., Inc.