



Ingersoll

**Rotary Mower
L47, M47, N47, RM44YR
Parts Catalog 8-2711**

HOME

TRACTORS

ATTACHMENTS

PAIN

GENERAL INFO

ALPHABETICAL INDEX

Axle	9
Bearings, Spindles	11-13
Belts	5-7
Blades	11-13
Bracket, Mounting	9
Decals	13
Deck	5-7
Mounting Bracket	9
Guards and Covers	5-7
Housing, Spindles	11-13
Lift Links	5-7
Pulleys	11-13
Spindles	11-13
Wheels	9

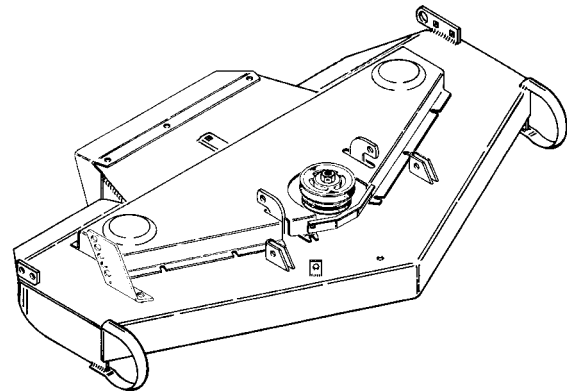

INDEX

There is an index at the front and rear of this catalog. The front index is an alphabetical index of the major groups or assemblies.

The rear index is a numerical index of the part numbers and pages on which these numbers are shown.

ILLUSTRATION

Each illustration in this catalog shows a group of parts or components. These parts and components are aligned approximately as the parts and components on your machine. Each part and component in an illustration has a reference number. These reference numbers are in a list on the page opposite of the illustration. Next to the reference number is the part number, description and required quantity of the part shown in the illustration.

UAR - "Use as required" indicates that the part quantity is variable.

NSS - "Not sold separately" indicates that the part is only available as component of an assembly or the part must be purchased locally. If the part is an assembly component, the description will be indented under the assembly description in the parts list.

O/L - "Obtain locally"

- "Footnotes" are added to a part number when more information is needed for identification. They only relate to the part numbers indicated. All orders must include the following information:

PARTS ORDERS

1. Correct part number.
2. Complete description of part or component.
3. Total quantity of each part or component.
4. Product model number.
5. All necessary product identification numbers.
6. Method for sending the parts.
7. Complete and correct address.

CATALOG REVISIONS

As the product changes, new pages will be available for your catalog. A notice will be issued.

IMPORTANT: Put all revisions into the catalog as soon as possible.

RIGHT HAND AND LEFT HAND IDENTIFICATION

The words right hand (RH) and left hand (LH) as used in this catalog indicate the direction while you are in the operator's seat in the normal operating position.

INDENTED DESCRIPTIONS

An assembly can have many components. The components of an assembly are indicated by an indented description. The quantity for an indented part is the total needed for that complete assembly. See the example.

REF.	PART NO.	DESCRIPTION	REQ'D
	C 55159	CYLINDER ASSY - rear steering	1
28	C 56208	SOCKET ASSY - rear cylinder	1
29	C 55956	PLUG - adjusting, socket assy	1
30	C 55957	SEAT- socket, ball.....	2
31	C 56210	SPRING-socket	1
32	C 56209	SEAT - socket spring	1
33	G 45175	CLAMP ASSY - socket assy	1
	16- 836	BOLT-1/2"x2-1/4" N.F. hex.....	1
34	132- 104	PIN-cotter, 3/16"x3".....	1
35	C 55889	STUD - ball, socket & cylinder	2
36	13- 410	BOLT-1/4"x5/8"N.C.,hex	4
37	92- 4	LOCK WASHER - 1/4"SAE	4

INDEX

PAINT AND OIL

PAINT

REF.	PART NO.	DESCRIPTION	REQ'D
1	C 28849	BLACK - semi - gloss, 12 oz spray (2 per carton)	1
2	C 28850	BLACK - semi - gloss, quart (2 per carton)	1
3	C 28850	BLACK - semi - gloss, heat resistant, 12 oz spray (2 per carton)	1
4	C 28484	POWER RED - gloss, 12 oz spray (2 per carton)	1
5	C 28485	POWER RED - gloss, quart (2 per carton)	1
6	C 30870	SILVER - gloss, 12 oz. spray (2 per carton).....	1
7	C 31643	POWER RED - gloss, 1 oz touch up, (1 doz. per carton)	1

OIL

1	C 32776	OIL - SAE 30, SF, quart (12 per case)	1
2	C 32777	OIL - SAE 5W20, SF, quart (12 per case)	1
3	C 32778	OIL - SAE 20W40, SF, quart (12 per case)	1

MODEL L47, M47, N47 - ALL

RM44YR - Before PIN 043050

AFTER THIS PIN

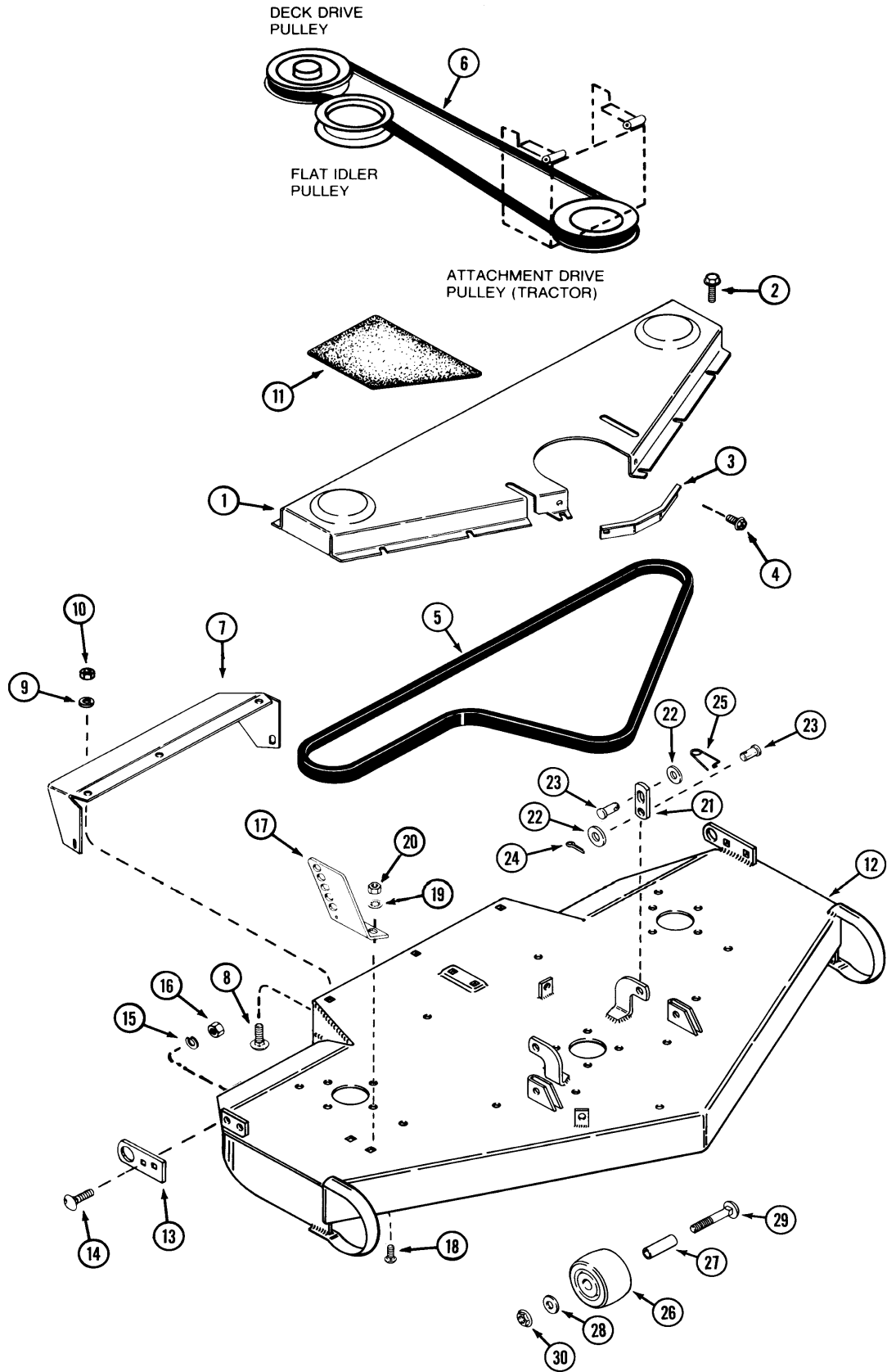

MODEL L47, M47, N47 AND RM44YR ROTARY MOWER

DECK, BELTS AND COVERS

L47, M47, N47 - ALL

RM44YR - Before PIN 043050

AFTER THIS PIN

REF.	PART NO.	DESCRIPTION	REQ'D
1	C27091	COVER - deck belt.....	1
2	187-1036	SCREW - 1/4" - 20 x 1/2" self-tapping	8
3	C27092	GUARD - deck belt.....	2
4	187-1328	SCREW - No. 8 - 18 x 3/8" self tapping	2
5	C22707	BELT - deck	1
6	C27120	BELT - drive	1
7	C27093	DEFLECTOR	1
8	111-101	BOLT - 1/4" - 20 x 5/8" carriage	5
9	192-19	LOCK WASHER - 1/4"	5
10	129-101	NUT - 1/4".....	5
11	C27094	PAD - footrest R.H. (shown).....	1
11	C27095	PAD - footrest - L.H.....	1
12	NSS *	DECK - mower	1
12	C33392 **	DECK - mower (shown)	1
13	C15560	BRACKET - axle pivot.....	1
14	111-371	BOLT - 3/8" - 16 x 1" carriage	2
15	192-21	LOCK WASHER - 3/8"	2
16	129-103	NUT - 3/8".....	2
17	C25408	BRACKET - height adjust.....	1
18	111-132	BOLT - 5/16" - 18 x 3/4" carriage	2
19	193-29	LOCK WASHER - 5/16"	2
20	129-102	NUT - 5/16".....	2
21	C27096	LINK - lift.....	2
22	195-533	WASHER - 1/2"	4
23	C10821	PIN - clevis	4
24	132-310	PIN - cotter 1/8" x 1"	2
25	C10898	PIN - safety	2
26	C31 501	ROLLER - anti-scalp	1
27	C31500	SPACER - sleeve.....	1
28	C30649	WASHER.....	1
29	131-375	BOLT - 3/8" - 16 x 3" carriage	1
30	131-938	NUT - 3/8" - 16 flange lock	1

* Before PIN 004789 use C33392, C31500, C31501
C30649, 131-375 and 131-938

** Use PIN 004789 and after

MODEL L47, M47, N47 - ALL
RM44YR - PIN 043050 AND AFTER

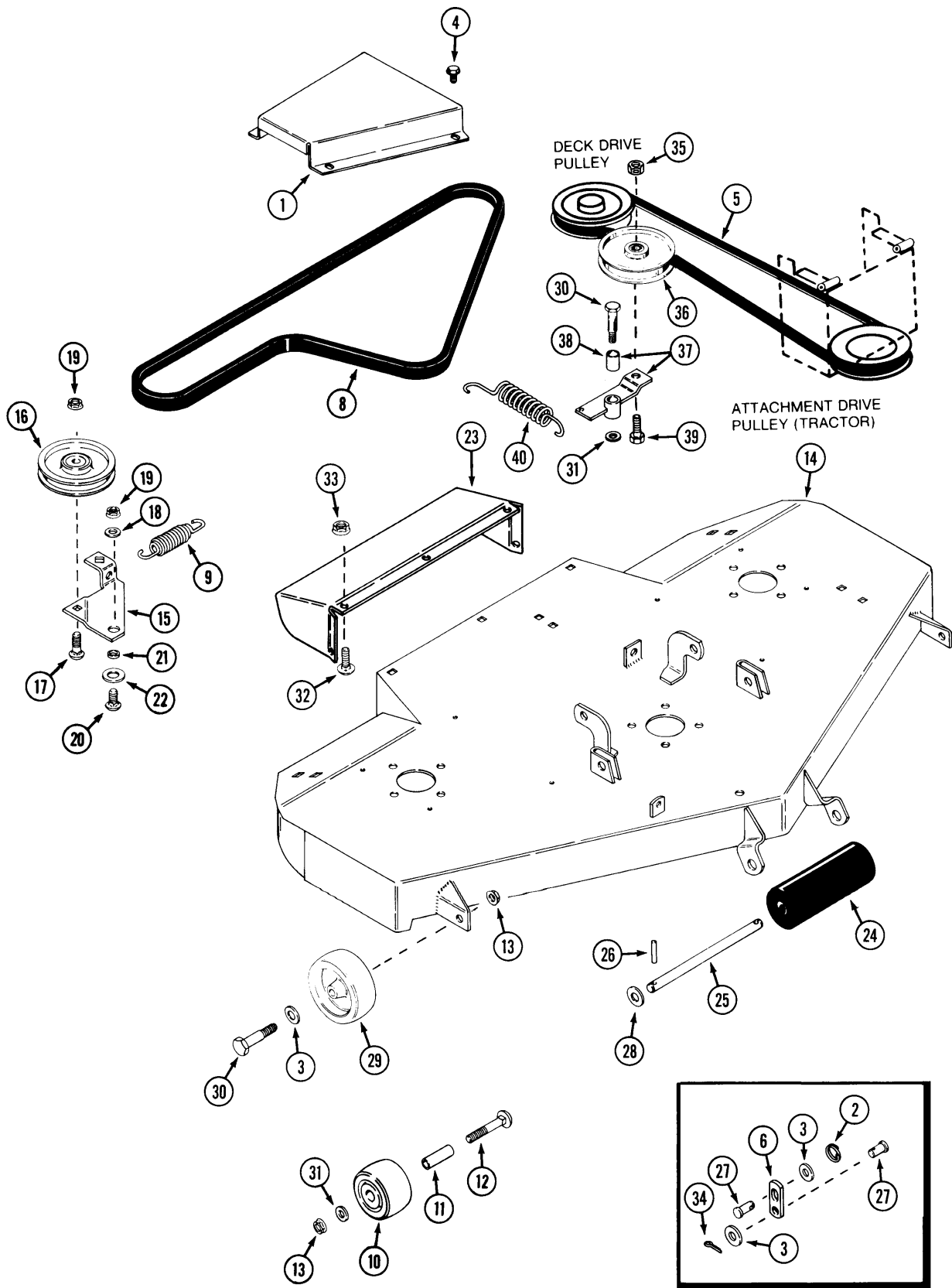

DECK, BELTS, AND BACKSIDE IDLER PULLEY

REF.	PART NO.	DESCRIPTION	REQ'D
1	C34718	COVER - deck belt L.H	1
1	C34719	COVER - deck belt R.H. (shown).....	1
2	C28105	RING - retaining	4
3	195-533	WASHER - 1/2"	4
4	187-1036	SCREW - 1/4" x 1/2" self-tapping.....	8
5	C27120	BELT - drive 50.42"	1
6	C27096	LINK - lift.....	2
8	C23949	BELT - mower deck.....	1
9	C31606	SPRING - tension.....	1
10	C31500	ROLLER - anti-scalp, rear.....	2
11	C31 501	SPACER - sleeve	2
12	111-375	BOLT - 3/8" - 16 x 3" carriage	1
13	131-938	NUT - 3/8" - 16 flange lock	3
14	C36862	DECK - mower	1
15	C31608	PLATE - idler.....	1
16	C12251	PULLEY - backside idler	1
17	111-366	BOLT - 3/8" - 16 x 1-1/4" carriage.....	1
18	195-525	WASHER - 3/8"	1
19	131-1352	NUT - 3/8" - 16 flange lock.....	2
20	111-371	BOLT - 3/8" 16 x 1" carriage	1
21	C14768	SPACER - sleeve	1
22	195-105	WASHER - 1/2"	1
23	C27093	DEFLECTOR - chute	1
24	C28977	ROLLER - 7", front	1
25	C26405	SHAFT - roller	1
26	138-106	PIN - roll 3/16" x 2-1/2"	1
27	C10821	PIN - clevis 1/2" x 1"	4
28	195-541	WASHER - 5/8"	1
29	C33709	WHEEL - anti-scalp, front.....	2
30	C16745	BOLT - shoulder	3
31	C30649	WASHER - spacer	2
32	111-101	BOLT - 1/4" - 20 x 5/8" carriage	5
33	131-934	NUT - 1/4" - 20 flange	5
34	132-310	PIN - cotter	2
35	131-1182	NUT- 1/2" lock	1
36	C26090	PULLEY - idler, drive belt.....	1
37	C27109	IDLER ARM ASSEMBLY	1
38	C16714	BUSHING - sleeve.....	1
39	113-410	BOLT - 1/2" - 13 x 1-1/2"	1
40	C24321	SPRING - idler, drive belt.....	1

INDEX

MODEL L47, M47, N47 AND RM44YR ROTARY MOWER AXLE AND MOUNTING BRACKETS
L47, M47, N47 - ALL
RM44YR - before PIN 043050

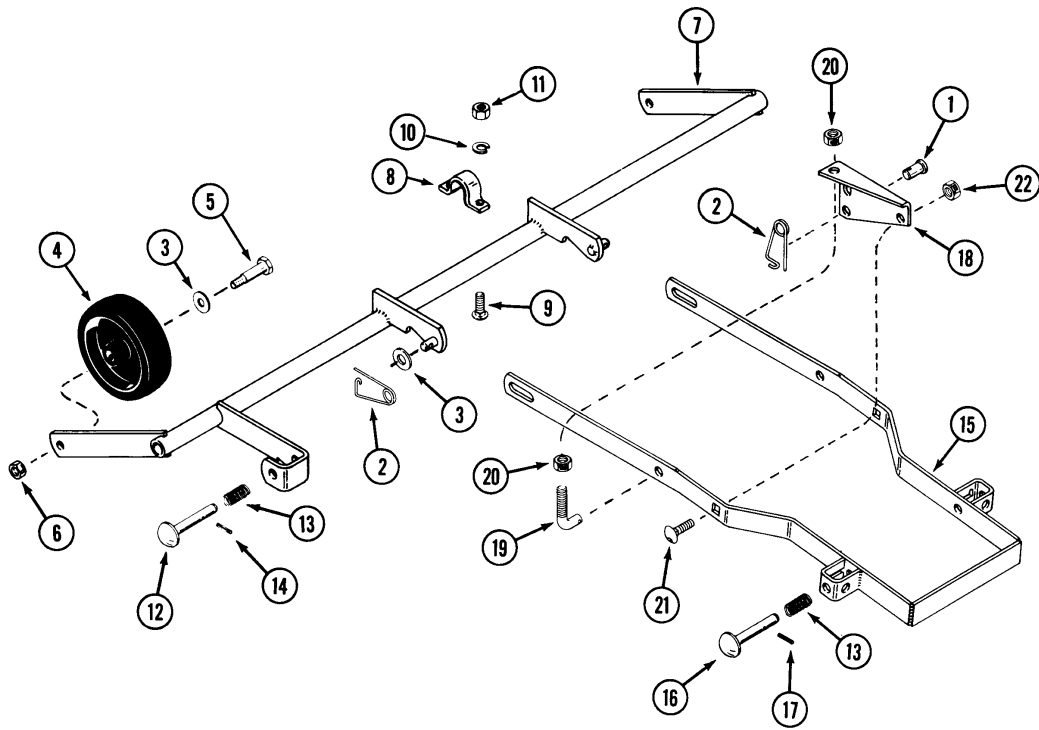

INDEX

AXLE AND MOUNTING BRACKETS
RM44YR - PIN 043050 and after

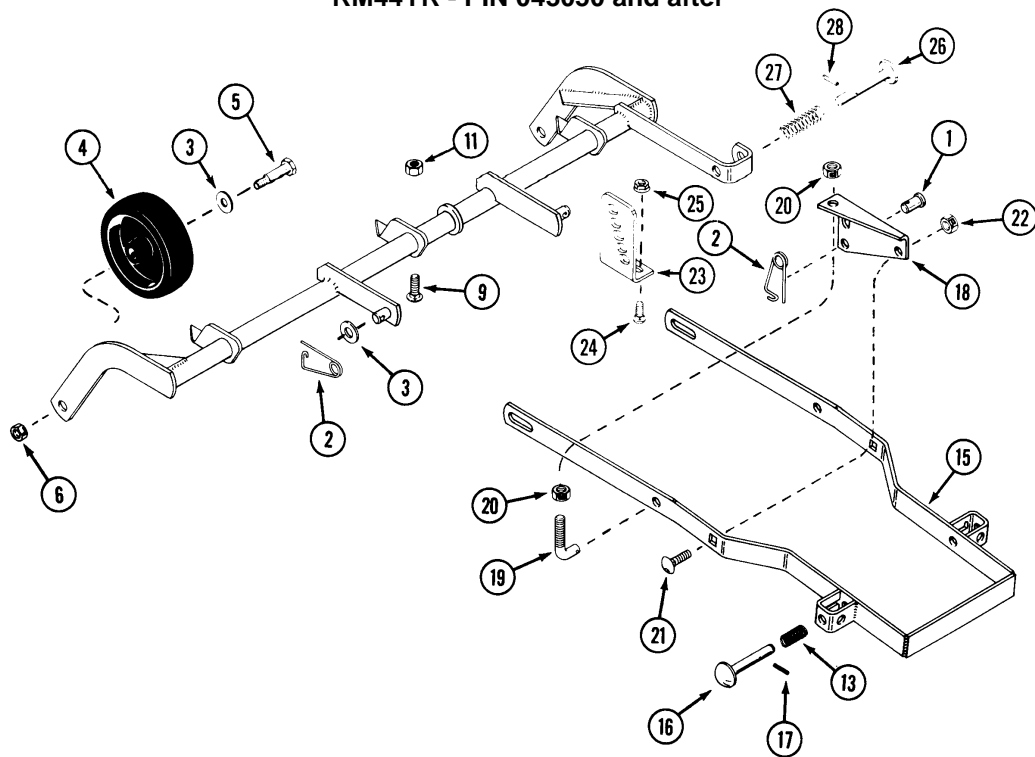

INDEX**MODEL L47, M47, N47 AND RM44YR ROTARY MOWER****AXLE AND MOUNTING BRACKETS****L47, M47, N47 - ALL****RM44YR - before PIN 043050**

REF.	PART NO.	DESCRIPTION	REQ'D
1	C10821	PIN - clevis	2
2	C10898	PIN - safety	4
3	195-533	WASHER - 1/2"	4
4	C26736	WHEEL - gauge	2
5	C16745	BOLT - shoulder	2
6	131-1181	NUT - 3/8" - 16 lock	2
7	C27106	AXLE - rear	1
8	C14932	BRACKET - axle mounting.....	1
9	111-101	BOLT - 1/4" 20 x 3/4" carriage	2
10	192-19	LOCK WASHER - 1/4"	2
11	129-101	NUT - 1/4" -20	2
12	C20005	PIN - retaining	1
13	C10482	SPRING.....	2
14	138-96	PIN - roll 3/16" x 1"	1
15	C27115	FRAME - mounting.....	1
16	C15278	PIN - retaining	2
17	138-99	PIN - roll 3/16" x 1-3/8"	2
18	C27118	BRACKET - suspension adjust R.H. (shown).....	1
18	C27119	BRACKET - suspension adjust L.H	1
19	C19088	BOLT - "J" suspension adjust.....	2
20	131-1182	NUT - 1/2" - 13 lock.....	4
21	111-517	BOLT - 1/2" - 13 x 1" carriage	2
22	131-1308	NUT - 1/2" - 13 lock.....	2

INDEX**AXLE AND MOUNTING BRACKETS****RM44YR - PIN 043050 and after**

REF.	PART NO.	DESCRIPTION	REQ'D
1	C10821	PIN - clevis	2
2	C10898	PIN - safety	4
3	195-541	WASHER - 1/2"	4
4	C31498	WHEEL - gauge	2
5	C31499	BOLT - shoulder	2
6	131-930	NUT - 3/8" - flange lock	2
7	C36867	AXLE - rear	1
8	C14932	BRACKET - axle mounting.....	1
9	111-340	BOLT - 3/8" - 16 x 3/4" carriage (shown)	4
9	121-228	BOLT - 3/8" - 16 x 3/4" flange lock (center support)	2
10	192-19	LOCK WASHER - 1/4"	2
11	131-938	NUT - 3/8" - 16 flange lock	6
12	C20005	PIN - retaining	1
13	C10482	SPRING.....	2
14	138- 96	PIN - roll 3/16" x 1"	1
15	C36871	FRAME - mounting.....	1
16	C15278	PIN - retaining	2
17	138-99	PIN - roll 3/16" x 1"	2
18	C27118	BRACKET - suspension adjust R.H. (shown).....	1
18	C27119	BRACKET - suspension adjust L.H	1
19	C19088	BOLT - "J" suspension adjust.....	2
20	131-1182	NUT - 1/2" - 13 lock.....	4
21	111-517	BOLT - 1/2" - 13 x 1" carriage	2
22	131-1308	NUT - 1/2" - 13 lock.....	2
23	C34734	BRACKET - height adjust.....	1
24	111-132	BOLT - 5/16" - 18 x 3/4"	2
25	131-911	NUT - 5/16" - 18 flange	2
26	C20005	PIN - locking.....	1
27	C10482	SPRING - compression.....	1
28	138-96	PIN - roll 3/16" x 1"	1

MODEL L47, M47, N47 AND RM44YR ROTARY MOWER

PULLEYS, BLADES AND SPINDLES
L47, M47, N47 - ALL
RM44YR - before PIN 043050

AFTER THIS PIN

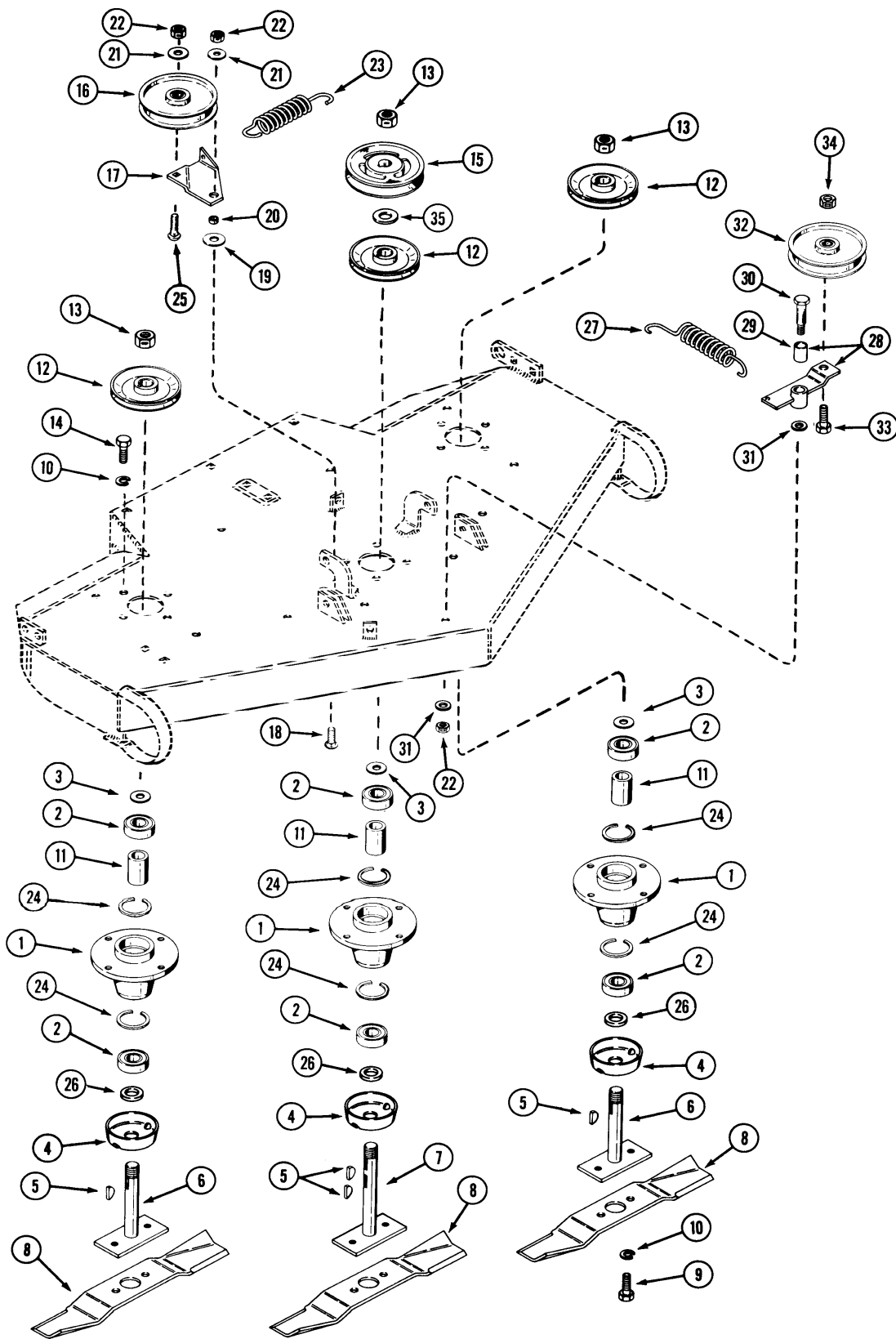

MODEL L47, M47, N47 AND RM44YR ROTARY MOWER

PULLEYS, BLADES AND SPINDLES
L47, M47, N47 - ALL
RM44YR - before PIN 043050

AFTER THIS PIN

REF.	PART NO.	DESCRIPTION	REQ'D
1	C17666	HOUSING - mower spindle (also requires (2) C16516 retainers).....	3
2	C28971	BEARING - spindle	6
3	C28972	WASHER - bearing seal.....	3
4	C25543	SHIELD - bearing	3
5	126-19	KEY - spindle, #11 Woodruff.....	4
6	C15763	SPINDLE - outboard	2
7	C1 5604	SPINDLE - center.....	1
8	C27113	BLADE - 15-1/2".....	3
9	113-206	BOLT - 3/8" x 5/8" NC hex (grade 5).....	6
10	192-21	LOCK WASHER - 3/8"	18
11	C10810	SPACER - bearing	3
12	C21 581	PULLEY - spindle.....	3
13	131-1331	NUT - jam lock 3/4" NF hex.....	3
14	113-206	BOLT - 3/8" x 3/4" NC hex	12
15	C15615	PULLEY - drive	1
16	C12251	PULLEY - deck idler.....	1
17	C27108	BRACKET - idler	1
18	111-371	BOLT - 3/8" x 1" carriage, short neck.....	1
19	195-105	WASHER - 1/2" ZP	1
20	C14768	SPACER - idler bracket.....	1
21	195-525	WASHER - 3/8" ZP	2
22	131-1181	NUT - lock 3/8" NC hex	3
23	C14482	SPRING - idler, deck belt	1
24	C16516	RING - retainer.....	6
25	111-366	BOLT - 3/8" x 1-1/4" carriage, short neck	1
26	C25541	SPACER - spindle.....	3
27	C24321	SPRING - idler, drive belt.....	1
28	C27109	IDLER ARM ASSEMBLY	1
29	C16714	BUSHING - sleeve	1
30	C16745	BOLT - shoulder	1
31	C30649	WASHER - 3/8"	2
32	C26090	PULLEY - idler, drive belt.....	1
33	113-410	BOLT - 1/2" - 13 x 1-1/2"	1
35	C28226	WASHER - spacer	1

SPINDLES AND BLADES
RM44YR - PIN 043050 and after

BEFORE THIS PIN

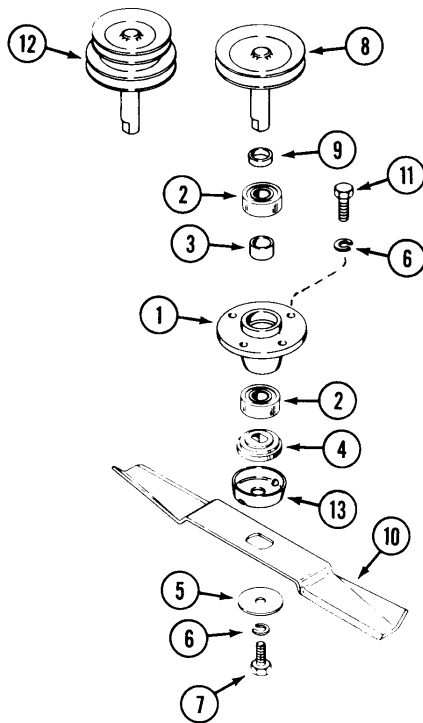

⚠ DANGER

SPINNING BLADE

KEEP CLEAR
CONTACT CAN INJURE

NO STEP

1

DECK DRIVE PULLEY
FLAT IDLER PULLEY
ATTACHMENT DRIVE PULLEY (TRACTOR)

- 1) SHUT OFF ENGINE, REMOVE KEY, AND WAIT FOR ALL MOTION TO STOP BEFORE INSTALLING BELT
- 2) PLACE ATTACHMENT DRIVE IN DISENGAGEMENT POSITION
- 3) POSITION MOWER CUTTING HEIGHT TO LOW
- 4) INSTALL BELT TO DECK PULLEY AND IDLER PULLEY AS SHOWN. ROTATE IDLER PIVOT ARM AND SECURE BELT TO ATTACHMENT DRIVE PULLEY
- 5) DOUBLE CHECK THAT THE BELT IS PROPERLY SEATED IN EACH PULLEY-NO TWIST IN BELT

CA C27090

⚠ DANGER

FLYING DEBRIS

OPERATE MOWER ONLY WITH CHUTE EXTENSION OR GRASS CATCHER

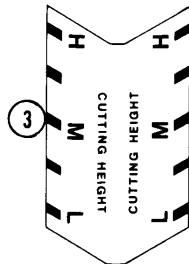

⚠ WARNING

FLYING DEBRIS

OPERATE MOWER ONLY WITH DISCHARGE CHUTE GUARD/COVER OR COMPLETE GRASS CATCHER IN PLACE. DEBRIS MAY CAUSE INJURY

MODEL L47, M47, N47 AND RM44YR ROTARY MOWER

SPINDLES AND BLADES
RM44YR - PIN 043050 and after **BEFORE THIS PIN**

REF.	PART NO.	DESCRIPTION	REQ'D
1	NSS	HOUSING – spindle (use C17666 and (2) C16516).....	3
2	C28971	BEARING - spindle	6
3	C10810	SPACER - bearing	3
4	C25542	ADAPTER - blade	3
5	C31452	WASHER - 3/8" x 2"	3
6	192-21	LOCK WASHER - 3/8"	15
7	113-209	BOLT - 3/8" - 16 x 1-1/2" (use 35 ft lb. or torque)	3
8	C31566	SPINDLE - outboard	2
9	C29431	SPACER - spindle	3
10	C31571	BLADE - 15-1/2"	3
11	113-206	BOLT - 3/8" - 16 x 3/4" (use 15 ft lb. of torque).....	12
12	C36868	SPINDLE - center.....	1
13	C25544	SHIELD - bearing	3

DECALS

1	C27090	DECAL - drive belt	1
2	C12519	DECAL - "No Step".....	1
3	321-6210	DECAL - cutting height.....	1
4	C31087	DECAL - "Spinning Blade"	2
5	NSS	DECAL - "Flying Debris" (use C31086).....	1
6	C31086	DECAL - "Warning" (RM44YR)	1