

**CASE MODEL 210  
COMPACT TRACTOR  
S/N 9686282 AND AFTER**

**U.S. PRICE 75 CENTS**

**Parts Catalog No. 1310**

Hi-Liter 2500 7-75

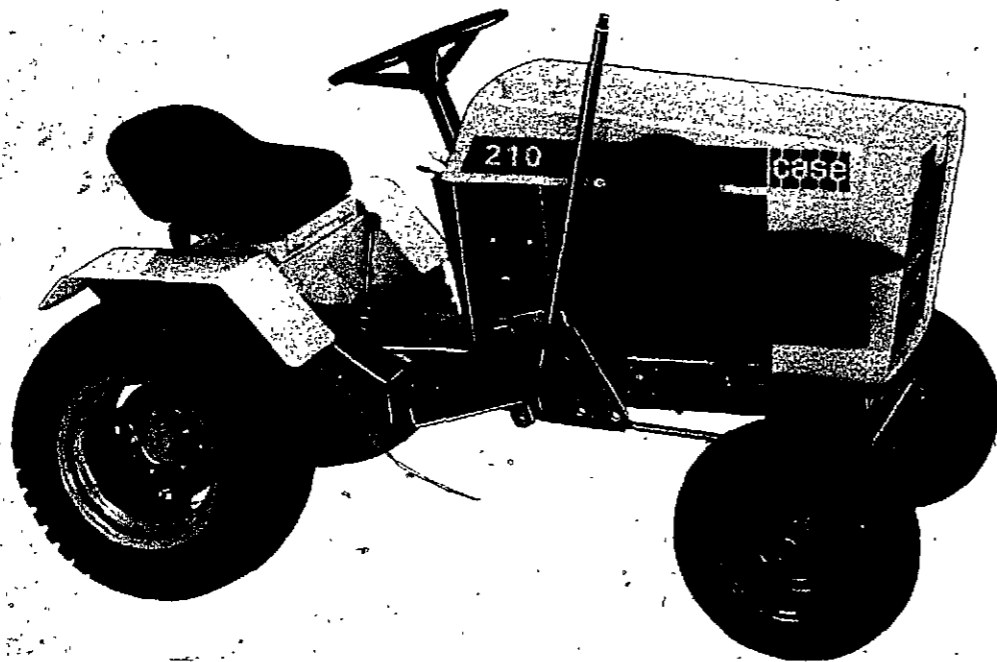

**ALPHABETICAL INDEX**

**ENGINE SECTION**

	PAGE	GRID		PAGE	GRID
Air Cleaner	5	A6	Filter, Breather	7	A8
Battery	49	D8	Flywheel	11	A12
Belt, Starter-Generator	15	B2	Fuel Pump	15-17	B2-B4
Breather, Crankcase	7	A8	Fuel Strainer	15	B2
Camshaft	7	A8	Fuel System	15	B2
Carburetor	15-17	B2-B4	Gasket Kits	13	A14
Connecting Rod	9	A10	Governor	11	A12
Crankshaft	9	A10	Muffler	5	A6
Cylinder Block	11	A12	Oil Pan	11	A12
Cylinder Head	11	A12	Piston	9	A10
Electrical System	49-51	D8-D10	Pulley, Clutch	23	B10
Engine Block & Attaching Parts	11	A12	Spark Plug	49	D8
Engine Mounts	19	B6	Starter-Generator	45-47	D4-D6
Exhaust System	5	A6	Tank, Fuel	15	B2
			Throttle Linkage	19	B6
			Valves	7	A8

**BASIC TRACTOR SECTION**

	PAGE	GRID		PAGE	GRID
Axle, Front	29	C2	Model J21 Sleeve Hitch	55	D14
Axle, Rear	39-41	C12-C14	Model H13 Weight Box	59	E4
Baffles & Shrouds	15	B2	Model H18 Counterweight		
Brakes	37	C10	Brackets	59	E4
Decals	53	D12	Pulleys, Belts and Idlers	33-35	C6-C8
Electrical System	49-51	D8-D10	Pulley Clutch	21-23	B8-B10
Fenders	27	B14	Seat, Operator's	27	B14
Frame	25	B12	Steering Wheel & Gear	31	C4
Grille	25	B12	Tail Lamp	49	D8
Hitch	43	D2	Tool Box	27	B14
Hood	25	B12	Transmission	39-41	C12-C14
Implement Lift Lever	43	D2	Wheels, Front & Rear	29	C2
Model D8 Wheel Weights	57	E2			

# GENERAL INFORMATION

## Indexes

This parts Catalog is arranged for easy identification of Genuine CASE Service Parts. An alphabetical index is provided at the front of this Catalog to locate the major groups or assemblies. A numerical index at the rear of the Catalog gives the part numbers and the pages on which they are described.

## Illustrations

All parts are illustrated in "Exploded Views" which show the individual parts in their normal relationship to each other. Reference numbers are used in the illustrations. These numbers correspond to those in the "Reference Number" column and are followed by the part number, description and quantity required.

## Orders

Orders should plainly specify correct part number, full description, quantity required, machine model and engine model, machine and engine serial numbers, method of shipment and shipping address.

## Changes

When changes to the machine make it necessary, revised pages for this book will be issued. The revised pages will be issued with the same page number as those they replace and the "issue" number and date will be advanced.

It is imperative that revised Parts Book pages be inserted into their respective Parts Books as soon as received. Failure to do so will lead to confusion and defeat the purpose of the book.

## Indented Description

Indented parts in the descriptive list are a part of the preceding assembly or sub-assembly. The quantity shown in the "Number Required" column is the number of parts used on a machine except where parts are indented in descriptive list. In this case the quantity shown is the number required for the preceding assembly or sub-assembly.

REF.	PART NO.	DESCRIPTION	REQ'D
	A 55159	CYLINDER ASSY - rear steering	1
28	A 56208	SOCKET ASSY - rear cylinder	1
29	A 55956	PLUG - adjusting, socket assy	1
30	A 55957	SEAT - socket ball	2
31	A 56210	SPRING - socket	1
32	A 56209	SEAT - socket spring	1
33	G 45175	CLAMP ASSY - socket assy	1
	16- 836	BOLT - 1/2" x 2-1/4" N.F. hex.	1
34	132- 104	PIN - cotter, 3/16" x 3"	1
35	A 55889	STUD - ball, socket & cylinder	2
36	13- 410	BOLT - 1/4" x 5/8" N.C., hex.	4
37	92- 4	LOCKWASHER - 1/4" SAE	4

## Terms "Right Hand" and "Left Hand"

"Right Hand" and "Left Hand" sides of this machine are determined by standing at the rear of the unit and facing in the direction of forward travel.

## CASE MODEL 210 COMPACT TRACTOR



TRACTOR MODEL AND SERIAL NUMBER

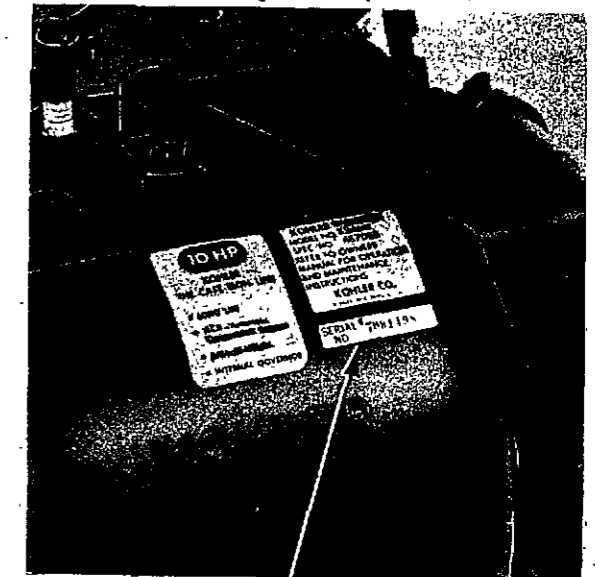

ENGINE MODEL, SERIAL AND SPECIFICATION NUMBER

TRACTOR MODEL DESIGNATION	ENGINE MODEL DESIGNATION
210 TRACTOR	K-241-A C19026 ENGINE SPEC. 46708D

## SERIAL NUMBERS

When using this catalog, notice the reference to serial numbers of various components noted here and listed in the "description" copy. By referring to correct serial numbers, proper parts identification will be assured.

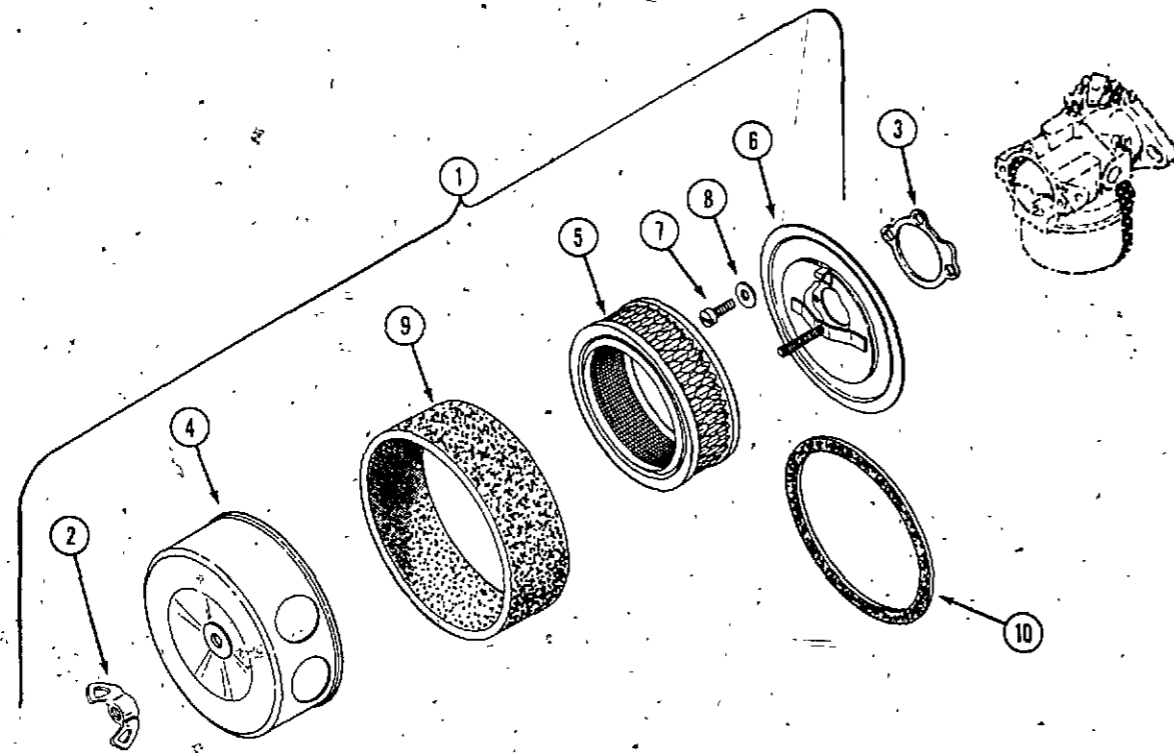

**AIR CLEANER**

REF.	PART NO.	DESCRIPTION	REQ'D
1	KO 237895	AIR CLEANER ASSEMBLY (includes items 4, 6 and 10)	1
2	129- 409	NUT - wing 3/8" NC	1
3	KO 275341	GASKET - air horn	1
4	NSS	COVER - air cleaner (Order KO2037895)	1
5	A 70090	ELEMENT - air cleaner	1
6	NSS	BASE - air cleaner (Order KO237895)	1
7	177- 94	SCREW - fillister head 10-32 x 5/16"	3
8	195- 521	WASHER - plain 3/16"	3
9	KO 237421	PRE-CLEANER	1
10	KO 237423	GASKET - cover, air cleaner	1

**EXHAUST SYSTEM**

1	C 19053	MUFFLER - exhaust (includes clamp)	1
2	C 19213	PIPE - engine exhaust	1
3	113- 207	BOLT - 3/8" x 1" NC hex	1
4	195- 525	WASHER - 3/8" plain	1
5	192- 21	LOCKWASHER - 3/8"	1
6	129- 103	NUT - 3/8" NC hex	1
7	111- 256	BOLT - 5/16" x 1-1/4" round head square neck NC	1
8	C 19449	CLAMP - muffler (includes hardware)	1
9	192- 20	LOCKWASHER - 5/16"	1
10	129- 102	NUT - 5/16" NC hex	1

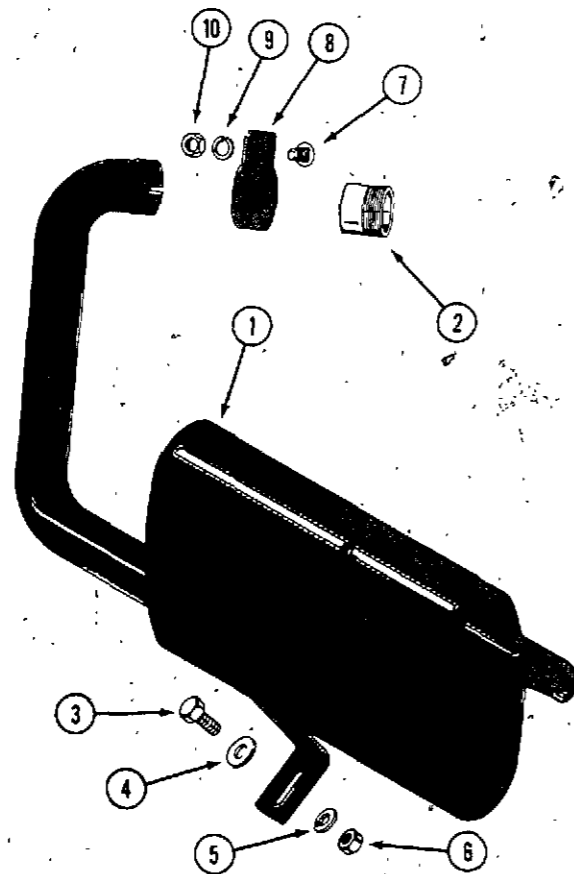

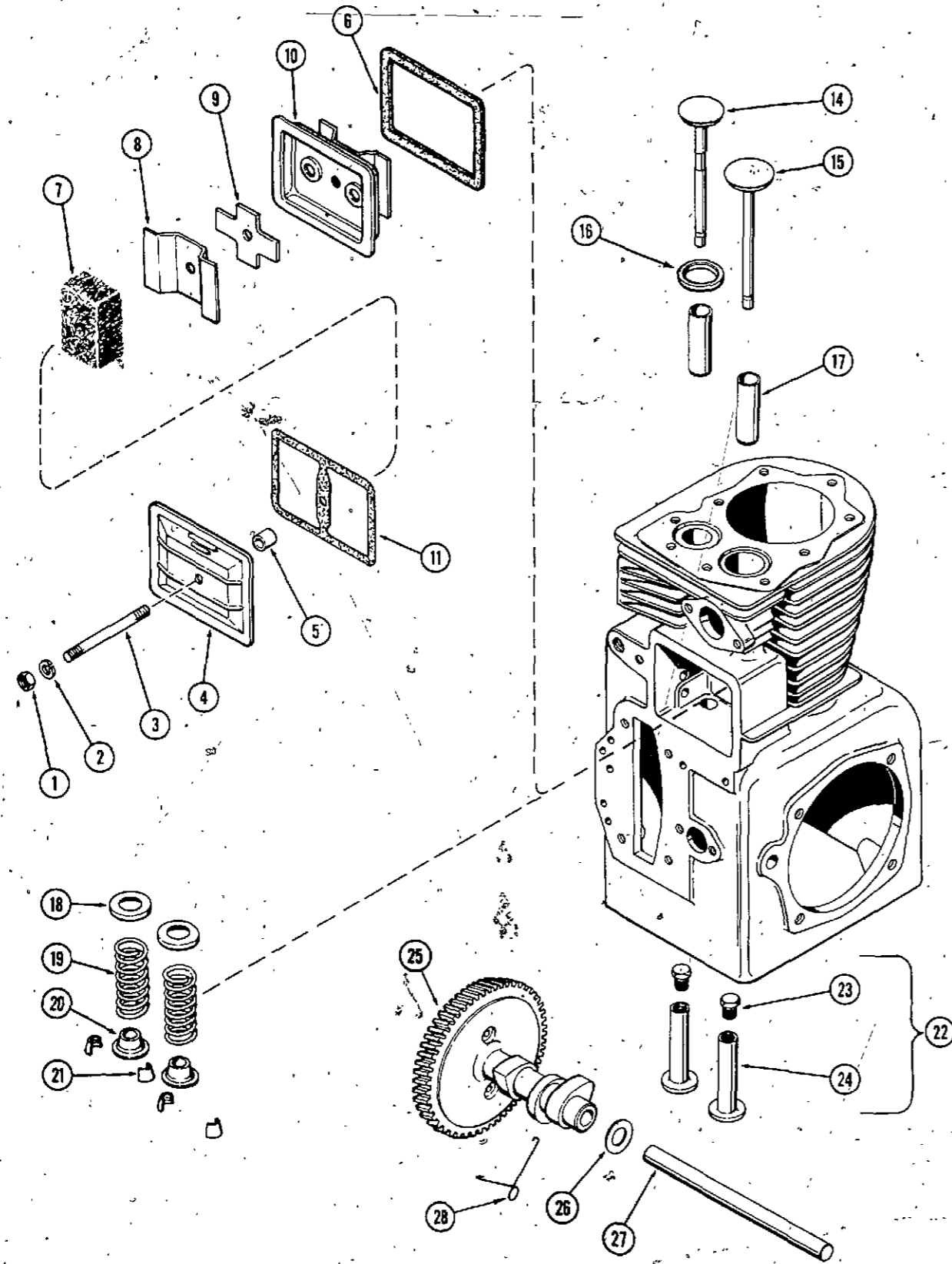

**CRANKCASE BREATHER**

REF.	PART NO.	DESCRIPTION	REQ'D
1	25- 104	NUT - 1/4" NC, hex	1
2	92-	LOCKWASHER - 1/4"	1
3	KO 275220	STUD - valve cover	1
4	KO 275143	COVER - valve	1
5	KO 231032	SEAL - breather	1
6	KO 235048	GASKET - breather plate	1
7	KO 235118	FILTER - breather	1
8	KO 235117	BAFFLE - breather	1
9	KO 235047	REED - breather	1
10	KO 235631	PLATE - breather	1
11	KO 275144	GASKET - valve cover	1

**CAMSHAFT AND VALVES**

14	KO 235826	VALVE - exhaust	1
15	KO 235008	VALVE - intake	1
16	KO 230170	INSERT - exhaust valve seat	1
17	KO 235007-S	GUIDE - valve	2
18	KO 235011	SEAT - valve spring	2
19	KO 235010	SPRING - valve	2
20	KO 230011	RETAINER - valve spring	2
21	KO 240013	LOCK - valve retainer	4
22	KOA235327	LIFTER ASSEMBLY	2
23	NSS	SCREW - tappet adjusting	1
24	NSS	LIFTER - valve	1
25	KOE235646	CAMSHAFT ASSEMBLY	1
26	KO 275066	SPACER - camshaft, .005"	UAR
26	KO 275067	SPACER - camshaft, .010"	UAR
27	KO 235053	PIN - camshaft	1
28	C 22697	SPRING - actuating	1

CRANKSHAFT, PISTON - CONNECTING ROD

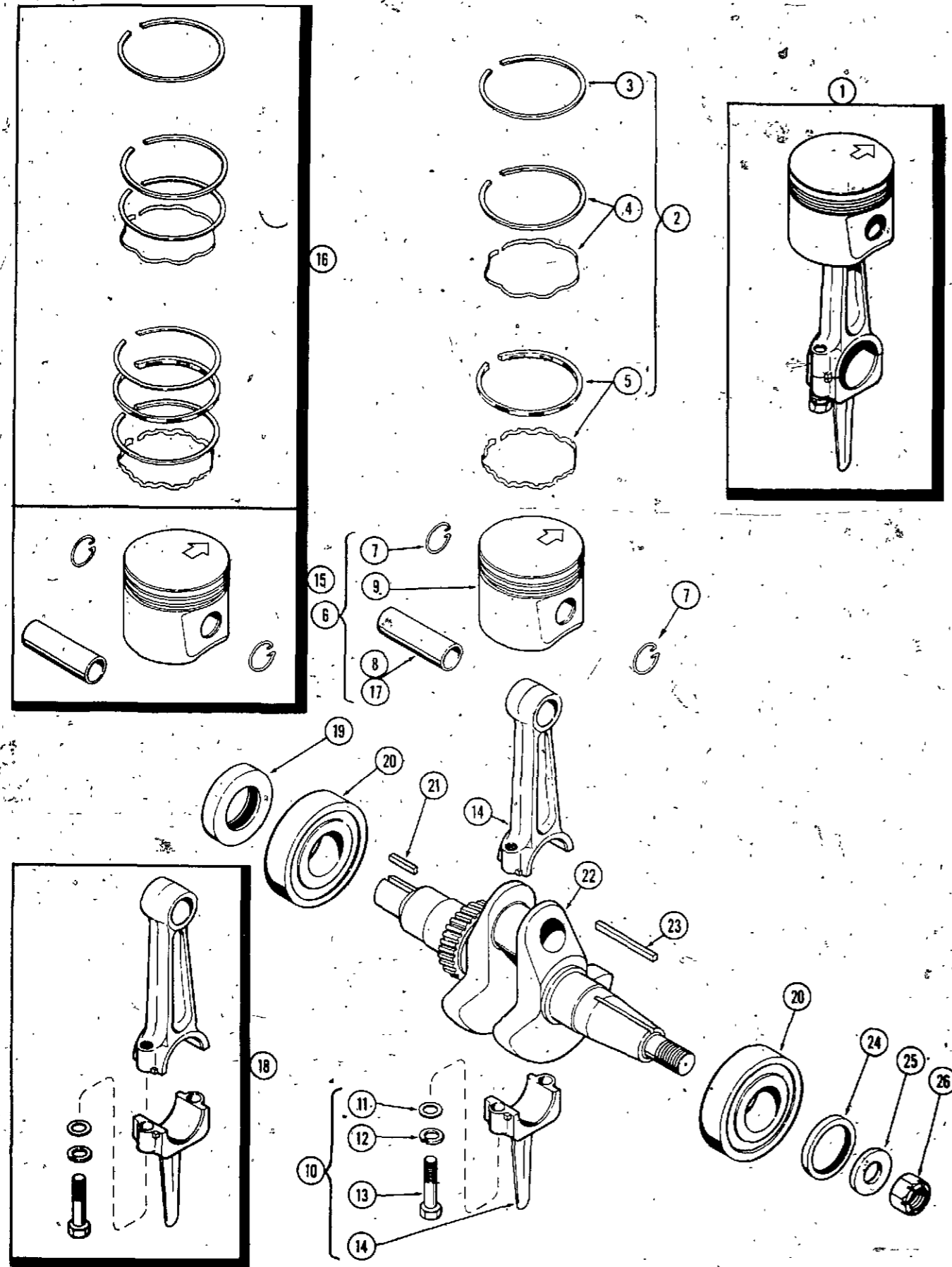

REF.	PART NO.	DESCRIPTION	REQ'D
1	NSS	PISTON AND ROD ASSEMBLY (Std. size)	1
2	KO 235287	RING SET - piston (For oversize, see item 16)	1
3	NSS	RING - top compression	1
4	NSS	RING - 2nd compression (Includes expander)	1
5	NSS	RING - oil (Includes expander)	1
6	KOA 235611	PISTON ASSEMBLY (For oversize, see item 15)	1
7	KO 235004	RETAINER - piston pin	2
8	NSS	PIN - piston	1
9	NSS	PISTON	1
10	KOA 235139	CONNECTING ROD AND ASSEMBLY (For undersize, see item 18)	1
11	KO 235003	WASHER - special	2
12	92- 6	LOCKWASHER	2
13	C 22698	SCREW - cap, connecting rod	2
14	NSS	ROD - connecting	1
15	KOA 235567	PISTON ASSEMBLY - .003 oversize	1
15	KOA 235569	PISTON ASSEMBLY - .010" oversize	1
15	KOA 235571	PISTON ASSEMBLY - .020" oversize	1
15	KOA 235616	PISTON ASSEMBLY - .030" oversize	1
16	KO 235468	RING SET - piston - .010" oversize	1
16	KO 235289	RING SET - piston - .020" oversize	1
16	KO 235290	RING SET - piston - .030" oversize	1
17	NSS	PIN - piston, .005" oversize	1
18	C 18101	CONNECTING ROD ASSEMBLY - .010" undersize	1
19	R 16287	OIL SEAL - crankshaft rear	1
20	40035	BEARING - crankshaft ball	2
21	W 5063-S	KEY - 1/4" Sq. x 3/4" (Pump Coupling)	1
22	KOB 236364	CRANKSHAFT	1
23	A 27001	KEY - flat 3/16" x 3/16" x 1-3/8" (Flywheel)	1
24	C 18097	OIL SEAL - crankshaft front	1
25	195- 545	WASHER - 5/8"	1
26	131- 309	NUT - special Marsden 5/8" NF	1

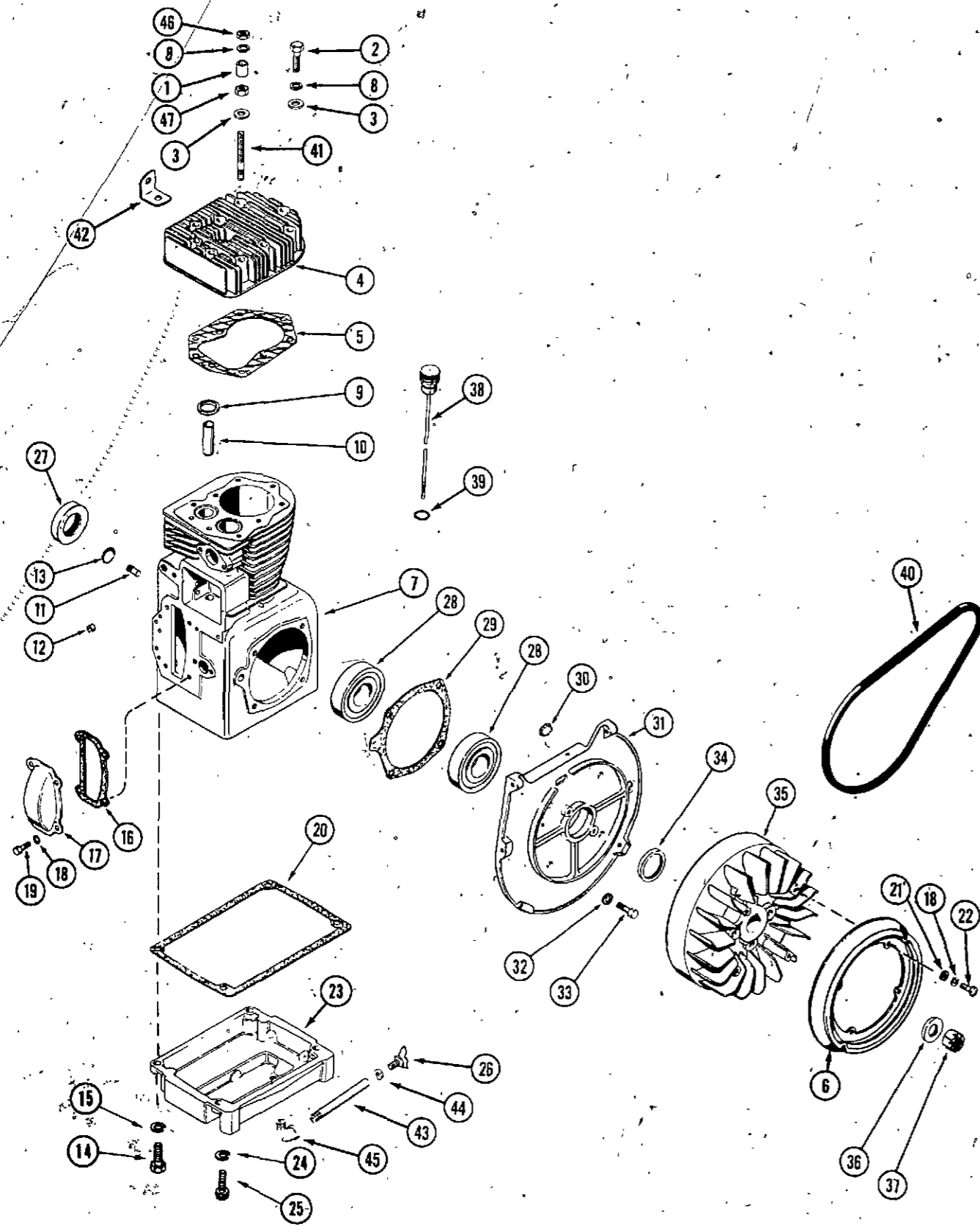

ENGINE BLOCK AND ATTACHING PARTS

REF.	PART NO.	DESCRIPTION	REQ'D
1	C 21814	SPACER - cylinder head	6
2	KO 270158	BOLT - cylinder head 3/8 x 1-1/2" NC hex	3
3	KO 270889	WASHER - cylinder head bolt	9
4	KO 236675	HEAD - cylinder	1
5	KO 237658	GASKET - head	1
6	KO 235207	PULLEY - starter	1
7	A 236303	BLOCK ASSEMBLY - cylinder, (Includes crankshaft, rod assembly, camshaft, valves, bearings and plate)	1
8	192- 21	LOCKWASHER - 3/8"	9
9	KO 230170	INSERT - exhaust valve	1
10	KO 235007-S	GUIDE - valve	2
11	KO 235125-S	SHAFT - stub governor	1
12	KO 234866	BEARING - needle, governor shaft	1
13	41- 18	PLUG - expansion	1
14	113- 206	BOLT - 3/8" x 1-1/4" NC hex plated	4
15	192- 21	LOCKWASHER - 3/8" plated	4
16	KO 235025	GASKET - camshaft cover	1
17	KO 235026	COVER - camshaft gear	1
18	192- 19	LOCKWASHER - 1/4" plated	8
19	113- 6	BOLT - 1/4" x 1/2" NC plated	4
20	KO 235353	GASKET - oil pan	1
21	195- 515	WASHER - 1/4" zinc plated	4
22	175- 436	SCREW - 1/4" x 5/8" NC truss head Phillips, zinc plated	4
23	C 22699	BASE - oil pan	1
24	192- 21	LOCKWASHER - 3/8" plated	4
25	61- 616	BOLT - 3/8" x 1" NC socket head	4
26	C 14399	PLUG - oil drain	1
27	R 16287	OIL SEAL - crankshaft rear	1
28	40035	BEARING - crankshaft ball	2
29	KO 235757	GASKET - shim, bearing plate .010"	1
29	KO 235070	GASKET - shim, .010"	UAR
30	205- 27	PLUG - button, timing hole	1
31	C 22700	PLATE - bearing	1
32	192- 21	LOCKWASHER - 3/8" plated	4
33	113- 207	BOLT - 3/8" x 1" NC plated	4
34	C 18097	OIL SEAL - crankshaft front	1
35	KO 235818	FLYWHEEL	1
36	195- 545	WASHER - special, plated	1
37	131- 309	NUT - special, Marsden	1
38	C 14953	DIPSTICK ASSEMBLY	1
39	A 27365	"O" RING - dipstick	1
40	C 14345	BELT - drive, starter - generator	1
41	KO 237277	STUD - cylinder head	6
42	KO 235748	STRAP - lifting	1
43	C 18814	NIPPLE - oil drain extension	1
44	C 14906	GASKET - plug, oil drain	1
45	221- 1412	ELBOW - street	1
46	129- 143	NUT - 3/8" NC hex, jam	6
47	129- 103	NUT - 3/8" NC hex	6

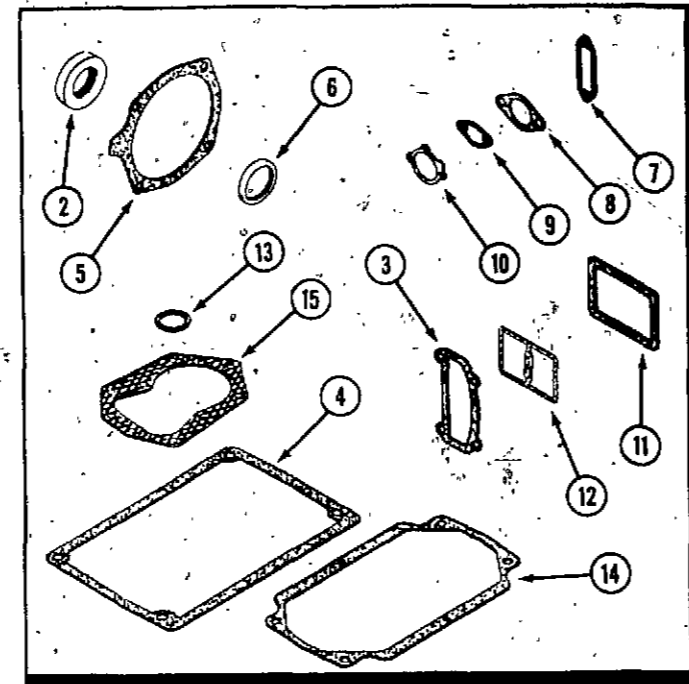

REF.	PART NO.	DESCRIPTION	REQ'D
1	KO 235165	KIT - engine gasket	1
2	R 16287	SEAL - crankshaft, rear	1
3	KO 235025	GASKET - camshaft cover	1
4	KO 235353	GASKET - oil pan	1
5	KO 235757	GASKET - shim, bearing plate (.010")	6
5	KO 235070	GASKET - shim (.010")	UAR
6	C 18097	SEAL - crankshaft, front	1
7	KO 220174	GASKET - breaker cover	1
8	A 72100	GASKET - carburetor flange	1
9	A 72108	GASKET - fuel pump flange	1
10	KO 275341	GASKET - carburetor air horn	1
11	KO 235048	GASKET - breather plate	1
12	KO 275144	GASKET - valve cover	1
13	B 53393	GASKET - fuel strainer bowl (not used)	1
14	KO 235057	GASKET - pan (not used)	1
15	KO 236705	GASKET - cylinder head	1

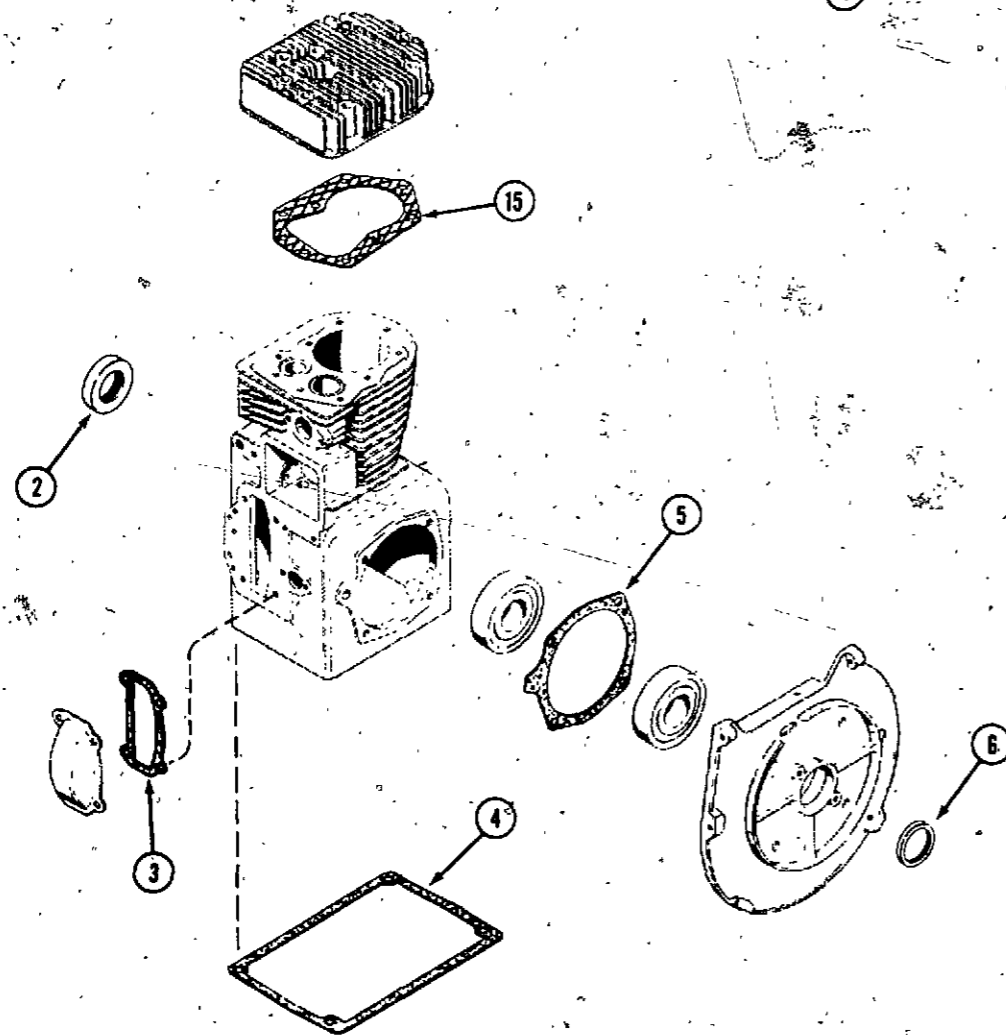

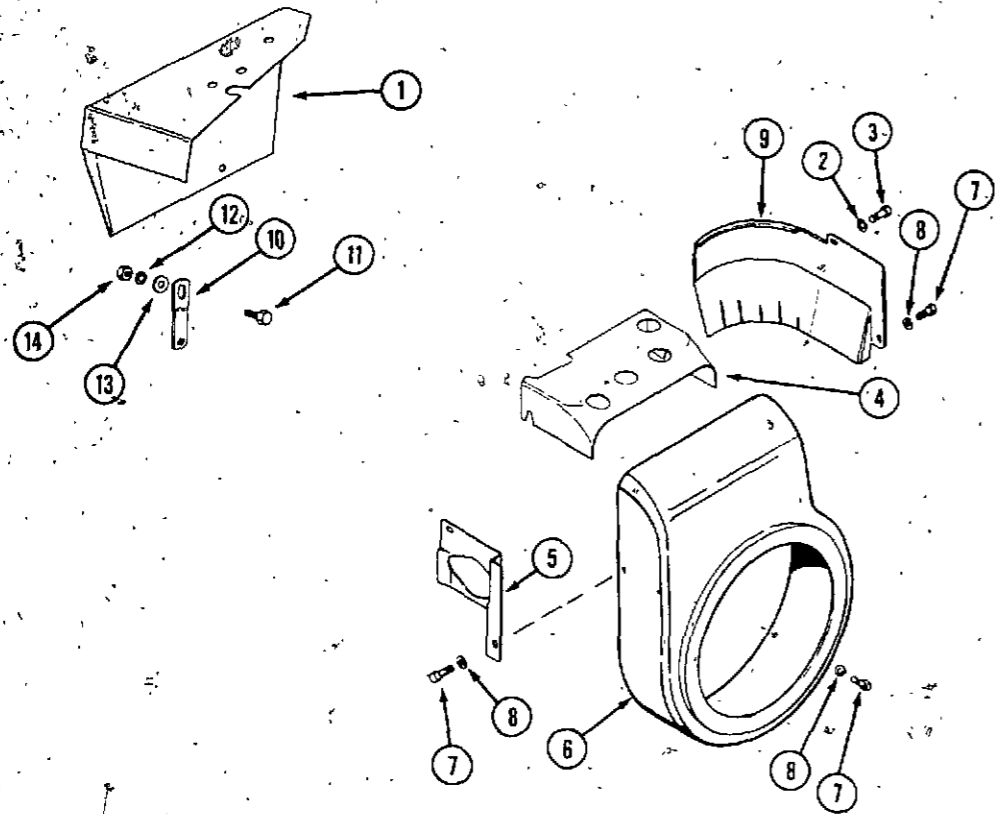

**BAFFLES AND SHROUDS**

REF.	PART NO.	DESCRIPTION	REQ'D
1	C 18989	DEFLECTOR - engine air	1
2	192- 19	LOCKWASHER - 1/4" zinc plated	2
3	113- 6	BOLT - 1/4" x 1/2" NC hex, zinc plated	2
4	KO 237520	BAFFLE - cylinder head	1
5	KO 235652	BAFFLE - carburetor side air	1
6	KO 235901	HOUSING - blower	1
7	113- 2	BOLT - 1/4" x 3/4" NC hex, zinc plated	4
8	192- 19	LOCKWASHER - 1/4" zinc plated	4
9	KO 235054	BAFFLE - cylinder	1
10	C 19021	SUPPORT - engine air deflector	1
11	113- 118	BOLT - 5/16" x 5/8" NC hex	1
12	192- 20	LOCKWASHER - 5/16"	1
13	195- 521	WASHER - 5/16" plain	1
14	129- 102	NUT - 5/16" NC hex	1

**FUEL SYSTEM**

1	A 72073	CARBURETOR ASSEMBLY -	1
2	A 72100	GASKET - carburetor flange	1
3	C 10678	ELBOW - fuel pump and carburetor	3
4	214- 103	CLAMP - hose	4
5	C 15007	HOSE - carburetor 5-1/5"	1
6	192- 20	LOCKWASHER - 5/16"	2
7	113- 103	BOLT - 5/16" x 1" NC hex	2
8	KQA 235845	PUMP - fuel, 10 h.p. (Repairs page 17)	1
9	71 410	SCREW - 1/4" x 5/8" NC fillister head	2
10	193- 60	LOCKWASHER - 1/4"	2
11	KO 275341	GASKET - air horn	1
13	A 72108	GASKET - fuel pump mounting	1
14	C 10657	ELBOW ASSEMBLY - fuel tank	1
15	C 14157	CLIP - fuel line	2
16	C 21984	HOSE - fuel line - 38-1/2"	1
17	C 16363	TANK - fuel	1
18	C 11529	CAP - fuel tank (Includes insert)	1
19	C 11545	INSERT - fuel cap	1
20	C 16796	STRAP - fuel tank mounting	2
21	173- 215	SCREW - 1/4" x 1-1/2" NC round head, machine, zinc plated	2
22	129- 504	NUT - square 1/4" NC	2
23	C 14690	CUSHION - fuel tank	2

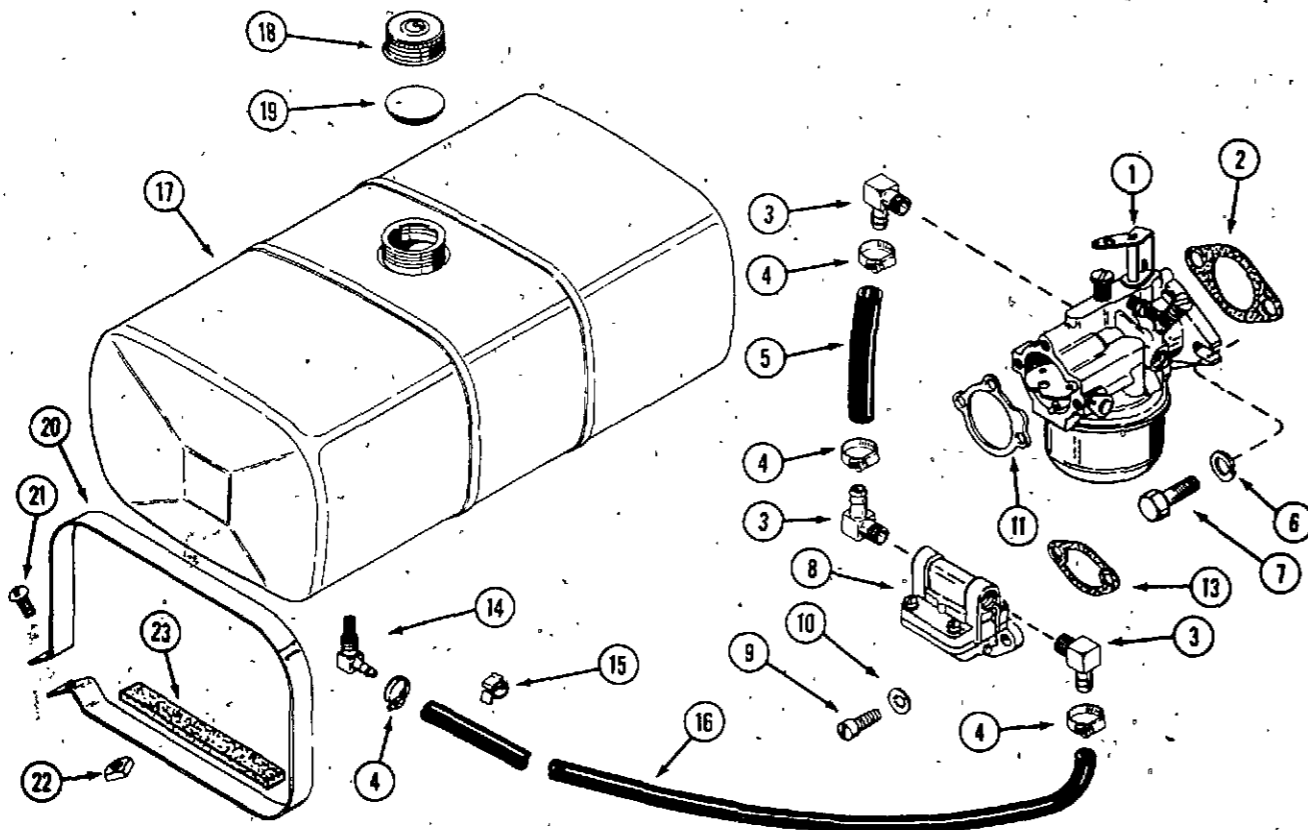



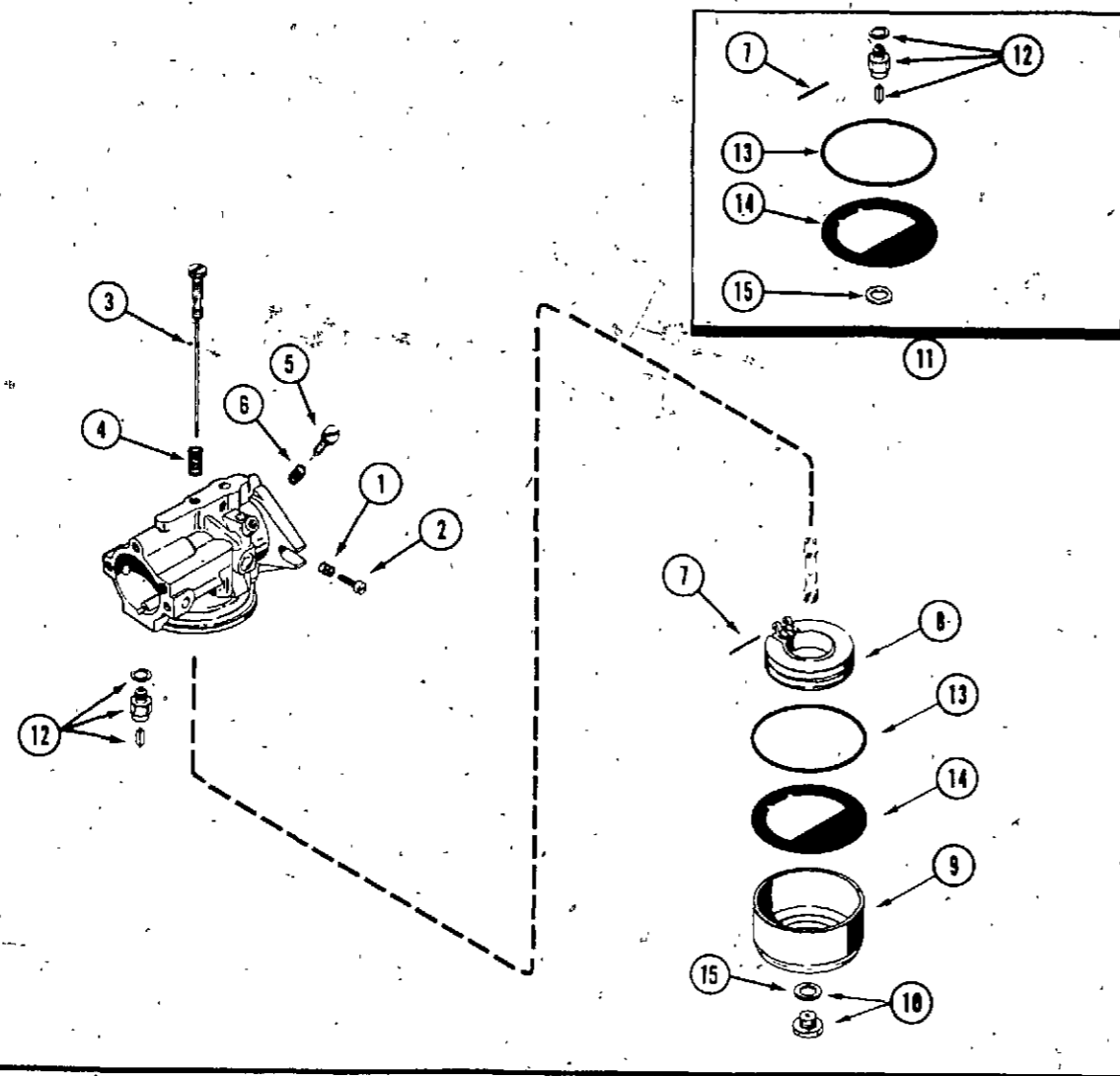

**A72073 CARBURETOR**

REF.	PART NO.	DESCRIPTION	REQ'D
	A 72073	CARBURETOR ASSEMBLY	1
1	KO 200380	SPRING - tension, idle adjust	1
2	A 72092	SCREW - idle adjust	1
3	A 72077	NEEDLE - main fuel adjust	1
4	KO 200383	SPRING - main fuel adjust	1
5	A 72099	NEEDLE - idle adjust	1
6	KO 200380	SPRING - idle fuel adjust	1
7	A 72079	PIN - float	1
8	A 72078	FLOAT - carburetor	1
9	A 72080	BOWL - carburetor	1
10	A 72084	SCREW AND GASKET ASSEMBLY - carburetor bowl	1
11	A 72103	KIT - carburetor repair	1
12	NSS	INLET NEEDLE AND SEAT ASSEMBLY	1
13	NSS	GASKET - bowl ring	1
14	NSS	GASKET - bowl baffle	1
15	A 72083	GASKET - bowl screw	1

**FUEL PUMP**

1	KO 230675	KIT - fuel pump for KOA235845 pump	1
	NSS	SPRING - fuel pump valve	2
	NSS	VALVE	2
	NSS	GASKET - valve	1
	NSS	DIAPHRAGM ASSEMBLY	1
2	A 72108	GASKET - fuel pump mounting	1

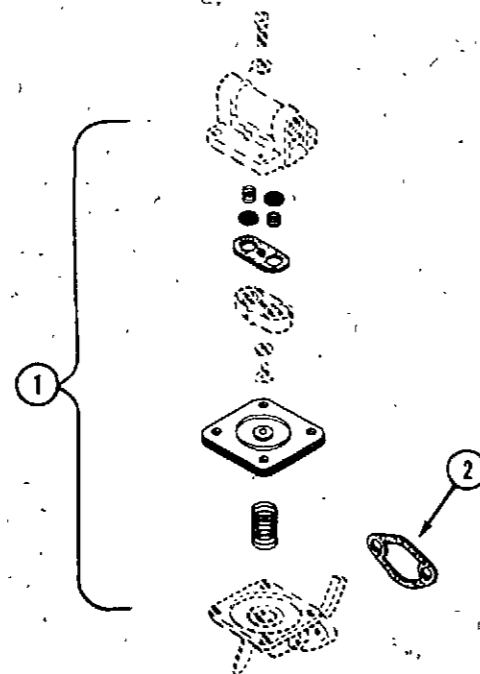

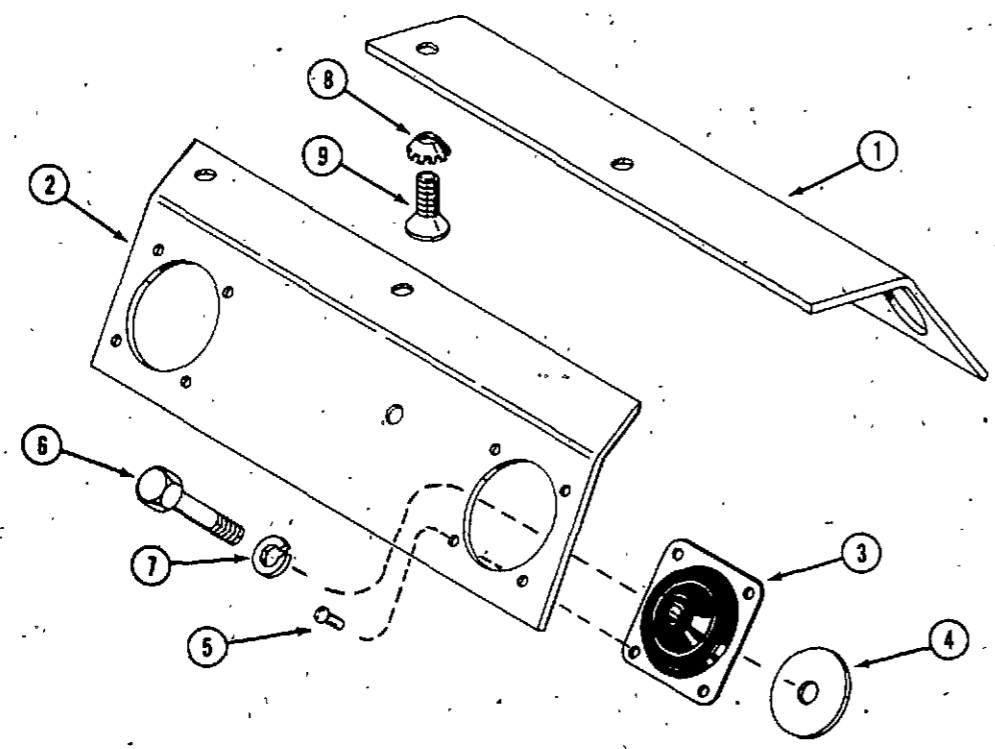
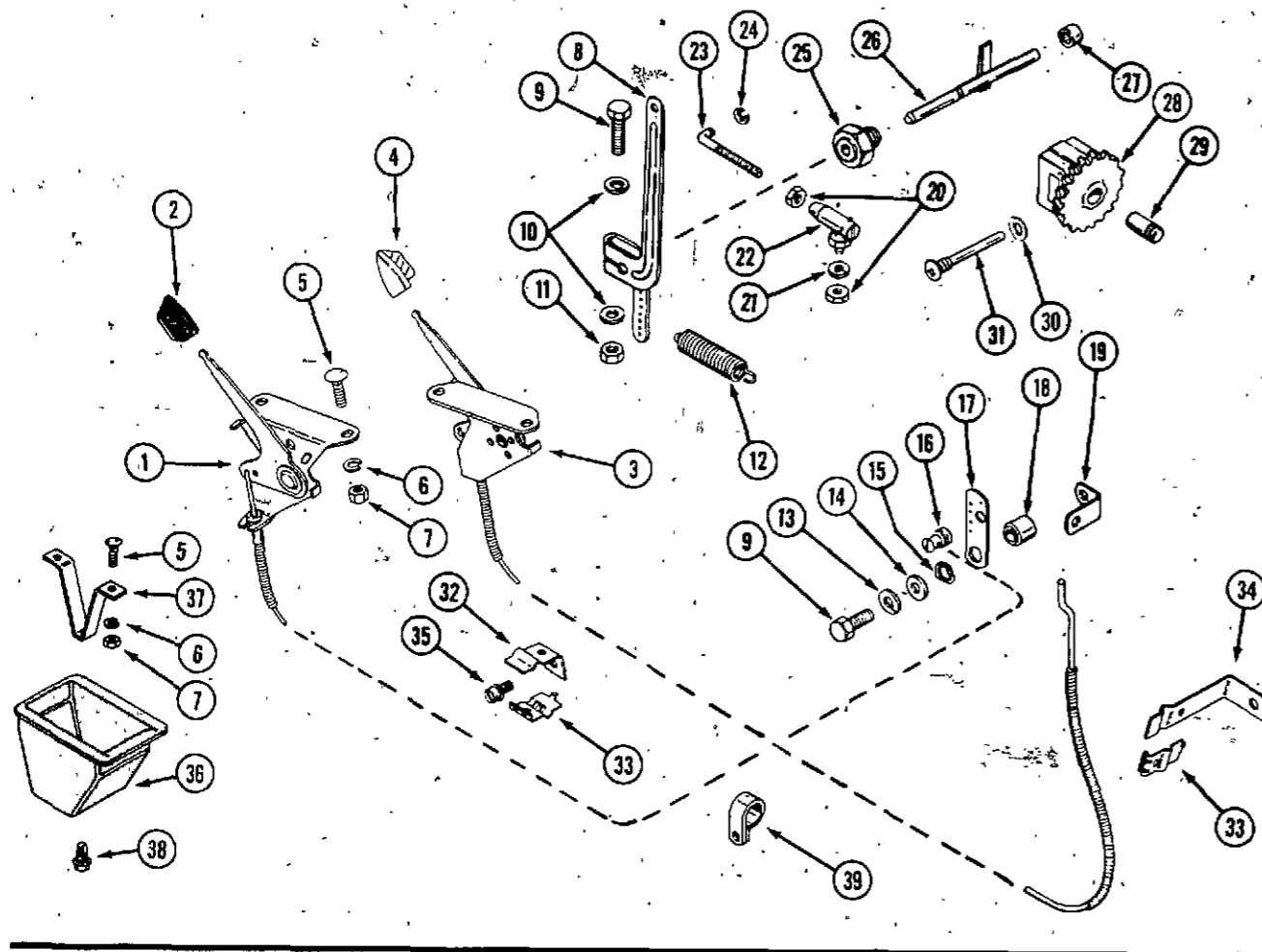

**CHOKE, THROTTLE AND GOVERNOR**

REF.	PART NO.	DESCRIPTION	REQ'D
1	C 16449	CONTROL - throttle	1
2	C 12224	HANDLE - throttle control, black	1
3	C 16448	CONTROL - choke	1
4	C 14506	HANDLE - choke control, white	1
5	111- 3	BOLT - 10-24 x 5/8" round head, square neck	4
6	192- 18	LOCKWASHER - #10 Std. plated	4
7	129- 17	NUT - #10-24 plated	4
8	KO 235494	LEVER - governor	1
9	15- 420	BOLT - 1/4" x 1-1/4" NC hex	2
10	195- 515	WASHER - 1/4" plated	2
11	25- 104	NUT - 1/4" hex	1
12	KO 235496	SPRING - governor	1
13	192- 19	LOCKWASHER - 1/4" plated	1
14	C 18098	WASHER - thrust	1
15	KO 275690	WASHER - wavy	1
16	KO 231052	CLAMP - swivel, wire	1
17	KO 235086	LEVER - speed control	1
18	KO 235085	SPACER - speed control bracket	1
19	KO 235084	BRACKET - high speed stop	1
20	129- 37	NUT - #10-32 hex	2
21	192- 18	LOCKWASHER - 3/16" plated	1
22	A 10326	JOINT - ball	1
23	KO 235277	ROD - throttle	1
24	KO 235278	RING - retaining, throttle rod	1
25	KO 235476	BUSHING - governor cross shaft	1
26	KO 237455	SHAFT ASSEMBLY - governor cross	1
27	C 18103	BEARING - needle, governor shaft	1
28	KOA 237031	GEAR ASSEMBLY - governor	1
29	KO 235125-S	SHAFT - governor stub	1
30	C 18099	WASHER - governor stop pin	1
31	KO 231355	PIN - governor stop	1
32	KO 236835	BRACKET - throttle cable	1
33	KO 235603	CLIP - bracket	2
34	KO 235680	BRACKET - choke cable	1
35	169- 95	SCREW - #10 x 3/8" NC fillister head	1
36	C 20193	ENCLOSURE - choke and throttle cable	1
37	C 20194	BRACKET - enclosure mtg.	1
38	187- 1036	SCREW - 1/4" x 1/2" hex self tapping	1
39	C 21679	CLAMP - choke & throttle cable	1

**ENGINE MOUNTING PLATE**

1	C 17717	PLATE - engine mount, L.H.	1
2	C 17718	PLATE - engine mount, R.H.	1
3	C 18793	MOUNT - engine	4
4	D 22988	WASHER - snubbing	4
5	151- 210	RIVET - semi tubular	16
6	113- 219	BOLT - 3/8" x 2" NC hex	4
7	192- 21	LOCKWASHER - 3/8"	4
8	193- 56	LOCKWASHER - 3/8" countersunk external tooth	4
9	164- 50	BOLT - flat head, hex. socket	4

PTO CLUTCH AND LINKAGE

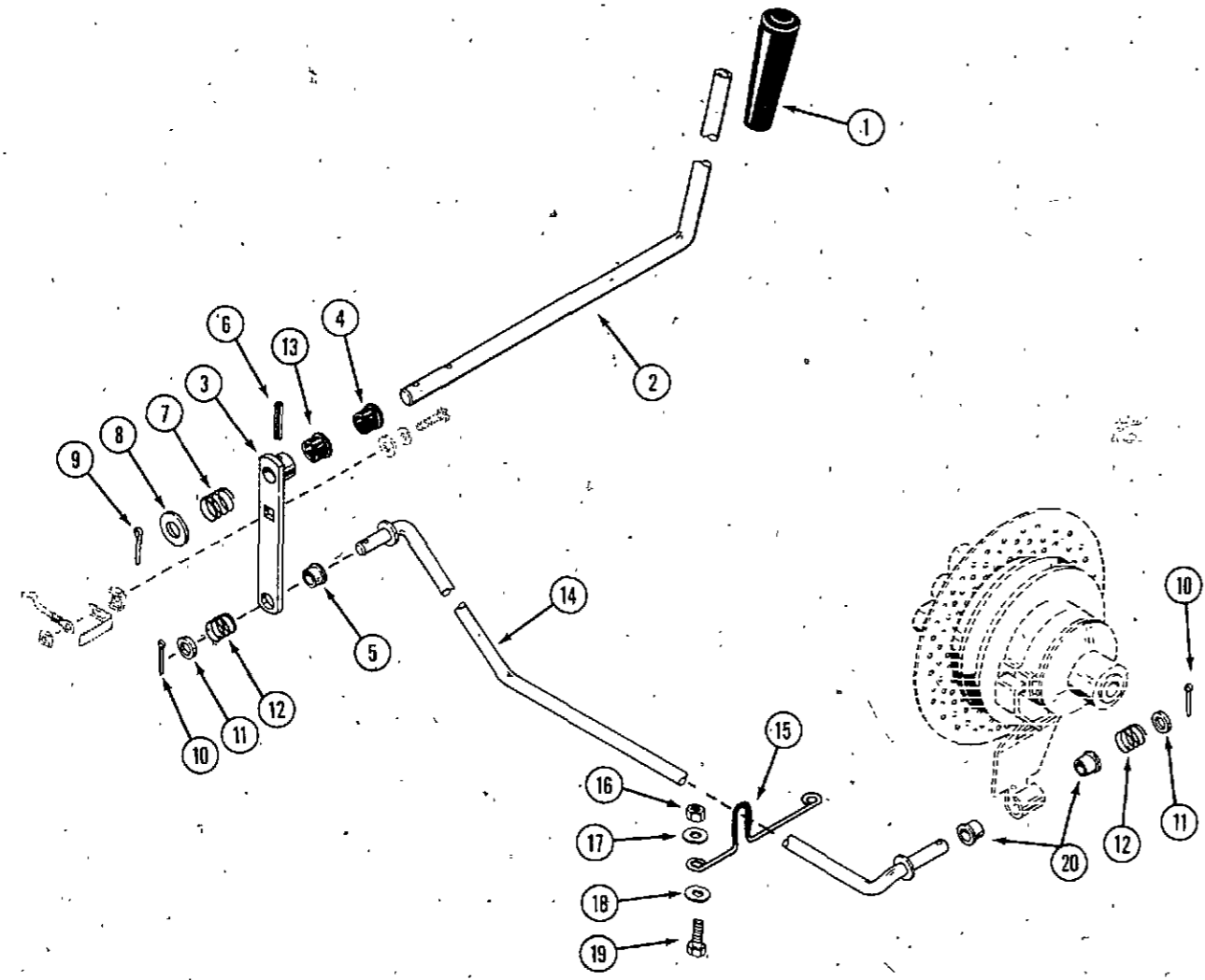

REF.	PART NO.	DESCRIPTION	REQ'D
1	A 37247	KNOB - lever, PTO	1
2	C 20037	LEVER - PTO engaging	1
3	C 20035	ARM ASSEMBLY - PTO	1
4	353- 462	BUSHING - lever, dash tower	1
5	C 20093	BUSHING - fliplock	1
6	138- '96	PIN - roll 3/16 x 1"	1
7	C 20036	SPRING - lever, PTO	1
8	A 39519	WASHER - nylon	1
9	132- 91	PIN - cotter 3/16 x 1"	1
10	132- 48	PIN - cotter 1/8 x 1"	2
11	C 14906	WASHER - nylon 3/8"	2
12	C 19867	SPRING - clutch rod	2
13	353- 442	BUSHING - heyco, clutch rod	1
14	C 20107	ROD - clutch	1
15	C 19767	GUIDE - clutch rod	1
16	131- 178	NUT - lock 3/8" n.c. hex	2
17	195- 104	WASHER - 3/8"	2
18	195- 126	WASHER - spacer (used on models without hyd. lift)	2
19	113- 207	BOLT - 3/8 x 1" n.c. hex	2
20	C 20053	BUSHING - nylon	2

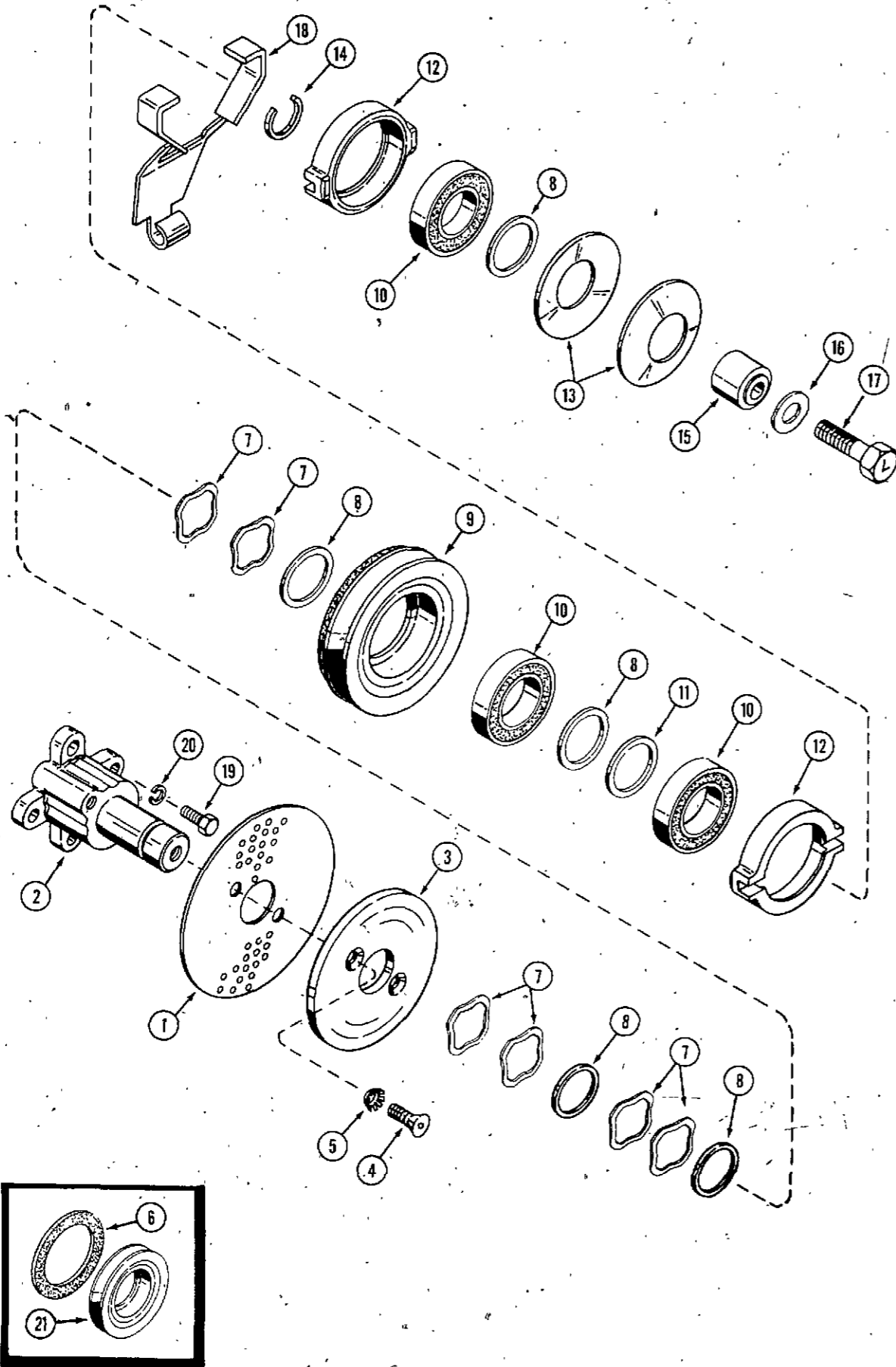

CLUTCH ASSEMBLY (PTO)

REF.	PART NO.	DESCRIPTION	REQ'D
	C 19802	CLUTCH AND SCREEN ASSEMBLY .....	1
1	C 15721	SCREEN - grass .....	1
2	C 18907	HUB - clutch .....	1
3	C 15718	PLATE - clutch .....	1
4	164- 40	BOLT - 5/16" x 3/4" NC flat head socket .....	2
5	193- 76	LOCKWASHER - 5/16" countersunk external tooth. ....	2
6	C 14291	DISC - friction .....	1
7	C 15515	WASHER - spring .....	6
8	C 15557	WASHER - spacer .050" .....	UAR
9	C 22671	PULLEY AND DISC ASSEMBLY - clutch .....	1
10	C 23245	BEARING - cam and pulley .....	3
11	C 21596	WASHER - spacer .005" .....	UAR
11	C 15556	WASHER - spacer .010" .....	UAR
12	NSS	CAM - clutch (service with (2) C23033 cams and (1) C23391 arm) .....	2
13	C 16786	SPRING - clutch load .....	2
14	F 59014	RING - retaining .....	1
15	C 18908	SPACER - hub .....	1
16	O 2815-N	WASHER - fan 17/32" .....	1
17	C 18940	BOLT - 1/2" x 1-3/4" NC hex L.H. threads .....	1
18	C 23391	ARM - engaging .....	1
19	113- 207	BOLT - 3/8" x 1" NC hex ZP .....	4
20	192- 21	LOCKWASHER - 3/8" .....	4
21	NSS	PULLEY - clutch (Order item 9) .....	1
	C 19472	KIT - clutch stub shaft (includes items 2, 8, 11, 14, 15, 16, 17 and 19) .....	1

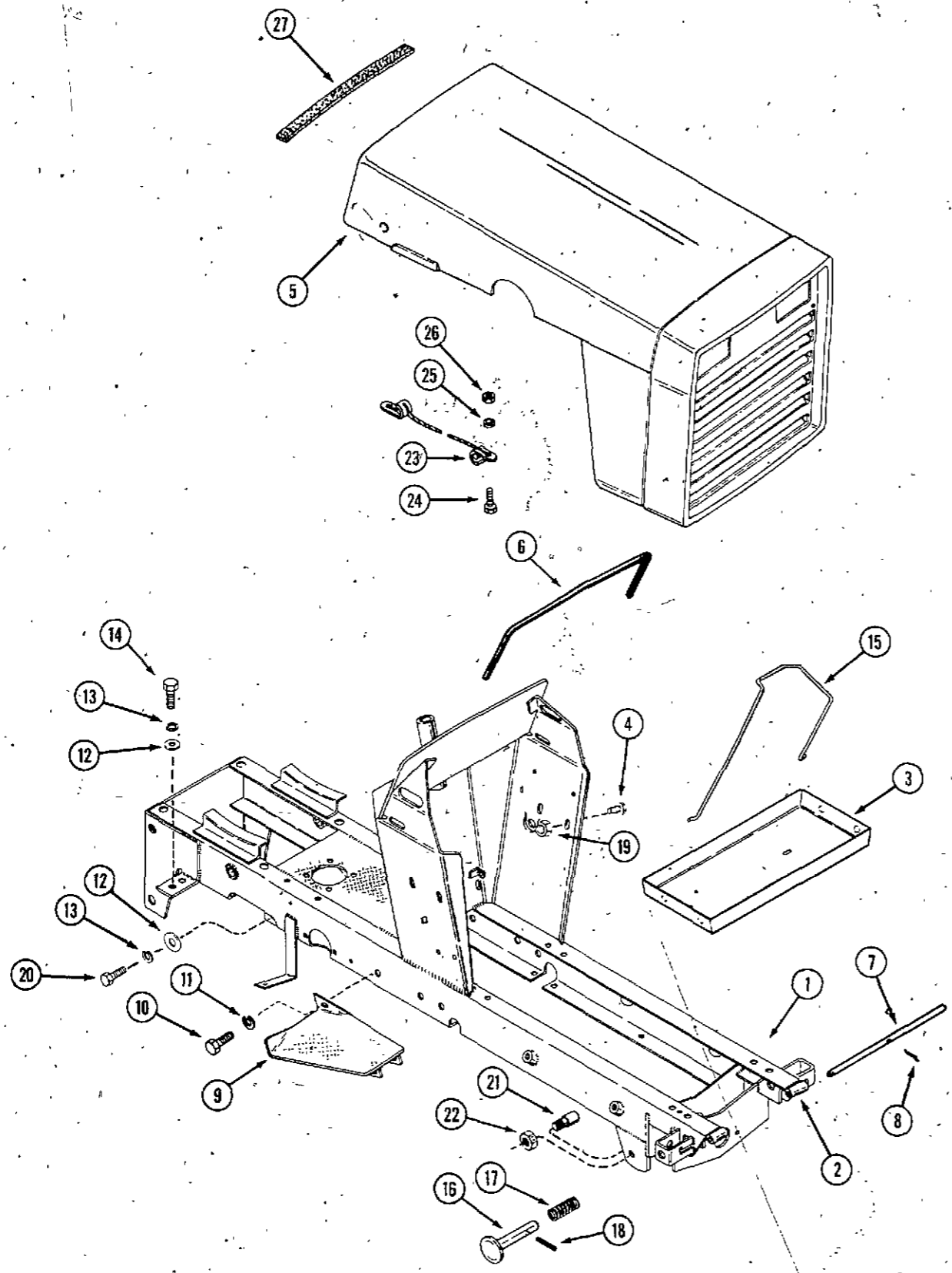

HOOD, FRAME AND GRILLE

REF.	PART NO.	DESCRIPTION	REQ'D
1	C 21955	FRAME - main (S/N 9686461 and after) requires C 18389 ammeter	1
1	C 18940	FRAME - main (used prior to S/N 9686461)	1
2	C 22023	SPACER - head hinge mtg.	2
3	C 16170	TRAY - battery	1
4	121- 106	SCREW - 5/16" x 1/2" whizlock	4
5	C 20056	HOOD AND GRILLE ASSEMBLY (late production)	1
5	C 16364	HOOD AND GRILLE ASSEMBLY (early production, use cat. #1258)	1
6	C 18153	CHANNEL - instrument panel liner	1
7	C 16362	ROD - hood hinge	1
8	132- 46	PIN - cotter 1/8" x 3/4"	1
9	C 18890	PAD - foot L.H.	1
9	C 18150	PAD - foot R.H.	1
10	13- 514	BOLT - 5/16" x 7/8" NC hex	2
11	192- 20	LOCKWASHER - 5/16"	2
12	195- 104	WASHER - 3/8" flat	7
13	192- 21	LOCKWASHER - 3/8"	7
14	113- 206	BOLT - 3/8" x 3/4" NC hex	4
15	C 16239	STRAP - battery hold down	1
16	C 16373	PIN - latch	2
17	C 16374	SPRING - latch	2
18	138- 319	PIN - roll 3/16" x 1-1/4"	2
19	129- 102	NUT - 5/16" NC hex	4
20	113- 207	BOLT - 3/8" x 1" NC hex	3
21	C 18733	PIN - attachment	2
22	131- 1318	NUT - lock 1/2" - #20 NF jam	2
23	C 19283	LANYARD - hood	1
24	113- 3	BOLT - 1/4" x 3/4" NC hex	2
25	192- 19	LOCKWASHER - 1/4"	2
26	129- 101	NUT - 1/4" - #20 hex	2
27	C 20082	LINER - hood	1

SEAT, FENDERS AND TOOL TRAY

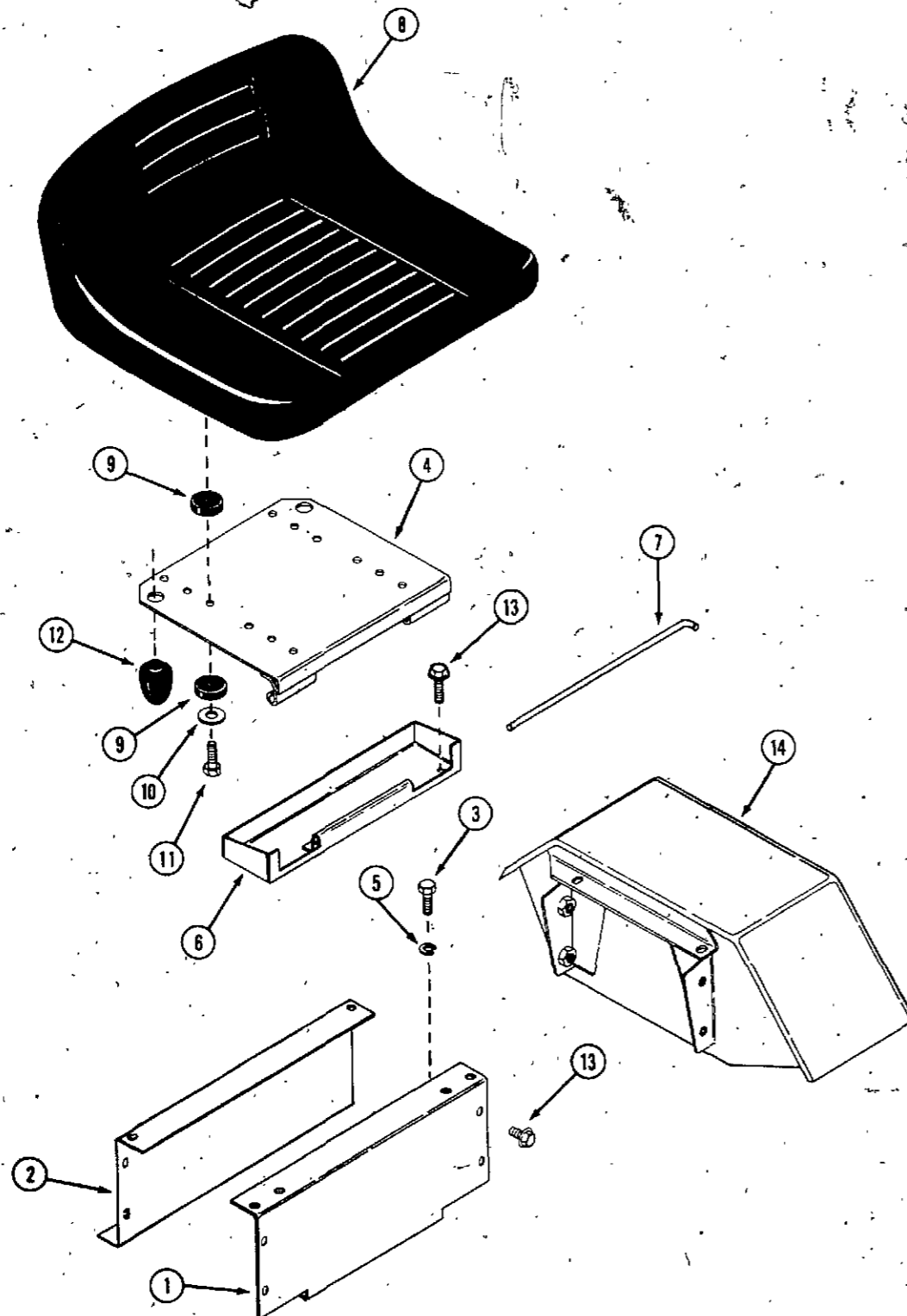

REF.	PART NO.	DESCRIPTION	REQ'D
1	C 18996	SUPPORT - seat, front	1
2	C 16404	SUPPORT - seat, rear	1
3	115- 424	BOLT - 1/2 x 1" NC hex	4
4	C 17152	HINGE ASSEMBLY - seat	1
5	192- 23	LOCKWASHER - 1/2"	4
6	C 19417	TRAY - tool	1
7	C 16429	PIN - seat hinge	1
8	C 16129	SEAT - operators	1
9	C 15410	CUSHION - rubber	8
10	195- 2021	WASHER - 5/16" x 1-1/4" OD, zinc plated	4
11	113- 122	BOLT - 5/16 x 1-1/2"	4
12	C 14534	BUMPER - seat	2
13	121- 106	BOLT - 5/16 x 1/2" flange whizlock	10
14	C 16446	FENDER - L.H.	1
14	C 16447	FENDER - R.H.	1

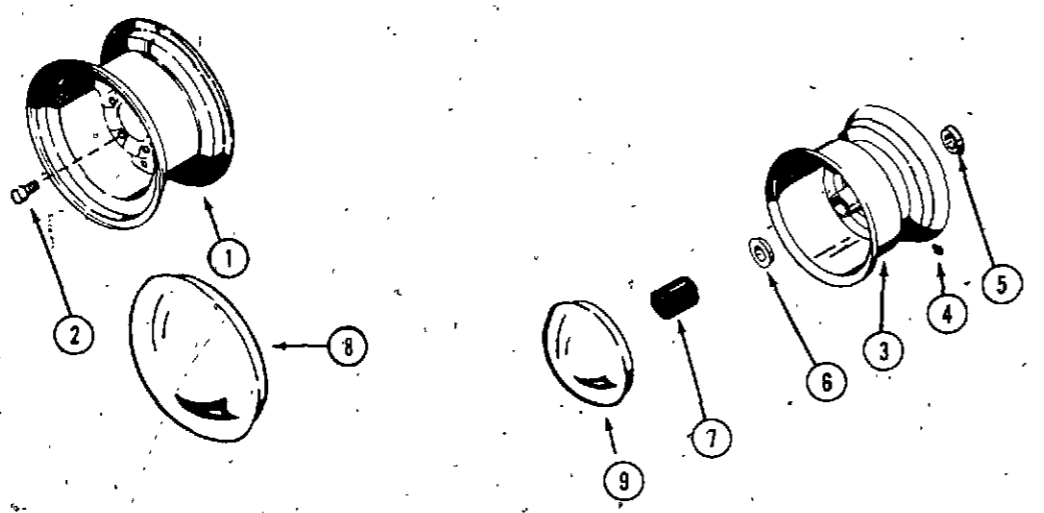
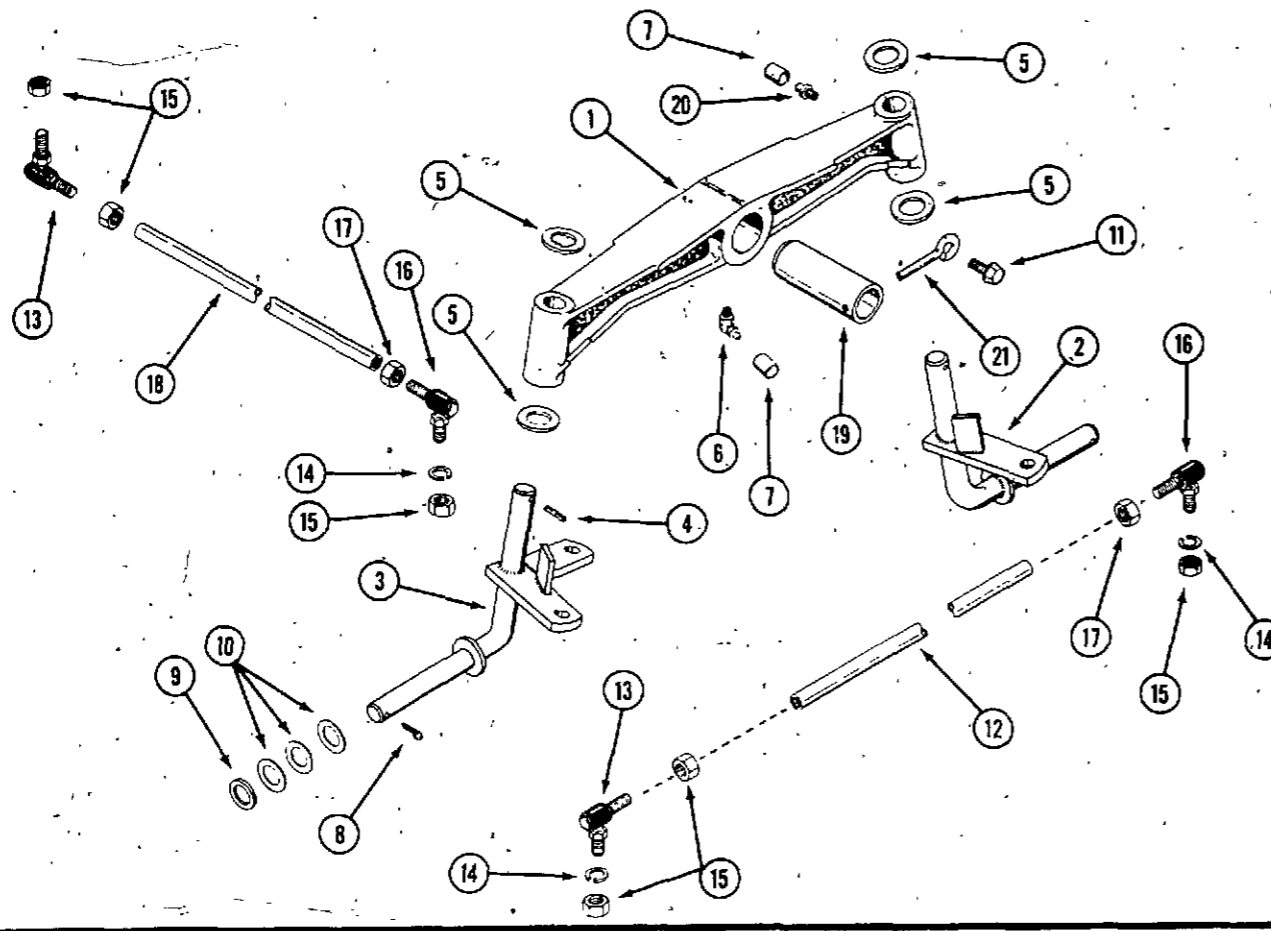

**FRONT AXLE**

REF.	PART NO.	DESCRIPTION	REQ'D
1	C 18812	AXLE - front	1
2	C 18777	SPINDLE - left hand	1
3	C 18779	SPINDLE - right hand	1
4	138- 99	PIN - roll	1
5	C 11906	WASHER - thrust	2
6	219- 404	FITTING - lube	4
7	C 13106	COVER - lube fitting	1
8	132- 311	PIN - cotter 5/32 x 1-1/4"	3
9	C 12975	WASHER - wheel spindle	2
10	A 30881	WASHER - wheel spacer	2
11	187- 1046	BOLT - 3/8" NC idented hex head	6
12	C 21530	TIE ROD	1
13	C 21526	BALL JOINT - 1/2" R.H. thread	1
14	192- 23	LOCKWASHER - 1/2" zinc plated	2
15	129- 125	NUT - 1/2" NF hex R.H. thread	3
16	C 21527	BALL JOINT - 1/2" L.H. thread	6
17	129- 325	NUT - 1/2" NF hex L.H. thread	2
18	C 21528	ROD - drag link	2
19	C 22568	TUBE - axle pivot	1
20	219- 17	FITTING - lube	1
21	C 22278	PIN - retaining	2

**FRONT AND REAR WHEELS**

1	C 10263	WHEEL - rear, 5 bolt	2
2	C 10314	BOLT - rear wheel	10
3	C 12081	WHEEL - front	2
4	219- 403	FITTING - lube	2
5	C 12110	BEARING - wheel, inner	2
6	C 12111	BEARING - wheel, outer	2
7	C 12370	CAP - plastic, front	2
8	A 70185	CAP - hub, rear (optional)	2
9	A 70062	CAP - hub front wheel (optional)	2

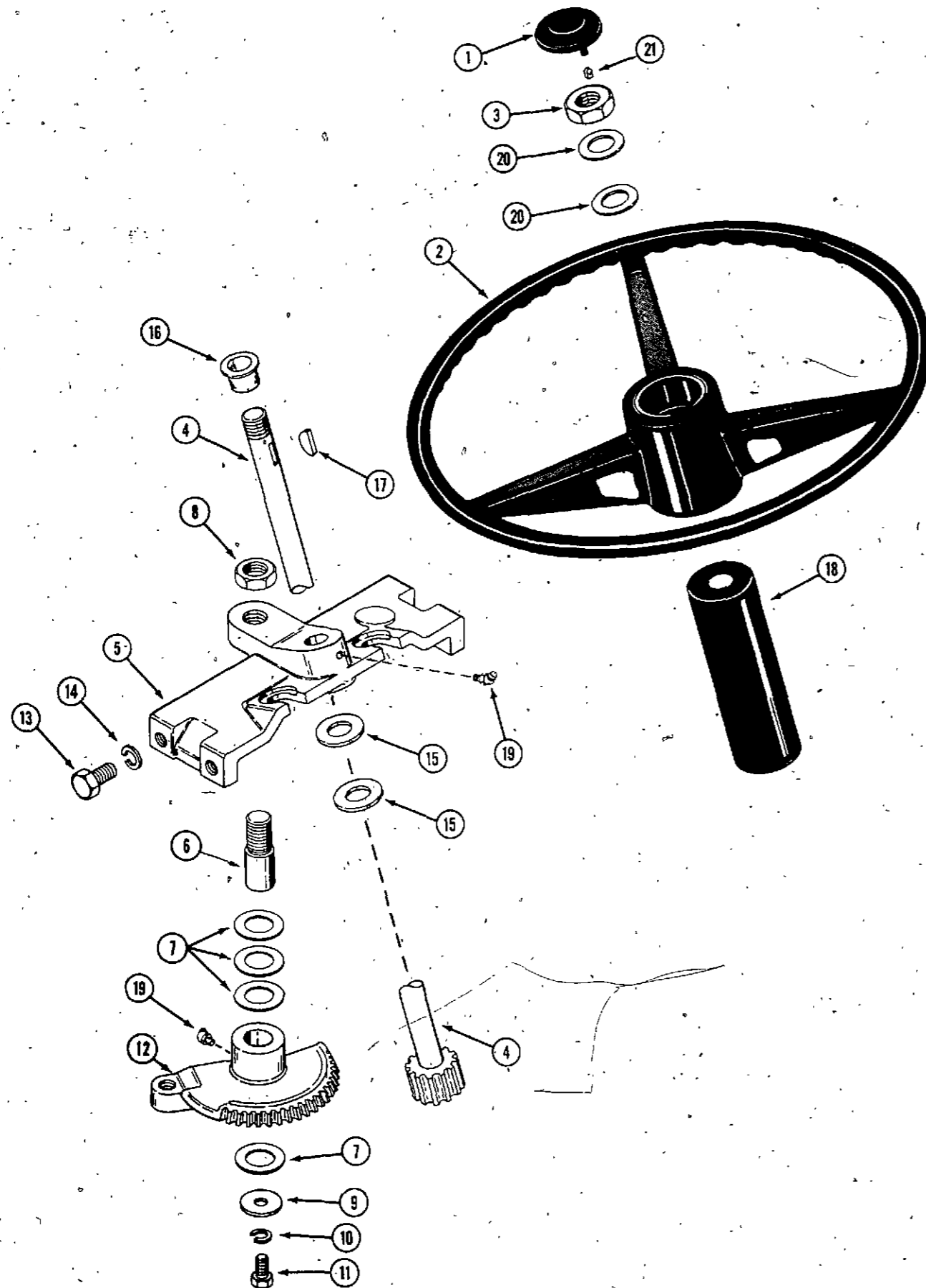

STEERING GEAR

REF.	PART NO.	DESCRIPTION	REQ'D
1	C 18016	CAP - steering wheel	1
2	C 18014	WHEEL - steering	1
3	131- 1113	NUT - lock 5/8"	1
4	C 16200	SHAFT - steering	1
5	C 18992	SUPPORT - steering gear	1
6	C 14200	PIN - pivot	1
7	C 14201	WASHER - shim	4
8	131- 1112	NUT - jam 3/4"	1
9	195- 2021	WASHER	1
10	192- 20	LOCKWASHER - 5/16" zinc plated	1
11	113- 113	BOLT - 5/16" x 7/8" NC hex	1
12	C 18711	GEAR - steering	1
13	113- 206	BOLT - 3/8" x 3/4" NC hex	4
14	192- 21	LOCKWASHER - 3/8"	4
15	195- 2069	WASHER - 5/8" zinc plated	2
16	C 15096	BUSHING - flanged nylon	1
17	126- 16	KEY - Woodruff 3/16" x 3/4"	1
18	C 16692	TUBE - steering	1
19	219- 404	FITTING - lube 45°	2
20	C 12975	WASHER - 5/8"	2
21	C 18017	CLIP - tinnerman (use with C18014 steering wheel)	2



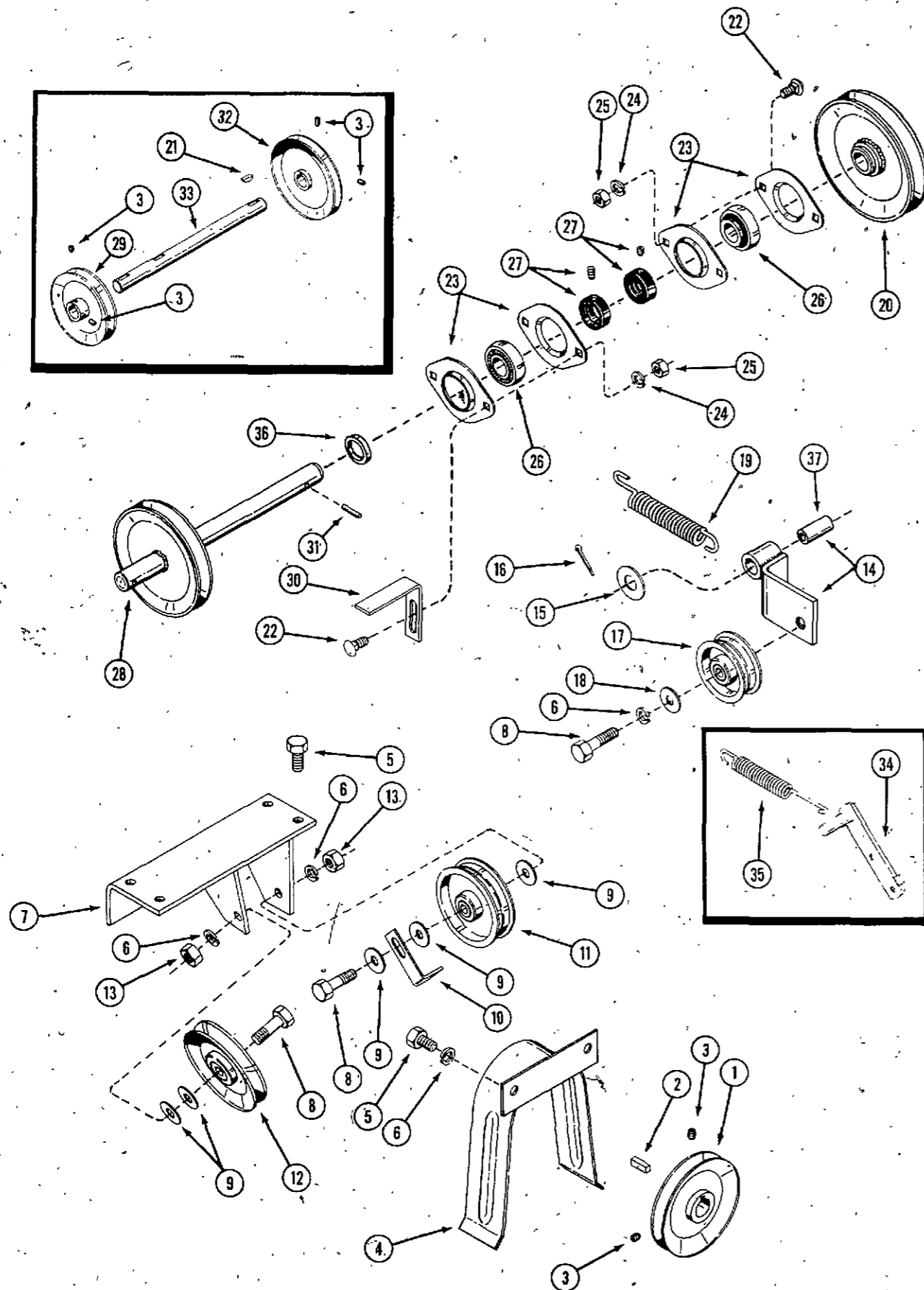

**DRIVE PULLEYS, IDLERS AND JACKSHAFT  
(INCLUDES FIELD MODIFICATION)**

REF.	PART NO.	DESCRIPTION	REQ'D
1	C 23522	PULLEY - engine	1
2	W 5063-S	KEY - square 1/2" x 3/4"	1
3	178- 858	SETSCREW - 5/16" x 3/8"	2
4	C 19869	GUARD - belt	1
5	113- 206	BOLT - 3/8" x 3/4" NC hex	6
6	192- 21	LOCKWASHER - 3/8"	6
7	C 18974	BRACKET - drive idler mounting	1
8	113- 208	BOLT - 3/8" x 1-1/4" NC hex	3
9	195- 104	WASHER - 3/8" flat	U&A
10	NSS	KEEPER - belt (no longer required)	1
11	C 18966	PULLEY - idler, flat	1
12	C 23531	PULLEY - idler V-groove	1
13	129- 103	NUT - 3/8" NC hex	2
14	C 23530	ARM AND BUSHING ASSEMBLY - belt tension, idler (used S/N 9686461 and after)	1
15	195- 2069	WASHER - 5/8" flat	1
16	132- 310	PIN - cotter 1/8" x 1"	1
17	C 15672	PULLEY - idler, flat	1
18	195- 104	WASHER - 3/8" flat	1
19	C 19553	SPRING - idler (used S/N 9686461 and after)	1
20	C 23516	PULLEY - V-groove (used S/N 9686461 and after)	1
21	126- 16	KEY - Woodruff #9 (used prior to S/N 9686461)	2
22	111- 202	BOLT - round head, square neck 5/16" x 3/4"	4
23	C 15514	FLANGETTE	4
24	192- 20	LOCKWASHER - 5/16"	4
25	129- 102	NUT - 5/16" NC hex	4
26	C 21681	BEARING - 3/4" bore	2
27	C 21795	LOCKING COLLAR AND SETSCREW	2
28	C 23467	JACKSHAFT ASSEMBLY (used S/N 9686461 and after)	1
29	C 18968	PULLEY - V-groove (used prior to S/N 9686461)	1
30	C 19688	KEEPER - belt	1
31	138- 2040	PIN - roll 1/4" x 1-1/4" (used S/N 9686461 and after)	1
32	C 23452	PULLEY - V-groove (used prior to S/N 9686461)	1
33	C 18981	JACKSHAFT - (used prior to S/N 9686461)	1
34	C 18969	ARM - belt tension idler (used prior to S/N 9686461)	1
35	C 18980	SPRING - idler (no longer required)	1
36	NSS	SPACER - jackshaft	1
37	C 23529	BUSHING - idler pivot (included in idler arm)	1
	C 23532	KIT - traction drive (required on all unmodified 210 tractors S/N 9686461 thru S/N 9701395) includes items 1, 12, 14, 20, 27, 28 and 31	1

CLUTCH, BELTS AND GUARD

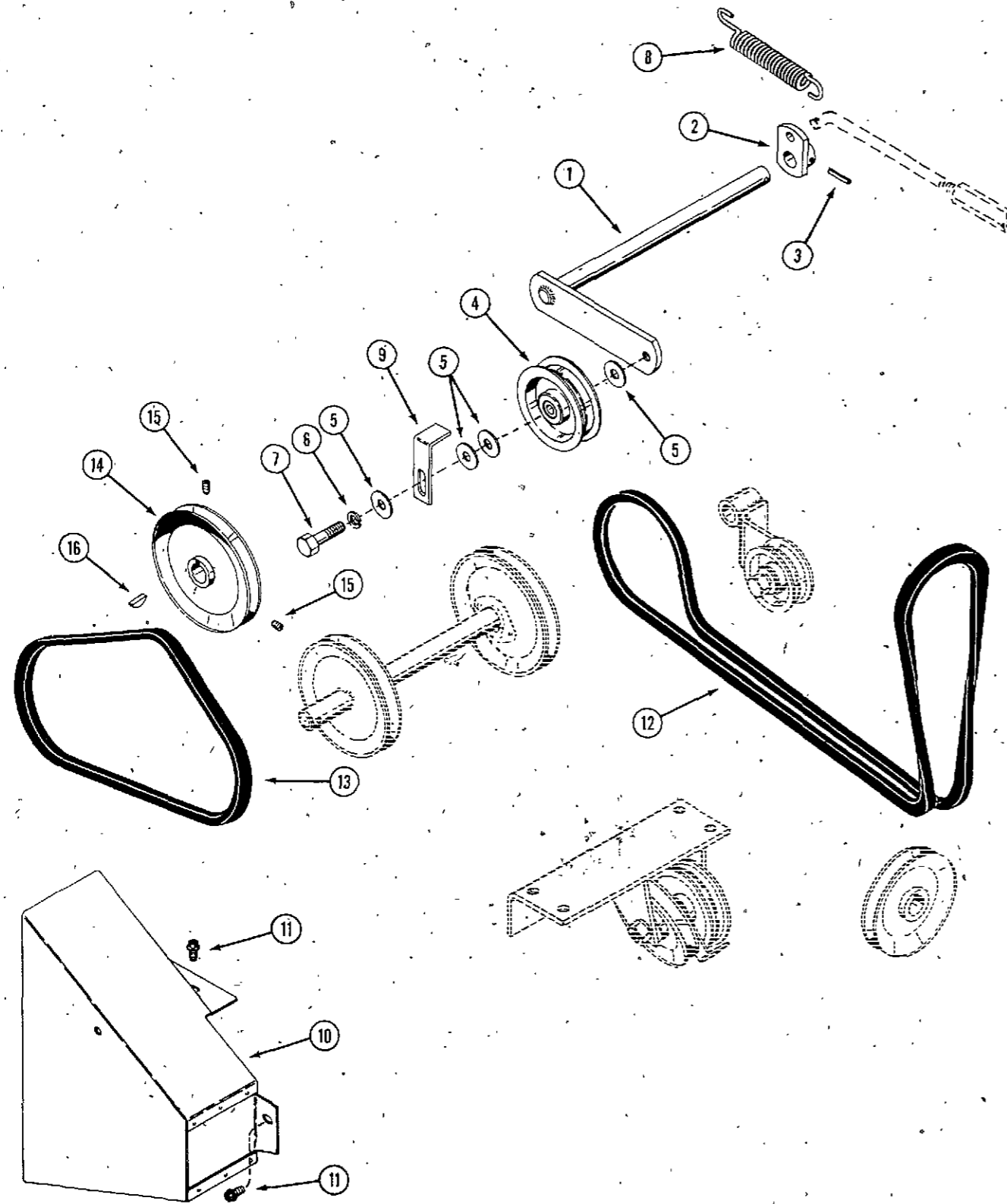

REF.	PART NO.	DESCRIPTION	REQ'D
1	C 18961	SHAFT - clutch idler	1
2	C 18964	LEVER - clutch	1
3	138- 96	PIN - roll 3/16" x 1"	1
4	C 15672	PULLEY - clutch idler	1
5	195- 104	WASHER - 3/8" flat	1
6	192- 21	LOCKWASHER - 3/8"	1
7	113- 233	BOLT - 3/8" x 1-3/4" NC hex.	1
8	C 19553	SPRING - clutch	1
9	C 17164	KEEPER - belt	1
10	C 19397	GUARD - belt	1
11	187- 1036	SCREW - 1/4" x 1/2" self tapping	4
12	C 23685	BELT - tractor drive	1
13	C 18919	BELT - clutching	1
14	C 18960	PULLEY - transaxle input	1
15	178- 858	SETSCREW - 5/16" x 3/8" knurled cup point	2
16	126- 16	KEY - Woodruff #9	1

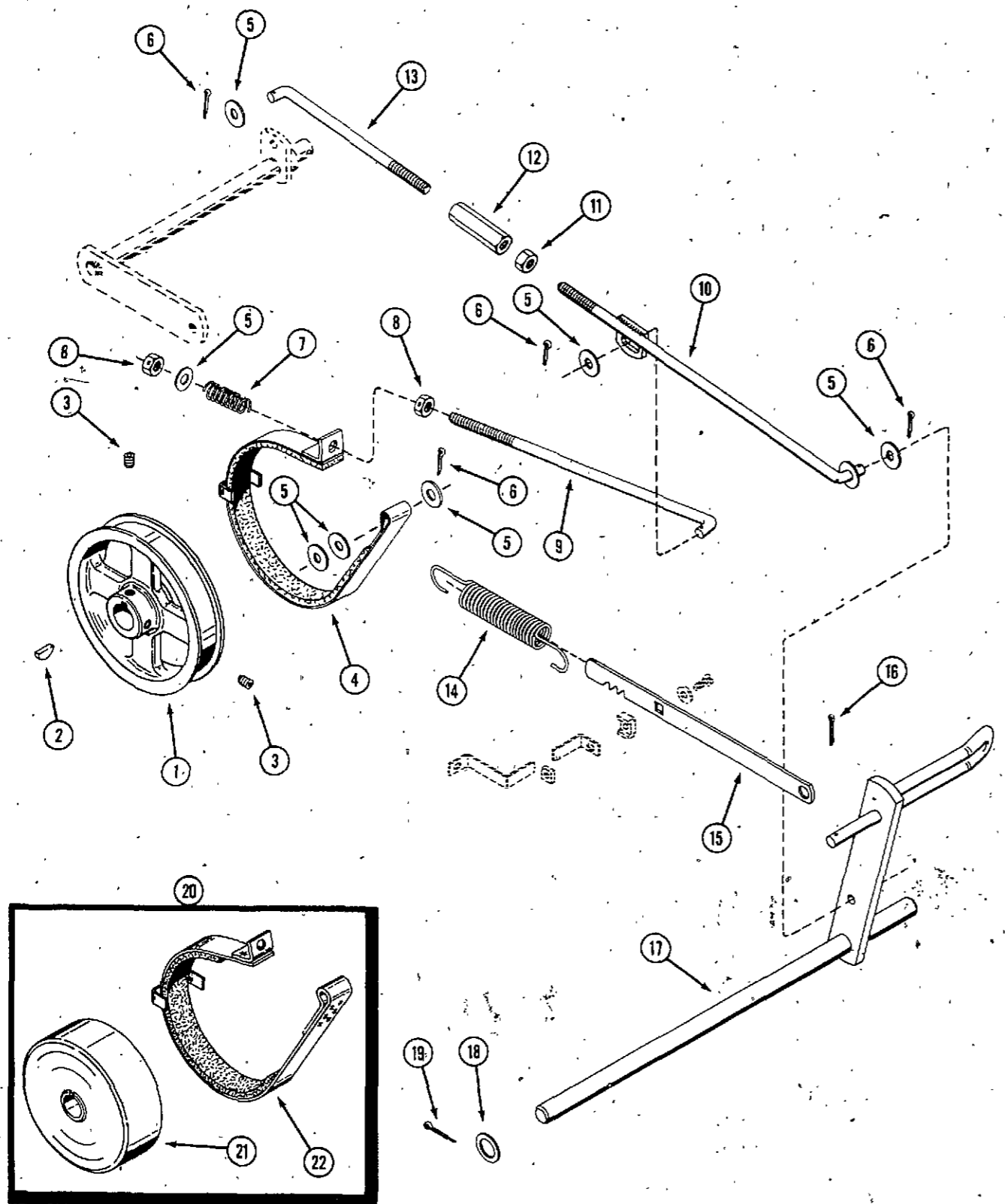

**BRAKE ASSEMBLY**

REF.	PART NO.	DESCRIPTION	REQ'D
1	NSS	DRUM - brake (on transaxle) (order C22048 Kit)	1
2	126- 16	KEY - Woodruff #9	1
3	178- 858	SETSCREW - 5/16" x 3/8" knurled cup point	1
4	C 21994	BAND ASSEMBLY - brake	1
5	195- 104	WASHER - 3/8" flat	7
6	132- 46	PIN - cotter 1/8" x 3/4"	4
7	L 32763	SPRING - compression	1
8	131- 178	LOCKNUT - 3/8" NC hex	2
9	C 18988	LINK - brake	1
10	C 18985	LINK - clutch, forward	1
11	129- 103	NUT - 3/8" NC hex	1
12	C 19552	TURNBUCKLE - 3/8" hex NC	1
13	C 18986	LINK - clutch, rear	1
14	C 16379	SPRING - brake lock	1
15	C 18147	LEVER - brake lock	1
16	132- 310	PIN - cotter	1
17	C 18983	PEDAL ASSEMBLY - brake/clutch	1
18	C 12975	WASHER - brake shaft	1
19	132- 336	PIN - cotter 1/8" x 3/4"	1
20	C 22048	KIT - brake	1
21	C 21587	DRUM ASSEMBLY - brake	1
22	C 21584	BAND ASSEMBLY - brake	1

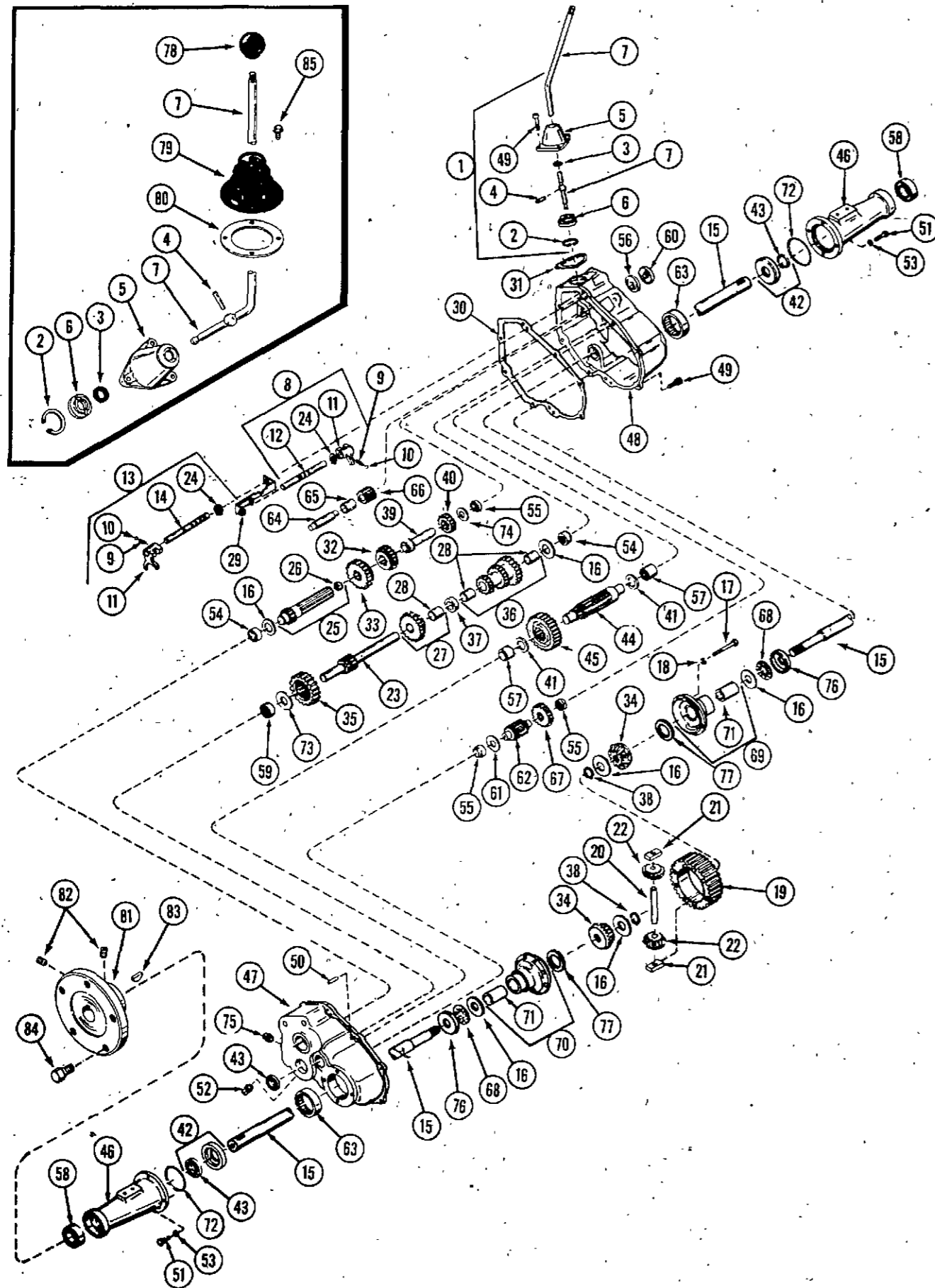

C 18956 TRANSAXLE

REF.	PART NO.	DESCRIPTION	REQ'D
1	C 19539	LEVER AND HOUSING ASSY. shift (Includes Ref. 2 thru 7)	1
2	C 11219	RING - snap	1
3	35012	RING - guard, shift lever	1
4	C 19324	PIN - shift lever	1
5	C 11162	HOUSING - shift lever	1
6	C 11163	KEEPER - shift lever	1
7	C 18957	LEVER - shift	1
8	C 11165	ROD ASSY. - shift (Includes Ref. 9 thru 12 and 24)	1
9	C 11166	SPRING	2
10	211- 5	BALL - steel	2
11	C 11167	FORK - shifter	2
12	C 11168	ROD - shifter (3rd and 4th)	1
13	C 11169	ROD ASSY. - shift (Includes Ref. 9, 10, 11 and 14)	1
14	C 11170	ROD - shifter (1st - 2nd and reverse)	1
15	C 11171	AXLE - transmission	2
16	C 11178	WASHER - thrust	5
17	13- 440	SCREW - 1/4" x 2-1/2" NC hex cap.	8
18	92- 4	LOCKWASHER - 1/4"	8
19	C 19540	GEAR - ring	1
20	C 11173	PIN - drive	1
21	C 11174	BLOCK - drive	2
22	C 19546	PINION - bevel	2
23	C 19536	SHAFT AND GEAR - brake	1
24	A 11538	RING - snap	2
25	C 11177	SHAFT AND BEARING ASSY. - pinion	1
26	A 27287	BEARING - pinion	1
27	C 11179	GEAR ASSEMBLY - cluster	1
28	C 11180	BUSHING - cluster gear	3
29	C 11181	STOP - shifter	1
30	C 11182	GASKET - case and cover	1
31	C 11183	GASKET - shift lever housing	1
32	C 11184	GEAR - shifting (3rd and 4th)	1
33	C 11185	GEAR - shifting (1st - 2nd and reverse)	1
34	C 19547	GEAR - bevel	2
35	C 11187	GEAR - idler	1
36	C 11188	GEAR ASSEMBLY - cluster (Includes two of Ref. 28)	1
37	C 11189	SPACER	1
38	C 11222	RING - snap	2
39	C 11190	SHAFT - input	1
40	C 11191	GEAR - spur, input shaft	1
41	C 11201	WASHER - thrust	2
42	C 11192	SEAL AND RETAINER - oil (Includes ref. 45)	2
43	C 11195	SEAL - oil	3
44	C 11194	PINION - output	1
45	C 11193	GEAR - output	1

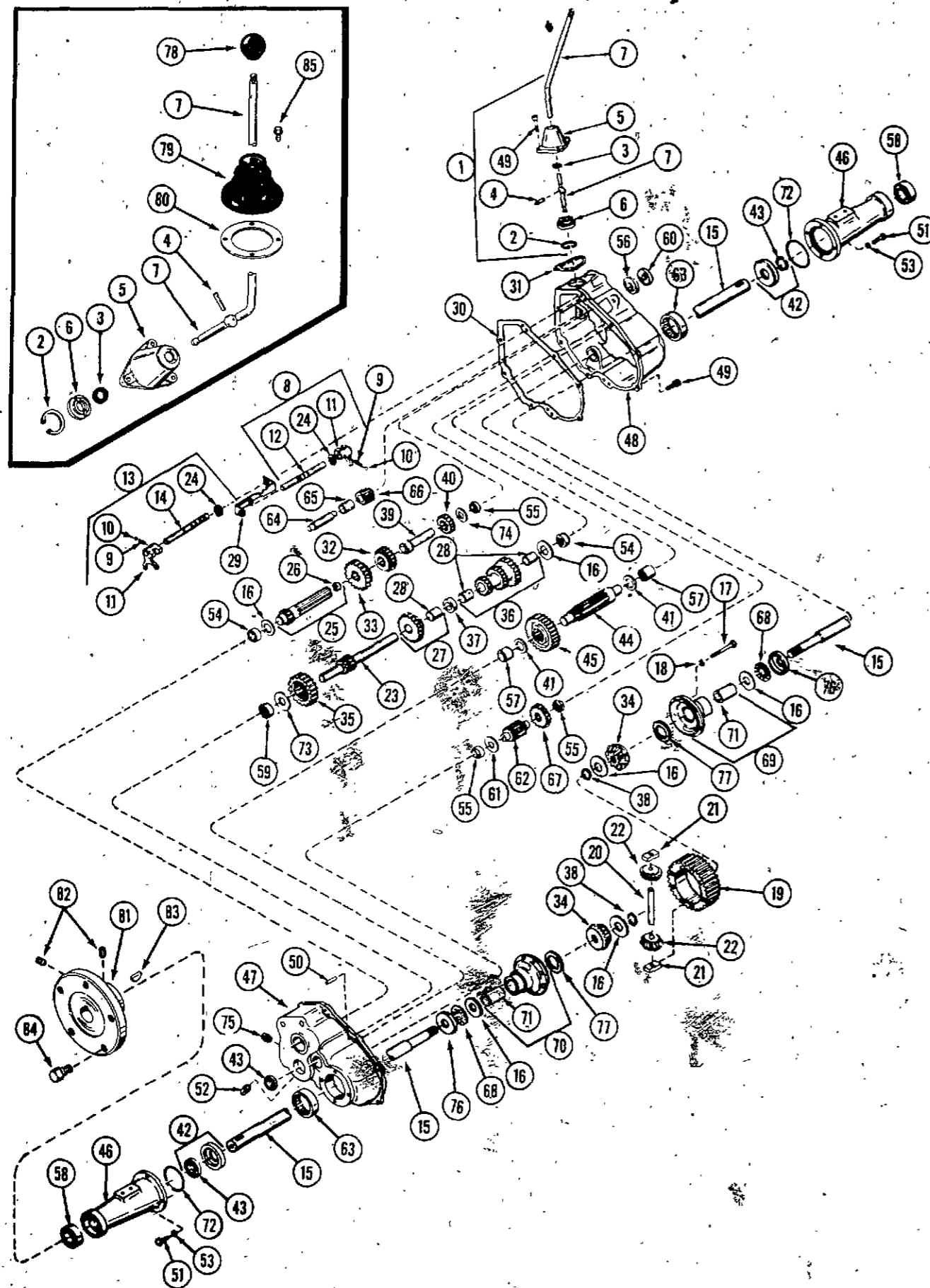

C 18956 TRANSAXLE

REF.	PART NO.	DESCRIPTION	REQ'D
46	C 11196	HOUSING - axle	2
47	C 19538	COVER ASSY. - transaxle (Includes ref. 54, 55, 57, 59 & 63).	1
48	C 19537	CASE ASSY. - transaxle (Includes ref. 54, 55, 57 & 63).	1
49	83- 412	SCREW - 1/4 x 3/4" NC socket head	11
50	F 53650	PIN - dowel	2
51	83- 514	SCREW - 5/16" x 7/8" NC hex	8
52	221- 672	PLUG - drain, magnetic	1
53	92- 5	LOCKWASHER - 5/16"	8
54	C 11200	BEARING - needle	2
55	A 27999	BEARING - needle	2
56	C 11202	BEARING - ball	1
57	C 11203	BEARING - needle	2
58	C 11204	BEARING - ball	2
59	A 12652	BEARING - needle	1
60	C 11206	SEAL - oil	1
61	C 11205	WASHER - thrust	1
62	C 11207	SHAFT AND PINION	1
63	R 21491	BEARING - needle	2
64	C 11209	SHAFT - idler, reverse	1
65	C 11210	SPACER - idler, reverse	1
66	C 11211	IDLER - reverse	1
67	C 11212	GEAR - spur	1
68	F 19633	BEARING - thrust	2
69	C 19541	CARRIER ASSY. - differential	1
70	C 19542	CARRIER ASSY. - differential	1
71	C 11216	BUSHING - carrier assembly	2
72	C 11208	"O" RING - axle housing	2
73	C 11223	WASHER - thrust	1
74	C 10822	WASHER - thrust	1
75	221- 13	PLUG - pipe	1
76	C 19544	RACE - thrust	2
77	C 19545	WASHER	2
78	C 10487	KNOB - shift lever	1
79	C 19448	BOOT - shift lever	1
80	C 19450	RING - boot mounting	1
81	C 10446	HUB - rear wheel	2
82	83- 68	SETSCREW - 3/8" x 1/2" NC soc.	4
83	126- 28	KEY - Woodruff #18	2
84	C 10314	BOLT - mounting, rear wheel	10
85	187- 1073	SCREW - 1/4" hex washer head - self tapping	4

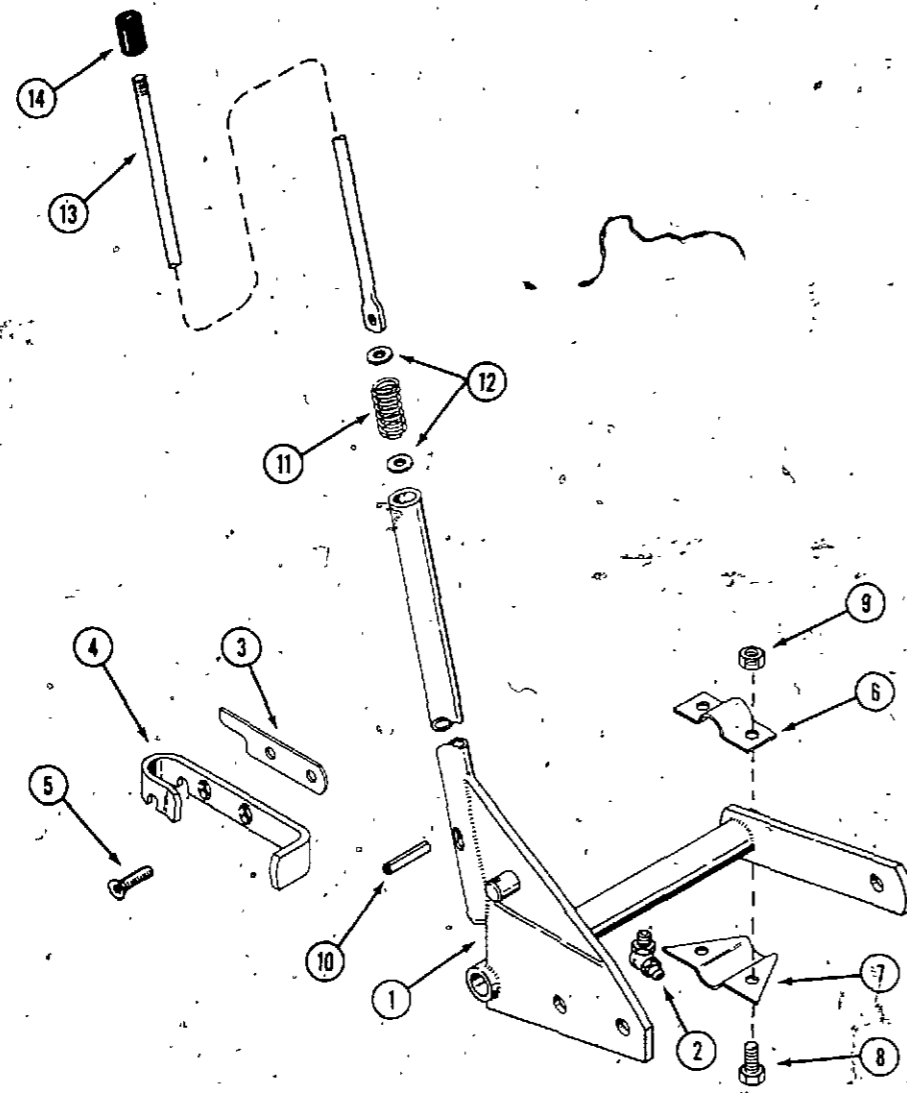

**IMPLEMENT LIFT**

REF.	PART NO.	DESCRIPTION	REQ'D
1	C 18809	LEVER ASSEMBLY - implement lift	1
2	219- 404	FITTING - lube 45°	1
3	C 17281	SPACER - latch	4
4	C 18811	LIFT - latch	1
5	164- 42	SCREW - 5/16 x 1-1/4" flat head socket	2
6	C 17249	BRACKET - mounting top	1
7	C 17250	BRACKET - mounting bottom	1
8	13- 614	BOLT - 3/8 x 7/8" NC hex	4
9	131- 178	NUT - lock 3/8"	4
10	138- 2054	PIN - spirol 5/16 x 1-3/4"	1
11	C 15564	SPRING - lift lever	1
12	195- 521	WASHER - 3/8 x 11/16" OD	2
13	C 17067	ROD - lift lever, push	1
14	C 14525	BUTTON - thumb	1
15	138- 2054	PIN - spirol 5/16 x 1-3/4"	1

**DRAWBAR AND TOW HITCH**

1	C 13360	DRAWBAR	1
2	192- 23	LOCKWASHER - 1/2" zinc plated	2
3	113- 424	BOLT - 1/2 x 1" NC hex zinc plated	2

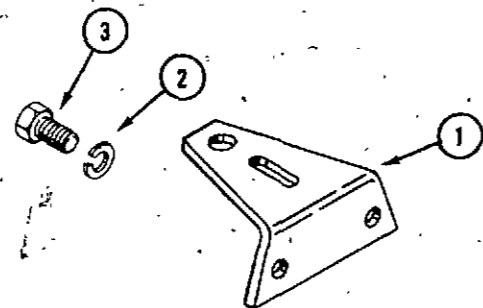

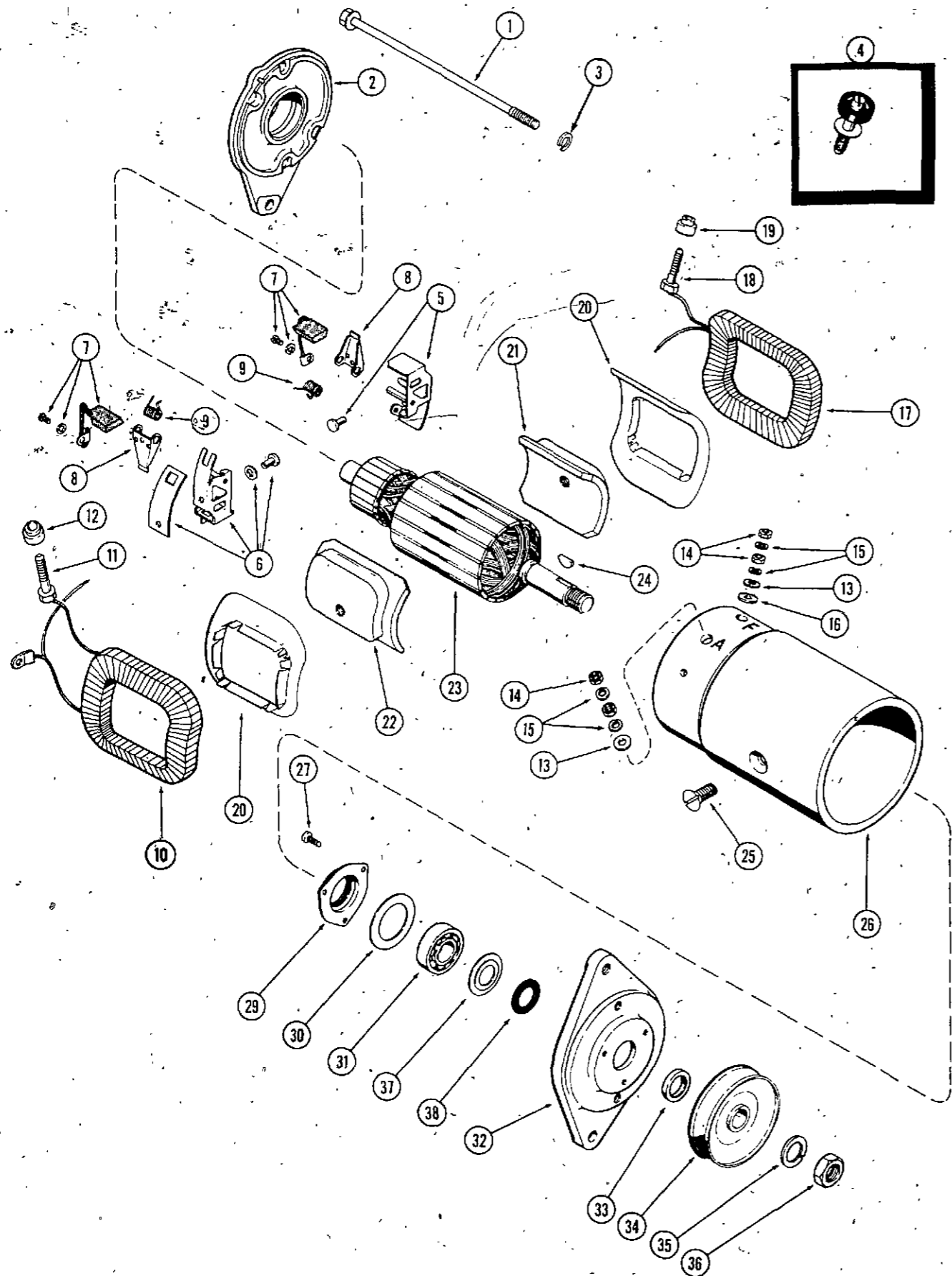

**C 16852 STARTER-GENERATOR  
(DELCO NUMBER 1101875)  
(USE A 70202 FOR SERVICE)**

REF.	PART NO.	DESCRIPTION	REQ'D
1	R 15106	BOLT - through	2
2	A 43494	FRAME ASSEMBLY - commutator end	1
3	192- 20	LOCKWASHER - 5/16"	2
4	A 40702	KIT - stud (Includes items 16, 18 and 19)	1
5	A 72039	HOLDER KIT - ground brush	1
6	A 72040	HOLDER KIT - insulated brush	1
7	A 72038	BRUSH ASSEMBLY	2
8	R 15090	ARM - brush pressure	2
9	R 16161	SPRING - brush arm	2
10	A 72042	COIL ASSEMBLY - field R.H.	1
11	A 72048	STUD - armature terminal	1
12	R 16147	BUSHING - insulated, armature stud	1
13	A 41927	WASHER - armature stud	2
14	129- 18	NUT - terminal stud 12-24 hex	4
15	192- 17	LOCKWASHER - terminal stud #12	4
16	R 16148	WASHER - insulated, field stud (Order A40702)	1
17	A 72043	COIL ASSEMBLY - field L.H.	1
18	NSS	STUD - field terminal (Order A40702)	1
19	R 15077	BUSHING - insulated, field stud (Order A40702)	1
20	A 25447	INSULATOR - field coil	2
21	A 40736	SHOE - pole	1
22	A 40736	SHOE - pole	1
23	A 43495	ARMATURE	1
24	126- 111	KEY - Woodruff, armature	1
25	A 42127	SCREW - pole	2
26	NSS	BODY - starter, generator (Order A70202)	1
27	A 41959	SCREW - 10-32 x 1/2" round head	3
29	A 44433	RETAINER ASSEMBLY - bearing	1
*30	NSS	GASKET - bearing retainer (order A44433)	1
31	A 43356	BEARING - ball, drive end	1
32	A 72046	FRAME ASSEMBLY - drive end	1
33	A 72047	SPACER - pulley	1
34	C 14344	PULLEY - starter, generator drive	1
35	192- 116	LOCKWASHER - 11/16" plated	1
36	A 25546	NUT - armature shaft, drive end	1
37	A 43499	RETAINER - grease	1
*38	NSS	SEAL - felt (Order A44433)	1

\* Bearing retainer gasket and felt seal not required when servicing with retainer assembly.  
Bearing retainer assembly services all starters.

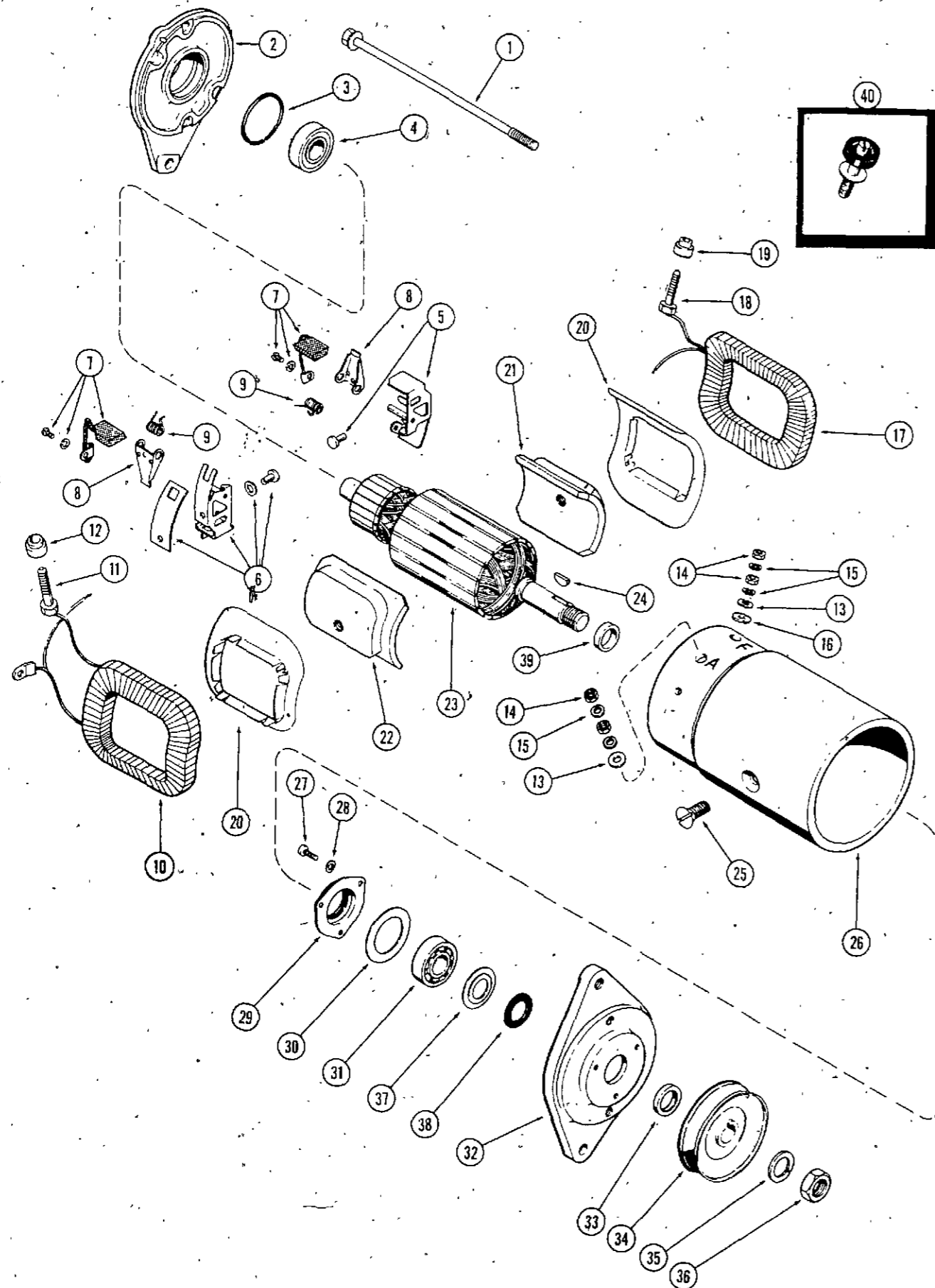

**A 70202 STARTER-GENERATOR  
(DELCO NUMBER 1101970)**

REF.	PART NO.	DESCRIPTION	REQ'D
1	R 15106	BOLT - through (Includes washer)	2
2	A 72104	FRAME ASSEMBLY - commutator end	1
3	R 15087	RING - bearing retainer	1
4	A 25461	BEARING - commutator end ball	1
5	A 72039	HOLDER KIT - ground brush	1
6	A 72040	HOLDER KIT - insulated brush	1
7	A 72038	BRUSH ASSEMBLY	2
8	R 15090	ARM - brush pressure	2
9	R 16161	SPRING - brush arm	2
10	A 72042	COIL ASSEMBLY - field R.H.	1
11	A 72048	STUD - armature terminal	1
12	R 16147	BUSHING - insulated, armature stud	1
13	A 41927	WASHER - armature stud	2
14	129- 18	NUT - terminal stud 12-24 hex	4
15	192- 17	LOCKWASHER - terminal stud #12	4
16	R 16148	WASHER - insulated, field stud	1
17	A 72043	COIL ASSEMBLY - field L.H.	1
18	NSS	STUD - field terminal (See Ref. 40)	1
19	R 15077	BUSHING - insulated, field stud (Order A40702)	1
20	A 25447	INSULATOR - field coil	2
21	A 40736	SHOE - pole, plain	1
22	A 40736	SHOE - pole, notched	1
23	A 72041	ARMATURE	1
24	126- 111	KEY - Woodruff, armature	1
25	74- 610	SCREW - pole	2
26	NSS	BODY - starter, generator (Order A70202)	1
27	173- 237	SCREW - 10-32 x 1/2" rd. hd.	3
28	192- 18	LOCKWASHER - 3/16" plated	3
29	A 44433	RETAINER ASSEMBLY - bearing	1
30	NSS	GASKET - bearing retainer (order A44433)	1
31	A 25441	BEARING - ball, drive end	1
32	A 72046	FRAME ASSEMBLY - drive end	1
33	A 72047	SPACER - pulley	1
34	C 14344	PULLEY - starter, generator drive	1
35	192- 26	LOCKWASHER - 11/16" plated	1
36	A 25546	NUT - armature shaft, drive end	1
37	A 43499	RETAINER - grease	1
38	NSS	SEAL - felt (Order A44433)	1
39	NSS	SPACER - armature shaft, inner	1
40	A 40702	KIT - stud (Includes items 16, 18 and 19)	1

\* Bearing retainer gasket and felt seal not required when servicing with retainer assembly. Bearing retainer assembly services all starters.



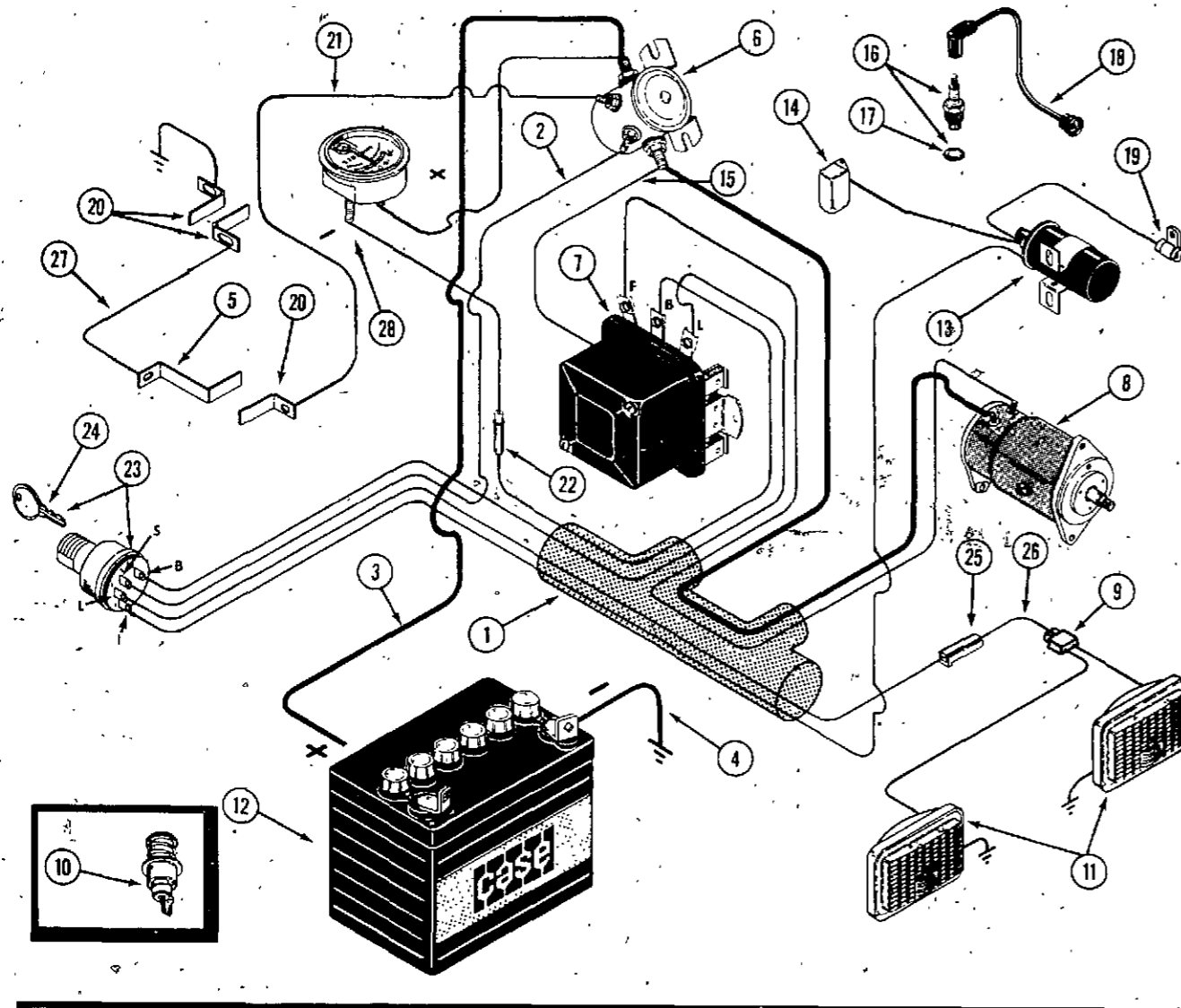

CASE MODEL 210 COMPACT TRACTOR

ELECTRICAL SYSTEM

REF.	PART NO.	DESCRIPTION	REQ'D
1	C 21948	HARNES - wire	1
2	C 17187	WIRE - ignition switch to solenoid (yellow 8")	1
3	C 14565	CABLE - battery to solenoid (red 10-1/2")	1
4	C 14566	CABLE - battery to ground (black 12")	1
5	C 18998	SWITCH - strip	1
6	C 14553	SOLENOID - start	1
7	A 70221	REGULATOR - voltage, 12 volt	1
8	C 16852	STARTER - generator 12 V. (Repairs page 45) Delco No. 1101875	1
8	A 70202	STARTER - generator 12 V. (Repairs page 47) Delco No. 1101970	1
9	C 14537	CONNECTOR - headlamp	1
10	C 17186	LAMP ASSEMBLY - warning (used prior to S/N 9701679)	1
	B 50213	BULB - generator indicator (red)	1
11	C 22571	HEADLAMP ASSEMBLY - 12 Volt (Repairs page 51)	2
12	C 18197	BATTERY - 12 volt	1
13	KO 231281	COIL - ignition 12 volt	1
14	KO 232535	COVER - breaker contacts	1
15	C 17275	WIRE - regulator ground to solenoid (white 7")	1
16	M 20007	SPARK PLUG - (Includes gasket)	1
17	A 27251	GASKET - spark plug	1
18	KOA235095	CABLE - high tension	1
19	KO 230722	CONNECTOR	1
20	C 18115	SWITCH - strip	1
21	C 19055	WIRE - solenoid to safety switch (black 17")	3
22	223- 20	FUSE - 20 amp	1
23	C 21595	SWITCH - ignition (includes key)	1
24	C 17763	KEY - ignition	1
25	C 19286	CONNECTOR - headlight extension	1
26	C 19287	WIRE - headlight extension	1
27	C 18203	WIRE - PTO switch to clutch switch (black 14")	1
28	C 18389	AMMETER (used S/N 9701679 and after)	1

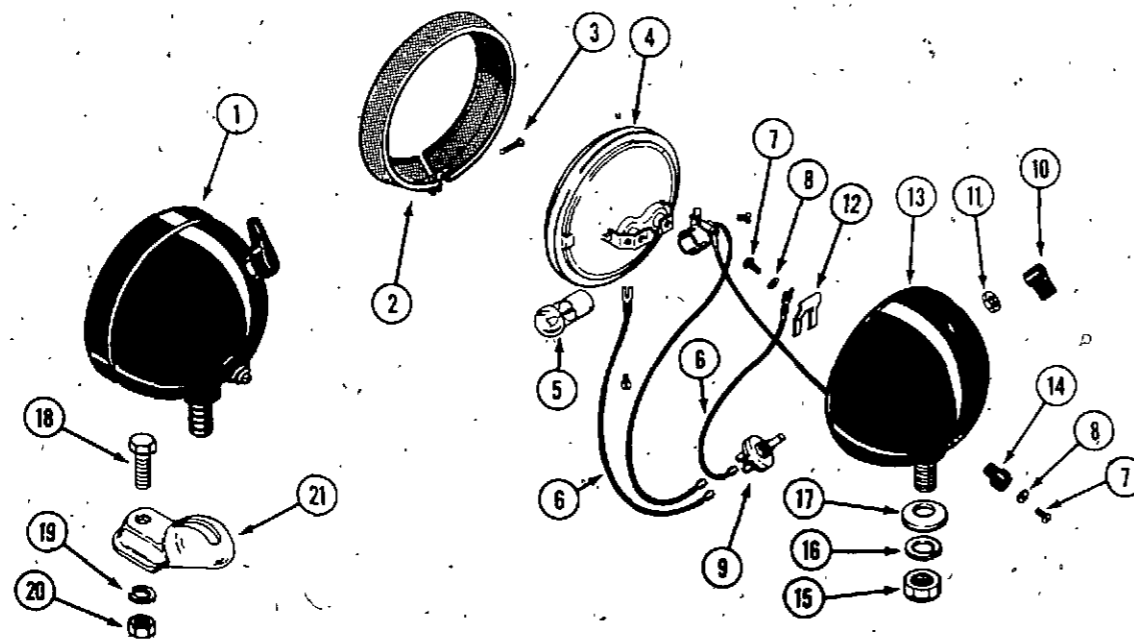

TAIL LAMP (Optional)

1	A 20965	LAMP ASSEMBLY - flood and tail	1
2	B 50255	MOLDING - lamp retaining	1
3	10934	SCREW - molding	1
4	A 40855	LAMP - sealed unit	1
5	B 50223	BULB - red 15 C. P. 12 volt	1
6	B 50273	WIRE - switch	2
7	173- 73	SCREW - wire	2
8	193- 4	WASHER - 1/4" lock	2
9	NSS	SWITCH (See Kit below)	1
10	NSS	KNOB - switch (See Kit below)	1
11	B 50224	NUT - stitch	1
12	10927	SPRING - terminal	1
13	NSS	BODY	1
14	B 50293	TERMINAL - wire	1
15	129- 105	NUT - 1/2" NC hex	1
16	192- 23	WASHER - 1/2" lock	1
17	10923	WASHER - bearing	1
18	113- 209	BOLT - 3/8 x 1-1/2" NC hex, zinc plated	1
19	192- 21	LOCKWASHER - 3/8" zinc plated	1
20	129- 103	NUT - 3/8" NC hex, zinc plated	1
21	A 34046	BRACKET - mounting, tail lamp	1
	A 43182	KIT - switch (includes knob)	1

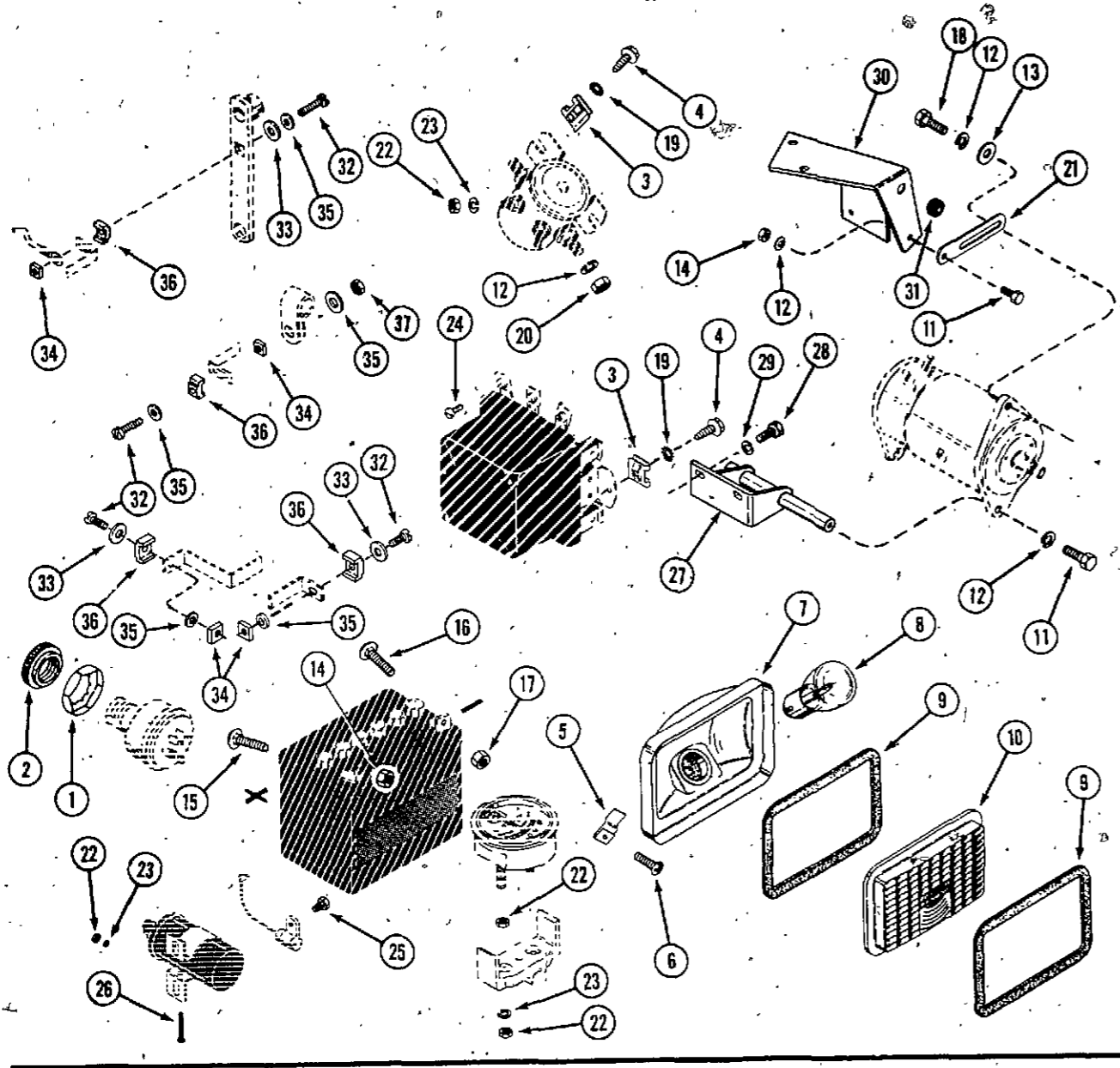

**ELECTRICAL SYSTEM HARDWARE**

REF.	PART NO.	DESCRIPTION	REQ'D
1	C 14060	NUT - back up 3/4"	1
2	C 17921	NUT - escutcheon 3/4"	1
3	C 10836	NUT - speed type "U"	4
4	187- 485	SCREW - #10 x 5/8" Self-Tapping Hex. Zinc Plated	4
5	131- 629	NUT - speed type "U"	4
6	187- 1047	SCREW - #8 x 1/2" Self-Tapping round head, Phillips	4
	C 22571	HEADLAMP ASSEMBLY	2
7	NSS	RECEPTACLE - headlamp (Order C22571)	1
8	C 14305	BULB - headlamp	1
9	C 14304	GASKET - headlamp	2
10	C 22573	LENS - headlamp	1
11	113- 103	BOLT - 5/16 x 1" NC hex, zinc plated	2
12	193- 29	LOCKWASHER - 5/16" internal tooth	5
13	195- 520	WASHER - 5/16" plain, zinc plated	2
14	129- 102	NUT - 5/16" NC hex, zinc plated	2
15	111- 202	BOLT - 5/16 x 3/4" NC, rd. hd., square neck (batt. positive)	1
16	111- 108	BOLT - 1/4 x 3/4" NC, rd. hd., square neck (batt. negative)	1
17	129- 101	NUT - 1/4" NC hex	1
18	113- 102	BOLT - 5/16 x 3/4" NC hex, zinc plated	1
19	193- 70	LOCKWASHER - #10 external tooth	4
20	129- 122	NUT - 5/16" NF hex	2
21	C 14599	BRACKET - starter generator adjust	1
22	129- 27	NUT - #10 NF hex	8
23	192- 18	LOCKWASHER - #10	6
24	169- 131	SCREW - #8 x 5/16" NC fillister head	3
25	22- 58	BOLT - 5/16 x 1/2" NC hex, Self-Tapping	2
26	187- 1844	SCREW - #10 x 1-1/2" UNF Self-Tapping	2
27	C 18788	SUPPORT - starter generator	1
28	13- 612	BOLT - 3/8 x 3/4" NC hex	2
29	192- 21	LOCKWASHER - 3/8"	2
30	C 18999	SUPPORT - starter generator adjust	1
31	C 17546	GROMMET - wire	1
32	182- 523	SCREW - #10 x 7/8" binder head	4
33	C 19254	WASHER - nylon 13/64"	3
34	129- 77	NUT - #10 - 32 square	4
35	195- 513	WASHER - #10	5
36	C 19246	HOLDER - strip switch	4
37	129- 37	NUT - #10 - 32 hex	1
	C 19521	CLIP - wire holder	1

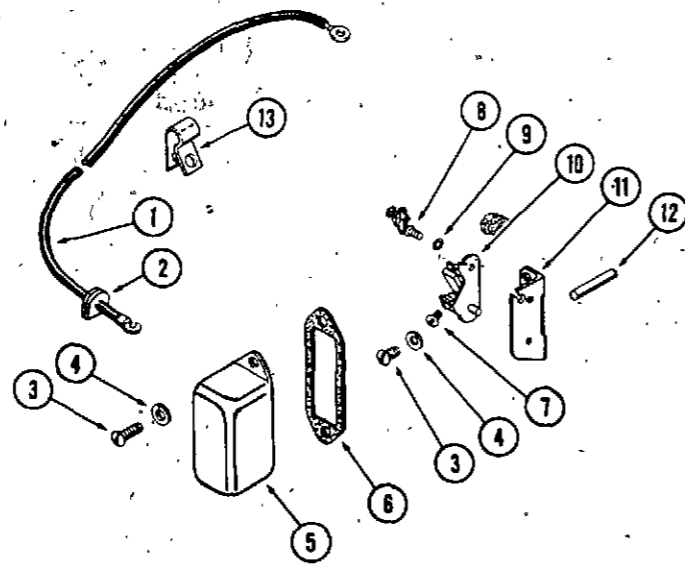

**BREAKER CONTACTS**

1	KOA231533	LEAD - breaker contact (Includes grommet)	1
2	KO 220297	GROMMET - contact lead	1
3	173- 210	SCREW - #10 x 3/8" round head, zinc plated	4
4	192- 18	LOCKWASHER - 3/16" zinc plated	4
5	KO 232535	COVER - breaker contact	1
6	KO 220174	GASKET - cover	1
7	187- 408	SCREW - #6 x 3/8" Self-Tapping	1
8	173- 224	SCREW - #8 x 1/4" NC round head	1
9	193- 5	LOCKWASHER - #8 internal tooth	1
10	KO 220980	POINT SET - breaker contact	1
11	KOA220981	BRACKET - breaker contact	1
12	KOX 489-1	ROD - breaker contact push	1
13	KO 275182	CLIP - wire	1

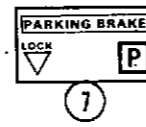
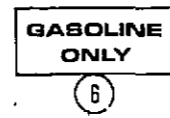
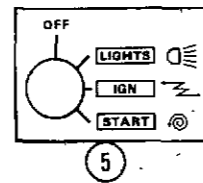
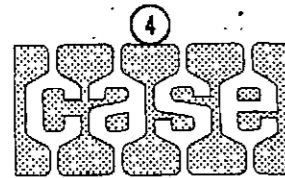
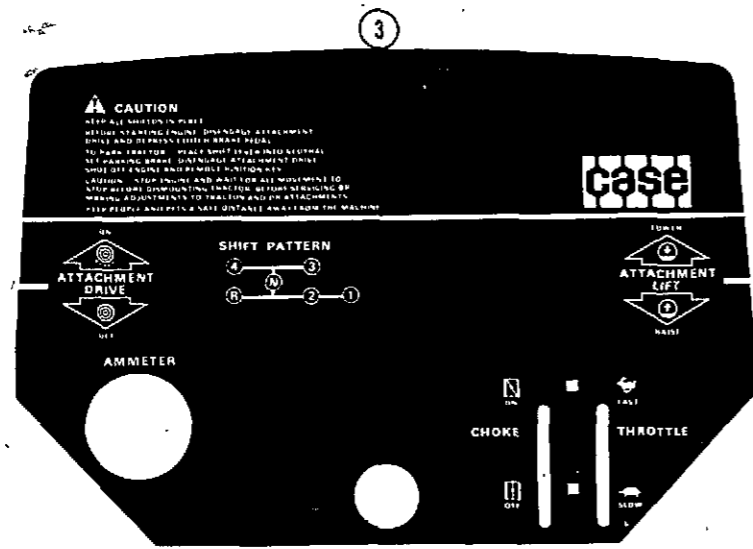

DECALS

REF.	PART NO.	DESCRIPTION	REQ'D
1	321- 2499	DECAL - hood L.H.	1
2	321- 2498	DECAL - hood R.H.	1
3	321- 2502	DECAL - instrument panel (used prior to S/N 9701679)	1
3	321- 3003	DECAL - instrument panel (used S/N 9701679 and after)	1
4	321- 1423	DECAL - "CASE" on seat back.	1
5	321- 1786	DECAL - ignition switch	1
6	C 14066	DECAL - gasoline	1
7	321- 2110	DECAL - parking brake	1

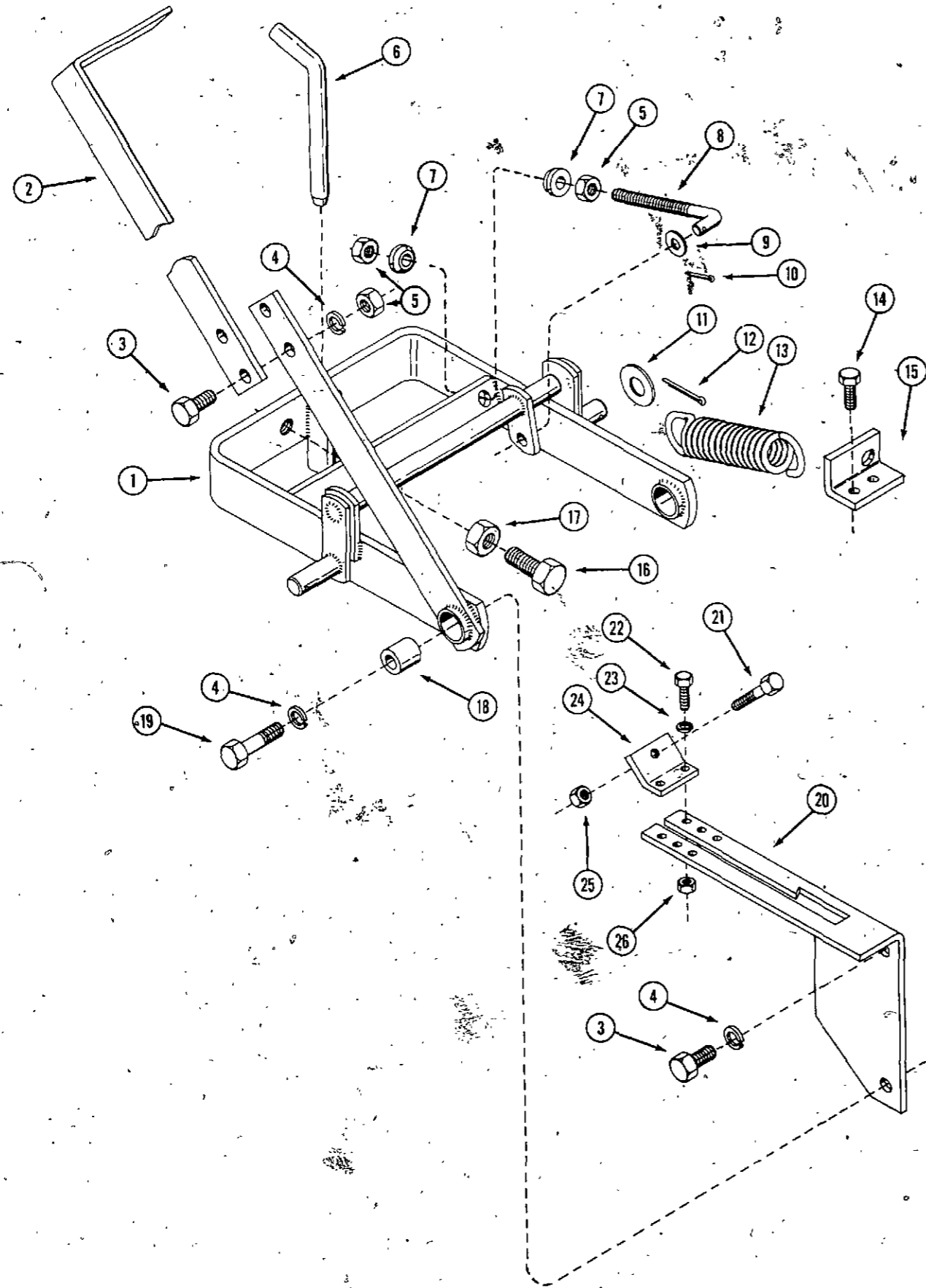

J 21 SLEEVE HITCH

REF.	PART NO.	DESCRIPTION	REQ'D
1	C 19514	HITCH ASSEMBLY	1
2	C 19497	HANDLE - lift	1
3	113- 424	BOLT - 1/2" NC x 1" hex	1
4	192- 23	LOCKWASHER - 1/2"	3
5	129- 105	NUT - 1/2" NC hex	5
6	C 14568	PIN - drawbar	4
7	C 16097	WASHER - domed	1
8	C 19502	J-BOLT - adjusting	2
9	195- 529	WASHER - 7/16" flat	1
10	132- 48	PIN - cotter 1/8" x 1"	1
11	195- 545	WASHER - 3/4" flat	1
12	132- 306	PIN - cotter 3/16" x 1-3/4"	2
13	C 19501	SPRING - assist	2
14	113- 207	BOLT - 3/8" NC x 1" (Replaces transaxle mounting bolts) when attaching spring brackets	2
15	C 19516	BRACKET - spring attaching L.H. shown	4
	C 19517	BRACKET - spring attaching R.H. not shown	1
16	113- 607	BOLT - 5/8" NC 1-1/2" hex	1
17	129- 107	NUT - 5/8" NC hex	2
18	C 19499	SLEEVE - pivot	2
19	113- 421	BOLT - 1/2" NC x 2" hex	2
20	C 19496	LATCH - hitch	2
21	113- 257	BOLT - 3/8" NC x 2-1/2" hex	1
22	113- 103	BOLT - 5/16" NC x 1" hex	1
23	192- 20	LOCKWASHER - 5/16"	2
24	C 19498	BRACKET - lift stop	2
25	129- 103	NUT - 3/8" hex	1
26	129- 102	NUT - 5/16" hex	1

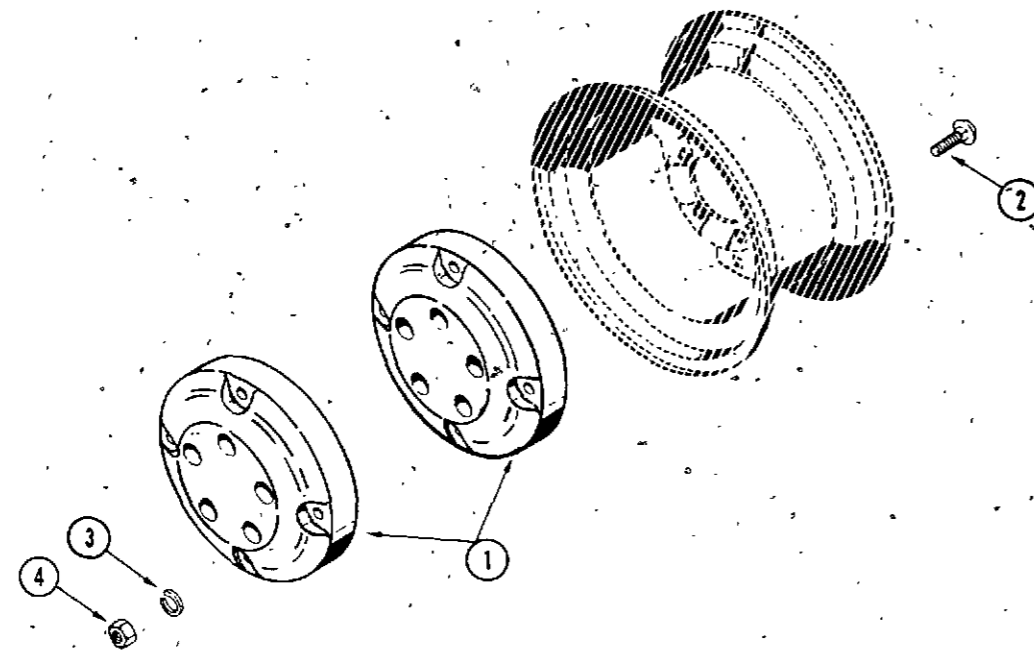

### D8 WHEEL WEIGHTS

REF.	PART NO.	DESCRIPTION	REQ'D
1.	NSS	WEIGHT - wheel 12" (Order as Machinery Item)	4
2.	111- 532	BOLT - 1/2 x 3/4" round head, square neck, NC, zinc plated	8
3.	192- 23	LOCKWASHER - 1/2" zinc plated	8
4.	129- 105	NUT - 1/2" NC hex	8

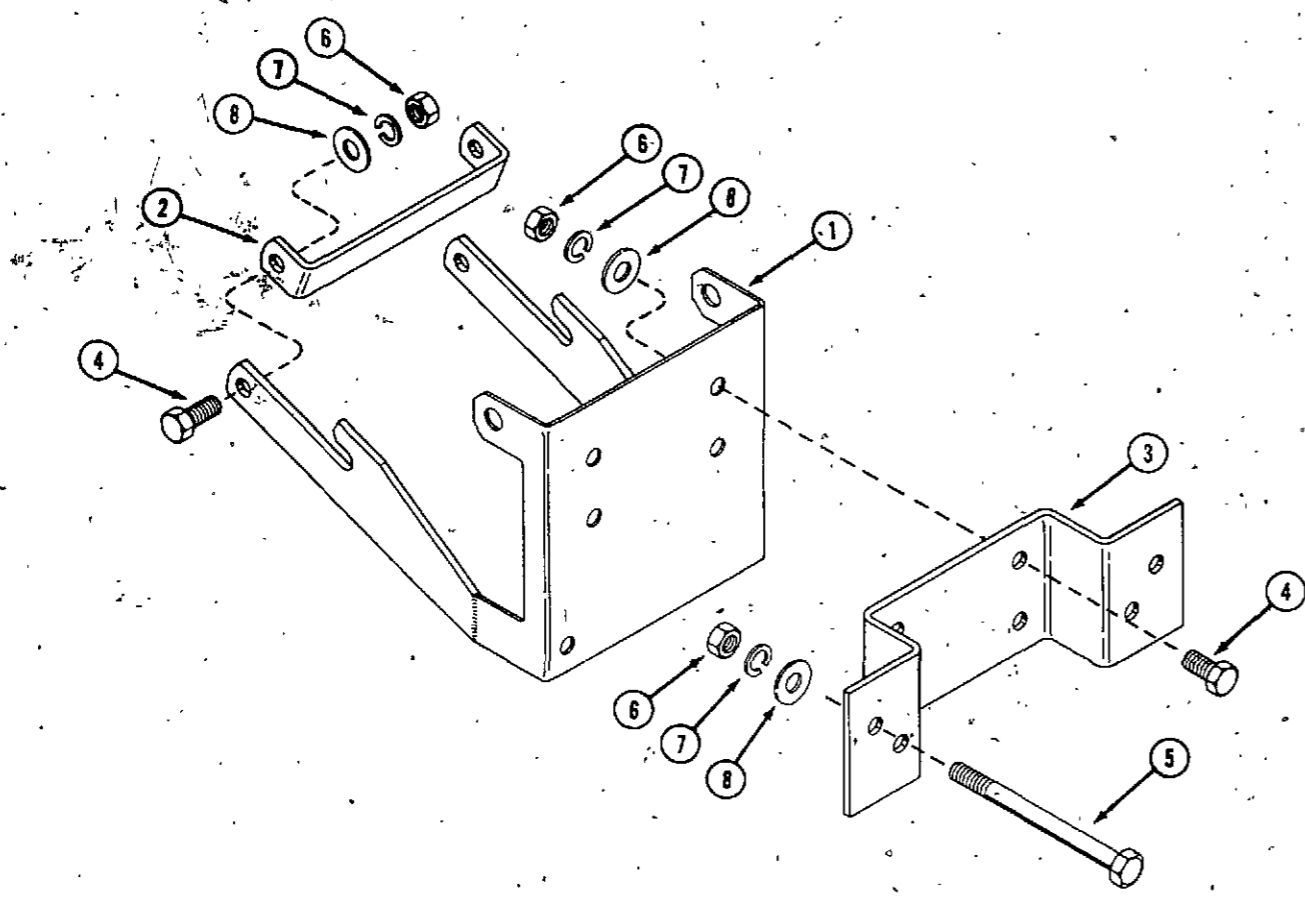

MODEL H18 FRONT END WEIGHT BRACKETS

REF.	PART NO.	DESCRIPTION	REQ'D
1	C 16581	BRACKET - mounting	1
2	C 17161	BRACE - rear	1
3	C 17162	BRACKET - weight mounting	1
4	113- 417	BOLT - 1/2 x 1-1/4" NC hex, zinc plated	6
5	113- 443	BOLT - 1/2 x 6-1/2" NC hex	2
6	25- 108	NUT - 1/2" NC hex, zinc plated	8
7	192- 23	LOCKWASHER - 1/2"	8
8	195- 533	WASHER - 1/2" zinc plated	8

MODEL H13 WEIGHT BOX

1	C 17859	FRAME - weight box	1
2	C 17863	BOX - weight	1
3	C 17860	SUPPORT - weight box	1
4	C 17636	PLATE - hitch	1
5	111- 317	BOLT - 3/8 x 1" round head, square neck	3
6	113- 207	BOLT - 3/8 x 1" NC hex	4
7	129- 103	NUT - 3/8" NC hex	7
8	192- 21	LOCKWASHER - 3/8"	7
9	195- 525	WASHER - 3/8"	7

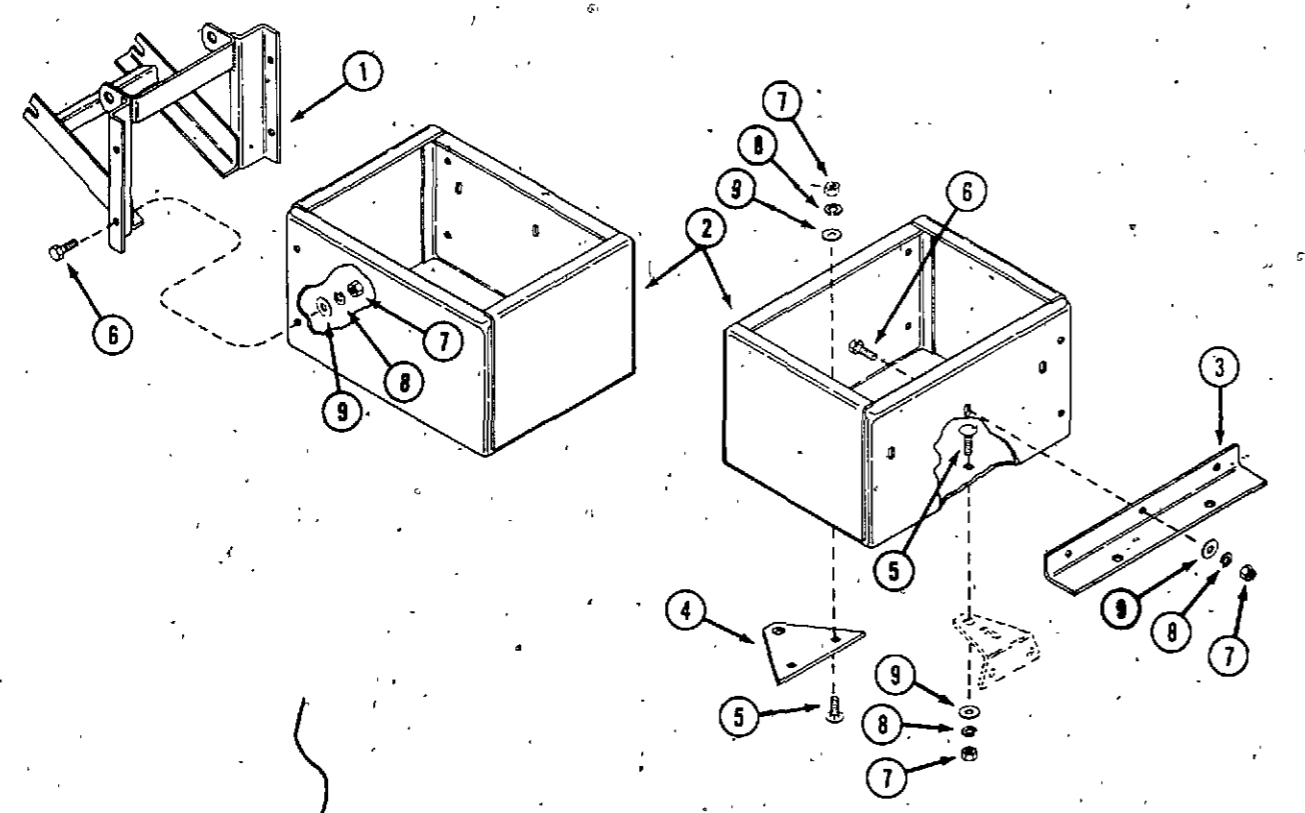

## NUMERICAL INDEX

PART NO.	PAGE NO.	REF. NO.	PART NO.	PAGE NO.	REF. NO.	PART NO.	PAGE NO.	REF. NO.
A	10923	49	A	72042	47	C	11180	39
A	10927	49	A	72043	45	C	11181	39
A	10934	49	A	72043	47	C	11182	39
A	35012	39	A	72046	45	C	11183	39
A	40035	9	A	72046	47	C	11184	39
A	40035	11	A	72047	45	C	11185	39
A	10326	19	A	72047	47	C	11187	39
A	11538	39	A	72048	45	C	11188	39
A	12652	41	A	72048	47	C	11189	39
A	20965	49	A	72073	15	C	11190	39
A	23603	11	A	72073	17	C	11191	39
A	25441	47	A	72077	17	C	11192	39
A	25447	45	A	72078	17	C	11193	39
A	25447	47	A	72079	17	C	11194	39
A	15461	47	A	72080	17	C	11195	39
A	25546	45	A	72083	17	C	11196	41
A	25546	47	A	72084	17	C	11200	41
A	27001	9	A	72092	17	C	11201	39
A	27251	49	A	72099	17	C	11202	41
A	27287	39	A	72100	13	C	11203	41
A	27365	11	A	72100	15	C	11204	41
A	27999	41	A	72103	17	C	11205	41
A	30881	29	A	72104	47	C	11206	41
A	34046	49	A	72108	13	C	11207	41
A	37247	21	A	72108	15	C	11208	41
A	39519	21	A	72108	17	C	11208	41
A	40702	45	B	50213	49	C	11209	41
A	40702	47	B	50223	49	C	11210	41
A	40736	45	B	50224	49	C	11211	41
A	40736	45	B	50255	49	C	11212	41
A	40736	47	B	50273	49	C	11216	41
A	40736	47	B	50293	49	C	11219	39
A	40855	49	B	53393	13	C	11222	39
A	41927	45	C	10263	29	C	11223	41
A	41927	47	C	10314	29	C	11529	15
A	41959	45	C	10314	41	C	11545	15
A	42127	45	C	10446	41	C	11906	29
A	43182	49	C	10487	41	C	12081	29
A	43356	45	C	10657	15	C	12110	29
A	43494	45	C	10678	15	C	12111	29
A	43495	45	C	10822	41	C	12224	19
A	44433	45	C	10836	51	C	12370	29
A	44433	47	C	11162	39	C	12975	29
A	70062	29	C	11163	39	C	12975	31
A	70090	5	C	11165	39	C	12975	37
A	70185	29	C	11166	39	C	13106	29
A	70202	49	C	11167	39	C	13360	43
A	70221	49	C	11168	39	C	14060	51
A	72038	45	C	11169	39	C	14066	53
A	72038	47	C	11170	39	C	14157	15
A	72039	45	C	11171	39	C	14200	31
A	72039	47	C	11173	39	C	14201	31
A	72040	45	C	11174	39	C	14295	23
A	72040	47	C	11177	39	C	14304	51
A	72041	47	C	11178	39	C	14305	51
A	72042	45	C	11179	39	C	14344	45
						C	14344	47

## NUMERICAL INDEX

PART NO.	PAGE NO.	REF. NO.	PART NO.	PAGE NO.	REF. NO.	PART NO.	PAGE NO.	REF. NO.
C	14345	11	C	17249	43	C	18980	33
C	14399	11	C	17250	43	C	18981	33
C	14506	19	C	17275	49	C	18983	37
C	14525	43	C	17281	43	C	18985	37
C	14534	27	C	17546	51	C	18986	37
C	14537	49	C	17636	59	C	18988	37
C	14553	49	C	17717	19	C	18989	15
C	14565	49	C	17718	19	C	18992	31
C	14566	49	C	17763	49	C	18996	27
C	14568	55	C	17859	59	C	18998	49
C	14599	51	C	17860	59	C	18999	51
C	14690	15	C	17863	59	C	19021	15
C	14906	11	C	17921	51	C	19053	5
C	14906	21	C	18014	31	C	19055	49
C	14953	11	C	18016	31	C	19204	23
C	15007	15	C	18017	31	C	19213	5
C	15096	31	C	18097	9	C	19246	51
C	15410	27	C	18097	11	C	19254	51
C	15514	33	C	18097	13	C	19283	25
C	15515	23	C	18098	19	C	19286	49
C	15556	23	C	18099	19	C	19287	49
C	15557	23	C	18101	9	C	19324	39
C	15564	43	C	18103	19	C	19397	35
C	15672	33	C	18115	49	C	19417	27
C	15672	35	C	18147	37	C	19448	41
C	15718	23	C	18150	25	C	19449	5
C	15719	23	C	18153	25	C	19450	41
C	15721	23	C	18197	49	C	19472	23
C	16097	55	C	18203	49	C	19496	55
C	16129	27	C	18389	49	C	19497	55
C	16170	25	C	18711	31	C	19498	55
C	16200	31	C	18733	25	C	19499	55
C	16239	25	C	18777	29	C	19501	55
C	16362	25	C	18779	29	C	19502	55
C	16363	15	C	18788	51	C	19514	55
C	16364	25	C	18793	19	C	19516	55
C	16373	25	C	18809	43	C	19517	55
C	16374	25	C	18811	43	C	19521	51
C	16379	37	C	18812	29	C	19536	39
C	16404	27	C	18814	11	C	19537	41
C	16429	27	C	18890	25	C	19538	41
C	16446	27	C	18907	23	C	19539	39
C	16447	27	C	18908	23	C	19540	39
C	16448	19	C	18918	35	C	19541	41
C	16449	19	C	18919	35	C	19542	41
C	16581	59	C	18940	23	C	19544	41
C	16692	31	C	18940	25	C	19545	41
C	16786	23	C	18940	25	C	19546	39
C	16796	15	C	18957	39	C	19547	39
C	16852	49	C	18960	33	C	19552	37
C	17067	43	C	18960	35	C	19553	33
C	17152	27	C	18961	35	C	19553	35
C	17161	59	C	18964	35	C	19688	33
C	17162	59	C	18966	33	C	19767	21
C	17164	33	C	18968	33	C	19802	23
C	17164	35	C	18969	33	C	19867	21
C	17164	35	C	18974	33	C	19869	33
C	17186	49	C	18978	33			
C	17187	49	C	18979	33			





## NUMERICAL INDEX

PART NO.	PAGE NO.	REF. NO.	PART NO.	PAGE NO.	REF. NO.		
192-	18	51	4	195-	521	5	8
192-	18	51	23	195-	521	15	13
192-	19	11	18	195-	521	43	12
192-	19	15	2	195-	525	5	4
192-	19	15	8	195-	525	59	9
192-	19	19	13	195-	529	55	9
192-	19	25	25	195-	533	59	8
192-	20	15	12	195-	545	9	25
192-	20	15	6	195-	545	11	36
192-	20	15	12	195-	545	55	11
192-	20	25	11	195-	2021	27	10
192-	20	31	10	195-	2021	31	9
192-	20	33	24	195-	2069	31	15
192-	20	45	3	195-	2069	33	15
192-	20	55	23	205-	27	11	30
192-	21	5	5	211-	5	39	10
192-	21	11	8	214-	103	15	4
192-	21	11	15	219-	17	29	20
192-	21	11	24	219-	403	29	4
192-	21	11	32	219-	404	29	6
192-	21	19	7	219-	404	31	19
192-	21	23	20	219-	404	43	2
192-	21	25	13	221-	13	41	75
192-	21	31	14	221-	672	41	52
192-	21	33	6	221-	1412	11	45
192-	21	35	6	223-	20	49	22
192-	21	49	19	321-	1423	53	4
192-	21	51	29	321-	1786	53	5
192-	21	59	8	321-	2110	53	7
192-	23	27	5	321-	2498	53	2
192-	23	29	14	321-	2498	53	1
192-	23	43	2	321-	2502	53	3
192-	23	49	16	321-	3003	53	3
192-	23	55	4	353-	442	21	13
192-	23	57	3	353-	462	21	4
192-	23	59	7				
192-	26	47	35				
192-	116	45	35				
193-	4	49	8				
193-	5	51	9				
193-	29	51	12				
193-	56	19	8				
193-	60	15	10				
193-	70	51	19				
193-	76	23	5				
195-	104	21	17				
195-	104	25	12				
195-	104	33	9				
195-	104	33	18				
195-	104	35	5				
195-	104	37	5				
195-	126	21	18				
195-	513	51	35				
195-	515	11	21				
195-	515	19	10				
195-	520	51	13				

# INGERSOLL

Ingersoll Equipment Co., Inc.