

PARTNER

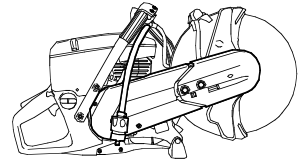

IPL, K750, 2006-04, 544 00 18-04

K750

Reservdelar

Spare parts

Ersatzteile

Pieces de rechange

Piezas de repuesto

Ricambi

***Peças
sobresselente***

544 00 18-04

PARTNER®

No.	Pos.	Description	No.	Pos.	Description
501 27 08-01	CQR	SLEEVE	506 07 09-01	B	WASHER
501 27 13-02	F	GROMMET	506 09 56-06	N	CLAMP
501 48 54-02	J	SPARK PLUG CONN. KIT	506 09 58-24	N	HOSE 800 MM
501 63 48-01	J	SPRING	506 09 75-02	N	HOSE
501 67 32-03	J	PAWL	506 13 95-11	A	WASHER
501 76 83-28	F	HOSE	506 13 96-01	A	SCREW
501 81 99-01	J	SCREW	506 14 32-01	A	CATCH
503 12 79-02	H	STARTER HANDLE	506 22 28-01	F	THROTTLE LOCK
503 16 40-01	F	VALVE	506 25 14-01	H	WASHER
503 20 00-45	A	SCREW	506 25 30-01	H	SPRING
503 20 03-12	CQR	SCREW	506 25 59-32	F	TANK CAP
503 20 72-75	A	SCREW	506 25 81-02	H	STARTER PULLEY
503 21 28-06	FJ	SCREW	506 25 89-01	H	RETURN SPRING
503 21 28-10	HJ	SCREW	506 26 31-01	H	SLEEVE
503 21 45-16	F	SCREW	506 26 41-01	F	FILTER
503 21 53-10	ADGL	SCREW	506 26 41-11	F	FILTER
503 21 53-20	JL	SCREW	506 26 63-02	B	LINING
503 21 53-21	CDGHK	SCREW	506 26 64-01	B	FLANGE
503 21 53-25	DR	SCREW	506 26 65-01	B	FLANGE
503 21 53-40	G	SCREW	506 26 66-04	A	TENSIONER
503 21 53-41	CDQR	SCREW	506 26 68-01	A	SPRING
503 21 53-56	DKL	SCREW	506 27 11-01	F	PENDULUM
503 21 54-20	DFGN	SCREW	506 27 27-10	J	FLYWHEEL
503 21 67-22	H	SCREW	506 27 84-42	K	DECAL
503 22 10-11	J	NUT	506 27 84-61	K	DECAL
503 22 65-04	CFL	NUT	506 27 84-63	K	DECAL
503 23 00-42	J	WASHER	506 28 40-02	B	LABEL
503 23 00-73	C	WASHER	506 28 40-04	B	LABEL
503 23 01-01	J	WASHER	506 28 40-12	B	LABEL
503 23 01-04	A	WASHER	506 28 40-14	B	LABEL
503 23 01-16	A	WASHER	506 28 44-01	A	BOLT
503 23 51-09	J	SPARK PLUG RCJ6Y	506 28 73-01	A	NUT
503 25 21-01	A	BALL BEARING	506 28 84-01	A	FLANGE
503 25 56-01	DEQR	NEEDLE BEARING	506 29 21-01	F	GASKET
503 26 02-04	CQR	SEALING RING	506 29 56-01	N	NIPPLE
503 26 30-21	N	O-RING	506 29 57-02	N	NIPPLE
503 28 32-09	LM	CARBURETOR	506 29 67-02	A	BELT
503 28 90-47	DR	PISTON RING	506 29 83-63	A	SHAFT
503 40 06-09	L	HOSE	506 29 88-01	N	SCREEN
503 47 96-01	M	SCREW	506 31 86-01	J	STOP SWITCH
503 48 00-01	M	PIN FULCRUM	506 32 48-01	B	FLANGE
503 48 11-01	M	PLUG	506 32 87-01	N	Y TUBE
503 48 18-01	M	SCREW	506 33 56-15	H	STARTER ROPE
503 53 56-01	M	PLUG	506 34 05-12	B	GUARD
503 53 57-01	M	STRAINER	506 34 05-14	B	GUARD
503 55 22-01	DR	PLUG	506 34 46-01	B	HANDLE
503 57 76-03	F	HOSE	506 36 42-03	D	MUFFLER
503 57 89-01	F	HOLDER	506 36 68-01	K	COVER
503 61 66-01	M	GASKET	506 36 69-01	K	BASE
503 66 59-01	M	LEVER	506 36 71-01	K	FILTER
503 71 53-01	D	VALVE DECOMPR.	506 36 88-01	D	BRACKET
503 74 43-01	C	SPRING	506 36 91-02	C	PROTECTOR
503 74 44-04	C	CLUTCH	506 36 92-02	H	COVER
503 84 61-01	CQR	BUFFER	506 36 93-02	H	AIR CONDUCTOR
504 35 72-01	F	FUEL FILTER	506 36 96-01	A	PULLEY
505 27 75-16	J	INSULATING CAP	506 36 97-01	L	PIPE
505 30 24-15	C	SUPPORT BUSHING	506 36 98-01	L	PIPE
506 02 87-01	B	WASHER	506 37 03-01	K	JET
506 02 88-30	B	BUSHING	506 37 04-01	K	BELLOW
506 07 08-01	A	SPACER	506 37 05-01	L	FLANGE

No.	Pos.	Description	No.	Pos.	Description
506 37 06-01	L	FLANGE	506 39 60-01	M	DIAPHRAGM PUMP
506 37 10-71	E	CRANKSHAFT	506 39 61-01	M	NOZZLE ASSY CHECK VALVE
506 37 11-01	G	HANDLE	506 39 62-01	M	GASKET METERING
506 37 13-01	F	THROTTLE ROD	506 39 63-01	M	COVER PUMP ASSY
506 37 14-01	F	CHOKE CONTROL	506 39 64-01	M	QUAD RING
506 37 19-01	F	PLATE	506 39 65-01	M	SHAFT, LINKAGE
506 37 20-02	F	THROTTLE TRIGGER	506 39 66-01	M	SCREW
506 37 24-01	DR	PISTON CPL	506 39 67-01	M	SCREW
506 37 55-01	G	SUPPORT	506 39 69-01	M	SCREW
506 37 56-01	G	SUPPORT			
506 37 57-06	C	CRANKCASE	506 39 70-01	M	SCREW
506 37 57-07	Q	W.CRANKCASE	506 39 71-01	M	SHAFT ASSY
506 37 57-08	R	SHORT BLOCK	506 39 72-01	M	SCREW THROTTLE ADJ.
506 37 58-02	D	PLATE	506 39 73-01	M	CHOKE SHAFT
506 37 67-01	CDR	GASKET	506 39 74-01	M	THROTTLE SHAFT
506 37 68-01	L	GASKET	506 39 75-01	M	SPRING
506 37 69-02	CDR	GASKET	506 39 76-01	M	SPRING
506 37 70-02	C	GASKET	506 39 77-01	M	SPRING
506 37 70-03	CQR	GASKET	506 39 78-01	M	VALVE
506 37 72-01	G	BRACKET	506 39 79-01	M	WASHER
506 37 80-01	F	GROMMET	506 39 84-01	K	CYLINDER COVER CPL
506 37 83-03	C	WHEEL	506 39 90-01	M	O-RING
506 37 84-01	J	CABLE	506 39 91-01	M	PLUG
506 37 85-01	J	CABLE	506 40 93-01	A	NUT
506 37 95-01	F	SPRING	506 40 99-01	M	GASKET & DIAPHRAGM KIT
506 37 96-20	B	BUSHING	506 41 00-01	M	REPAIR KIT
506 37 96-25	B	BUSHING	506 41 23-01	CDR	GASKET, MUFFLER
506 38 15-01	F	HEAT SHIELD	537 01 25-01	M	BALL
506 38 26-01	P	TOOL	537 01 26-01	M	SPRING
506 38 53-03	C	GASKET SET	537 17 62-01	M	VALVE
506 38 55-01	L	BRACKET	537 17 70-01	M	THROTTLE FLAP
506 38 56-11	H	STARTER DEVICE CPL	537 17 78-01	M	PLUG
506 38 57-01	H	DECAL	537 20 33-01	EQR	CUP
506 38 58-01	G	HANDLE	537 21 03-07	F	INSULATOR
506 38 59-02	GN	HOSE & VALVE CPL	537 21 03-08	G	VIBRATION ABSORBER
506 38 60-11	N	VALVE CPL	537 38 51-01	M	SCREW
506 38 61-71	D	CYLINDER & PISTON CPL	537 38 52-01	M	CLIP
506 38 62-01	K	COVER	544 00 14-03	D	MUFFLER CPL
506 38 64-01	L	PIPE	544 00 31-01	N	WET CUTTING KIT
506 38 65-11	F	TANK UNIT CPL	544 00 78-01	CQR	BRACKET
506 38 66-01	F	VALVE CPL	544 04 75-02	J	INGITION MODULE
506 38 67-01	F	SUPPORT	544 06 12-01	CFG	SCREW
506 38 71-01	G	STOP HANDLE	544 08 21-01	M	SCREW
506 38 78-34	J	CABLE	544 08 22-01	M	SCREW
506 38 91-02	D	VIBRATION ABSORBER	544 18 16-01	L	AIR FILTER CPL
506 39 30-01	C	WASHER	720 12 40-20	F	PIN
506 39 32-01	L	BRACKET	725 53 29-55	AB	SCREW
506 39 34-01	C	DECAL	725 53 31-55	B	SCREW
506 39 36-01	A	PROTECTOR	737 43 12-00	DR	RETAINING
506 39 37-01	K	DECAL	738 22 02-25	CEQR	BALL BEARING
506 39 38-01	K	DECAL	740 43 13-00	H	O-RING
506 39 42-03	A	HOUSING			
506 39 42-11	A	HOUSING			
506 39 46-01	F	COVER			
506 39 52-01	L	PLATE			
506 39 54-01	M	COLLAR			
506 39 55-01	M	COVER COMPENSATOR			
506 39 56-01	M	COVER METERING			
506 39 57-01	M	DIAPHRAGM ASSY MET.			
506 39 58-01	M	GASKET			

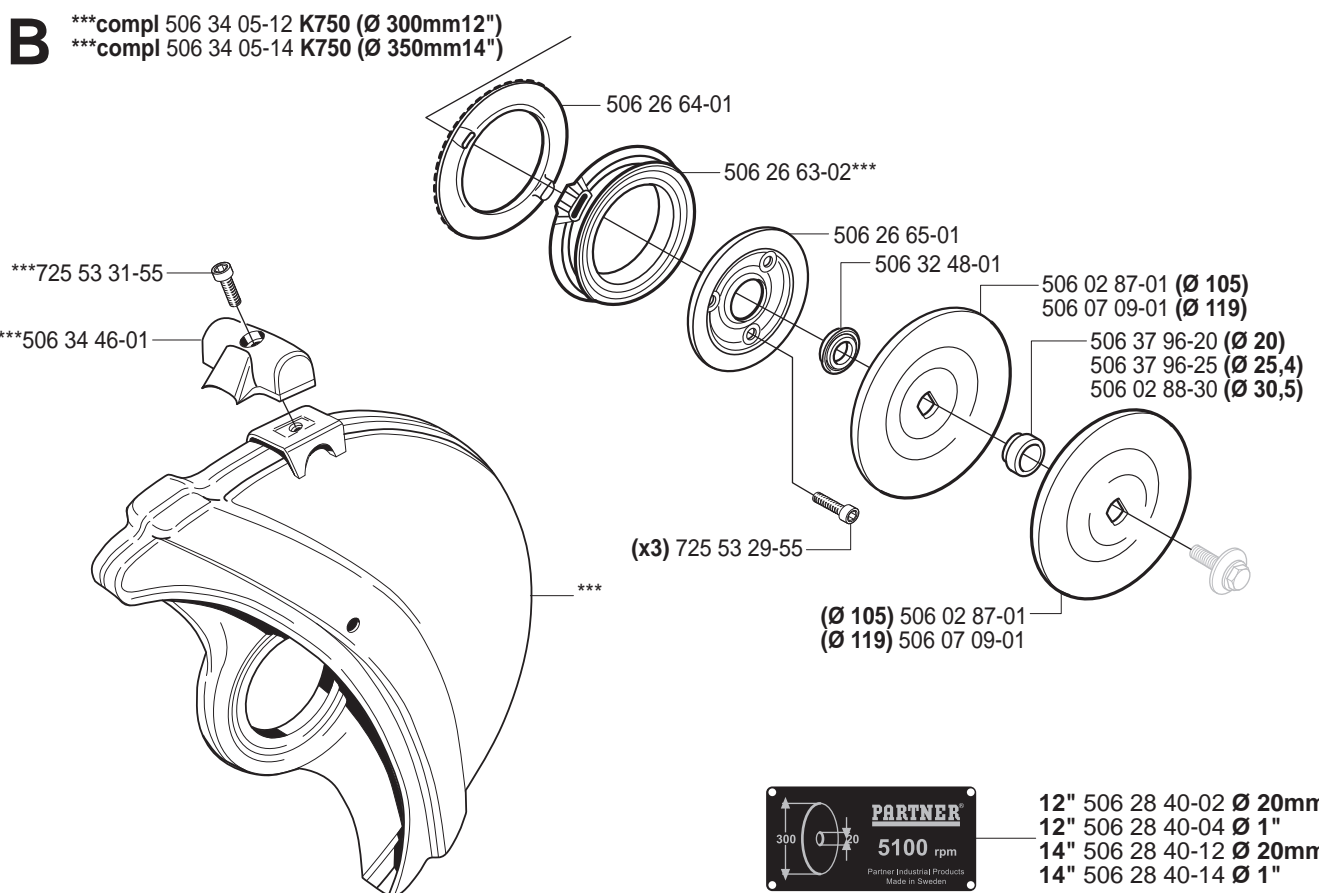
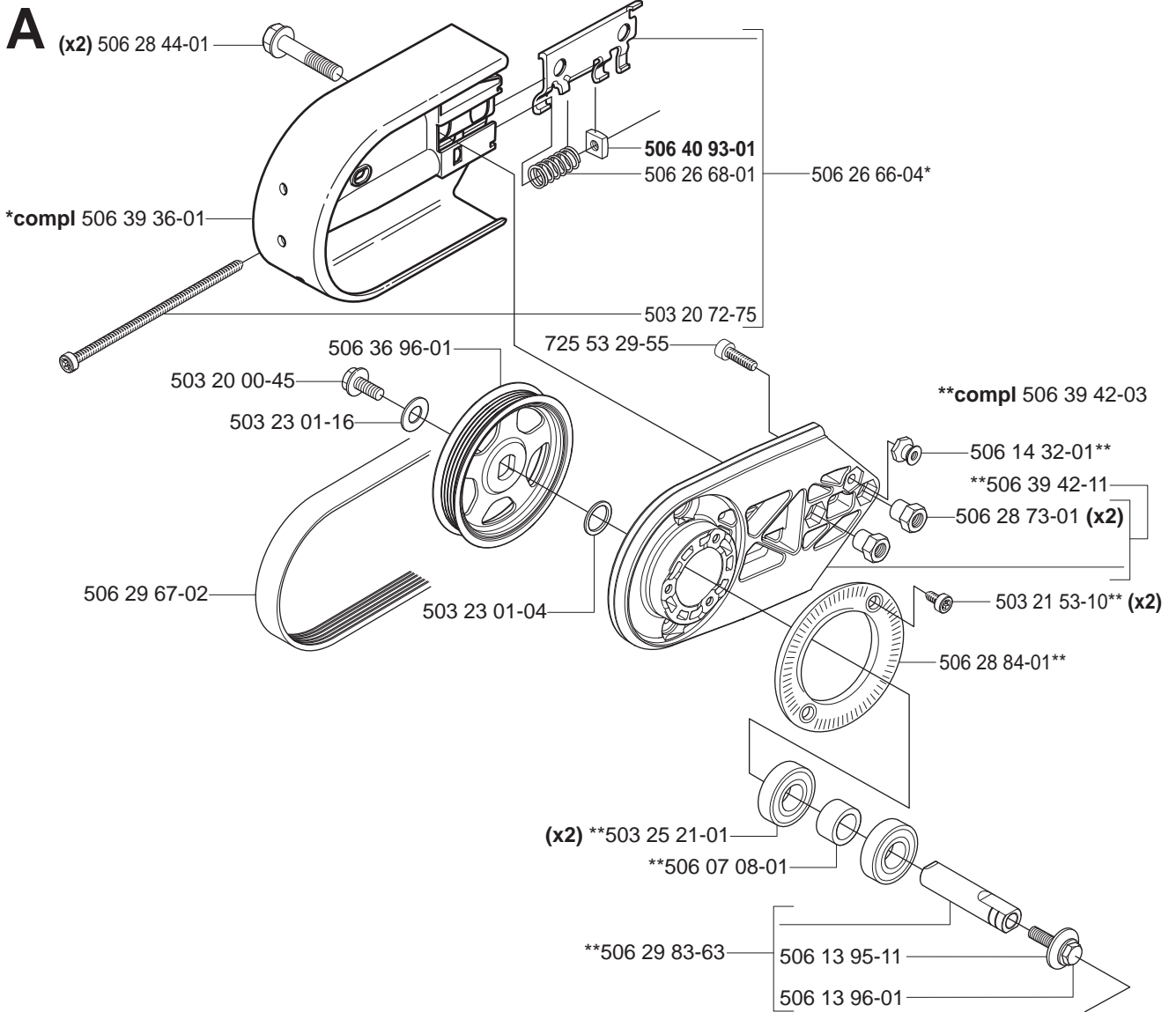

- 12" 506 28 40-02 Ø 20mm
- 12" 506 28 40-04 Ø 1"
- 14" 506 28 40-12 Ø 20mm
- 14" 506 28 40-14 Ø 1"

C**(x2)** 503 21 53-21**PARTNER**

506 39 34-01

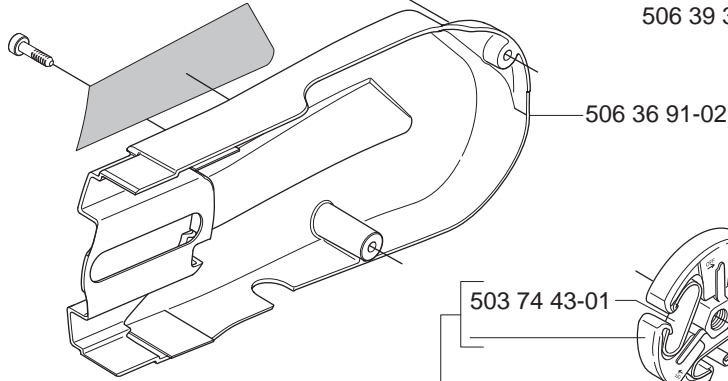

compl 506 37 83-03

503 74 43-01

503 23 00-73

compl 503 74 44-04

505 30 24-15

506 39 30-01

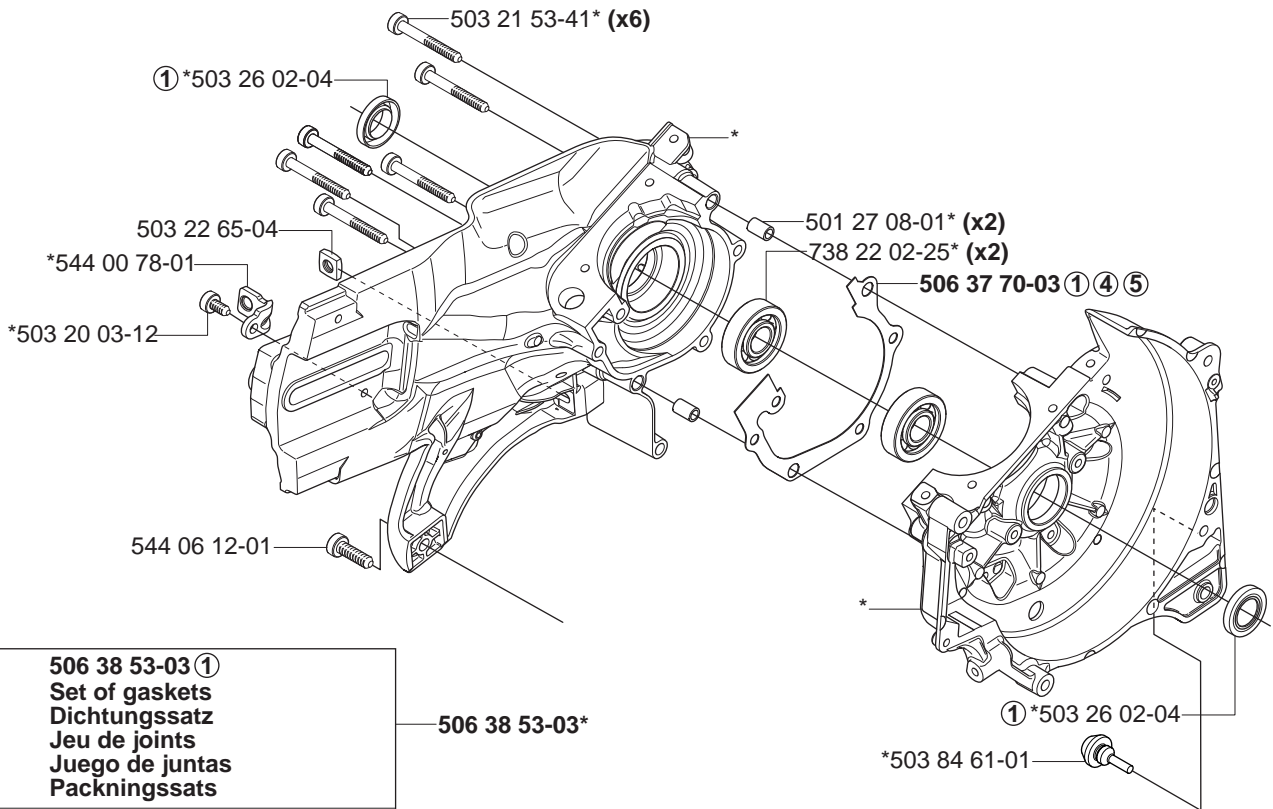
Crankcase:***compl 506 37 57-06 ④ ⑤**

503 21 53-41* (x6)

① *503 26 02-04

503 22 65-04

*544 00 78-01

*503 20 03-12

544 06 12-01

501 27 08-01* (x2)

738 22 02-25* (x2)

506 37 70-03 ① ④ ⑤

① *503 26 02-04

*503 84 61-01

506 38 53-03*

506 38 53-03 ①**Set of gaskets****Dichtungssatz****Jeu de joints****Juego de juntas****Packningssats**

506 41 23-01

506 37 69-02

506 37 70-02

506 37 70-03

506 37 67-01

503 26 02-04 (x2)

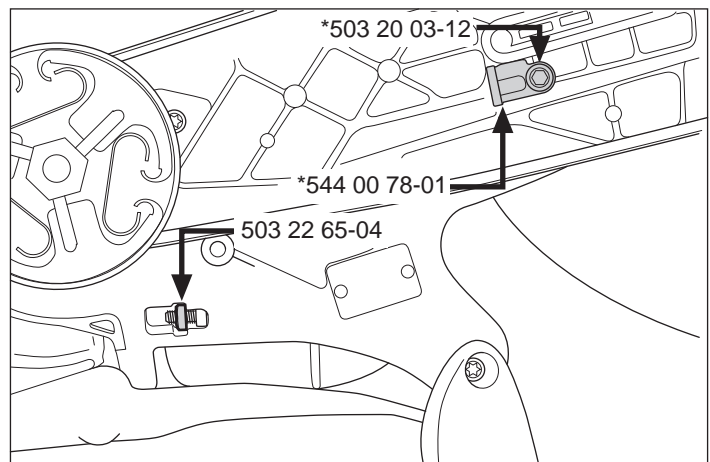

*503 20 03-12

*544 00 78-01

503 22 65-04

D Cylinder & Piston
 *compl 506 38 61-71 ⑤

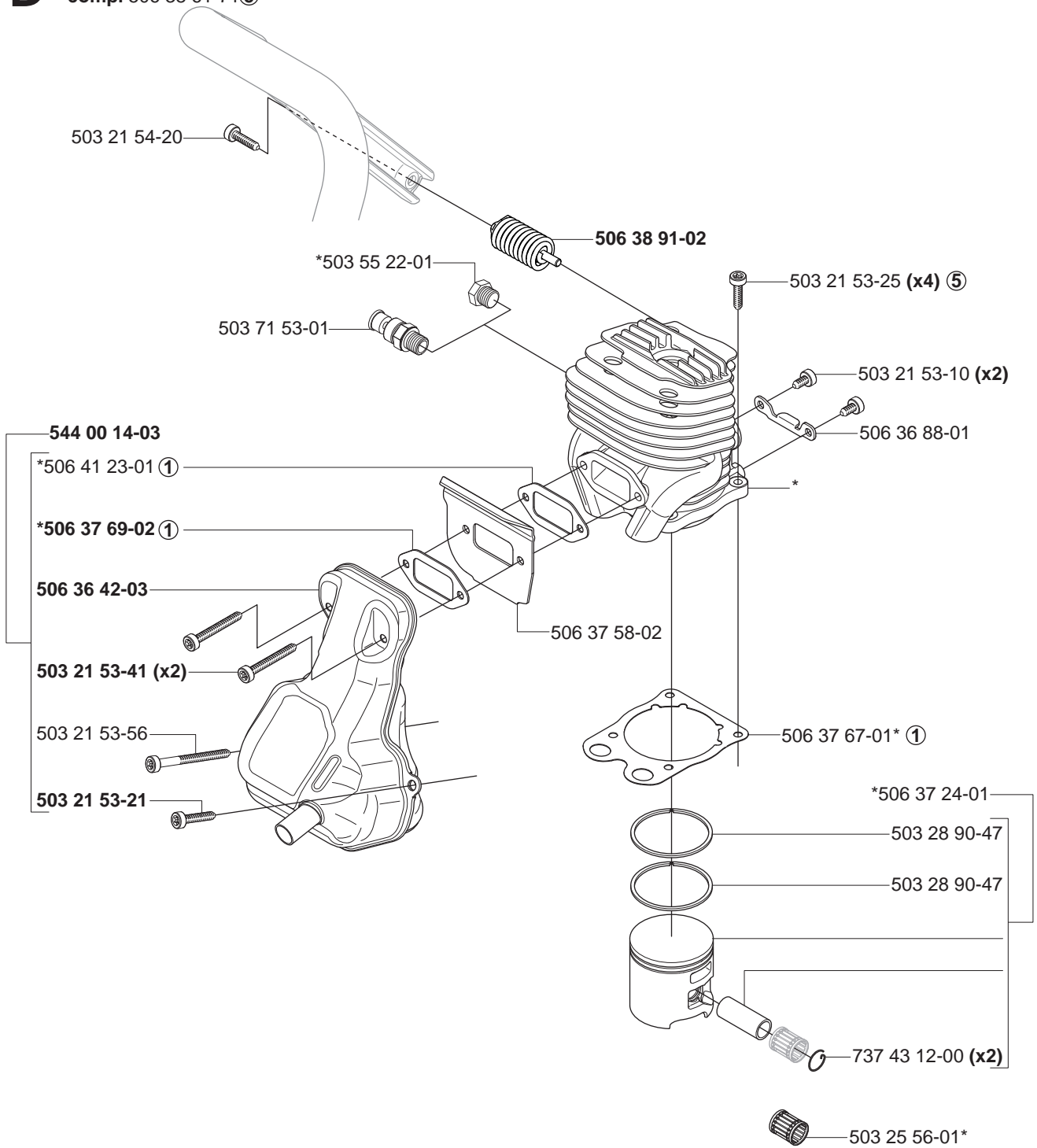

E Crankshaft
 *compl 506 37 10-71 ④ ⑤

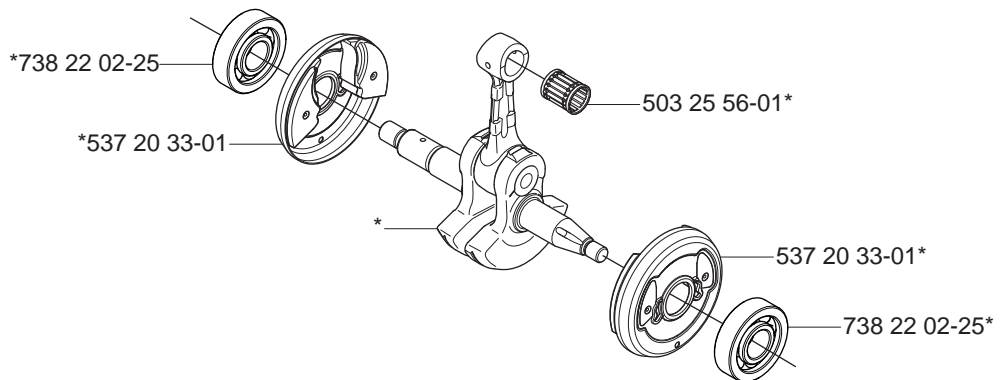

F Tank unit
 *compl 506 38 65-11

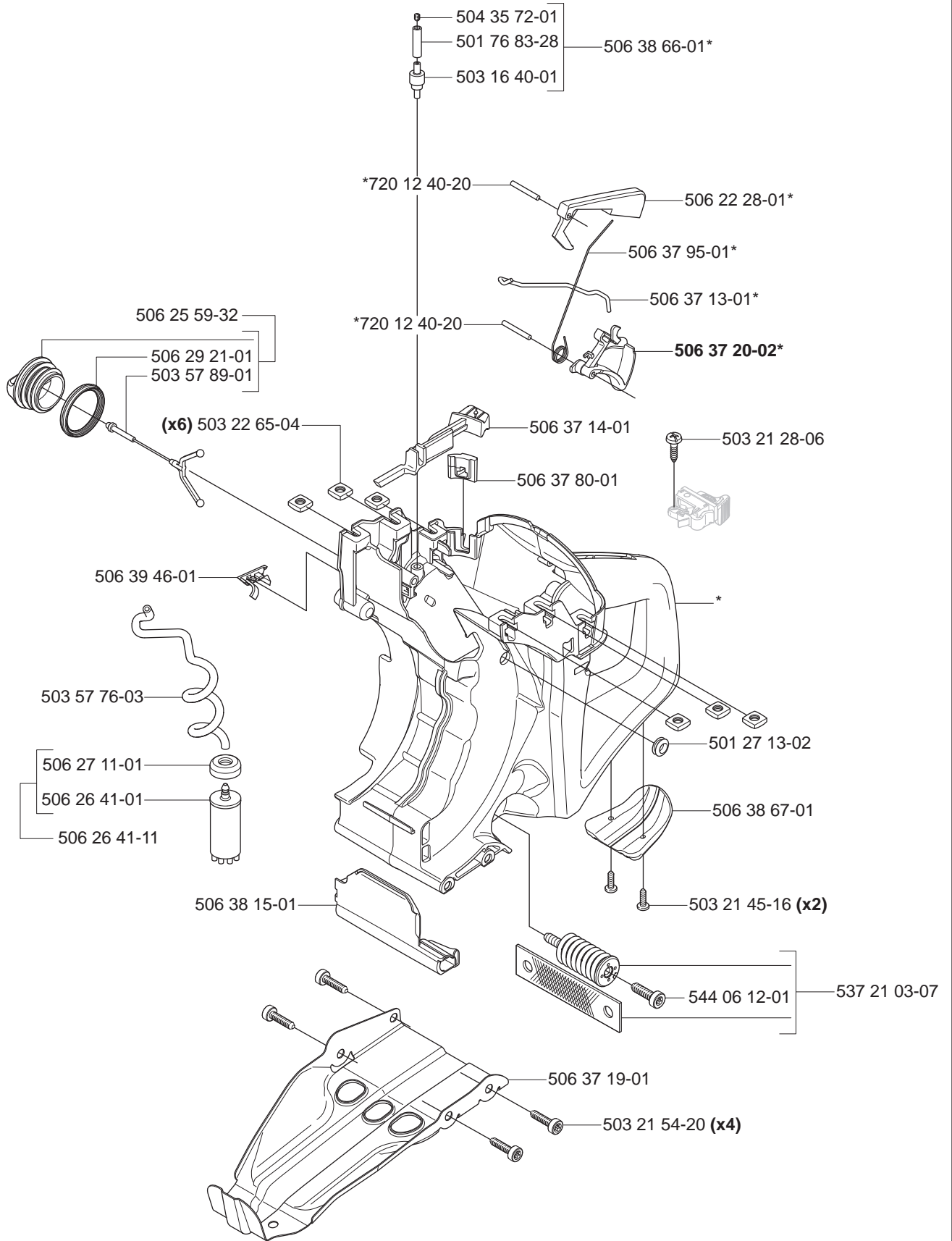

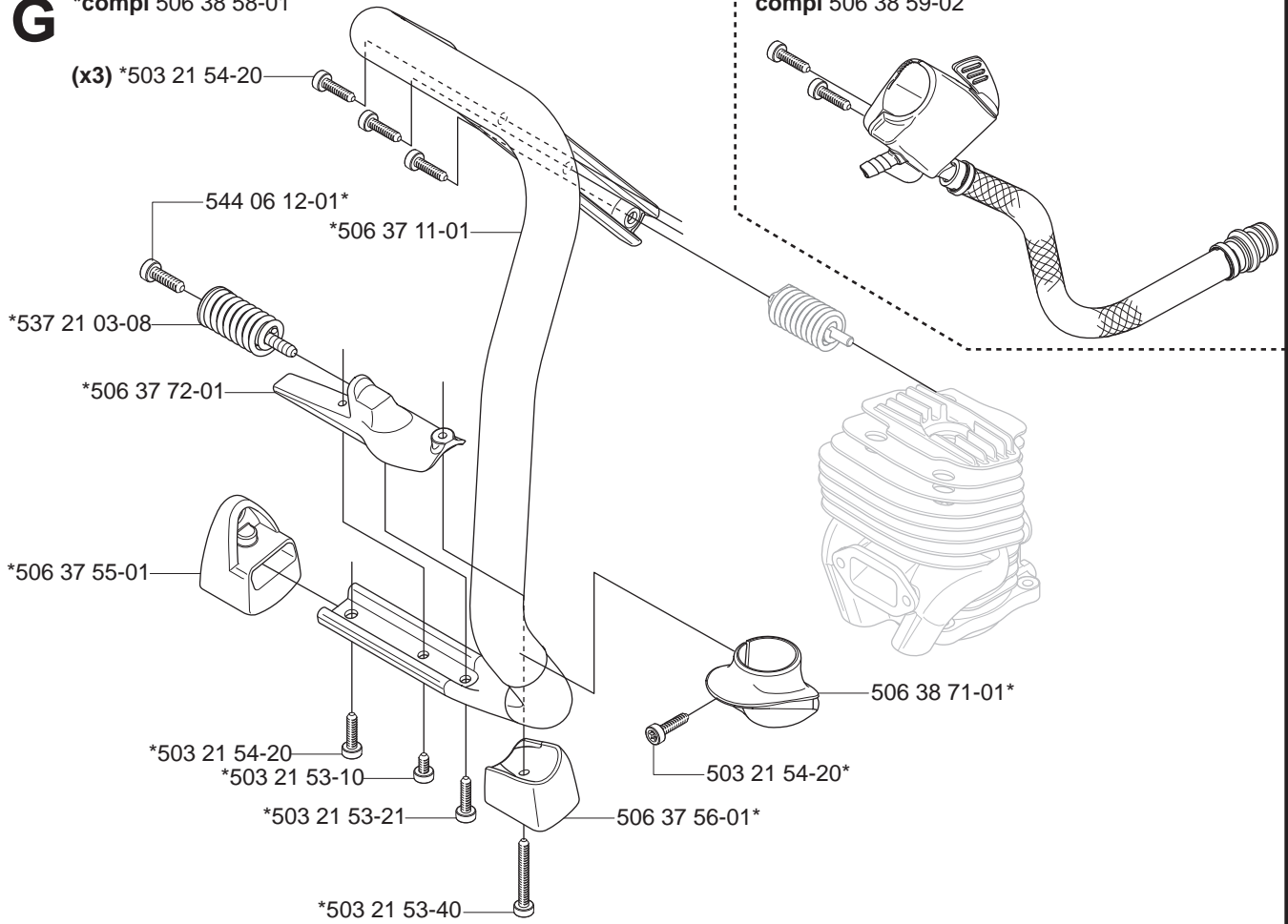
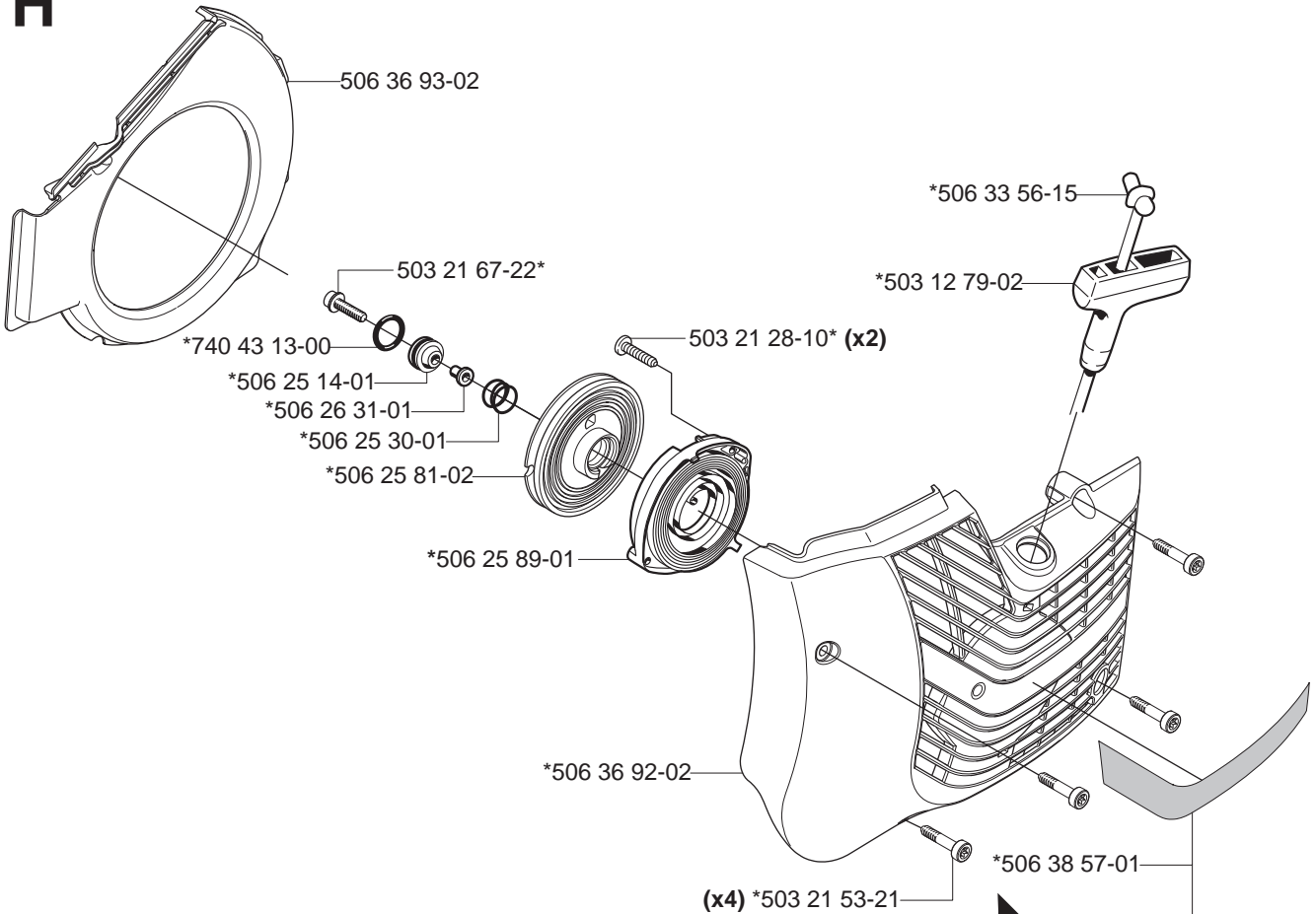
G***compl 506 38 58-01****compl 506 38 59-02****H*****compl 506 38 56-11**

DUAL CHARGE

PARTNER

J

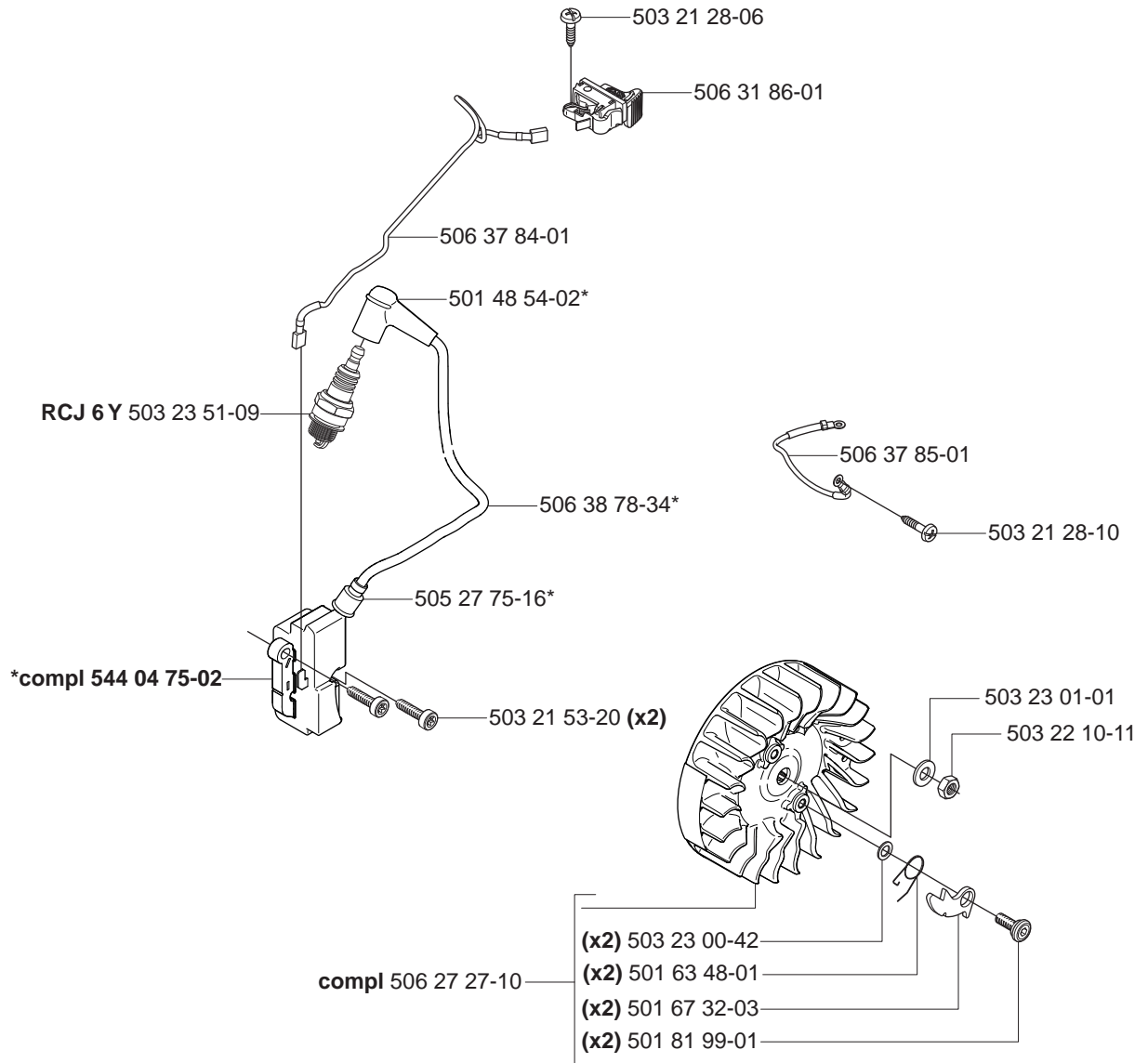

K

(x2) 503 21 53-56

503 21 53-21

506 36 68-01

506 36 71-01

506 36 69-01

(x4) 503 21 53-21

*compl 506 39 84-01

(x3) 503 21 53-21

506 27 84-42
CE

506 27 84-61
EPA USA

506 27 84-63
EPA Canada



506 39 37-01*



506 39 38-01*



506 38 62-01

506 37 04-01

506 37 03-01

L

544 18 16-01

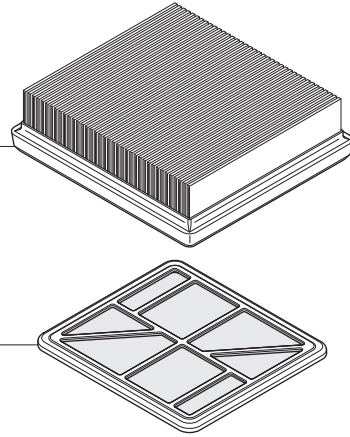

*compl 506 38 55-01

506 38 64-01*

(x2) *503 21 53-10

506 37 06-01

506 36 98-01

503 21 53-20

506 37 05-01

506 36 97-01

503 40 06-09

506 39 52-01

(x2) *503 21 53-56

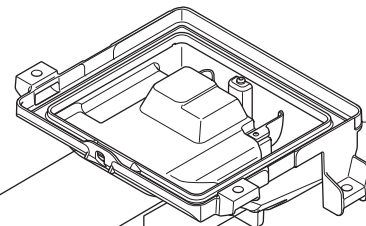

503 22 65-04 (x4)

*506 39 32-01

506 37 68-01*

503 28 32-09* Zama C3-EL29

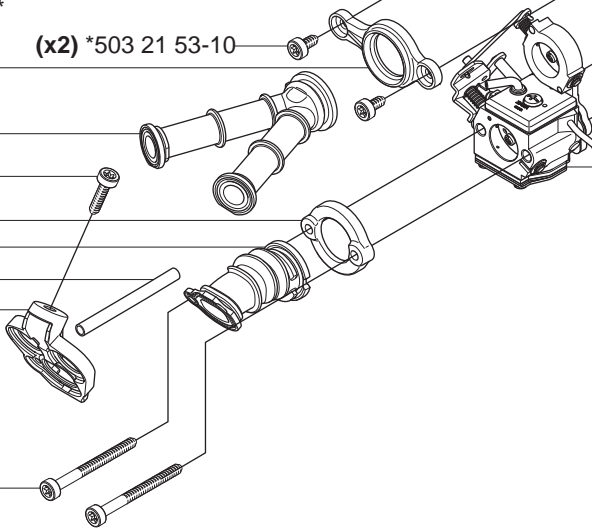

M

*compl 503 28 32-09 ZAMA C3-EL29

ZAMA C3-EL29

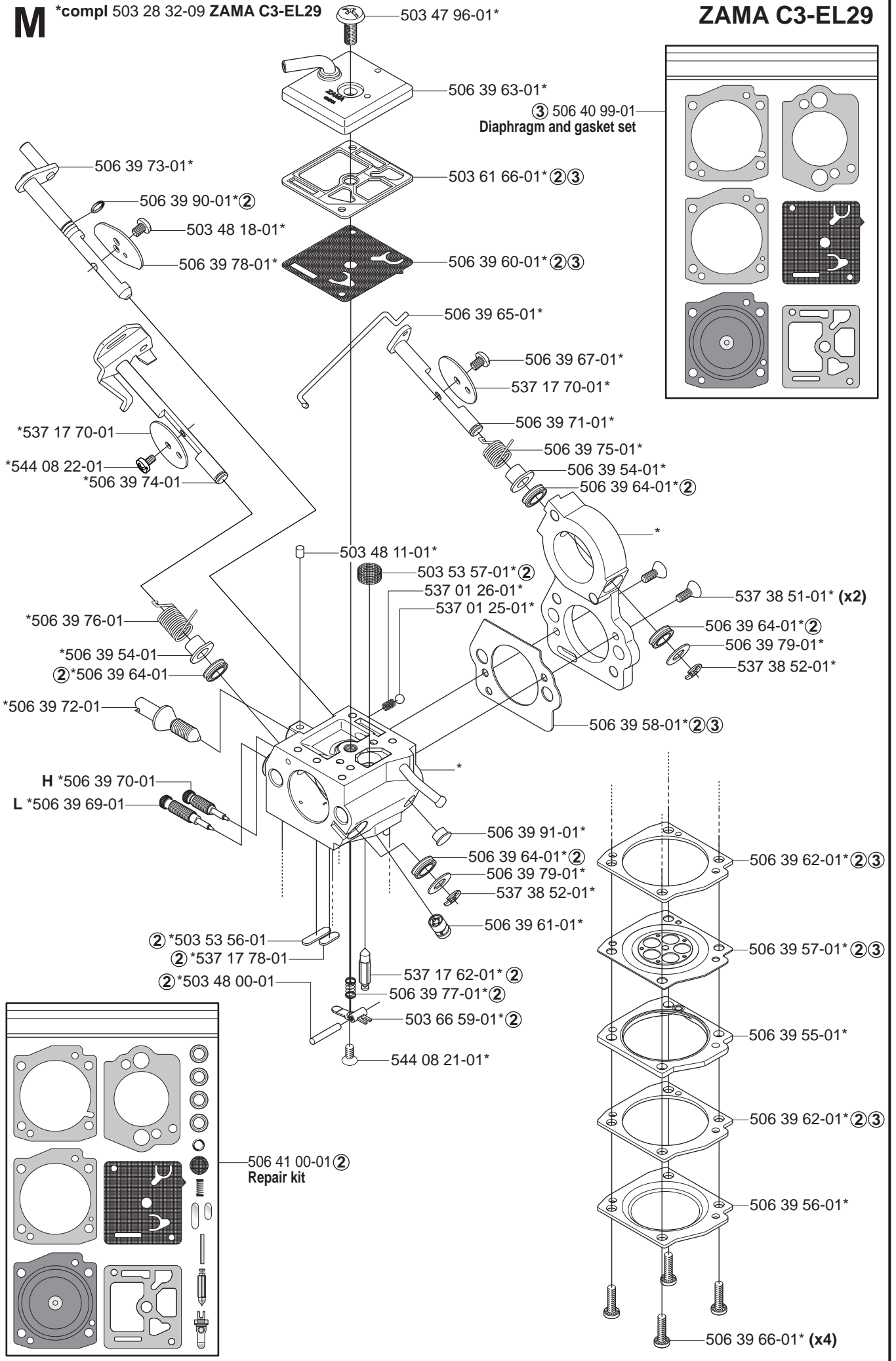

N Wet cutting kit
*compl 544 00 31-01

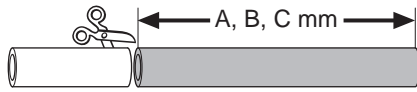
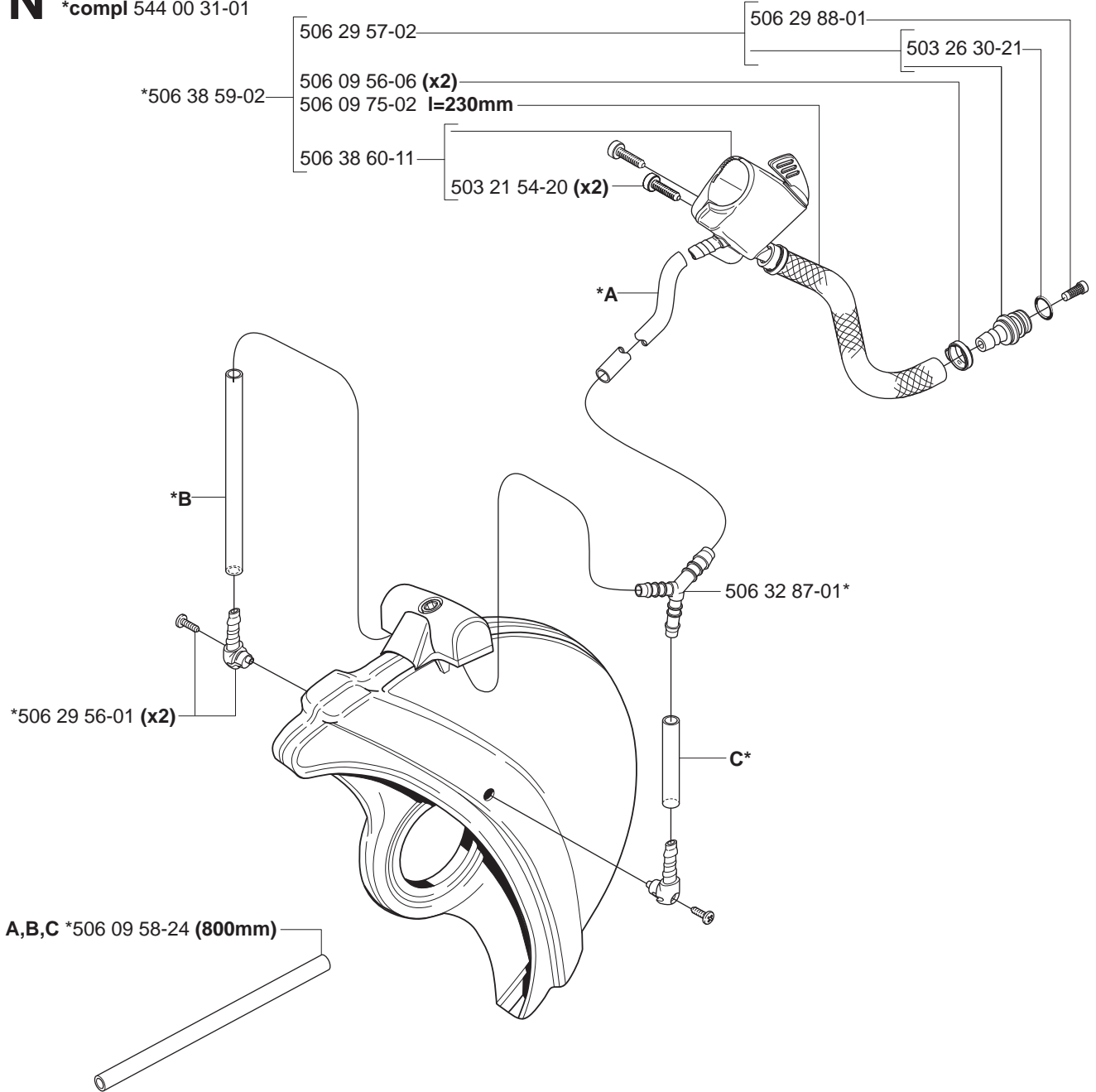

Product	A (mm)	B (mm)	C (mm)
K750 12"	240	240	45
K750 14"	240	280	45

P Accessories
Zubehöre
Accessoires
Accesorios
Tillbehör

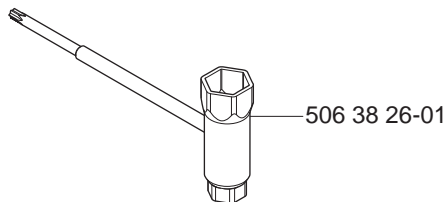

Q Crankcase kit ④
compl 506 37 57-07

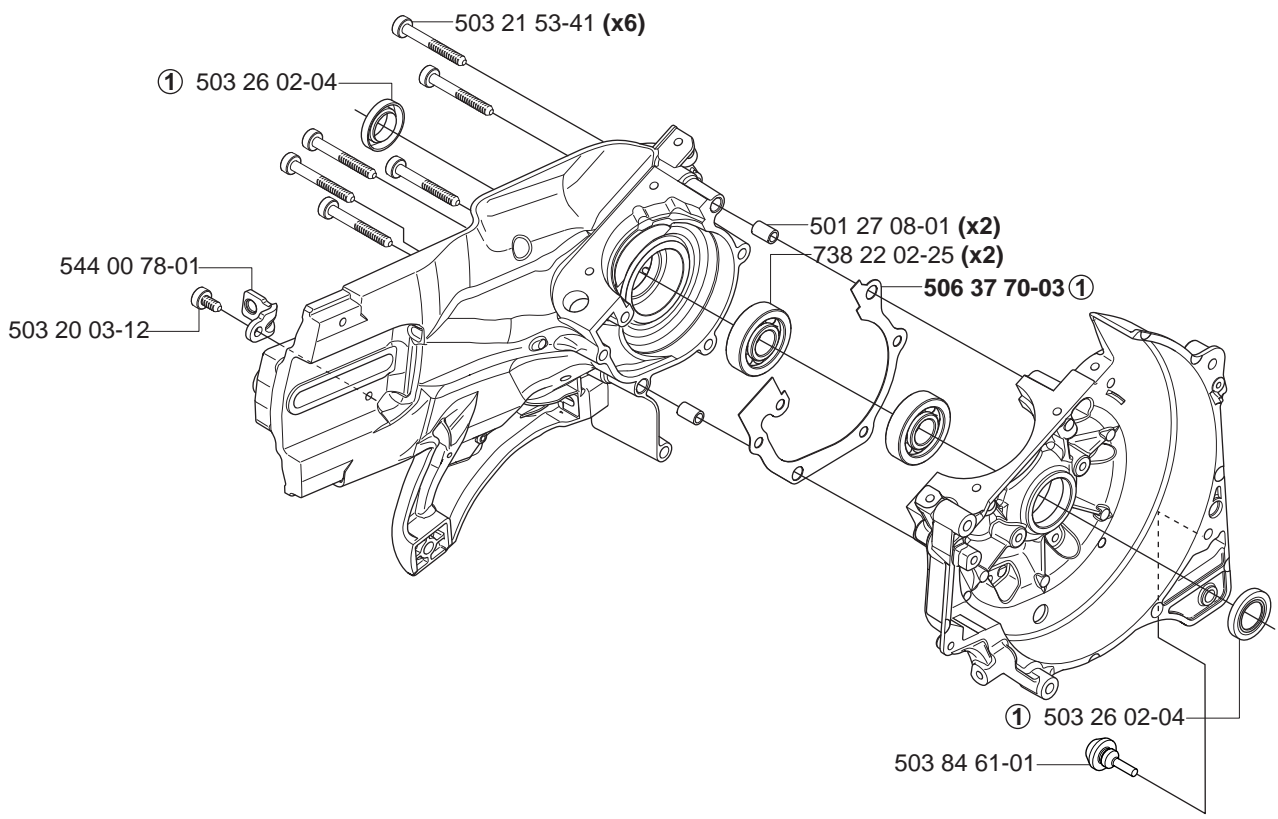
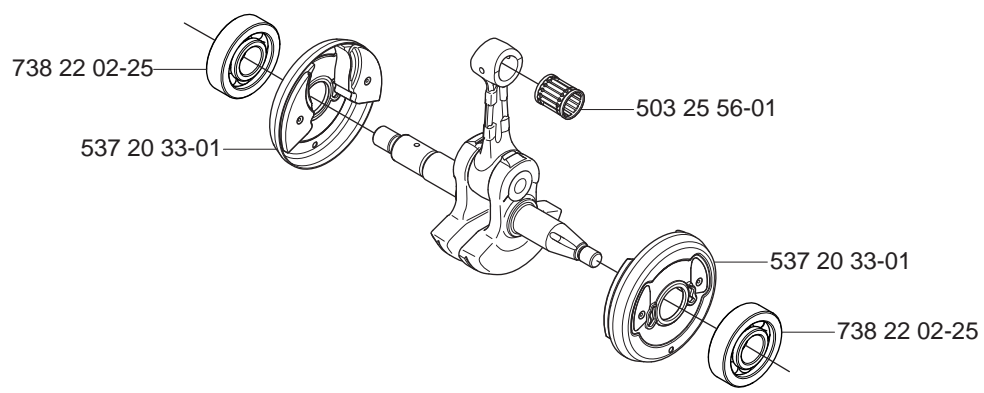

R Crankcase kit ⑤
compl 506 37 57-08

